



**THE DATASHEET OF
LTC3625IDE-1#PBF**



1A High Efficiency 2-Cell Supercapacitor Charger with Automatic Cell Balancing

FEATURES

- High Efficiency Step-Up/Step-Down Charging of Two Series Supercapacitors
- Automatic Cell Balancing Prevents Capacitor Overvoltage During Charging
- Programmable Charging Current Up to 500mA (Single Inductor), 1A (Dual Inductor)
- $V_{IN} = 2.7V$ to $5.5V$
- Selectable 2.4V/2.65V Regulation per Cell (LTC3625)
- Selectable 2V/2.25V Regulation per Cell (LTC3625-1)
- Low No-Load Quiescent Current: $23\mu A$
- $I_{VOUT}, I_{VIN} < 1\mu A$ in Shutdown
- Low Profile 12-lead $3mm \times 4mm$ DFN Package

APPLICATIONS

- Servers, RAID Systems, Mass Storage, High Current Backup Supplies
- Solid State Hard Drives
- Wireless Power Meters
- High Peak Power Boosted Supplies

LT, LT, LTC, LTM, Linear Technology and the Linear logo are registered trademarks and ThinSOT is a trademark of Linear Technology Corporation. All other trademarks are the property of their respective owners.

DESCRIPTION

The LTC[®]3625/LTC3625-1 are programmable supercapacitor chargers designed to charge two supercapacitors in series to a fixed output voltage (4.8V/5.3V or 4V/4.5V selectable) from a 2.7V to 5.5V input supply. Automatic cell balancing prevents overvoltage damage to either supercapacitor while maximizing charge rate. No balancing resistors are required.

High efficiency, high charging current, low quiescent current and low minimum external parts count (one inductor, one bypass capacitor at V_{IN} and one programming resistor) make the LTC3625/LTC3625-1 ideally suited for small form factor backup or high peak power systems.

Charging current/maximum input current level is programmed with an external resistor. When the input supply is removed and/or the EN pin is low, the LTC3625/LTC3625-1 automatically enter a low current state, drawing less than $1\mu A$ from the supercapacitors.

The LTC3625/LTC3625-1 are available in a compact 12-lead $3mm \times 4mm \times 0.75mm$ DFN package.

TYPICAL APPLICATION

1A SCAP Charger

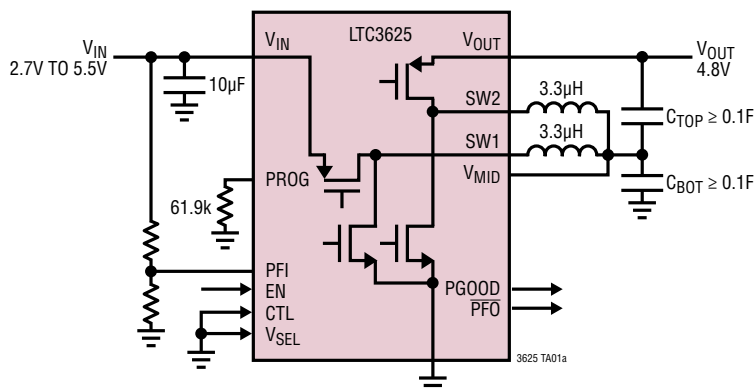

Charging Two 2:1 Mismatched Supercapacitors

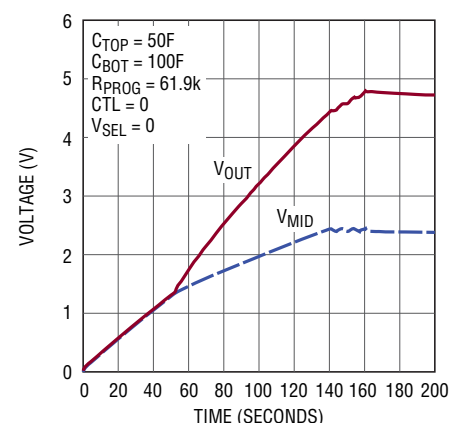

3625 TA01b

LTC3625/LTC3625-1

ABSOLUTE MAXIMUM RATINGS

(Note 1)

V_{IN} , V_{OUT} (Transient) $t < 1\text{ms}$, Duty Cycle $< 1\%$	-0.3V to 7V
V_{IN} , V_{OUT} , V_{MID} , PGOOD, CTL, PROG, PFI, PFO	-0.3V to 6V
EN, V_{SEL}	-0.3V to $V_{IN} + 0.3\text{V}$
V_{OUT} Short-Circuit Duration	Indefinite
I_{PGOOD} , I_{PFO}	50mA
I_{PROG}	1mA
I_{VIN} , I_{SW1} , I_{SW2} , I_{VOUT} (Note 2)	3A
Operating Junction Temperature Range (Notes 3, 4)	-40°C to 125°C
Storage Temperature Range	-65°C to 125°C

PIN CONFIGURATION

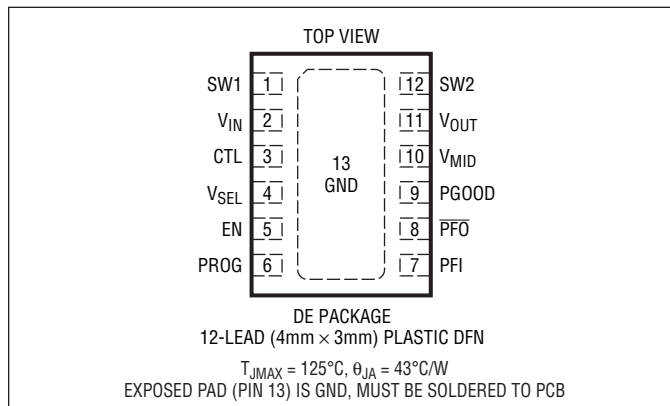

ORDER INFORMATION

LEAD FREE FINISH	TAPE AND REEL	PART MARKING*	PACKAGE DESCRIPTION	TEMPERATURE RANGE
LTC3625EDE#PBF	LTC3625EDE#TRPBF	3625	12-Lead (4mm × 3mm) Plastic DFN	-40°C to 125°C
LTC3625EDE-1#PBF	LTC3625EDE-1#TRPBF	36251	12-Lead (4mm × 3mm) Plastic DFN	-40°C to 125°C
LTC3625IDE#PBF	LTC3625IDE#TRPBF	3625	12-Lead (4mm × 3mm) Plastic DFN	-40°C to 125°C
LTC3625IDE-1#PBF	LTC3625IDE-1#TRPBF	36251	12-Lead (4mm × 3mm) Plastic DFN	-40°C to 125°C

Consult LTC Marketing for parts specified with wider operating temperature ranges. *The temperature grade is identified by a label on the shipping container. Consult LTC Marketing for information on non-standard lead based finish parts.

For more information on lead free part marking, go to: <http://www.linear.com/leadfree/>

For more information on tape and reel specifications, go to: <http://www.linear.com/tapeandreeel/>

ELECTRICAL CHARACTERISTICS

The ● denotes the specifications which apply over the full operating junction temperature range, otherwise specifications are at $T_A = 25^\circ\text{C}$. $V_{IN} = 3.6\text{V}$, $R_{PROG} = 143\text{k}$, unless otherwise specified.

SYMBOL	PARAMETER	CONDITIONS	MIN	TYP	MAX	UNITS
V_{IN}	Input Voltage Range		● $V_{IN(UVLO)}$		5.5	V
$V_{IN(UVLO)}$	Input Undervoltage Lockout (V_{IN} Rising)	$V_{SEL} = V_{IN}$ (LTC3625) $V_{SEL} = 0\text{V}$ (LTC3625) $V_{SEL} = 0\text{V}$ or V_{IN} (LTC3625-1)	● 2.8 ● 2.53 ● 2.53	2.9 2.63 2.63	3.0 2.73 2.73	V V V
	Input UVLO Hysteresis			100		mV
$V_{OUT(SLEEP)}$	Charger Termination Voltage	$V_{SEL} = V_{IN}$ (LTC3625) $V_{SEL} = 0\text{V}$ (LTC3625) $V_{SEL} = V_{IN}$ (LTC3625-1) $V_{SEL} = 0\text{V}$ (LTC3625-1)	● 5.2 ● 4.7 ● 4.4 ● 3.9	5.3 4.8 4.5 4.0	5.4 4.9 4.6 4.1	V V V V
	Recharge Hysteresis	Below $V_{OUT(SLEEP)}$		135		mV
V_{TOP} , V_{BOT}	Maximum Voltage Across Either of the Supercapacitors After Charging	$V_{SEL} = V_{IN}$, $V_{OUT} = 5.3\text{V}$ (LTC3625) $V_{SEL} = 0\text{V}$, $V_{OUT} = 4.8\text{V}$ (LTC3625) $V_{SEL} = V_{IN}$, $V_{OUT} = 4.5\text{V}$ (LTC3625-1) $V_{SEL} = 0\text{V}$, $V_{OUT} = 4\text{V}$ (LTC3625-1)	● ● ● ●	2.7 2.45 2.3 2.05	2.75 2.5 2.35 2.1	V V V V
	Maximum Supercapacitor Offset After Charging	CTL = 0V CTL = V_{IN}		100 50	180 120	mV mV

3625f

ELECTRICAL CHARACTERISTICS

The ● denotes the specifications which apply over the full operating junction temperature range, otherwise specifications are at $T_A = 25^\circ\text{C}$. $V_{IN} = 3.6\text{V}$, $R_{PROG} = 143\text{k}$, unless otherwise specified.

SYMBOL	PARAMETER	CONDITIONS	MIN	TYP	MAX	UNITS
I_{VIN}	Input Operating Current, $I_{SW1} = I_{SW2} = 0\mu\text{A}$, No Switching	CTL = V_{IN} , $V_{MID} = 1.5\text{V}$, $V_{OUT} = 2.5\text{V}$ (Boost Only)		135	200	μA
		CTL = V_{IN} , $V_{MID} = 1.5\text{V}$, $V_{OUT} = 3.5\text{V}$ (Buck Only)		275	400	μA
		CTL = 0, $V_{MID} = 1.5\text{V}$, $V_{OUT} = 2.5\text{V}$ (Buck and Boost)		365	530	μA
I_{VIN}	Input Sleep Current	$V_{IN} = 5.5\text{V}$, $V_{OUT} = 5.4\text{V}$		23	35	μA
		$V_{IN} = 3.6\text{V}$, $V_{OUT} = 5.4\text{V}$		8	15	μA
I_{VIN}	Input SD Current	$V_{OUT} = 0\text{V}$		0	1	μA
I_{VOUT}	V_{OUT} SD Current	$V_{OUT} = 5.4\text{V}$		0	1	μA
	V_{OUT} Sleep Current	$V_{OUT} = 5.4\text{V}$, $V_{IN} = 3.6\text{V}$, $EN = V_{IN}$ $V_{OUT} = 5.4\text{V}$, $V_{IN} = 5.5\text{V}$, $EN = V_{IN}$		17 1	25 2.5	μA μA
V_{PROG}	PROG Servo Voltage	$V_{OUT} = 3.5\text{V}$, $V_{MID} = 1.5\text{V}$	● 1.17	1.2	1.23	V
h_{PROG}	Ratio of Measured I_{PROG} Current to I_{BUCK} Programmed Current			118,000		
I_{BUCK}	Programmed Buck Charge Current	$R_{PROG} = 143\text{k}$ (Note 5)	0.88	0.99	1.10	A
		$R_{PROG} = 71.5\text{k}$ (Note 5)	1.76	1.98	2.20	A
I_{MAX}	Maximum Programmed Charge Current	$R_{PROG} = 0\Omega$ (Fault Condition) (Note 5)	1.98	2.65	3.31	A
$V_{MID(GOOD)}$	V_{MID} Voltage Where the Boost Regulator is Enabled			1.35		V
	$V_{MID(GOOD)}$ Hysteresis			150		mV
$V_{TRICKLE}$	V_{OUT} Voltage Above Which Boost Regulator Will Exit Trickle Charge Mode and Enter Normal Charge Mode	V_{OUT} Rising		V_{MID}		V
	$V_{TRICKLE}$ Falling Hysteresis			50		mV
$I_{PEAK(BUCK)}$	Buck Charge Current Peak			$1.1 \cdot I_{BUCK}$		A
$I_{VALLEY(BUCK)}$	Buck Charge Current Valley			$0.9 \cdot I_{BUCK}$		A
$I_{PEAK(BOOST)}$	Boost Charge Current Peak	$V_{OUT} = 3\text{V}$, $V_{MID} = 2\text{V}$ (Note 5)	1.59	2.12	2.65	A
		$V_{OUT} = 1\text{V}$, $V_{MID} = 2\text{V}$ (Note 5)		200		mA
$I_{VALLEY(BOOST)}$	Boost Charge Current Valley	$V_{OUT} = 3\text{V}$, $V_{MID} = 2\text{V}$	1.41	1.88	2.35	A
		$V_{OUT} = 1\text{V}$, $V_{MID} = 2\text{V}$		0		mA
$I_{VALLEY(BOOST)}$	Maximum Boost Valley Time	$V_{OUT} = 1\text{V}$, $V_{MID} = 2\text{V}$		6.5		μs
R_{PMOS}	PMOS On-Resistance			120		$\text{m}\Omega$
R_{NMOS}	NMOS On-Resistance			100		$\text{m}\Omega$
I_{LEAK}	SW Pin Leakage Current for SW1, SW2	$EN = 0\text{V}$			1	μA
V_{PFI}	PFI Falling Threshold		● 1.17	1.2	1.23	V
	PFI Hysteresis			15		mV
I_{PFI}	Pin Leakage Current for PFI Pin			0	30	nA
Logic (EN, CTL, V_{SEL}, PGOOD, PFO)						
V_{IL}	Input Low Logic Voltage	EN, CTL, V_{SEL} Pins	●		0.4	V
V_{IH}	Input High Logic Voltage	EN, CTL, V_{SEL} Pins	●	1.2		V
I_{IL} , I_{IH}	Input Low, High Current for CTL	CTL			1	μA
R_{PD}	EN Pin Pull-Down Resistance			4.5		$\text{M}\Omega$
	V_{SEL} Pin Pull-Down Resistance	$EN = V_{IN}$		4.5		$\text{M}\Omega$
V_{OL}	Output Low Logic Voltage	PGOOD, $\overline{\text{PFO}}$ Pins; Sinking 5mA	●	70	200	mV
I_{OH}	Logic High Leakage Current	PGOOD, $\overline{\text{PFO}}$ Pins; Pin Voltage = 5V			1	μA
	PGOOD Rising Threshold	V_{OUT} as a Percentage of Final Target	90	92.5	95	%
	PGOOD Hysteresis	ΔV_{OUT} as a Percentage of Final Target		3		%

3625f

LTC3625/LTC3625-1

ELECTRICAL CHARACTERISTICS

Note 1: Stresses beyond those listed under Absolute Maximum Ratings may cause permanent damage to the device. Exposure to any Absolute Maximum Rating condition for extended periods may affect device reliability and lifetime.

Note 2: The LTC3625/LTC3625-1 internal switches are guaranteed to survive up to 3A of peak current. Internal current limits will restrict peak current to lower levels.

Note 3: The LTC3625/LTC3625-1 are tested under pulsed load conditions such that $T_J \approx T_A$. The LTC3625E/LTC3625E-1 are guaranteed to meet specifications from 0°C to 85°C junction temperature. Specifications over the -40°C to 125°C operating junction temperature range are assured by design, characterization and correlation with statistical process controls. The LTC3625I/LTC3625I-1 are guaranteed over the -40°C to 125°C operating junction temperature range.

The junction temperature (T_J in °C) is calculated from the ambient temperature (T_A in °C) and power dissipation (P_D in Watts) according to the formula:

$$T_J = T_A + (P_D \cdot \theta_{JA})$$

where θ_{JA} (in °C/W) is the package thermal impedance.

Note 4: This IC includes overtemperature protection that is intended to protect the device during momentary overload conditions. The maximum rated junction temperature will be exceeded when this protection is active. Continuous operation above the specified maximum operating junction temperature may impair device reliability or permanently damage the device.

Note 5: Measurements are tested with CTL = 0V.

TYPICAL PERFORMANCE CHARACTERISTICS

$T_A = 25^\circ\text{C}$, $L_1 = 3.3\mu\text{H}$, $L_2 = 3.3\mu\text{H}$, $C_{IN} = 10\mu\text{F}$, $C_{TOP} = C_{BOT}$, LTC3625 unless otherwise specified.

Charge Termination Error vs Temperature

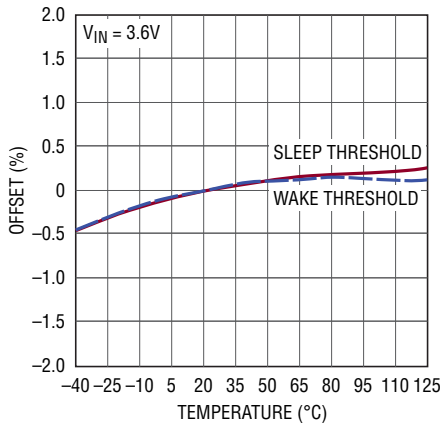

3625 G13

Input and Output Sleep Currents vs Temperature

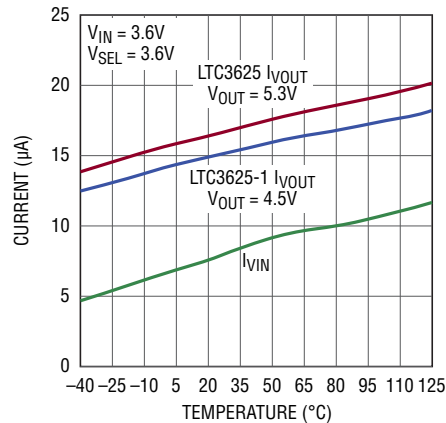

3625 G14

Sleep Current vs V_{IN}

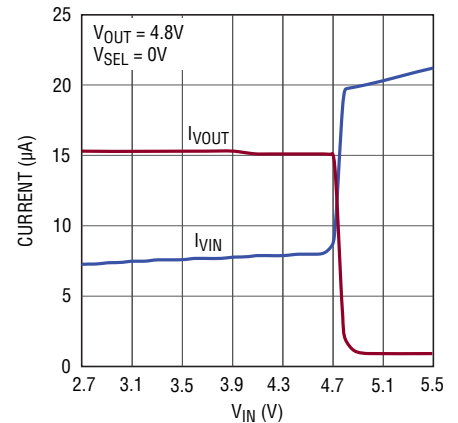

3625 G01

PROG Voltage and PFI Falling Threshold vs Temperature

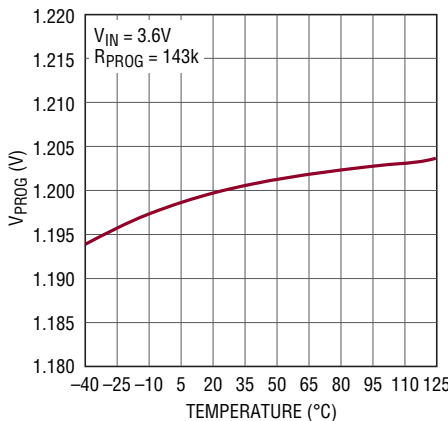

3625 G02

Buck Current Limits vs Temperature

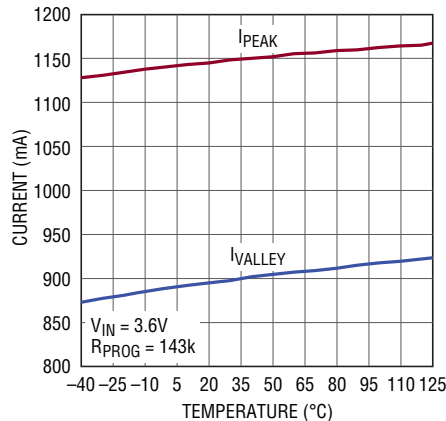

3625 G03

Buck Output Current vs R_{PROG}

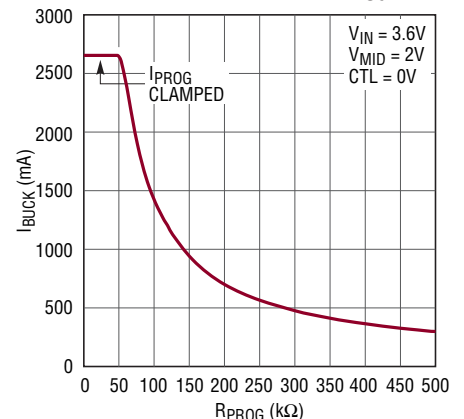

3625 G04
3625f

TYPICAL PERFORMANCE CHARACTERISTICS

$T_A = 25^\circ\text{C}$, $L_1 = 3.3\mu\text{H}$, $L_2 = 3.3\mu\text{H}$, $C_{IN} = 10\mu\text{F}$, $C_{TOP} = C_{BOT}$, LTC3625 unless otherwise specified.

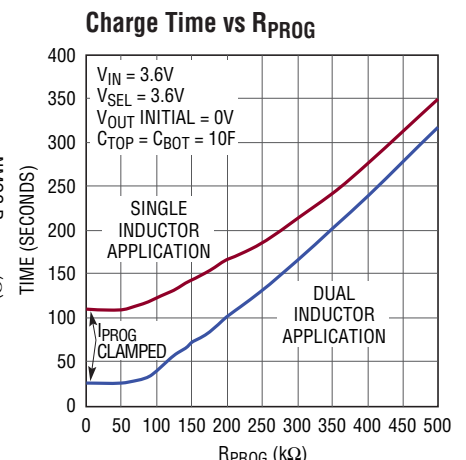
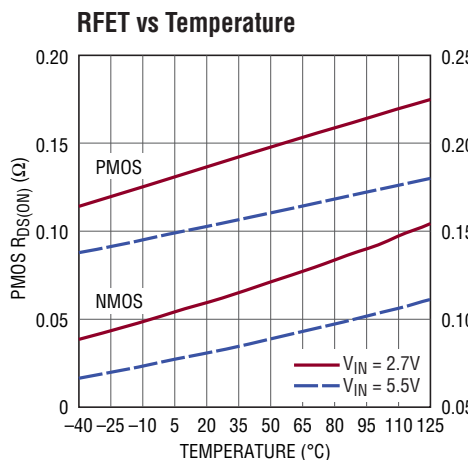
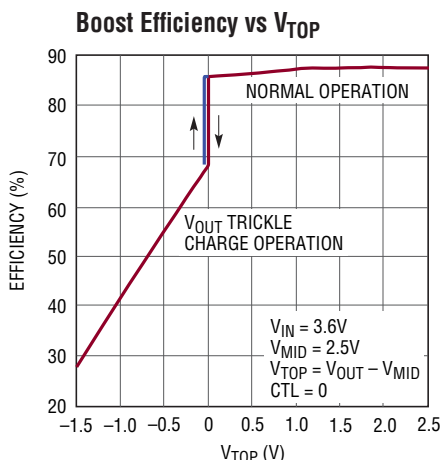
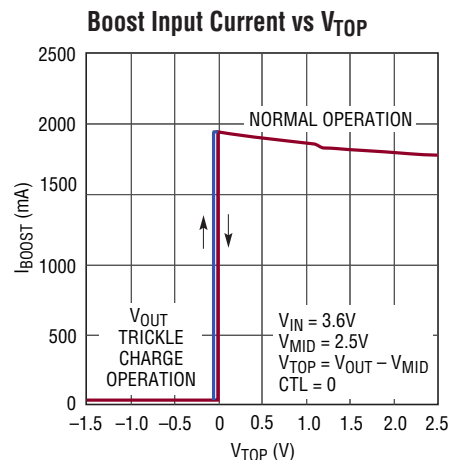
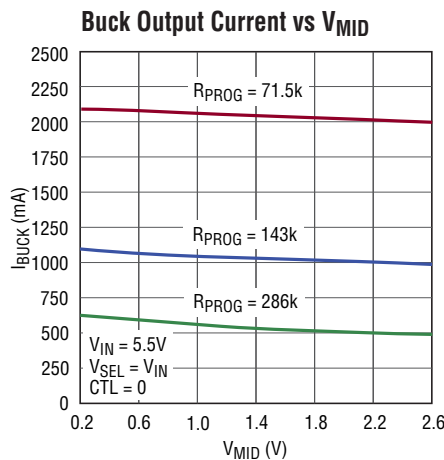
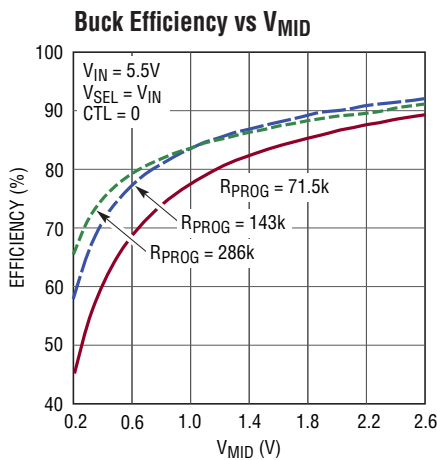
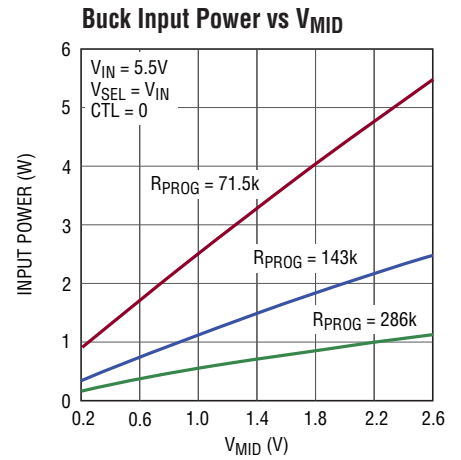
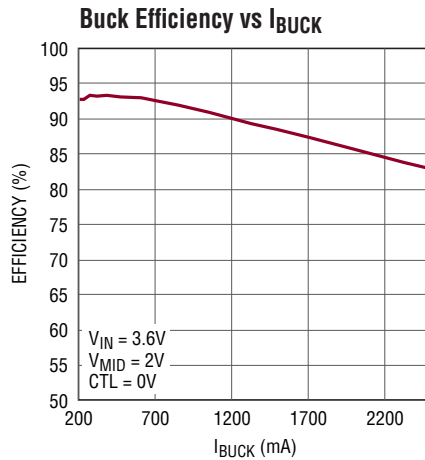
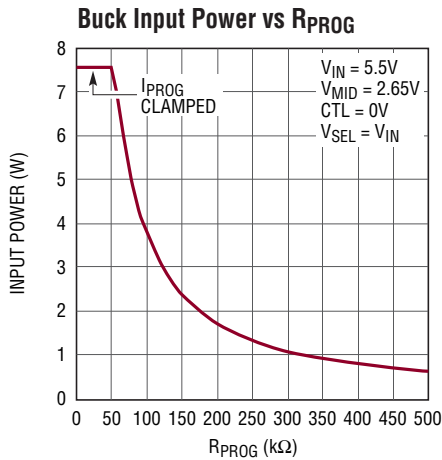

TYPICAL PERFORMANCE CHARACTERISTICS

$T_A = 25^\circ\text{C}$, $L_1 = 3.3\mu\text{H}$, $L_2 = 3.3\mu\text{H}$, $C_{IN} = 10\mu\text{F}$, $C_{TOP} = C_{BOT}$, LTC3625 unless otherwise specified.

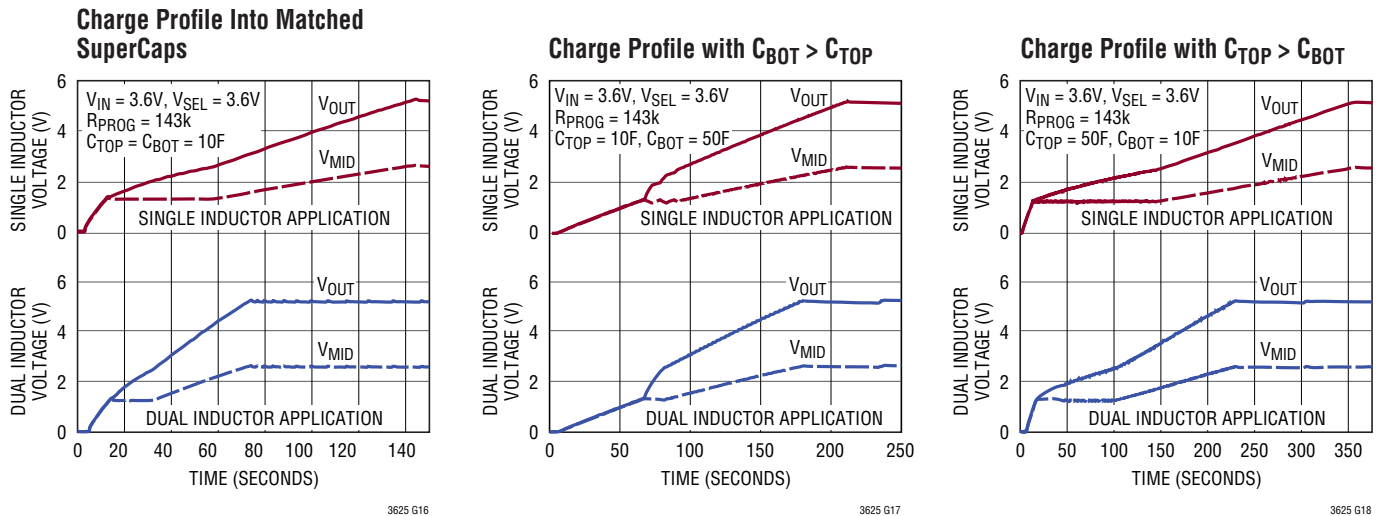

PIN FUNCTIONS

SW1 (Pin 1): Switch Pin for the Buck Regulator. External inductor connects between SW1 pin and V_{MID} .

V_{IN} (Pin 2): Input Voltage Pin. Bypass to GND with a $10\mu\text{F}$ or larger ceramic capacitor.

CTL (Pin 3): Logic Input. CTL sets the charge mode of the LTC3625/LTC3625-1. A logic high at CTL programs the part to operate with a single inductor; a logic low programs the part to operate with two inductors. In the 2-inductor application the capacitor stack will charge approximately twice as quickly. CTL is a high impedance input and must be tied to either V_{IN} or GND. Do not float.

V_{SEL} (Pin 4): Logic Input. V_{SEL} selects the output voltage of the LTC3625/LTC3625-1. A logic low at V_{SEL} sets the per-cell maximum voltage to 2.45V/2.05V ($V_{OUT} = 4.8\text{V}/4.0\text{V}$); a logic high sets the per-cell maximum voltage to 2.70V/2.30V ($V_{OUT} = 5.3\text{V}/4.5\text{V}$). When the part is enabled, V_{SEL} has a $4.5\text{M}\Omega$ internal pull-down resistor; if EN is low, then V_{SEL} is a high impedance input pin.

EN (Pin 5): Logic Input. Enables the LTC3625/LTC3625-1. Active high. Has a $4.5\text{M}\Omega$ internal pull-down resistor.

PROG (Pin 6): Charge Current Program Pin. Connecting a resistor from PROG to ground programs the buck output current. This pin serves to 1.2V.

PFI (Pin 7): Input to the Power Fail Comparator. This pin connects to an external resistor divider between V_{IN} and GND. If this functionality is not desired, PFI should be tied to V_{IN} .

$\overline{\text{PFO}}$ (Pin 8): Open-Drain Output of the Power-Fail Comparator. The part pulls this pin low if V_{IN} is less than a value programmed by an external divider. This pin is active low in shutdown mode. If this functionality is not desired $\overline{\text{PFO}}$ should be left unconnected.

PGOOD (Pin 9): Logic Output. This is an open-drain output which indicates that V_{OUT} has settled to its final value. Upon start-up, this pin remains low until the output voltage, V_{OUT} , is within 92.5% (typical) of its final value. Once V_{OUT} is valid, PGOOD becomes high impedance. If V_{OUT} falls to 89.5% (typical) of its correct regulation level, PGOOD is pulled low. PGOOD may be pulled up through an external resistor to an appropriate reference level. This pin is active low in shutdown mode.

PIN FUNCTIONS

V_{MID} (Pin 10): Midpoint of Two Series Supercapacitors. The pin voltage is monitored and used, along with V_{OUT}, to enable or shut down the buck and boost converters during charging to achieve voltage balancing of the top and bottom supercapacitors.

V_{OUT} (Pin 11): Output Voltage Pin. Connect V_{OUT} to the positive terminal of the top supercapacitor. The pin voltage is monitored and used, along with V_{MID}, to enable or shut down the buck and boost converters during charging to achieve voltage balancing of the top and bottom supercapacitors.

SW2 (Pin 12): Switch Pin for the Boost Regulator. External inductor connects between the SW2 pin and V_{MID}. If CTL is logic high, then SW2 must be connected to SW1.

GND (Exposed Pad Pin 13): Ground. The exposed pad must be connected to a continuous ground plane on the printed circuit board directly under the LTC3625/LTC3625-1 for electrical contact and to achieve rated thermal performance.

BLOCK DIAGRAM

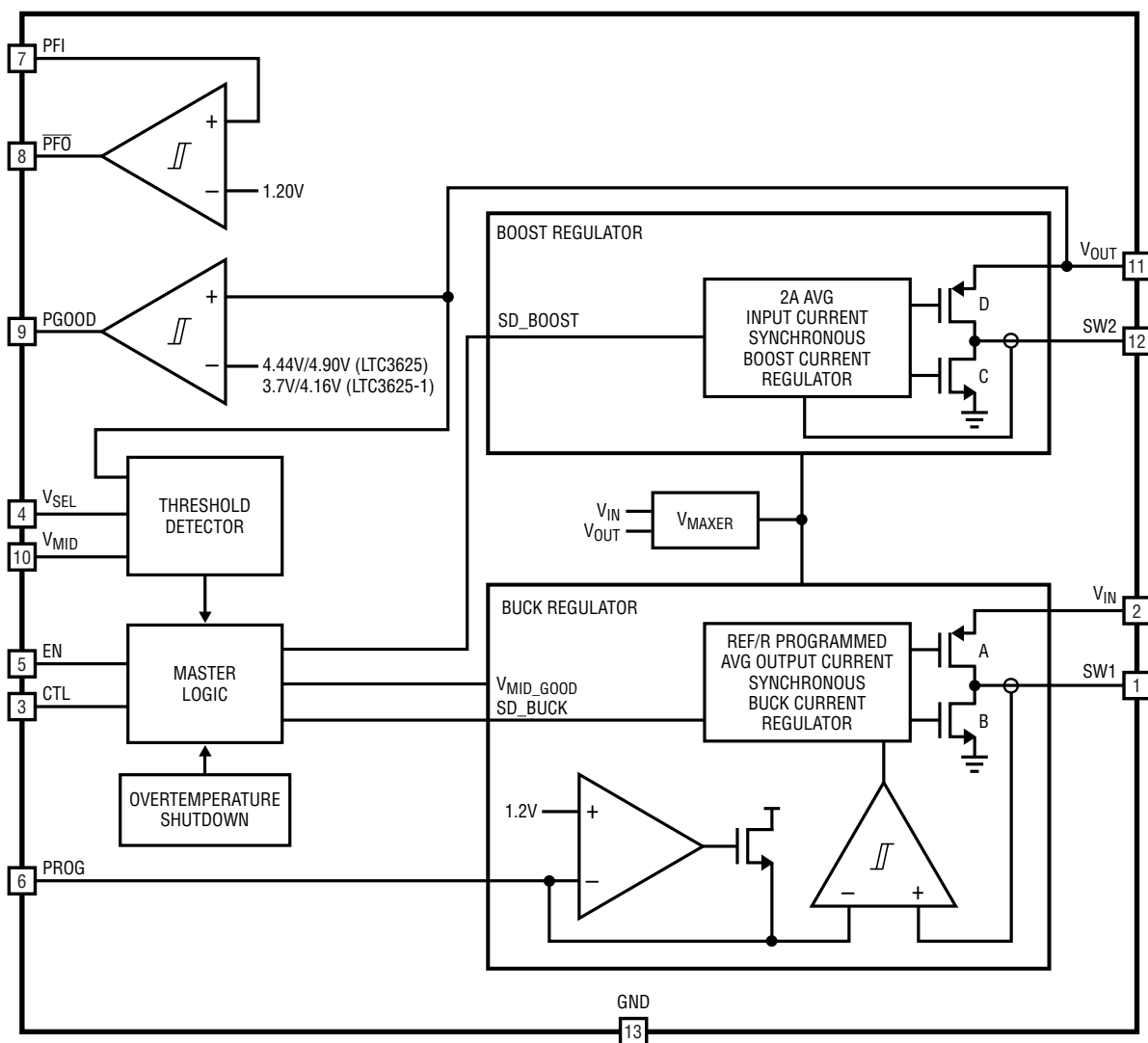

3625f

OPERATION

The LTC3625/LTC3625-1 are dual cell supercapacitor chargers. Their unique topology charges two series connected capacitors to a fixed output voltage with programmable charging current without overvoltageing either of the cells—even if they are severely mismatched. No balancing resistors are required. The LTC3625/LTC3625-1 include an internal buck converter between V_{IN} and V_{MID} to regulate the voltage on C_{BOT} (across the bottom capacitor) as well as an internal boost converter between V_{MID} and V_{OUT} to regulate the voltage on C_{TOP} (across the top capacitor). The output current of the buck converter is user-programmed via the PROG pin and the input current of the boost converter is set at 2A (typical).

Table 1 indicates the various functions of the LTC3625/LTC3625-1 that can be digitally controlled.

Table 1. Digital Input Functions

PIN	VALUE	FUNCTION
CTL*	0	Part runs in 2-inductor application
	1	Part runs in 1-inductor application
V _{SEL}	0	4.8V/4.0V sleep threshold
	1	5.3V/4.5V sleep threshold
EN	0	Part shuts down, V_{OUT} becomes high impedance
	1	Part enables and regulates the output

*CTL pin must be hard tied to either V_{IN} or GND.

V_{IN} Undervoltage Lockout (UVLO)

An internal undervoltage lockout circuit monitors V_{IN} and keeps the LTC3625/LTC3625-1 disabled until V_{IN} rises above 2.90V/2.63V (typical) if V_{SEL} is high or 2.63V/2.63V (typical) if V_{SEL} is low. Hysteresis on the UVLO turns off the LTC3625/LTC3625-1 if V_{IN} drops by approximately 100mV below the UVLO rising threshold. When in UVLO, only current needed to detect a valid input will be drawn from V_{IN} and V_{OUT} .

Buck Converter

The buck converter regulates a user-programmed average output current given by:

$$I_{BUCK} = h_{PROG} \cdot \frac{1.2V}{R_{PROG}}$$

where $h_{PROG} = 118,000$ (typical).

The buck converter regulates the current hysteretically by switching on the buck PMOS until a peak current limit is reached and then turning on the buck NMOS until a valley current limit is reached. In the single inductor application the boost NMOS is used in conjunction with the buck NMOS to increase efficiency at high currents. The forward current limit is set to $1.1 \cdot I_{BUCK}$ (typical) and the valley current limit is set to $0.9 \cdot I_{BUCK}$ (typical). Because of this method of regulation, overcurrent limit and reverse-current limit protection is automatically provided. The LTC3625/LTC3625-1 will continue to regulate its programmed current even into a grounded output.

In fault conditions where the PROG pin is shorted to ground, or R_{PROG} is conductive enough to program I_{BUCK} to operate outside of specification, the current out of the PROG pin will be clamped to 22.5 μ A (typical) and I_{BUCK} will be set to 2.65A (typical). If input current limit is not a concern, the PROG pin may be grounded to minimize charge times.

Boost Converter

The boost converter regulates a fixed average input current of 2A (typical). The current is regulated hysteretically by switching on the boost NMOS until the peak current limit of 2.12A (typical) is reached, and turning on the boost PMOS until the valley current limit of 1.88A (typical) is reached. In the single inductor application the buck NMOS is used in conjunction with the boost NMOS to increase efficiency. Because of this method of regulation, overcurrent limit and reverse-current limit protection is automatically provided.

In normal operation V_{OUT} will increase with V_{MID} so V_{OUT} should never be below V_{MID} . In the case where there is a reverse voltage on C_{TOP} due to a faulty precondition or a large load on the output, the boost converter will operate in trickle charge mode. In this mode the boost PMOS gate will remain high and instead allow the SW2 node to increase until $SW2 \approx V_{MAX} + 1V$ to allow a higher reverse voltage across the inductor, and the current is ramped down to 0mA. This will result in a less efficient charge delivery through the PMOS. To keep dissipation low, I_{PEAK} is limited to 200mA (typical). In this mode the discharge phase is terminated if it lasts longer than 6.5 μ s (typical).

The boost converter is disabled if V_{MID} falls below the $V_{MID(GOOD)}$ hysteresis threshold of 1.2V (typical).

OPERATION

Single Inductor Operation

With the CTL pin tied to V_{IN} the LTC3625/LTC3625-1 will operate in single inductor mode. In this mode the same inductor serves in the power path for both the buck and the boost converters. Thus, the buck converter and boost converter will never run simultaneously.

Under certain conditions with a single inductor, a small amount of current can flow from the supercapacitors to V_{IN} when the boost charger is active. A 25mA load is required on V_{IN} to prevent the V_{IN} supply from being pumped to a higher voltage while the boost is active. This minimum load is not needed in the two inductor application and it is also not needed when the charger is disabled.

A typical charge cycle for a fully discharged capacitor stack will proceed as follows:

1. The buck converter will turn on and regulate its output current ramping hysteretically between $1.1 \cdot I_{BUCK}$ and $0.9 \cdot I_{BUCK}$ until the $V_{MID(GOOD)}$ threshold is met (1.35V typical).
2. Once the $V_{MID(GOOD)}$ threshold is reached, the boost converter will turn on and regulate its input current ramping hysteretically between 2.12A and 1.88A until V_{MID} falls below the $V_{MID(GOOD)}$ hysteresis threshold (1.2V typical).
3. Phases 1 and 2 will alternate until V_{OUT} is approximately 2.4V. When V_{TOP} (equal to $V_{OUT} - V_{MID}$) is approximately $50\text{mV} > V_{MID}$, the boost regulator will turn off and the buck regulator will turn on. Likewise, when V_{MID} is approximately $50\text{mV} > V_{TOP}$, the boost regulator will turn on and the buck regulator will turn off.
4. Phase 3 will continue until V_{OUT} has reached its programmed output voltage. Once this happens, the part will enter sleep mode and only minimal power will be consumed (see the Electrical Characteristics table).
5. If the supercapacitors' self discharge or an external load cause the output to drop by more than 135mV (typical), then the LTC3625/LTC3625-1 will exit sleep mode and begin charging the appropriate supercapacitor.

In all cases whenever either of the converters is shut down, it will switch to its appropriate discharge phase (NMOS on for the buck and PMOS on for the boost) until

the inductor current reaches 0mA. This optimizes charge delivery to the output capacitors.

Charge time is dependant on the programmed buck output current as well as the value of the supercapacitors being charged. For estimating charge profiles in the single inductor application, see the Typical Performance Characteristics graph Charge Time vs R_{PROG} .

The effective average V_{OUT} referred charge current can be approximated as:

$$I_{CHARGE} \cong 0.5 \cdot I_{BUCK} \cdot \epsilon_{BOOST} \cdot \frac{2A}{I_{BUCK} + 2A}$$

where ϵ_{BOOST} is the boost converter efficiency, which is typically about 85% (see the Typical Performance Characteristics graph Boost Efficiency vs V_{TOP}).

Seen another way, this is the maximum steady-state load the part can support without losing V_{OUT} regulation.

Dual Inductor Operation

With the CTL pin tied to GND, the LTC3625/LTC3625-1 will operate in dual inductor mode. In this mode two inductors will serve as the power path for the buck and the boost converters. This will allow both the buck and the boost converter to run simultaneously. As a result, the total charge time will be greatly reduced at the cost of an additional board component.

A typical charge cycle for a fully discharged capacitor stack will proceed as follows:

1. The buck converter will turn on and regulate its output current ramping hysteretically between $1.1 \cdot I_{BUCK}$ and $0.9 \cdot I_{BUCK}$ until the $V_{MID(GOOD)}$ threshold is met (1.35V typical).
2. Once the $V_{MID(GOOD)}$ threshold is reached, the boost converter will turn on and regulate its input current ramping hysteretically between 2.12A and 1.88A. The buck converter will continue to run at the same time. In some cases ($I_{BUCK} \sim <1\text{A}$) the boost converter's input current will exceed the current delivered to C_{BOT} ; even though the buck converter is running, charge will be removed and V_{MID} may decrease. Thus, if V_{MID} falls below the $V_{MID(GOOD)}$ hysteresis threshold, the boost

OPERATION

converter will turn off. Once V_{MID} has again risen above the $V_{MID(GOOD)}$ threshold, the boost converter will be re-enabled. In the case where $V_{OUT} < V_{MID}$, the boost converter will operate in trickle charge mode until V_{OUT} exceeds V_{MID} (see Boost Converter).

3. During phase 2, if C_{BOT} exceeds its individual maximum threshold voltage (2.45V/2.05V typical if V_{SEL} is low or 2.7V/2.3V typical if V_{SEL} is high) or if V_{TOP} exceeds V_{BOT} by more than 50mV (typical), then the appropriate converter will turn off until the capacitor has fallen below its hysteresis threshold (2.40V/2V typical if V_{SEL} is low and 2.65V/2.25V typical if V_{SEL} is high for the buck converter or $V_{TOP} < V_{MID} - 50mV$ typical for the boost converter).
4. Once V_{OUT} has reached its programmed output voltage, the part will enter sleep mode, and only minimal power will be consumed (see the Electrical Characteristics table).
5. If the supercapacitors' self discharge or an external load cause the output to drop by more than 135mV (typical), then the LTC3625/LTC3625-1 will exit sleep mode and begin recharging the supercapacitor stack.

In all cases, whenever either of the converters is shut down, it will switch to its appropriate discharge phase (NMOS on for the buck and PMOS on for the boost) until the inductor current reaches 0mA. This optimizes charge delivery to the output capacitors.

Charge time is dependent on the programmed buck output current as well as the value of supercapacitors being charged. For estimating charge profiles in the dual inductor application, see the Typical Performance Characteristics graph Charge Time vs R_{PROG} .

The effective average V_{OUT} referred charge current, while both converters are continuously active, can be approximated as:

$$I_{CHARGE} \cong 0.5 \cdot I_{BUCK} - 1A \cdot \left(1 - 2 \cdot \epsilon_{BOOST} \cdot \frac{V_{MID}}{V_{OUT}} \right)$$

And, while both supercapacitors are in balance and V_{MID} is above the $V_{MID(GOOD)}$ threshold as:

$$I_{CHARGE} \cong 0.5 \cdot I_{BUCK} \cdot \epsilon_{BOOST}$$

where ϵ_{BOOST} is the boost converter efficiency which is typically around 85% (see the Typical Performance Characteristics graph Boost Efficiency vs V_{TOP}).

Seen another way this is the maximum steady-state load the part can support without losing V_{OUT} regulation.

PGOOD PIN

The PGOOD pin is an open-drain output used to indicate that V_{OUT} has approached its final regulation value. PGOOD remains active low until V_{OUT} reaches 92.5% of its regulation value at which point it will become high impedance. If V_{OUT} falls below 89.5% of its regulation voltage after PGOOD has been asserted, PGOOD will once again pull active low. PGOOD is an open-drain output and requires a pull-up resistor to the input voltage of the monitoring microprocessor or another appropriate power source. PGOOD is pulled active low in shutdown or input UVLO.

Power-Fail Input Comparator

The PFI/ $\overline{PF0}$ pins provide an input failure notification to the user. The PFI pin is a high impedance input pin that should be tied to a resistive divider from V_{IN} . $\overline{PF0}$ is an open-drain output and requires a pull-up resistor to the input voltage of the monitoring microprocessor or another appropriate power source. When PFI is above 1.2V, $\overline{PF0}$ is high impedance and will be pulled up through the external resistor. If PFI drops below 1.2V, $\overline{PF0}$ will be pulled low indicating a power failure. This allows the user to program any desired input power failure indication threshold. There is 15mV of hysteresis on the PFI pin. If this functionality is not desired the PFI pin should be tied to V_{IN} . $\overline{PF0}$ is pulled active low in shutdown or input UVLO.

Shutdown Operation

When the EN pin is pulled low the LTC3625/LTC3625-1 are put into shutdown. In this case, all of the active circuitry is powered down and there will be less than 1 μ A of leakage current from both V_{IN} and V_{OUT} . This allows the input to be present or absent as well as the capacitor stacks to be fully charged or discharged in shutdown without leakage between V_{IN} , V_{OUT} and GND.

APPLICATIONS INFORMATION

Programming Charge Current/Maximum Input Current

The C_{BOT} charge current is programmed with a single resistor connecting the PROG pin to ground. The program resistor and buck output current are calculated using the following equation:

$$R_{PROG} = h_{PROG} \cdot \frac{1.2V}{I_{BUCK}}$$

where $h_{PROG} = 118,000$ (typical). Excluding quiescent current, I_{BUCK} is always greater than the average buck input current. An R_{PROG} resistor value of less than 53.6k will cause the LTC3625/LTC3625-1 to enter overcurrent protection mode and proceed to charge at 2.65A (typical).

The effective buck input current can be calculated as:

$$I_{VIN} = \frac{I_{BUCK}}{\epsilon_{BUCK}} \cdot \frac{V_{MID}}{V_{IN}}$$

where ϵ_{BUCK} is the buck converter efficiency (see the Typical Performance Characteristics graph Buck Efficiency vs V_{MID}).

Output Voltage Programming

The LTC3625/LTC3625-1 have a V_{SEL} input pin that allows the user to set the output threshold voltage to either 4.8V/4.0V or 5.3V/4.5V by forcing a low or high at the V_{SEL} pin respectively. In the single inductor application the chip will balance the supercapacitors to within 50mV (typical) of each other, resulting in a possible 25mV of over/undercharge per cell. In the dual inductor application the chip will balance the supercapacitors to within 100mV (typical) of each other, resulting in a possible 50mV of over/undercharge per cell.

Thermal Management

If the junction temperature increases above approximately 150°C, the thermal shutdown circuitry automatically deactivates the output. To reduce the maximum junction temperature, a good thermal connection to the PC board is recommended. Connecting the exposed pad (Pin 13) of the DFN package to a ground plane under the device on two layers of the PC board, will reduce the thermal resistance of the package and PC board considerably.

V_{IN} Capacitor Selection

The style and value of capacitors used with the LTC3625/LTC3625-1 determine input voltage ripple. Because the LTC3625/LTC3625-1 use a step-down switching power supply from V_{IN} to V_{MID} , its input current waveform contains high frequency components. It is strongly recommended that a low equivalent series resistance (ESR) multilayer ceramic capacitor be used to bypass V_{IN} .

Tantalum and aluminum capacitors are not recommended because of their high ESR. The value of the capacitor on V_{IN} directly controls the amount of input ripple for a given I_{BUCK} . Increasing the size of this capacitor will reduce the input ripple.

Multilayer ceramic chip capacitors typically have exceptional ESR performance. MLCCs combined with a tight board layout and an unbroken ground plane will yield very good performance and low EMI emissions. There are several types of ceramic capacitors available, each having considerably different characteristics. For example, X7R ceramic capacitors have the best voltage and temperature stability. X5R ceramic capacitors have higher packing density but poorer performance over their rated voltage and temperature ranges. Y5V ceramic capacitors have the highest packing density, but must be used with caution because of their extreme non-linear characteristic of capacitance versus voltage.

The actual in-circuit capacitance of a ceramic capacitor should be measured with a small AC signal as is expected in-circuit. Many vendors specify the capacitance versus voltage with a $1V_{RMS}$ AC test signal and as a result, overstate the capacitance that the capacitor will present in the application. Using similar operating conditions as the application, the user must measure or request from the vendor the actual capacitance to determine if the selected capacitor meets the minimum capacitance that the application requires.

Inductor Selection

Many different sizes and shapes of inductors are available from numerous manufacturers. Choosing the right inductor from such a large selection of devices can be overwhelming, but following a few basic guidelines will make the selection process much simpler.

APPLICATIONS INFORMATION

The buck and boost converters are designed to work with inductors over a wide range of inductances. Choosing a higher valued inductor will decrease operating frequencies, while a lower valued inductor will increase frequency but also increase peak current overshoot/undershoot. For most applications a 3.3µH inductor is recommended. To maximize efficiency, choose an inductor with a low DC resistance. Choose an inductor with a DC current rating at least as large as the maximum I_{PEAK} the application will see according to the specifications table to ensure that the inductor does not saturate during normal operation. If the single inductor application is used, make sure to size the inductor for the higher of buck or boost peak currents.

Different core materials and shapes will change the size/current and price/current relationship of an inductor. Toroid or shielded pot cores in ferrite or Permalloy materials are small and do not radiate much energy, but generally cost more than powdered iron core inductors with similar electrical characteristics. Inductors that are very thin or have a very small volume typically have much higher core and DCR losses, and will not give the best efficiency. The choice of which style inductor to use often depends more on the price versus size, performance and any radiated EMI requirements than on what the LTC3625/LTC3625-1 family requires to operate.

Table 2 shows several inductors that work well with the LTC3625/LTC3625-1 regulators. These inductors offer a

good compromise in current rating, DCR and physical size. Consult each manufacturer for detailed information on their entire selection of inductors.

Supercapacitor Selection

The LTC3625/LTC3625-1 are designed to charge supercapacitors of values greater than 0.1F per cell. In general, lower capacitance cells have higher ESRs, therefore lower charge currents should be used to help reduce sleep modulation towards the end of a charge cycle. In general, the ESR of a supercapacitor cell should not exceed:

$$ESR \leq \frac{100\text{mV}}{I_{BUCK}}$$

where 100mV is the sleep threshold hysteresis. Higher capacitance cells typically have lower ESRs and can therefore be charged with higher currents. Typically, the LTC3625/LTC3625-1 are designed to charge supercapacitors with values up to 100F, but higher capacitance cells could be used at the expense of greater charge time. Table 3 shows several supercapacitors that work well with the LTC3625/LTC3625-1.

Printed Circuit Board Layout Considerations

In order to be able to deliver maximum current under all conditions, it is critical that the exposed pad on the backside of the LTC3625/LTC3625-1 package be soldered to the PC

Table 2. Inductor Manufacturers

MANUFACTURER	PART NUMBER	INDUCTANCE (µH)	CURRENT (A)	DCR (mΩ)	SIZE (mm)
Coiltronics	DR73-3R3-R	3.3	3.0	20	7 × 7
Coilcraft	MSS7341-332NL	3.3	3.2	20	7 × 7
Vishay	IHLM2525CZER3R3M11	3.3	6.5	26	6.5 × 6.9
Sumida	CDRH6D28P-3RON	3.0	3.0	24	7 × 7
TOKO	B1077AS-3RON	3.0	3.3	30	7.6 × 7.6

Table 3. Supercapacitor Manufacturers

MANUFACTURER	PART NUMBER	VALUE (F)	OPERATING VOLTAGE (V)	MAXIMUM ESR (mΩ)	SIZE (mm)
Cooper Bussmann	B1860-2R5107-R	100	2.5	20	18 × 60
Illinois Capacitor	107DCN2R7M	100	2.7	10	22 × 45
NESS Capacitor	ESHSR-0100C0002R7	100	2.7	9	22 × 45
Tecate	TPLS-100//22 X 45F	100	2.7	9	22 × 45
Maxwell	BCAP120P250	120	2.5	2.5	26 × 51

3625f

TYPICAL APPLICATIONS

Solar Powered SCAP Charger with MPPT

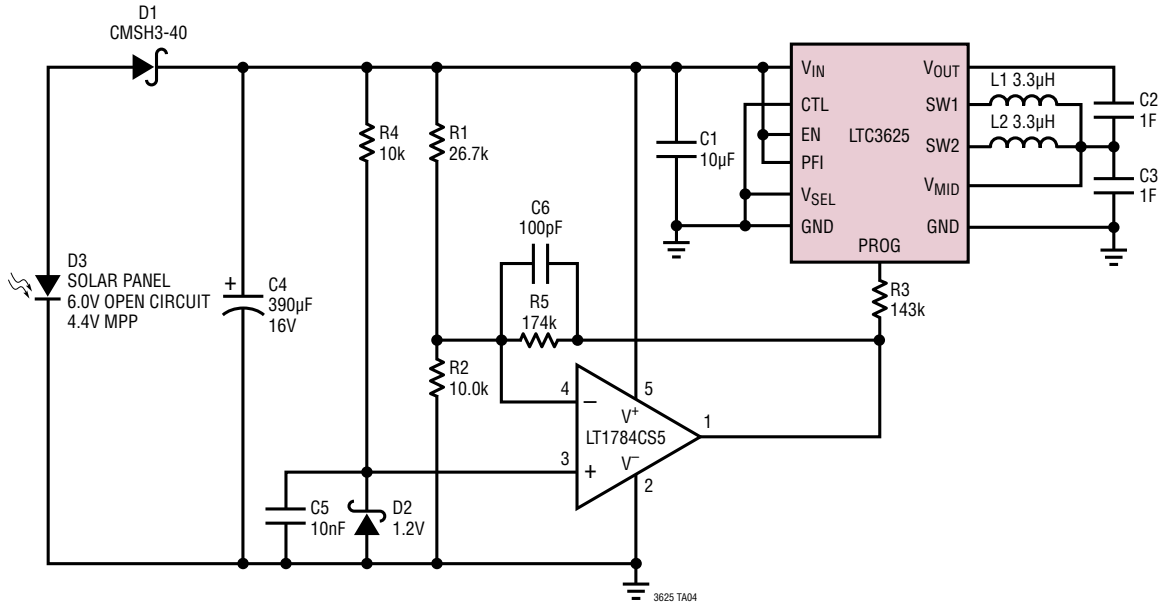

5V Power Ride-Through

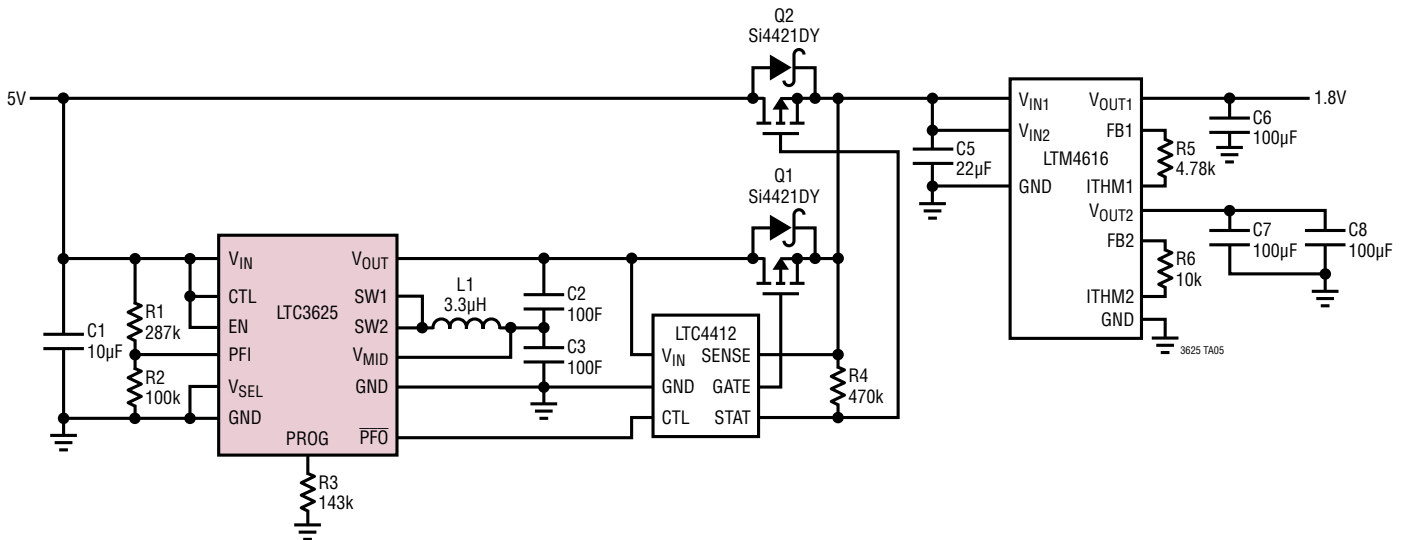

TYPICAL APPLICATIONS

12V Power Ride-Through

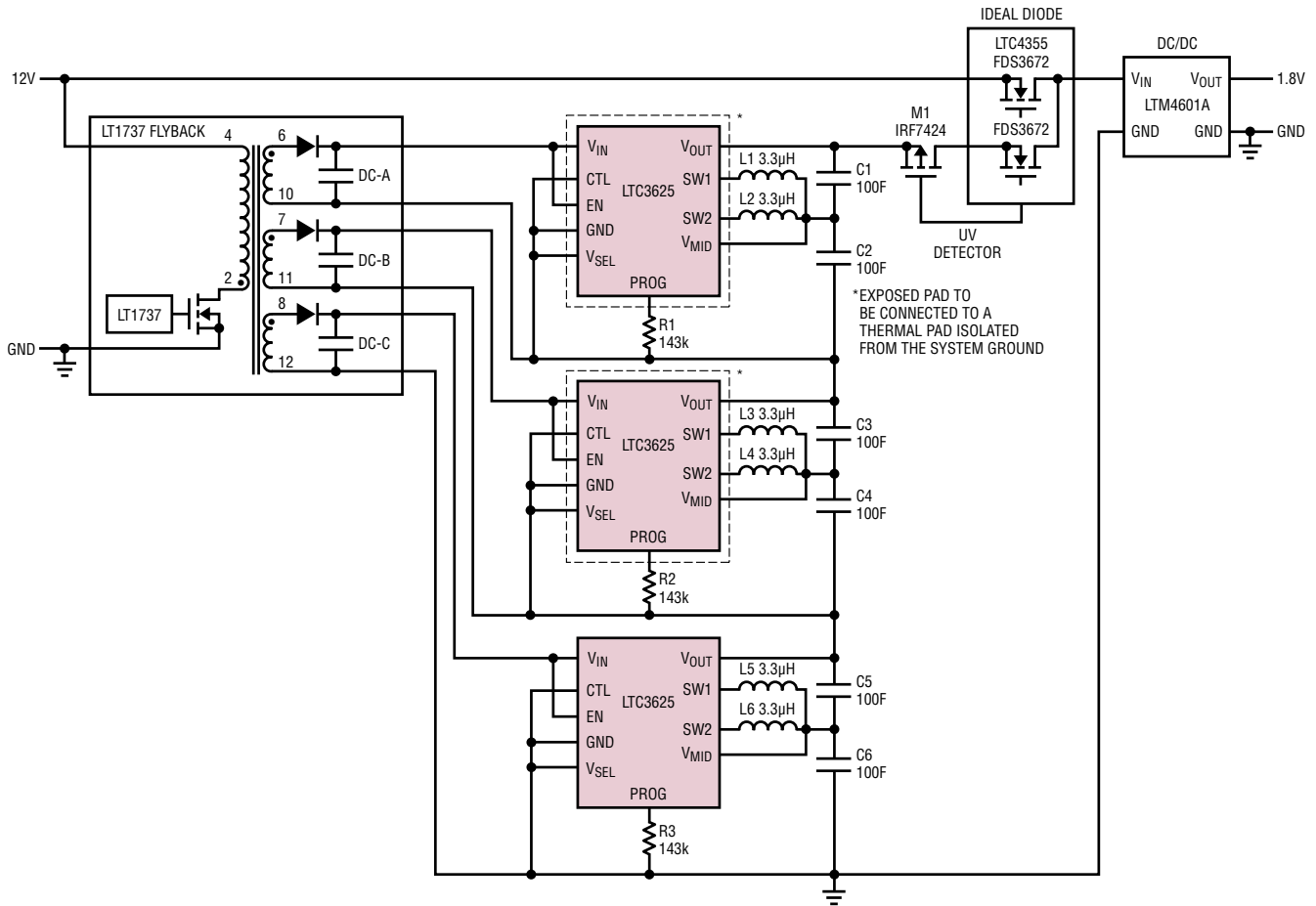

PACKAGE DESCRIPTION

DE Package 12-Lead Plastic DFN (4mm × 3mm) (Reference LTC DWG # 05-08-1695)

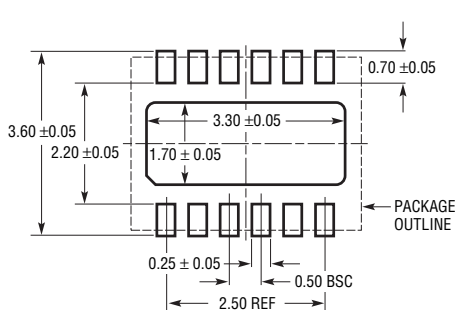

RECOMMENDED SOLDER PAD PITCH AND DIMENSIONS
APPLY SOLDER MASK TO AREAS THAT ARE NOT SOLDERED

- NOTE:
1. DRAWING PROPOSED TO BE A VARIATION OF VERSION (WGED) IN JEDEC PACKAGE OUTLINE MO-229
 2. DRAWING NOT TO SCALE
 3. ALL DIMENSIONS ARE IN MILLIMETERS

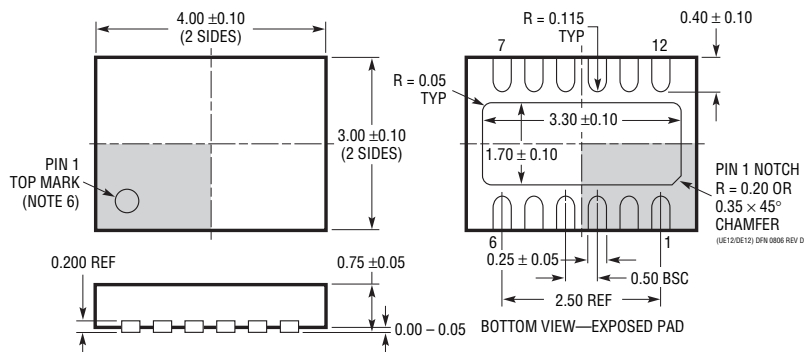

3. ALL DIMENSIONS ARE IN MILLIMETERS
4. DIMENSIONS OF EXPOSED PAD ON BOTTOM OF PACKAGE DO NOT INCLUDE MOLD FLASH. MOLD FLASH, IF PRESENT, SHALL NOT EXCEED 0.15mm ON ANY SIDE
5. EXPOSED PAD SHALL BE SOLDER PLATED
6. SHADED AREA IS ONLY A REFERENCE FOR PIN 1 LOCATION ON THE TOP AND BOTTOM OF PACKAGE

TYPICAL APPLICATION

Minimum External Component Application (500mA Charge Current)

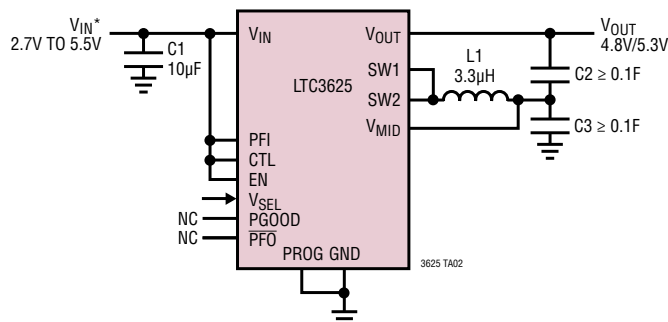



*25mA MINIMUM LOAD REQUIRED ON V_{IN}

RELATED PARTS

PART NUMBER	DESCRIPTION	COMMENTS
LTC3203/LTC3203B/ LTC3203B-1/LTC3203-1	500mA Low Noise High Efficiency Dual Mode Step-Up Charge Pumps	V _{IN} : 2.7V to 5.5V, 3mm × 3mm 10-Lead DFN Package
LTC3204/LTC3204B-3.3/ LTC3204-5	Low Noise Regulating Charge Pumps	Up to 150mA Output Current (LTC3204-5), Up to 50mA Output Current (LTC3204-3.3)
LTC3221/LTC3221-3.3/ LTC3221-5	Micropower Regulated Charge Pump	Up to 60mA Output Current
LTC3225/LTC3225-1	150mA Supercapacitor Charger	Programmable Supercapacitor Charger Designed to Charge Two Supercapacitors in Series to a Fixed Output Voltage (4.8V/5.3V Selectable) from a 2.8V/3V to 5.5V Input Supply. Automatic Cell Balancing Prevents Overvoltage Damage to Either Supercapacitor. No Balancing Resistors are Required.
LTC3240-3.3/LTC3240-2.5	Step-Up/Step-Down Regulated Charge Pumps	Up to 150mA Output Current
LT [®] 3420/LT3420-1	1.4A/1A Photoflash Capacitor Charger with Automatic Top-Off	Charges 220µF to 320V in 3.7 Seconds from 5V, V _{IN} : 2.2V to 16V, I _{SD} < 1µA, 10-Lead MS Package
LT3468/LT3468-1/ LT3468-2	1.4A/1A/0.7A, Photoflash Capacitor Charger	V _{IN} : 2.5V to 16V, Charge Time = 4.6 Seconds for the LT3468 (0V to 320V, 100µF V _{IN} = 3.6V), I _{SD} < 1µA, ThinSOT™ Package
LTC3484-0/LTC3484-1/ LTC3484-2	1.4A/0.7A/1A, Photoflash Capacitor Charger	V _{IN} : 1.8V to 16V, Charge Time = 4.6 Seconds for the LTC3484-0 (0V to 320V, 100µF V _{IN} = 3.6V), I _{SD} < 1µA, 2mm × 3mm 6-Lead DFN Package
LT3485-0/LT3485-1/ LT3485-2/LT3485-3	1.4A/0.7A/1A/2A Photoflash Capacitor Charger with Output Voltage Monitor and Integrated IGBT	V _{IN} : 1.8V to 10V, Charge Time = 3.7 Seconds for the LT3485-0 (0V to 320V, 100µF V _{IN} = 3.6V), I _{SD} < 1µA, 3mm × 3mm 10-Lead DFN Driver
LT3750	Capacitor Charger Controller	Charges Any Size Capacitor, 10-Lead MS Package
LT3751	Capacitor Controller with Regulation	Charges Any Size Capacitor, 4mm × 5mm QFN-20 Package
LTC4425	Supercapacitor Charger with Current-Limited Ideal Diode	CC/CV Linear Charger for 2-Cell Supercapacitor Stack from a Li-Ion/ Polymer Battery, USB Port or a 2.7V to 5.5V Current-Limited Supply, 3mm × 3mm DFN-12 and MSOP-12E Packages

Looking for pricing, stock, or lifecycle information?

Click below to explore more details on WIN SOURCE:

-  [View LTC3625IDE-1#PBF on WIN SOURCE](#)
-  [Analog Devices Inc. Information](#)

Optimize Your Supply Chain with WIN SOURCE Solutions

-  Global Sourcing Solution
-  Obsolete Management
-  Cost Control Management
-  Shortage Management
-  Alternative Solution
-  Excess Inventory Management