

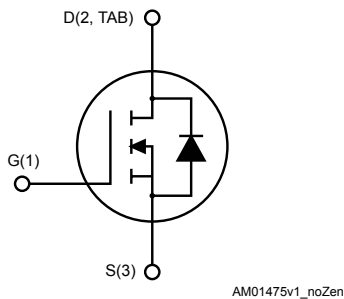

THE DATASHEET OF 16NF25



N-channel 250 V, 0.195 Ω typ., 14 A STripFET™ II Power MOSFETs in DPAK and TO-220FP packages



Features

Order code	V_{DS}	$R_{DS(on)}$ max.	I_D	Package
STD16NF25	250 V	0.235 Ω	14 A	DPAK
STF16NF25				TO-220FP

- Exceptional dv/dt capability
- 100% avalanche tested
- Low gate charge

Applications

- Switching applications

Description

These Power MOSFETs have been developed using STMicroelectronics' unique STripFET process, which is specifically designed to minimize input capacitance and gate charge. This renders the devices suitable for use as primary switch in advanced high-efficiency isolated DC-DC converters for telecom and computer applications, and applications with low gate charge driving requirements.



Product status link

[STD16NF25](#)
[STF16NF25](#)

1 Electrical ratings

Table 1. Absolute maximum ratings

Symbol	Parameter	Value		Unit
		DPAK	TO-220FP	
V_{DS}	Drain-source voltage	250		V
V_{GS}	Gate-source voltage	±20		V
I_D	Drain current (continuous) at $T_C = 25\text{ °C}$	14	14 ⁽¹⁾	A
I_D	Drain current (continuous) at $T_C = 100\text{ °C}$	8.8	8.8 ⁽¹⁾	A
I_{DM} ⁽²⁾	Drain current (pulsed)	56	56 ⁽¹⁾	A
P_{TOT}	Total power dissipation at $T_C = 25\text{ °C}$	85	25	W
dv/dt ⁽³⁾	Peak diode recovery voltage slope	15		V/ns
V_{ISO}	Insulation withstand voltage (RMS) from all three leads to external heat sink ($t = 1\text{ s}$; $T_C = 25\text{ °C}$)		2.5	kV
T_j	Operating junction temperature range	-55 to 150		°C
T_{stg}	Storage temperature range			

- Limited by maximum junction temperature.
- Pulse width limited by safe operating area.
- $I_{SD} \leq 13\text{ A}$, $di/dt \leq 300\text{ A}/\mu\text{s}$, $V_{DD} = 80\% V_{(BR)DSS}$, $T_j \leq T_{JMAX}$.

Table 2. Thermal data

Symbol	Parameter	Value		Unit
		DPAK	TO-220FP	
$R_{thj-case}$	Thermal resistance junction-case	1.47	5	°C/W
$R_{thj-pcb}$ ⁽¹⁾	Thermal resistance junction-pcb	50		
$R_{thj-amb}$	Thermal resistance junction-ambient		62.5	

- When mounted on FR-4 board of 1 inch², 2 oz Cu.

Table 3. Avalanche characteristics

Symbol	Parameter	Value	Unit
I_{AR} ⁽¹⁾	Avalanche current, repetitive or not-repetitive	13	A
E_{AS} ⁽²⁾	Single pulse avalanche energy	100	mJ

- Pulse width limited by T_{jmax} .
- Starting $T_j = 25\text{ °C}$, $I_D = I_{AR}$, $V_{DD} = 50\text{ V}$.

2 Electrical characteristics

($T_{CASE} = 25\text{ °C}$ unless otherwise specified)

Table 4. On/off states

Symbol	Parameter	Test conditions	Min.	Typ.	Max.	Unit
$V_{(BR)DSS}$	Drain-source breakdown voltage	$V_{GS} = 0\text{ V}$, $I_D = 1\text{ mA}$	250			V
I_{DSS}	Zero gate voltage drain current	$V_{GS} = 0\text{ V}$, $V_{DS} = 250\text{ V}$			1	μA
		$V_{GS} = 0\text{ V}$, $V_{DS} = 250\text{ V}$, $T_C = 125\text{ °C}$ ⁽¹⁾			10	μA
I_{GSS}	Gate-body leakage current	$V_{DS} = 0\text{ V}$, $V_{GS} = \pm 20\text{ V}$			± 100	nA
$V_{GS(th)}$	Gate threshold voltage	$V_{DS} = V_{GS}$, $I_D = 250\text{ }\mu\text{A}$	2	3	4	V
$R_{DS(on)}$	Static drain-source on resistance	$V_{GS} = 10\text{ V}$, $I_D = 6.5\text{ A}$		0.195	0.235	Ω

1. Defined by design, not subject to production test.

Table 5. Dynamic

Symbol	Parameter	Test conditions	Min.	Typ.	Max.	Unit
C_{iss}	Input capacitance	$V_{DS} = 25\text{ V}$, $f = 1\text{ MHz}$, $V_{GS} = 0\text{ V}$	-	680	-	μF
C_{oss}	Output capacitance			125		
C_{rss}	Reverse transfer capacitance			20		
$C_{oss\text{ eq.}}$ ⁽¹⁾	Equivalent output capacitance	$V_{GS} = 0\text{ V}$, $V_{DS} = 0\text{ V to } 200\text{ V}$	-	48	-	μF
R_G	Gate input resistance	$f = 1\text{ MHz}$, $I_D = 0\text{ A}$	-	2.1	-	Ω
Q_g	Total gate charge	$V_{DD} = 200\text{ V}$, $I_D = 13\text{ A}$, $V_{GS} = 0\text{ to } 10\text{ V}$ (see Figure 16. Test circuit for gate charge behavior)	-	18	-	nC
Q_{gs}	Gate-source charge			3		
Q_{gd}	Gate-drain charge			9		

1. $C_{oss\text{ eq.}}$ is defined as a constant equivalent capacitance giving the same charging time as C_{oss} when V_{DS} increases from 0 to 80% V_{DSS} .

Table 6. Switching times

Symbol	Parameter	Test conditions	Min.	Typ.	Max.	Unit
$t_{d(on)}$	Turn-on delay time	$V_{DD} = 125\text{ V}$, $I_D = 6.5\text{ A}$, $R_G = 4.7\text{ }\Omega$, $V_{GS} = 10\text{ V}$ (see Figure 15. Test circuit for resistive load switching times and Figure 20. Switching time waveform)	-	9	-	ns
t_r	Rise time			17		
$t_{d(off)}$	Turn-off delay time			35		
t_f	Fall time			17		

Table 7. Source-drain diode

Symbol	Parameter	Test conditions	Min.	Typ.	Max.	Unit
I_{SD}	Source-drain current		-		14	A
$I_{SDM}^{(1)}$	Source-drain current (pulsed)		-		56	
$V_{SD}^{(2)}$	Forward on voltage	$I_{SD} = 13\text{ A}$, $V_{GS} = 0\text{ V}$	-		1.6	V
t_{rr}	Reverse recovery time	$I_{SD} = 13\text{ A}$, $di/dt = 100\text{ A}/\mu\text{s}$	-	133		ns
Q_{rr}	Reverse recovery charge	$V_{DD} = 60\text{ V}$ (see Figure 17. Test circuit for inductive load switching and diode recovery times)	-	651		nC
I_{RRM}	Reverse recovery current		-	10		A
t_{rr}	Reverse recovery time	$I_{SD} = 13\text{ A}$, $di/dt = 100\text{ A}/\mu\text{s}$	-	157		ns
Q_{rr}	Reverse recovery charge	$V_{DD} = 60\text{ V}$, $T_j = 150\text{ }^\circ\text{C}$ (see Figure 17. Test circuit for inductive load switching and diode recovery times)	-	895		nC
I_{RRM}	Reverse recovery current		-	11		A

1. Pulse width is limited by safe operating area.
2. Pulsed: pulse duration = 300 μs , duty cycle 1.5%.

2.1 Electrical characteristics (curves)

Figure 1. Safe operating area for DPAK

Figure 2. Thermal impedance for DPAK

Figure 3. Safe operating area for TO-220FP

Figure 4. Thermal impedance for TO-220FP

Figure 5. Output characteristics

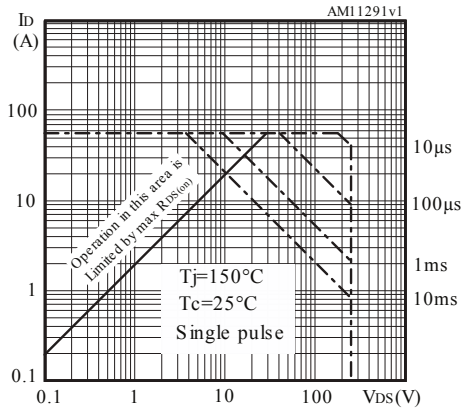
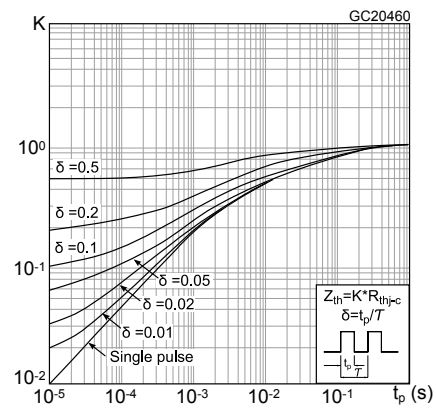
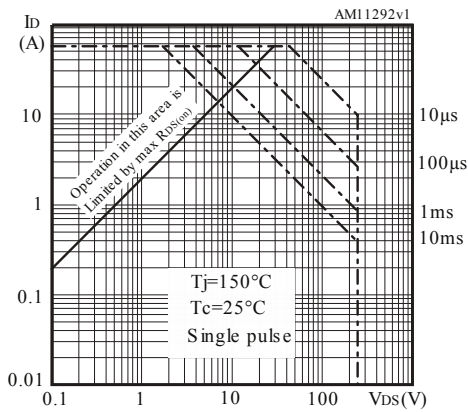
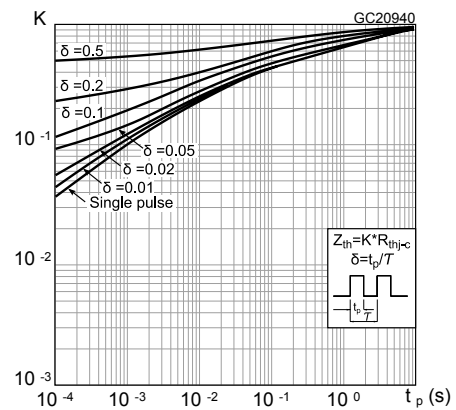
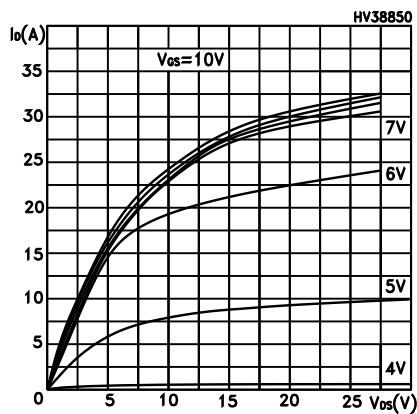
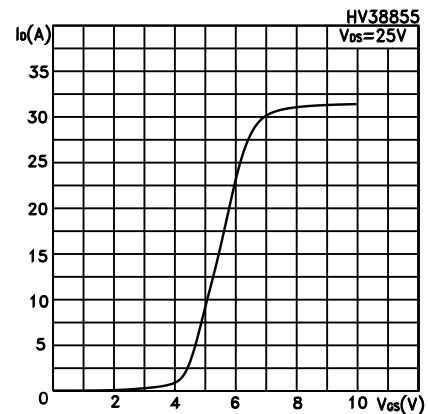
Figure 6. Transfer characteristics

Figure 7. Normalized $V_{(BR)DSS}$ vs temperature

Figure 8. Static drain-source on resistance

Figure 9. Gate charge vs gate-source voltage

Figure 10. Capacitance variations

Figure 11. Normalized gate threshold voltage vs temperature

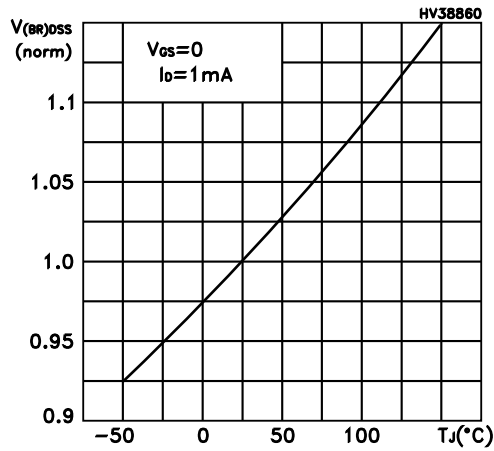
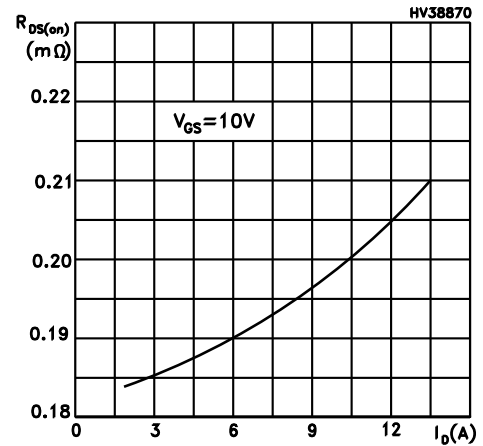
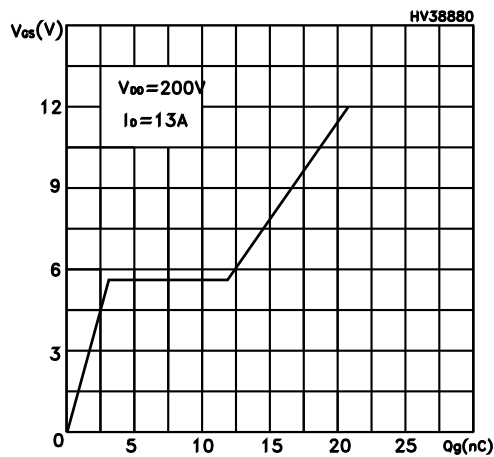
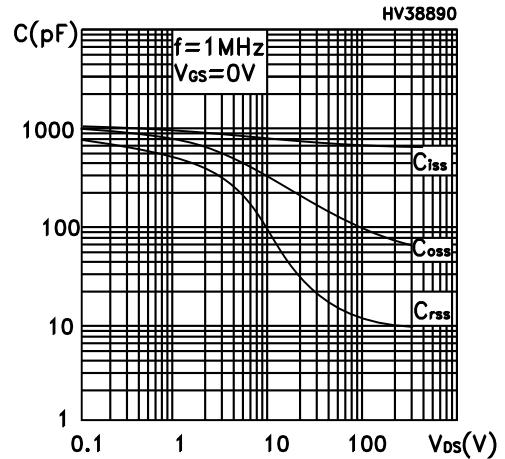
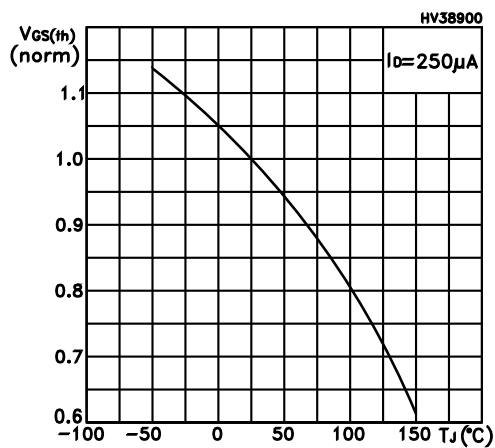
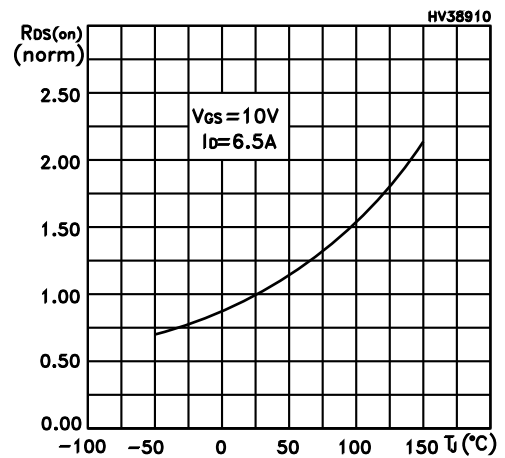
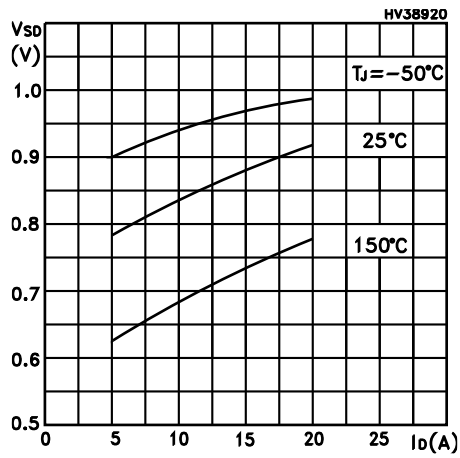
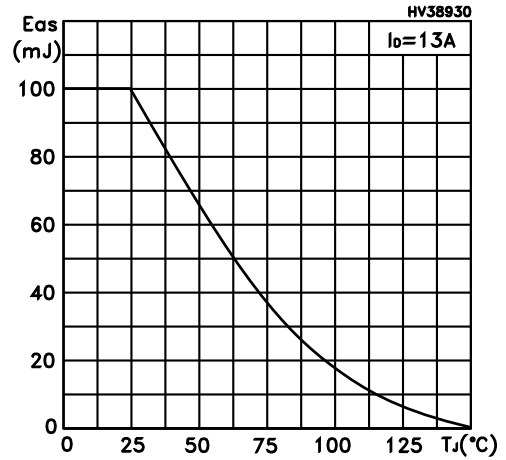
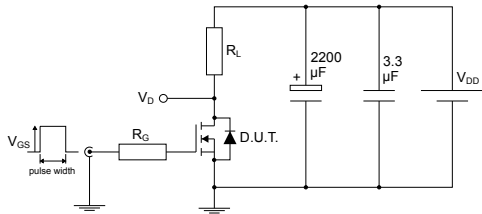
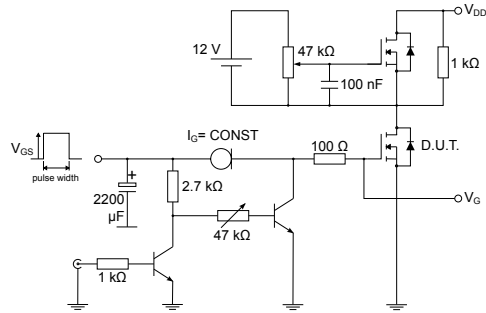
Figure 12. Normalized on resistance vs temperature

Figure 13. Source-drain diode forward characteristics

Figure 14. Maximum avalanche energy vs temperature

3 Test circuits

Figure 15. Test circuit for resistive load switching times

AM01468v1

Figure 16. Test circuit for gate charge behavior

AM01469v1

Figure 17. Test circuit for inductive load switching and diode recovery times



AM01470v1

Figure 18. Unclamped inductive load test circuit

AM01471v1

Figure 19. Unclamped inductive waveform

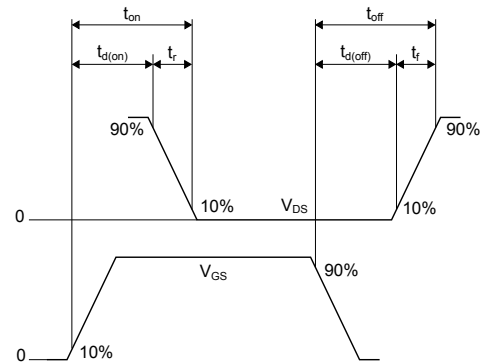
AM01472v1

Figure 20. Switching time waveform

AM01473v1

4 Package information

In order to meet environmental requirements, ST offers these devices in different grades of **ECOPACK[®]** packages, depending on their level of environmental compliance. ECOPACK[®] specifications, grade definitions and product status are available at: www.st.com. ECOPACK[®] is an ST trademark.

4.1 DPAK (TO-252) type A package information

Figure 21. DPAK (TO-252) type A package outline

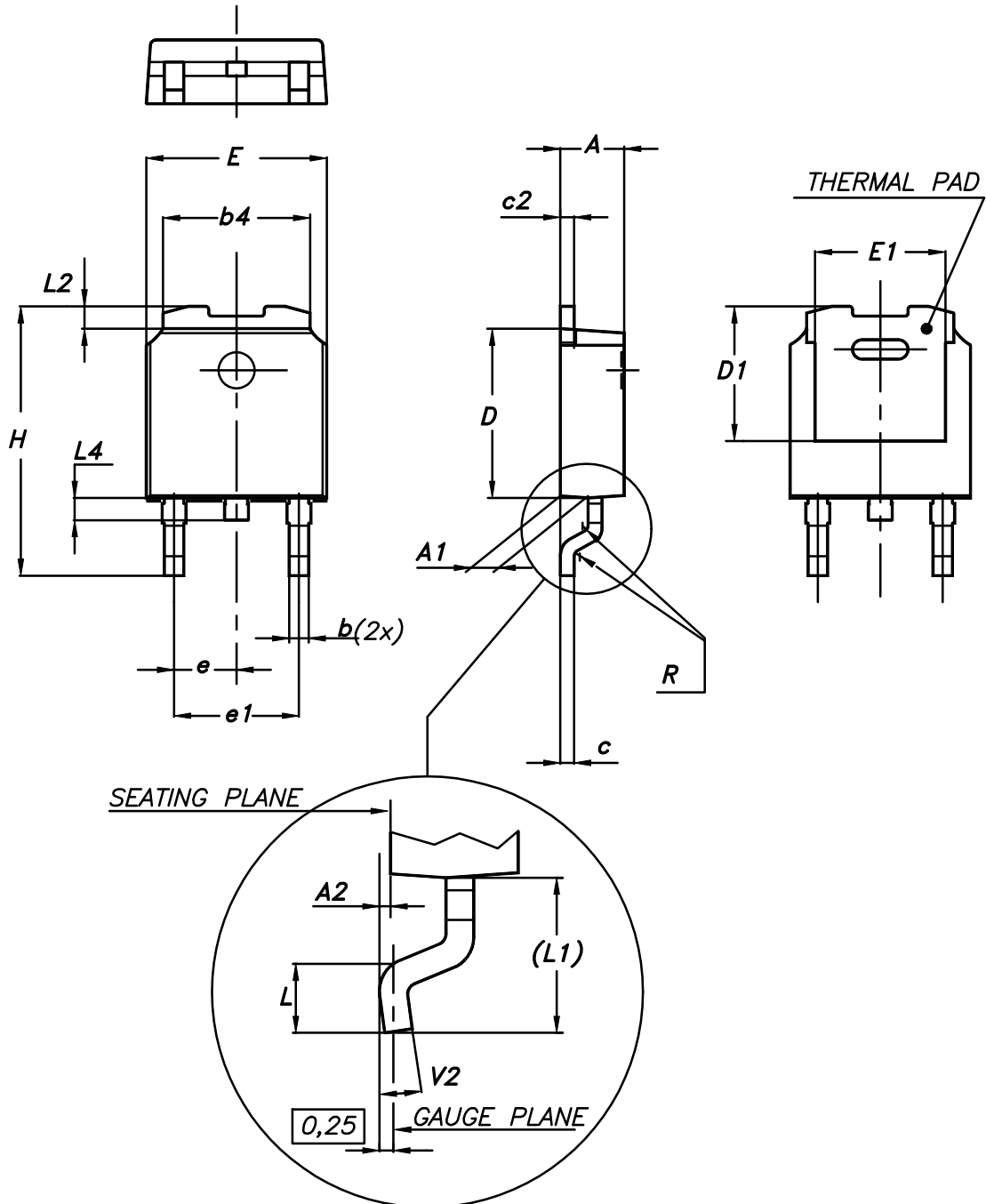

0068772_A_26

Table 8. DPAK (TO-252) type A mechanical data

Dim.	mm		
	Min.	Typ.	Max.
A	2.20		2.40
A1	0.90		1.10
A2	0.03		0.23
b	0.64		0.90
b4	5.20		5.40
c	0.45		0.60
c2	0.48		0.60
D	6.00		6.20
D1	4.95	5.10	5.25
E	6.40		6.60
E1	4.60	4.70	4.80
e	2.159	2.286	2.413
e1	4.445	4.572	4.699
H	9.35		10.10
L	1.00		1.50
(L1)	2.60	2.80	3.00
L2	0.65	0.80	0.95
L4	0.60		1.00
R		0.20	
V2	0°		8°

4.2 DPAK (TO-252) type C2 package information

Figure 22. DPAK (TO-252) type C2 package outline

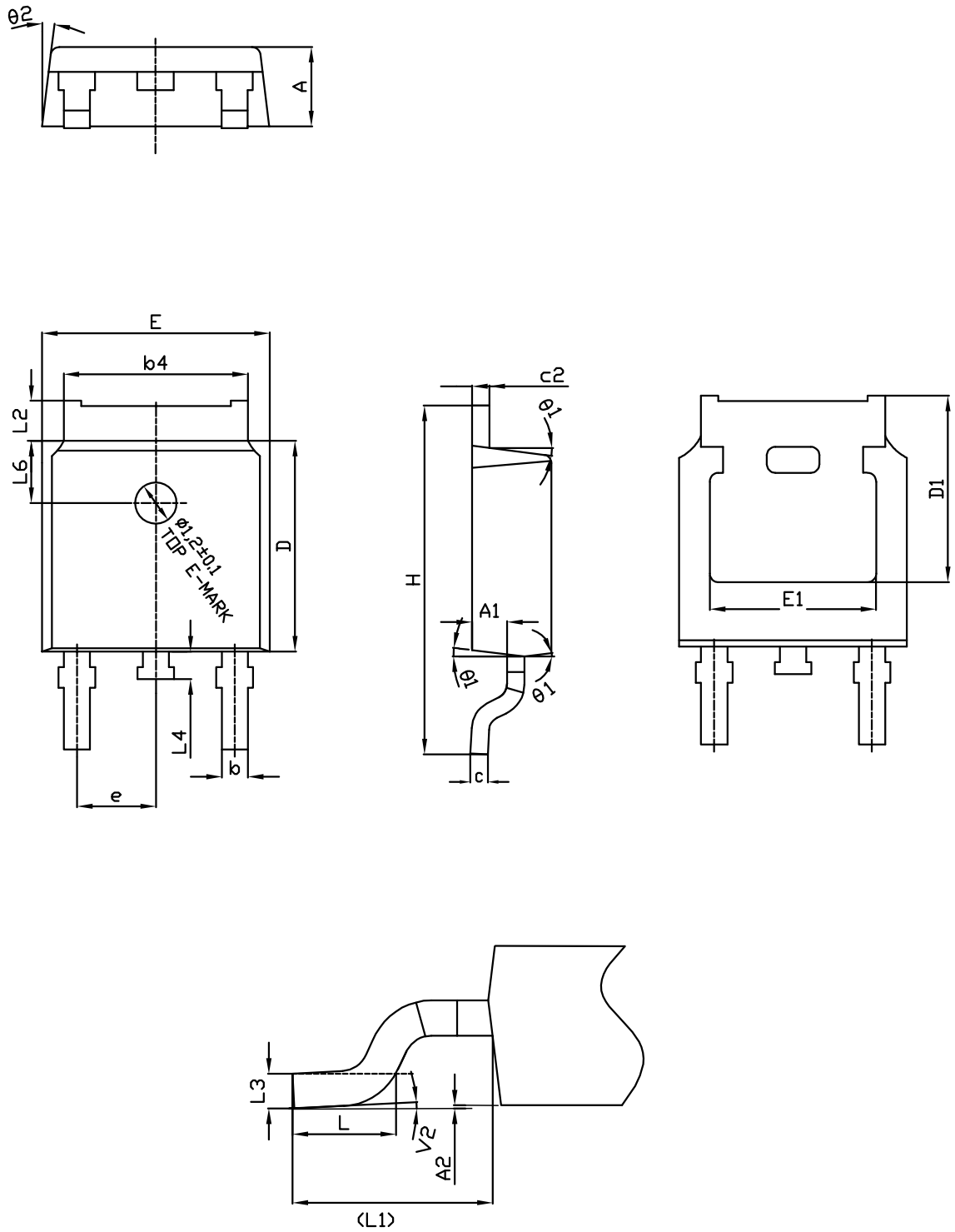
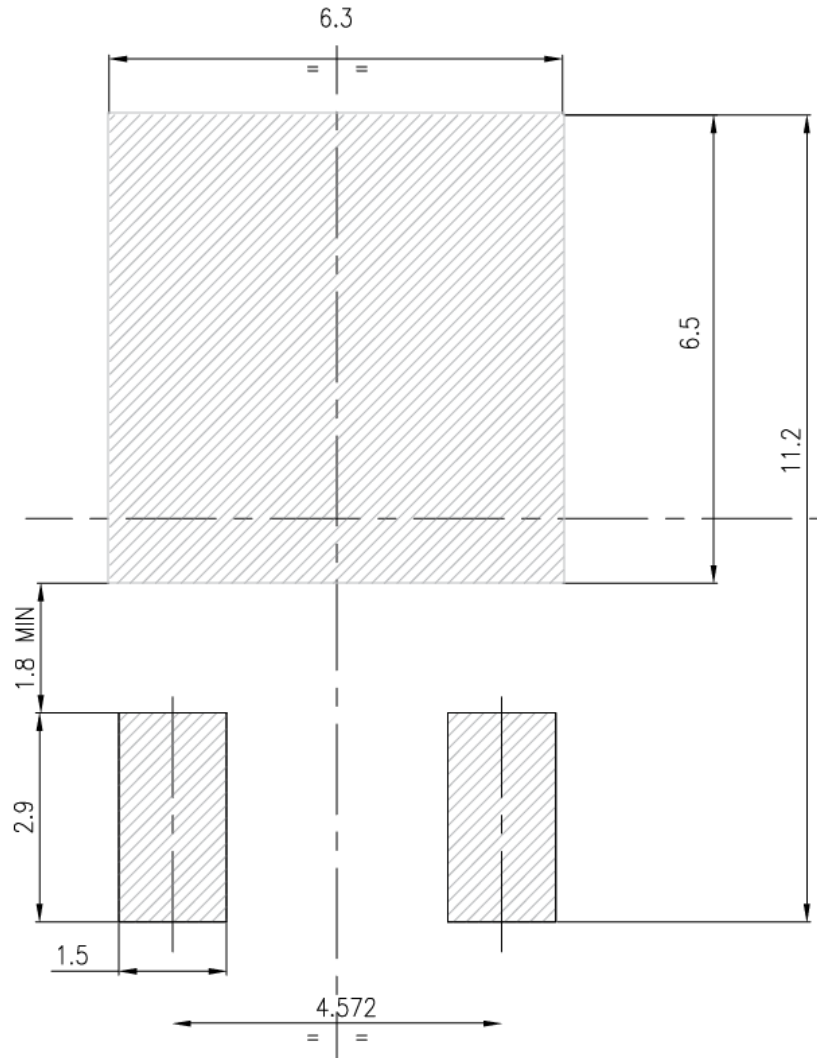

Table 9. DPAK (TO-252) type C2 mechanical data

Dim.	mm		
	Min.	Typ.	Max.
A	2.20	2.30	2.38
A1	0.90	1.01	1.10
A2	0.00		0.10
b	0.72		0.85
b4	5.13	5.33	5.46
c	0.47		0.60
c2	0.47		0.60
D	6.00	6.10	6.20
D1	5.10		5.60
E	6.50	6.60	6.70
E1	5.20		5.50
e	2.186	2.286	2.386
H	9.80	10.10	10.40
L	1.40	1.50	1.70
L1	2.90 REF		
L2	0.90		1.25
L3	0.51 BSC		
L4	0.60	0.80	1.00
L6	1.80 BSC		
θ1	5°	7°	9°
θ2	5°	7°	9°
V2	0°		8°

Figure 23. DPAK (TO-252) recommended footprint (dimensions are in mm)



FP_0068772_rev26

4.3 DPAK (TO-252) packing information

Figure 24. DPAK (TO-252) tape outline

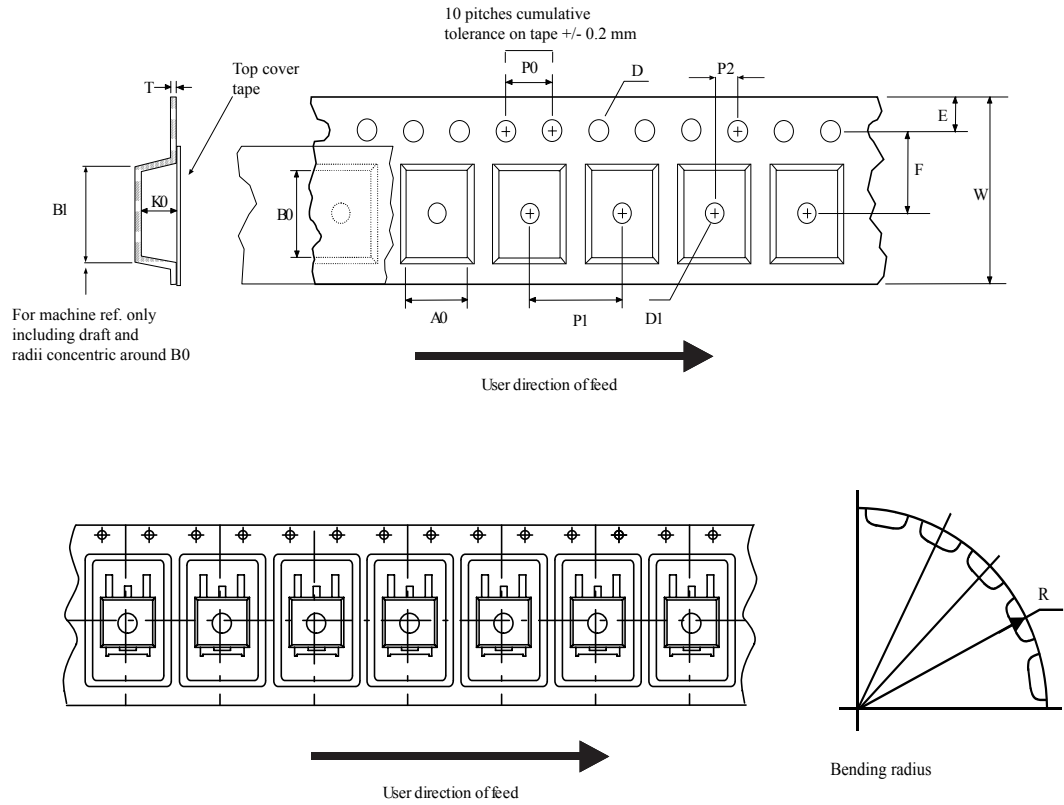

AM08852v1

Figure 25. DPAK (TO-252) reel outline

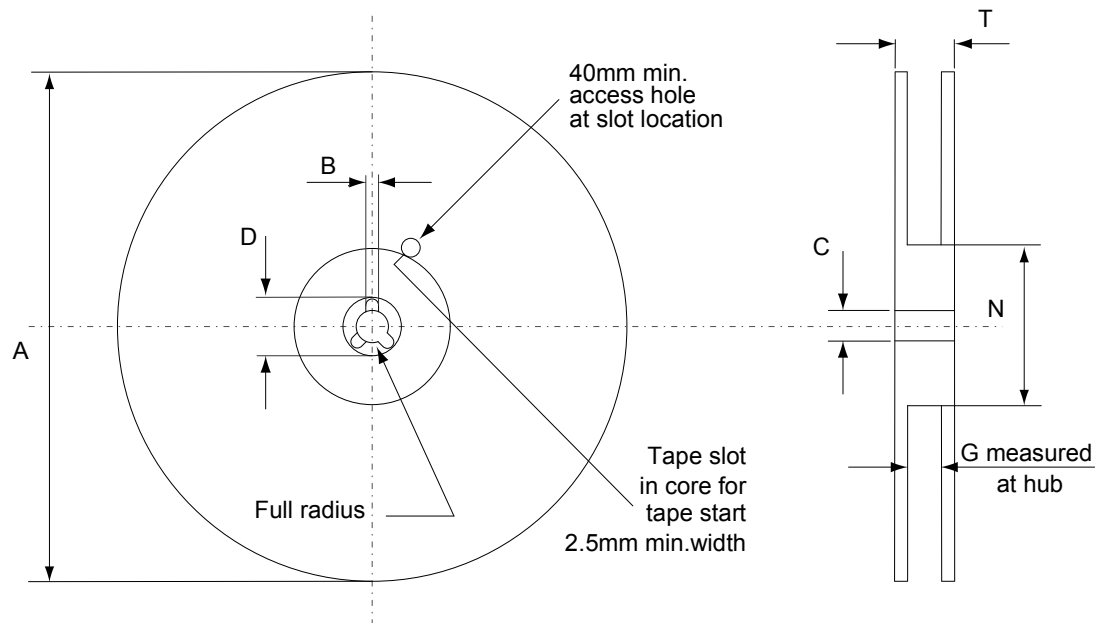

AM06038v1

Table 10. DPAK (TO-252) tape and reel mechanical data

Dim.	Tape		Dim.	Reel	
	mm			mm	
	Min.	Max.		Min.	Max.
A0	6.8	7	A		330
B0	10.4	10.6	B	1.5	
B1		12.1	C	12.8	13.2
D	1.5	1.6	D	20.2	
D1	1.5		G	16.4	18.4
E	1.65	1.85	N	50	
F	7.4	7.6	T		22.4
K0	2.55	2.75			
P0	3.9	4.1		Base qty.	2500
P1	7.9	8.1		Bulk qty.	2500
P2	1.9	2.1			
R	40				
T	0.25	0.35			
W	15.7	16.3			

4.4 TO-220FP package information

Figure 26. TO-220FP package outline

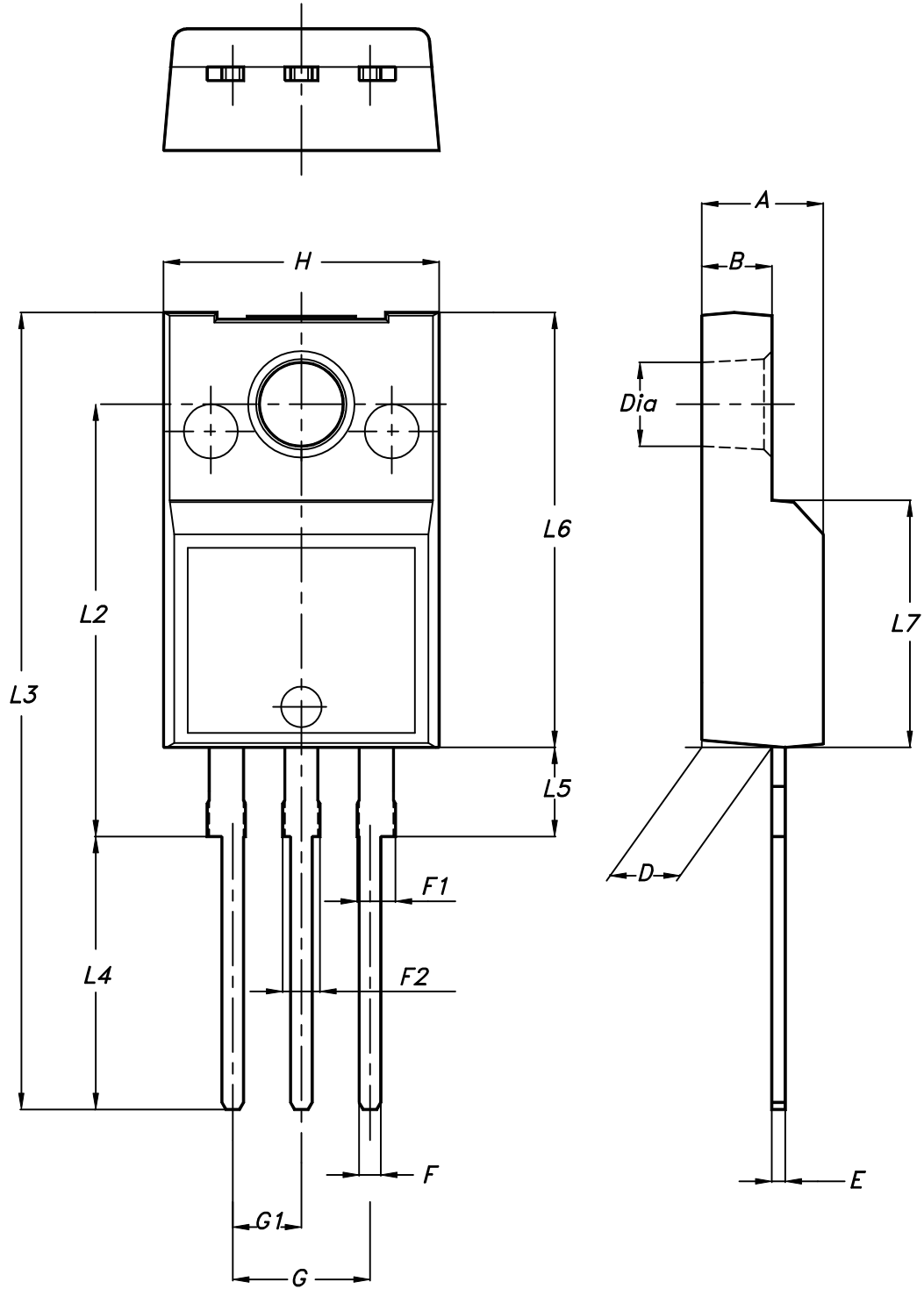

7012510_Rev_12_B

Table 11. TO-220FP package mechanical data

Dim.	mm		
	Min.	Typ.	Max.
A	4.4		4.6
B	2.5		2.7
D	2.5		2.75
E	0.45		0.7
F	0.75		1
F1	1.15		1.70
F2	1.15		1.70
G	4.95		5.2
G1	2.4		2.7
H	10		10.4
L2		16	
L3	28.6		30.6
L4	9.8		10.6
L5	2.9		3.6
L6	15.9		16.4
L7	9		9.3
Dia	3		3.2

5 Ordering information

Table 12. Order codes

Order code	Marking	Package	Packing
STD16NF25	16NF25	DPAK	Tape and reel
STF16NF25		TO-220FP	Tube

Revision history

Table 13. Document revision history

Date	Version	Changes
12-Oct-2007	1	Initial release.
13-Nov-2007	2	Modified: <i>Figure 13: Capacitance variations.</i>
29-Mar-2012	3	<p><i>Figure 2: Safe operating area for TO-220, Figure 4: Safe operating area for TO-220FP and Figure 6: Safe operating area for DPAK</i> have been updated.</p> <p><i>Section 4: Package mechanical data</i> and <i>Section 5: Packaging mechanical data</i> have been updated.</p> <p>Minor text changes</p>
06-Mar-2013	4	<ul style="list-style-type: none"> – Modified: PTOT, derating factor values, <i>note 1</i> on <i>Table 2</i>, Rthj-case, Rthj-amb only for TO-220 and DPAK – Updated: <i>Section 4: Package mechanical data</i> – Minor text changes
21-Jan-2019	5	<p>The part number STP16NF25 has been moved to a separate datasheet.</p> <p>Removed maturity status indication from cover page. The document status is production data.</p> <p>Updated Section 4 Package information.</p> <p>Minor text changes.</p>

Contents

1	Electrical ratings	2
2	Electrical characteristics	3
2.1	Electrical characteristics (curves)	5
3	Test circuits	8
4	Package information	9
4.1	DPAK (TO-252) type A package information	9
4.2	DPAK (TO-252) type C2 package information	11
4.3	DPAK (TO-252) packing information	14
4.4	TO-220FP package information	16
5	Ordering information	19
	Revision history	20

IMPORTANT NOTICE – PLEASE READ CAREFULLY

STMicroelectronics NV and its subsidiaries (“ST”) reserve the right to make changes, corrections, enhancements, modifications, and improvements to ST products and/or to this document at any time without notice. Purchasers should obtain the latest relevant information on ST products before placing orders. ST products are sold pursuant to ST’s terms and conditions of sale in place at the time of order acknowledgement.

Purchasers are solely responsible for the choice, selection, and use of ST products and ST assumes no liability for application assistance or the design of Purchasers’ products.

No license, express or implied, to any intellectual property right is granted by ST herein.

Resale of ST products with provisions different from the information set forth herein shall void any warranty granted by ST for such product.

ST and the ST logo are trademarks of ST. All other product or service names are the property of their respective owners.

Information in this document supersedes and replaces information previously supplied in any prior versions of this document.

© 2019 STMicroelectronics – All rights reserved

Looking for pricing, stock, or lifecycle information?

Click below to explore more details on WIN SOURCE:

- [View 16NF25 on WIN SOURCE](#)
- [STMicroelectronics Information](#)

Optimize Your Supply Chain with WIN SOURCE Solutions

- ✓ Global Sourcing Solution
- ✓ Obsolete Management
- ✓ Cost Control Management
- ✓ Shortage Management
- ✓ Alternative Solution
- ✓ Excess Inventory Management