



**THE DATASHEET OF
VCNL4040M30E-H5**



Fully Integrated Proximity and Ambient Light Sensor With Infrared Emitter, I²C Interface, and Interrupt Function



LINKS TO ADDITIONAL RESOURCES


[3D Models](#)

[Design Tools](#)

[Related Documents](#)

DESCRIPTION

VCNL4040 integrates a proximity sensor (PS), ambient light sensor (ALS), and a high power IRED into one small package. It incorporates photodiodes, amplifiers, and analog to digital converting circuits into a single chip by CMOS process. The 16-bit high resolution ALS offers excellent sensing capabilities with sufficient selections to fulfill most applications whether dark or high transparency lens design. High and low interrupt thresholds can be programmed for both ALS and PS, allowing the component to use a minimal amount of the microcontrollers resources.

The proximity sensor features an intelligent cancellation scheme, so that cross talk phenomenon is eliminated effectively. To accelerate the PS response time, smart persistence prevents the misjudgment of proximity sensing but also keeps a fast response time. In active force mode, a single measurement can be requested, allowing another good approach for more design flexibility to fulfill different kinds of applications with more power saving.

The patented Filtron™ technology achieves ambient light spectral sensitivity closest to real human eye response and offers the best background light cancellation capability (including sunlight) without utilizing the microcontrollers' resources. VCNL4040 provides an excellent temperature compensation capability for keeping output stable under various temperature configurations. ALS and PS functions are easily set via the simple command format of I²C (SMBus compatible) interface protocol. Operating voltage ranges from 2.5 V to 3.6 V. VCNL4040 is packaged in a lead (Pb)-free 8-pin molding package, which offers the best market-proven reliability quality.

FEATURES

- Package type: surface-mount
- Dimensions (L x W x H in mm): 4.0 x 2.0 x 1.1
- Integrated modules: infrared emitter (IRED), ambient light sensor (ALS), proximity sensor (PS), and signal conditioning IC
- Operates ALS and PS in parallel structure
- Filtron™ technology adoption for robust background light cancellation
- Temperature compensation: -40 °C to +85 °C
- Low power consumption I²C (SMBus compatible) interface
- Floor life: 168 h, MSL 3, according to J-STD-020
- Output type: I²C bus (ALS / PS)
- Operation voltage: 2.5 V to 3.6 V
- Material categorization: for definitions of compliance please see www.vishay.com/doc?99912



RoHS
COMPLIANT
HALOGEN
FREE
GREEN
(5-2008)

PROXIMITY FUNCTION

- Immunity to red glow (940 nm IRED)
- Programmable IRED sink current
- Intelligent cancellation to reduce cross talk phenomenon
- Smart persistence scheme to reduce PS response time
- Selectable for 12- / 16-bit PS output data

AMBIENT LIGHT FUNCTION

- High accuracy of ALS ±10 %
- Fluorescent light flicker immunity
- Spectrum close to real human eye responses
- Selectable maximum detection range (819 / 1638 / 3277 / 6553) lux with highest sensitivity 0.0125 lux/step

INTERRUPT

- Programmable interrupt function for ALS and PS with upper and lower thresholds
- Adjustable persistence to prevent false triggers for ALS and PS

APPLICATIONS

- Handheld device
- Notebook, tablet PC
- Consumer device
- Industrial application

**PRODUCT SUMMARY**

PART NUMBER	OPERATING RANGE (mm)	OPERATING VOLTAGE RANGE (V)	I ² C BUS VOLTAGE RANGE (V)	IRE D PULSE CURRENT ⁽¹⁾ (mA)	AMBIENT LIGHT RANGE (lx)	AMBIENT LIGHT RESOLUTION (lx)	OUTPUT CODE	ADC RESOLUTION PROXIMITY / AMBIENT LIGHT
VCNL4040	0 to 200	2.5 to 3.6	1.8 to 3.6	200	0.0125 to 6553	0.0125	16 bit, I ² C	16 bit / 16 bit

Note

⁽¹⁾ Adjustable through I²C interface

ORDERING INFORMATION

ORDERING CODE	PACKAGING	VOLUME ⁽¹⁾	REMARKS
VCNL4040M3OE	Tape and reel	MOQ: 2500 pcs	4.0 mm x 2.0 mm x 1.1 mm
VCNL4040M3OE-H3 ⁽²⁾		MOQ: 1500 pcs	4.34 mm x 2.35 mm x 3.25 mm
VCNL4040M3OE-H5 ⁽²⁾			4.34 mm x 2.35 mm x 3.65 mm

Notes

⁽¹⁾ MOQ: minimum order quantity

⁽²⁾ The interposers are necessary when the component needs to be brought closer to a cover glass and the customers mechanical stack up does not allow for this with the standard height component (VCNL4040M3OE)

ABSOLUTE MAXIMUM RATINGS (T_{amb} = 25 °C, unless otherwise specified)

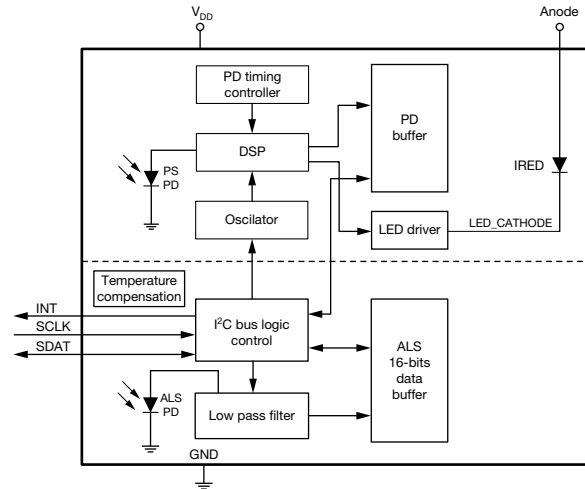
PARAMETER	TEST CONDITION	SYMBOL	MIN.	MAX.	UNIT
Supply voltage		V _{DD}	2.5	3.6	V
Operation temperature range		T _{amb}	-40	+85	°C
Storage temperature range		T _{stg}	-40	+100	°C

RECOMMENDED OPERATING CONDITIONS (T_{amb} = 25 °C, unless otherwise specified)

PARAMETER	TEST CONDITION	SYMBOL	MIN.	MAX.	UNIT
Supply voltage		V _{DD}	2.5	3.6	V
Operation temperature range		T _{amb}	-40	+85	°C
I ² C bus operating frequency		f _(I2CCLK)	10	400	kHz

PIN DESCRIPTIONS

PIN ASSIGNMENT	SYMBOL	TYPE	FUNCTION
1	GND	I	Ground
2	CATHODE	I	Cathode (sensor) connection
3	V _{DD}	I	Power supply input
4	ANODE	I	Anode for IRED
5	CATHODE	I	Cathode (LED) connection
6	INT	O	Interrupt pin
7	SDAT	I / O (open drain)	I ² C data bus data input / output
8	SCLK	I	I ² C digital bus clock input

BLOCK DIAGRAM


BASIC CHARACTERISTICS ($T_{amb} = 25\text{ }^{\circ}\text{C}$, unless otherwise specified)						
PARAMETER	TEST CONDITION	SYMBOL	MIN.	TYP.	MAX.	UNIT
Supply voltage		V_{DD}	2.5		3.6	V
Supply current	Excluded LED driving	I_{DD}		300		μA
	Light condition = dark, $V_{DD} = 3.3\text{ V}$	$I_{DD}(\text{SD})$		0.2		μA
i2C supply voltage		$V_{PULL\ UP}$	1.8		3.6	V
ALS shut down	ALS disable, PS enable	I_{ALSSD}		200		μA
PS shut down	ALS enable, PS disable	I_{PSSD}		260		μA
i2C signal input	Logic high	$V_{DD} = 3.3\text{ V}$	V_{IH}	1.55		V
	Logic low		V_{IL}		0.4	
	Logic high	$V_{DD} = 2.6\text{ V}$	V_{IH}	1.4		V
	Logic low		V_{IL}		0.4	
Peak sensitivity wavelength of ALS		λ_p		550		nm
Peak sensitivity wavelength of PS		λ_{pps}		940		nm
Full ALS counts	16-bit resolution				65 535	steps
Full PS counts	12-bit / 16-bit resolution				4096 / 65 535	steps
ALS sensing tolerance	White LED light source				± 10	%
Detectable intensity	Minimum	$I_T = 640\text{ ms}$, 1 step ⁽¹⁾⁽²⁾		0.0125		lx
	Maximum	$I_T = 80\text{ ms}$, 65 535 step ⁽¹⁾⁽²⁾		6553		
ALS dark offset	$I_T = 80\text{ ms}$, normal sensitivity ⁽¹⁾		0		3	steps
PS detection range	Kodak white card		0		200	mm
Operating temperature range		T_{amb}	-40		+85	$^{\circ}\text{C}$
Cathode (sensor) voltage			2.5		3.6	V
IRED driving current	(3)				200	mA

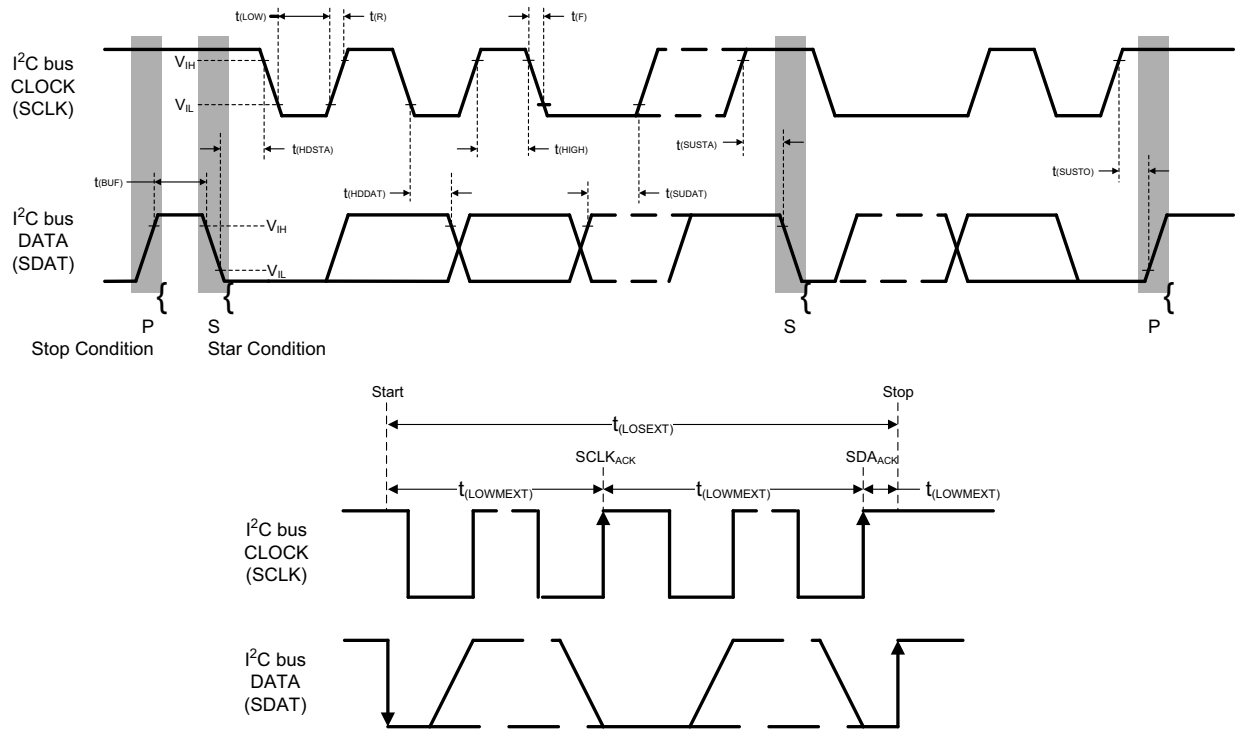
Notes

(1) Test condition: $V_{DD} = 3.3\text{ V}$, temperature: $25\text{ }^{\circ}\text{C}$

(2) Maximum detection range to ambient light can be determined by ALS refresh time adjustment. Refer to table "ALS Resolution and Maximum Detection Range"

(3) Based on IRED on / off duty ratio = 1/40, 1/80, 1/160, and 1/320

I²C BUS TIMING CHARACTERISTICS ($T_{amb} = 25\text{ }^{\circ}\text{C}$, unless otherwise specified)						
PARAMETER	SYMBOL	STANDARD MODE		FAST MODE		UNIT
		MIN.	MAX.	MIN.	MAX.	
Clock frequency	$f_{(SMBCLK)}$	10	100	10	400	kHz
Bus free time between start and stop condition	$t_{(BUF)}$	4.7		1.3		μs
Hold time after (repeated) start condition; after this period, the first clock is generated	$t_{(HDSTA)}$	4.0		0.6		μs
Repeated start condition setup time	$t_{(SUSTA)}$	4.7		0.6		μs
Stop condition setup time	$t_{(SUSTO)}$	4.0		0.6		μs
Data hold time	$t_{(HDDAT)}$		3450		900	ns
Data setup time	$t_{(SUDAT)}$	250		100		ns
I ² C clock (SCK) low period	$t_{(LOW)}$	4.7		1.3		μs
I ² C clock (SCK) high period	$t_{(HIGH)}$	4.0		0.6		μs
Clock / data fall time	$t_{(F)}$		300		300	ns
Clock / data rise time	$t_{(R)}$		1000		300	ns


 Fig. 1 - I²C Bus Timing Diagram

PARAMETER TIMING INFORMATION

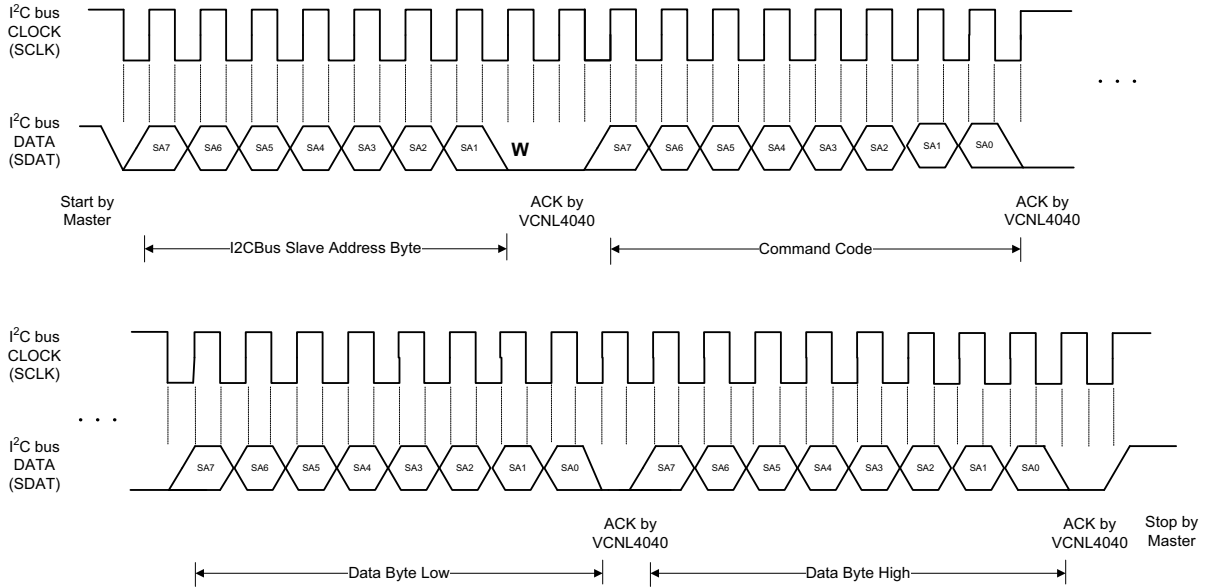


Fig. 2 - I²C Bus Timing for Sending Word Command Format

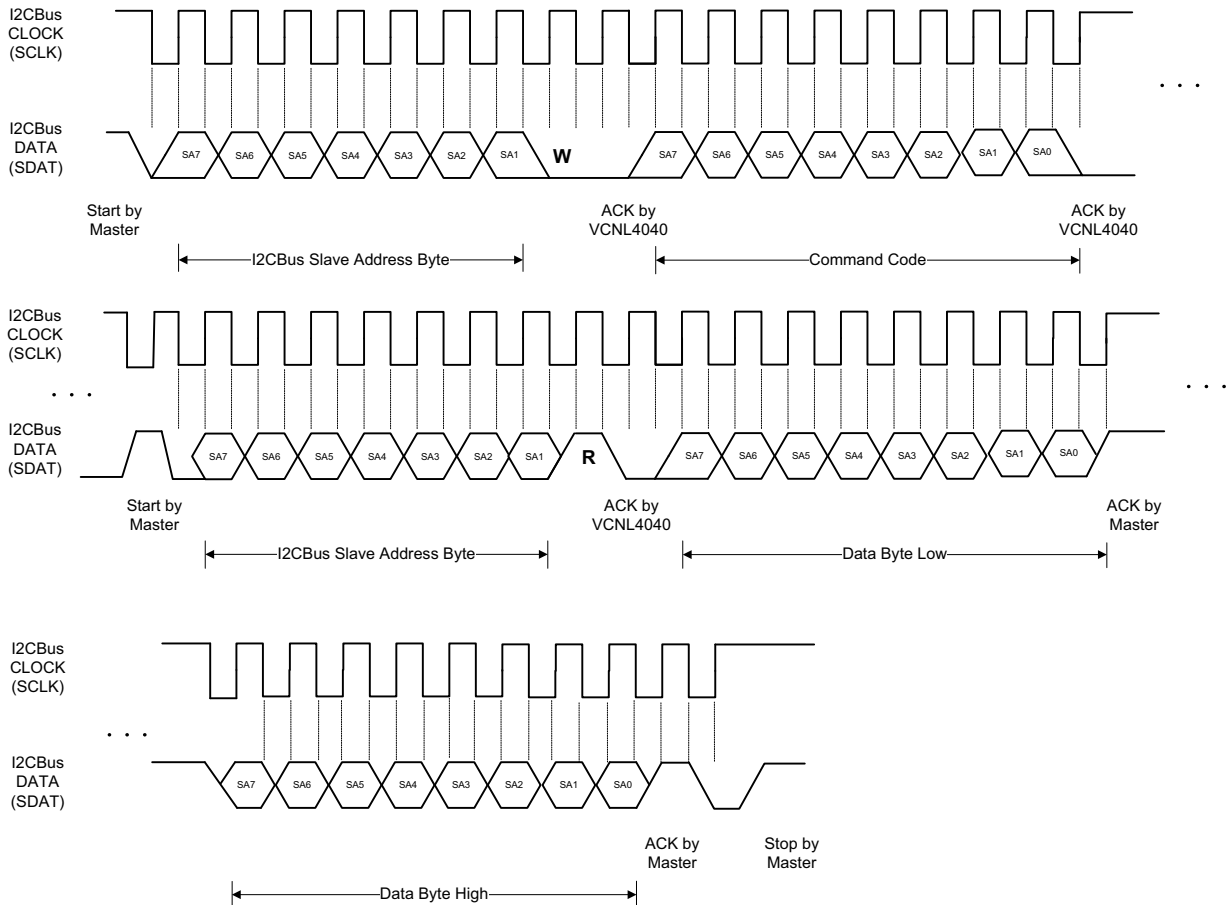


Fig. 3 - I²C Bus Timing for Receiving Word Command Format

TYPICAL PERFORMANCE CHARACTERISTICS ($T_{amb} = 25\text{ }^{\circ}\text{C}$, unless otherwise specified)

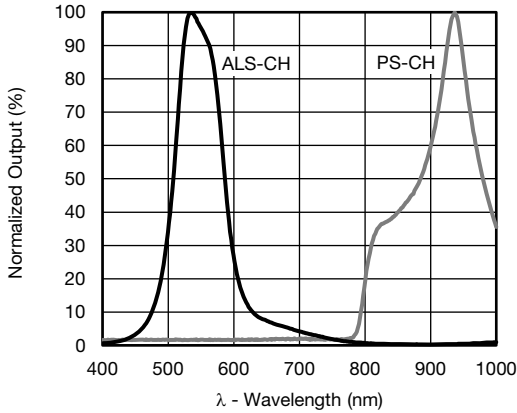


Fig. 4 - Normalized Spectral Response

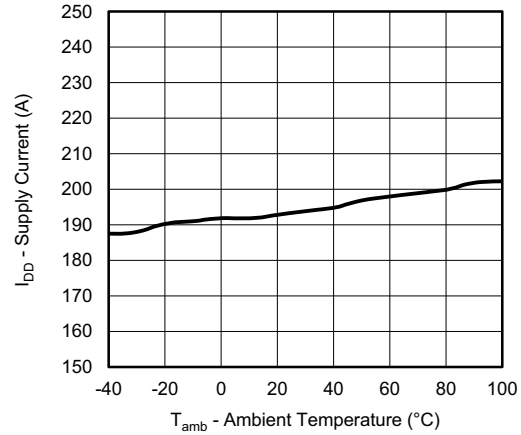


Fig. 7 - I_{DD} vs. Temperature

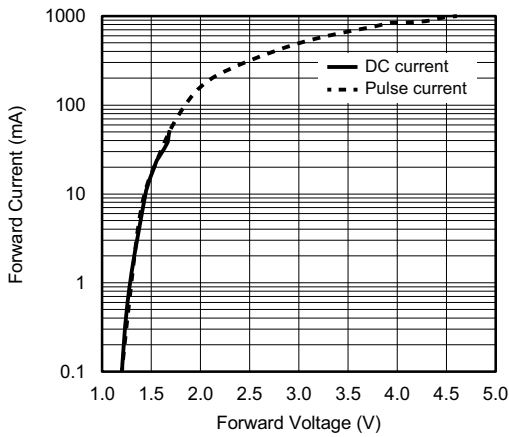


Fig. 5 - Forward Current $I_F = f(V_F)$

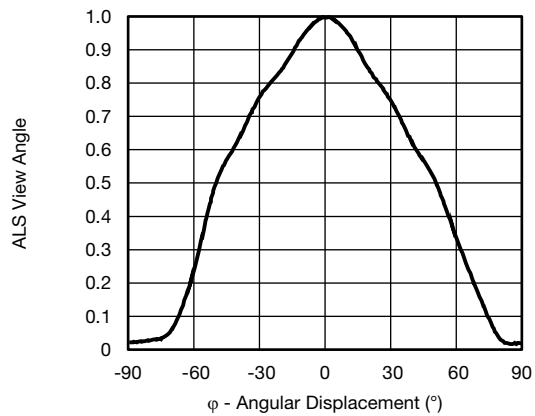


Fig. 8 - ALS View Angle

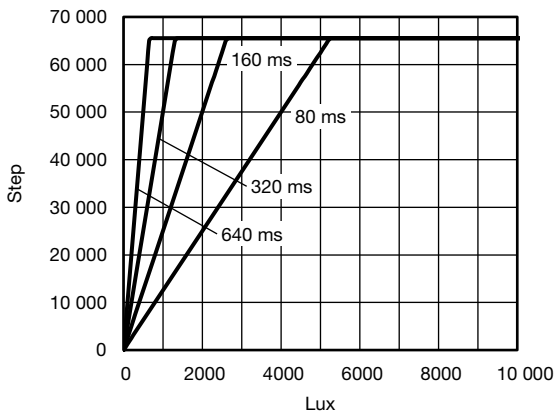


Fig. 6 - ALS Refresh Time vs. Maximum Detection Range

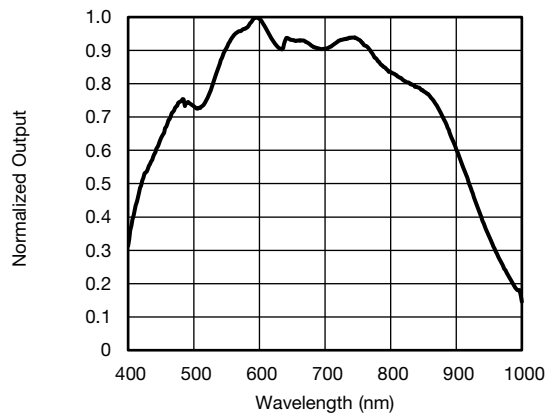


Fig. 9 - White Channel Spectral Response

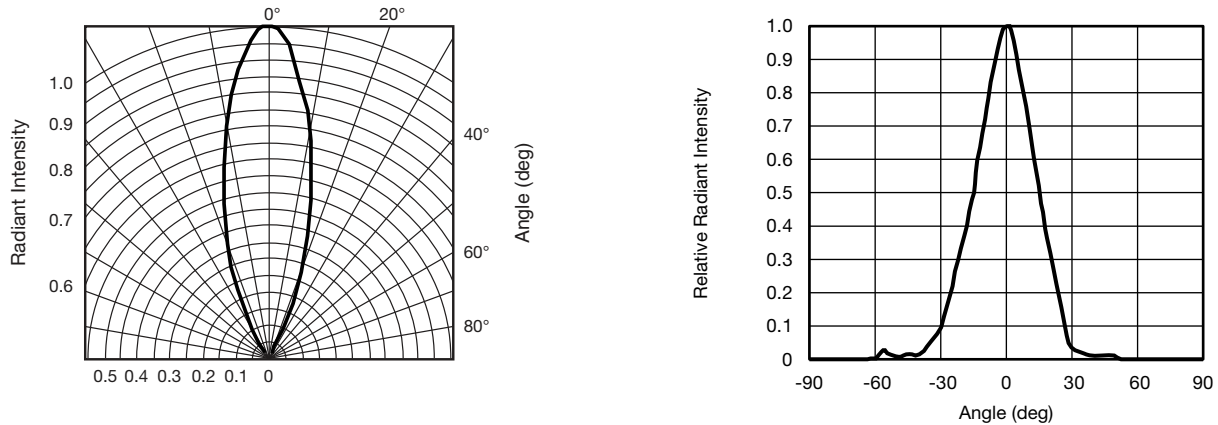


Fig. 10 - IRED Profile

APPLICATION INFORMATION

Pin Connection with the Host

VCNL4040 integrates proximity sensor, ambient light Sensor, and IRED all together with I²C interface. It is very easy for the baseband (CPU) to access PS and ALS output data via I²C interface without extra software algorithms. The hardware schematic is shown in the following diagram.

Two additional capacitors in the circuit can be used for the following purposes: (1) the 0.1 μF capacitor near the V_{DD} pin is used for power supply noise rejection, (2) the 2.2 μF capacitor - connected to the anode - is used to prevent the IRED voltage from instantly dropping when the IRED is turned on, and (3) 2.2 kΩ is suitable for the pull up resistor of I²C except for the 8.2 kΩ applied on the INT pin.

Note

- Cathode (LED) and cathode (sensor): pins need to be connected together externally

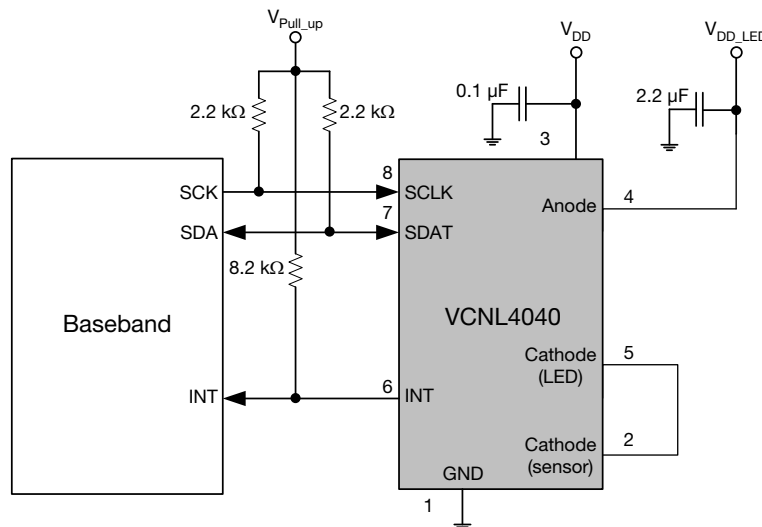


Fig. 11 - Hardware Pin Connection Diagram

Digital Interface

VCNL4040 applies single slave address 0x60 (HEX) of 7-bit addressing following I²C protocol. As figure 12 shows, VCNL4040's I²C command format is simple for read and write operations between VCNL4040 and the host. The white sections indicate host activity and the gray sections indicate VCNL4040's acknowledgement of the host access activity. Write word and read word protocol is suitable for accessing registers particularly for 16-bit data ALS and 12-bit / 16-bit PS data. Interrupt can be cleared by reading data out from register: INT_Flag. All command codes should follow read word and write word protocols.

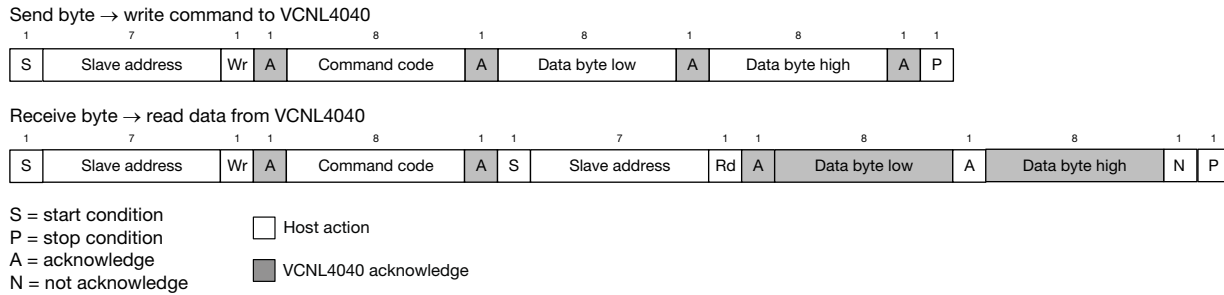


Fig. 12 - Write Word and Read Word Protocol

Function Description

VCNL4040 applies a 16-bit high resolution ALS that provides the best ambient light sensing capability down to 0.01 lux/step which works well under a low transmittance lens design (dark lens). A flexible interrupt function of ALS (register: ALS_CONF) is also supported. The INT signal will not be triggered by VCNL4040 if the ALS value is not over high INT threshold window level, or lower than low INT threshold window level of ALS. VCNL4040 detects different light sources such as fluorescent light, incandescent light, sunlight, and white LED with high accuracy ALS data output after detecting algorithm is implemented.

For proximity sensor function, VCNL4040 supports different kinds of mechanical designs to achieve the best proximity detection performance for any color of object with more flexibility. The basic PS function settings, such as duty ratio, integration time, interrupt, and PS enable / disable, and persistence, are handled by the register: PS_CONF1. Duty ratio controls the PS response time. Integration time represents the duration of the energy being received. The interrupt is triggered when the PS detection levels over the high threshold level setting (register: PS_THDH) or lower than low threshold (register: PS_THDL). If the interrupt function is enabled, the host can react to the interrupt pin, instead of polling the PS data registers. The INT flag (register: INT_Flag) indicates the type of interrupt that has been triggered, depending on the interrupt settings in the configuration registers. PS persistence (PS_PERS) sets up the PS INT trigger conditions, defining the amount of consecutive hits required before an interrupt event occurs. The intelligent cancellation level can be set on register: PS_CANC to reduce the cross talk phenomenon.

VCNL4040 also supports an easy to use proximity detection logic mode, that triggers when the PS high threshold is exceeded and automatically resets the interrupt pin when the proximity reading falls beneath the PS low threshold. This functionality can be set in the register: PS_MS. A smart persistence is provided to be able to prevent false PS interrupt trigger events. Descriptions of each of these parameters are shown in table 1.



TABLE 1 - COMMAND CODE AND REGISTER DESCRIPTION					
COMMAND CODE	DATE BYTE LOW / HIGH	REGISTER NAME	R / W	DEFAULT VALUE	FUNCTION DESCRIPTION
0x00	L	ALS_CONF	R / W	0x01	ALS integration time, persistence, interrupt, and function enable / disable
	H	Reserved	R / W	0x00	Reserved
0x01	L	ALS_THDH_L	R / W	0x00	ALS high interrupt threshold LSB byte
	H	ALS_THDH_M	R / W	0x00	ALS high interrupt threshold MSB byte
0x02	L	ALS_THDL_L	R / W	0x00	ALS low interrupt threshold LSB byte
	H	ALS_THDL_M	R / W	0x00	ALS low interrupt threshold MSB byte
0x03	L	PS_CONF1	R / W	0x01	PS duty ratio, integration time, persistence, and PS enable / disable
	H	PS_CONF2	R / W	0x00	PS output resolution selection, PS interrupt trigger method
0x04	L	PS_CONF3	R / W	0x00	PS multi pulse, active force mode, sunlight immunity setting
	H	PS_MS	R / W	0x00	White channel enable / disable, PS mode selection, PS protection setting, and LED current selection
0x05	L	PS_CANC_L	R / W	0x00	PS cancellation level setting
	H	PS_CANC_M	R / W	0x00	PS cancellation level setting
0x06	L	PS_THDL_L	R / W	0x00	PS low interrupt threshold setting LSB byte
	H	PS_THDL_M	R / W	0x00	PS low interrupt threshold setting MSB byte
0x07	L	PS_THDH_L	R / W	0x00	PS high interrupt threshold setting LSB byte
	H	PS_THDH_M	R / W	0x00	PS high interrupt threshold setting MSB byte
0x08	L	PS_Data_L	R	0x00	PS LSB output data
	H	PS_Data_M	R	0x00	PS MSB output data
0x09	L	ALS_Data_L	R	0x00	ALS LSB output data
	H	ALS_Data_M	R	0x00	ALS MSB output data
0x0A	L	White_Data_L	R	0x00	White LSB output data
	H	White_Data_M	R	0x00	White MSB output data
0x0B	L	Reserved	R	0x00	Reserved
	H	INT_Flag	R	0x00	ALS, PS interrupt flags
0x0C	L	ID_L	R	0x86	Device ID LSB
	H	ID_M	R	0x01	Device ID MSB

Note

- All of reserved register are used for internal test. Please keep as default setting.

Command Register Format

VCNL4040 provides an 8-bit command register for ALS and PS controlling independently. The description of each command format is shown in following tables.

TABLE 2 - REGISTER: ALS_CONF DESCRIPTION									
REGISTER NAME		COMMAND CODE: 0x00_L (0x00 DATA BYTE LOW)							
Command	Bit	7	6	5	4	3	2	1	0
REGISTER: ALS_CONF		COMMAND CODE: 0x00_L (0x00 DATA BYTE LOW)							
Command	Bit	Description							
ALS_IT	7 : 6	(0 : 0) = 80 ms; (0 : 1) = 160 ms; (1 : 0) = 320 ms; (1 : 1) = 640 ms ALS integration time setting, longer integration time has higher sensitivity							
Reserved	5 : 4	Default = (0 : 0)							
ALS_PERS	3 : 2	(0 : 0) = 1, (0 : 1) = 2, (1 : 0) = 4, (1 : 1) = 8 ALS interrupt persistence setting							
ALS_INT_EN	1	0 = ALS interrupt disable, 1 = ALS interrupt enable							
ALS_SD	0	0 = ALS power on, 1 = ALS shut down, default = 1							

**TABLE 3 - REGISTER: 00H_H DESCRIPTION**

REGISTER: Reserved		COMMAND CODE: 0x00_H (0x00 DATA BYTE HIGH)
Command	Bit	Description
Reserved	7 : 0	Default = (0 : 0 : 0 : 0 : 0 : 0 : 0)

TABLE 4 - REGISTER ALS_THDH_L AND ALS_THDH_M DESCRIPTION

		COMMAND CODE: 0x01_L (0x01 DATA BYTE LOW) OR 0x01_H (0x01 DATA BYTE HIGH)
Register	Bit	Description
ALS_THDH_L	7 : 0	0x00 to 0xFF, ALS high interrupt threshold LSB byte
ALS_THDH_M	7 : 0	0x00 to 0xFF, ALS high interrupt threshold MSB byte

TABLE 5 - REGISTER: ALS_THDL_L AND ALS_THDL_M DESCRIPTION

		COMMAND CODE: 0x02_L (0x02 DATA BYTE LOW) AND 0x02_H (0x02 DATA BYTE HIGH)
Register	Bit	Description
ALS_THDL_L	7 : 0	0x00 to 0xFF, ALS low interrupt threshold LSB byte
ALS_THDL_M	7 : 0	0x00 to 0xFF, ALS low interrupt threshold MSB byte

TABLE 6 - REGISTER: PS_CONF1 DESCRIPTION

REGISTER: PS_CONF1		COMMAND CODE: 0x03_L (0x03 DATA BYTE LOW)
Command	Bit	Description
PS_Duty	7 : 6	(0 : 0) = 1/40, (0 : 1) = 1/80, (1 : 0) = 1/160, (1 : 1) = 1/320 PS IRED on / off duty ratio setting
PS_PERS	5 : 4	(0 : 0) = 1, (0 : 1) = 2, (1 : 0) = 3, (1 : 1) = 4 PS interrupt persistence setting
PS_IT	3 : 1	(0 : 0 : 0) = 1T, (0 : 0 : 1) = 1.5T, (0 : 1 : 0) = 2T, (0 : 1 : 1) = 2.5T, (1 : 0 : 0) = 3T, (1 : 0 : 1) = 3.5T, (1 : 1 : 0) = 4T, (1 : 1 : 1) = 8T, PS integration time setting
PS_SD	0	0 = PS power on, 1 = PS shut down, default = 1

TABLE 7 - REGISTER: PS_CONF2 DESCRIPTION

REGISTER: PS_CONF2		COMMAND CODE: 0x03_H (0x03 DATA BYTE HIGH)
Command	Bit	Description
Reserved	7 : 6	(0 : 0), reserved
Reserved	5 : 4	(0 : 0), reserved
PS_HD	3	0 = PS output is 12 bits; 1 = PS output is 16 bits
Reserved	2	Default = 0
PS_INT	1 : 0	(0 : 0) = interrupt disable, (0 : 1) = trigger when close, (1 : 0) = trigger when away, (1 : 1) = trigger when close or away

TABLE 8 - REGISTER: PS_CONF3 DESCRIPTION

REGISTER: PS_CONF3		COMMAND CODE: 0x04_L (0x04 DATA BYTE LOW)
Command	Bit	Description
Reserved	7	0
PS_MPS	6 : 5	Proximity multi pulse numbers (0 : 0) = 1, (0 : 1) = 2, (1 : 0) = 4, (1 : 1) = 8 multi pulses
PS_SMART_PERS	4	0 = disable; 1 = enable PS smart persistence
PS_AF	3	0 = active force mode disable (normal mode), 1 = active force mode enable
PS_TRIG	2	0 = no PS active force mode trigger, 1 = trigger one time cycle VCNL4040 output one cycle data every time host writes in '1' to sensor. The state returns to '0' automatically.
Reserved	1	0
PS_SC_EN	0	PS sunlight cancel enable setting, 1 = sunlight cancellation function enable



TABLE 9 - REGISTER: PS_MS DESCRIPTION		
REGISTER: PS_MS		COMMAND CODE: 0x04_H (0x04 DATA BYTE HIGH)
Command	Bit	Description
White_EN	7	0 = white channel enabled 1 = white channel disabled
PS_MS	6	0 = proximity normal operation with interrupt function 1 = proximity detection logic output mode enable
Reserved	5 : 3	(0 : 0 : 0)
LED_I	2 : 0	(0 : 0 : 0) = 50 mA; (0 : 0 : 1) = 75 mA; (0 : 1 : 0) = 100 mA; (0 : 1 : 1) = 120 mA (1 : 0 : 0) = 140 mA; (1 : 0 : 1) = 160 mA; (1 : 1 : 0) = 180 mA; (1 : 1 : 1) = 200 mA LED current selection setting

TABLE 10 - REGISTER PS_CANC_L AND PS_CANC_M DESCRIPTION		
		COMMAND CODE: 0x05_L (0x05 DATA BYTE LOW) AND 0x05_H(0x05 DATA BYTE HIGH)
Register	Bit	Description
PS_CANC_L	7 : 0	0x00 to 0xFF, PS cancellation level setting_LSB byte
PS_CANC_M	7 : 0	0x00 to 0xFF, PS cancellation level setting_MSB byte

TABLE 11 - REGISTER: PS_THDL_L AND PS_THDL_M DESCRIPTION		
		COMMAND CODE: 0x06_L (0x06 DATA BYTE LOW) AND 0x06_H(0x06 DATA BYTE HIGH)
Register	Bit	Description
PS_THDL_L	7 : 0	0x00 to 0xFF, PS interrupt low threshold setting_LSB byte
PS_THDL_M	7 : 0	0x00 to 0xFF, PS interrupt low threshold setting_MSB byte

TABLE 12 - REGISTER: PS_THDH_L AND PS_THDH_M DESCRIPTION		
		COMMAND CODE: 0x07_L (0x07 DATA BYTE LOW) AND 0x07_H(0x07 DATA BYTE HIGH)
Register	Bit	Description
PS_THDH_L	7 : 0	0x00 to 0xFF, PS interrupt high threshold setting_LSB byte
PS_THDH_M	7 : 0	0x00 to 0xFF, PS interrupt high threshold setting_MSB byte

TABLE 13 - READ OUT REGISTER DESCRIPTION			
Register	Command Code	Bit	Description
PS_Data_L	0x08_L (0x08 data byte low)	7 : 0	0x00 to 0xFF, PS LSB output data
PS_Data_M	0x08_H (0x08 data byte high)	7 : 0	0x00 to 0xFF, PS MSB output data
ALS_Data_L	0x09_L (0x09 data byte low)	7 : 0	0x00 to 0xFF, ALS LSB output data
ALS_Data_M	0x09_H (0x09 data byte high)	7 : 0	0x00 to 0xFF, ALS MSB output data
White_Data_L	0x0A_L (0x0A data byte low)	7 : 0	0x00 to 0xFF, white LSB output data
White_Data_M	0x0A_H (0x0A data byte high)	7 : 0	0x00 to 0xFF, white MSB output data
Reserved	0x0B_L (0x0B data byte low)	7 : 0	Default = 0x00
INT_Flag	0x0B_H (0x0B data byte high)	7 6 5 4 3 2 1 0	Reserved PS_SPFLAG, PS entering protection mode ALS_IF_L, ALS crossing low THD INT trigger event ALS_IF_H, ALS crossing high THD INT trigger event Reserved Reserved PS_IF_CLOSE, PS rises above PS_THDH INT trigger event PS_IF_AWAY, PS drops below PS_THDL INT trigger event
ID_L	0CH_L (0CH data byte low)	7 : 0	86H for MP version sample, device ID LSB byte
ID_M	0CH_H (0CH data byte high)	7 : 6 5 : 4 3 : 0	(0 : 0) (0 : 0) Slave address = 0x60 (7-bit) Version code (0 : 0 : 0 : 1), device ID MSB byte



Adjustable Sampling Time

VCNL4040's LED driver drives the internal IRED with the "LED CATHODE" pin by a pulsed duty cycle. The IRED on / off duty ratio can be set in register: PS_Duty which is related to the current consumption and PS response time. The higher the duty ratio, the faster the response time achieved with higher power consumption. For example, PS_Duty = 1/320, peak IRED current = 100 mA, averaged current consumption is 100 mA/320 = 0.3125 mA.

Initialization

VCNL4040 includes default values for each register. As long as power is on, it is ready to be controlled by host via I2C bus.

Threshold Window Setting

- ALS Threshold Window Setting (Applying ALS INT)

Register: ALS_THDH_L and ALS_THDH_M defines 16-bit ALS high threshold data for LSB byte and MSB byte. Register: ALS_THDL_L and ALS_THDL_M defines 16-bit ALS low threshold data for LSB byte and MSB byte. As long as ALS INT function is enabled, INT will be triggered once the ALS data exceeds ALS_THDH or goes below ALS_THDL. To easily define the threshold range, multiply the value of the resolution (lux/step) by the threshold level (refer to table 14).

TABLE 14 - ALS RESOLUTION AND MAXIMUM DETECTION RANGE				
ALS_IT		SENSITIVITY		MAXIMUM DETECTION RANGE
ALS_IT (7 : 6)	INTEGRATION TIME (typ.)	UNIT (lux/step)	UNIT (lux)	
(0, 0)	80 ms	0.10	6553.5	
(0, 1)	160 ms	0.05	3276.8	
(1, 0)	320 ms	0.025	1638.4	
(1, 1)	640 ms	0.0125	819.2	

- ALS Persistence

The ALS INT is triggered once the ALS value is higher or lower than the threshold window. The ALS_PERS (1, 2, 4, 8 times) parameter, sets the amount of consecutive hits needed, in order for an interrupt event to trigger.
- Programmable PS Threshold

VCNL4040 provides both high and low thresholds setting for PS (register: PS_THDL, PS_THDH).
- PS Persistence

The PS persistence function (PS_PERS, 1, 2, 3, 4) helps to avoid false trigger of the PS INT. It defines the amount of consecutive hits needed in order for a PS interrupt event to be triggered.
- PS Active Force mode

An extreme power saving way to use PS is to apply PS active force (register: PS_CONF3 command: PS_AF = 1) mode. Anytime host would like to request one proximity measurement, write a '1' into register: PS_CONF3 command: PS_Trig. This triggers a single PS measurement, which can be read from the PS result registers. VCNL4040 stays in standby mode constantly.

Data Access

All of VCNL4040 16 bit command registers are readable. The result data for ALS, white, and PS measurements can be read out from their respective registers. Each result is made of 2 bytes.

TABLE 15 - 16-BIT ALS DATA FORMAT																
VCNL4040																
Bit	15	14	13	12	11	10	9	8	7	6	5	4	3	2	1	0
Register	ALS_DataM								ALS_DataL							

Intelligent Cancellation

VCNL4040 provides an intelligent cancellation method to reduce cross talk phenomenon for the proximity sensor. The output data will be subtracted by the value set in register: PS_CANC.

Interruption (INT)

The VCNL4040 has an interrupt feature for both the PS and ALS channel. The purpose of the interrupt feature is to actively inform the host once INT has been triggered. When the interrupt is enabled, the host does not need to continuously read the data registers of the sensor, but instead can simply react to the interrupt pin. As long as the host enables ALS interrupt (register: ALS_INT_EN) or PS interrupt (register: PS_INT) function, the level of INT pin (pin 6) is pulled low once an interrupt event has been triggered. All registers are accessible even if INT is triggered.

ALS INT is triggered when ALS value crosses over the value set in register: ALS_THDH or below the value set by register: ALS_THDL. PS INT is triggered when the PS value crosses over the value set in register: PS_THDH or falls below the value set in register: PS_THDL. Which of these thresholds to react to, can be set by the PS_INT bits in the register: PS_CONF2.

Interruption Flag

Register: INT_Flag represents all of the interrupt trigger statuses for ALS and PS. If any of these flags trigger from “0” to “1”, the INT pin will be pulled low. Once the host reads INT_Flag register, all the flags are cleared (reset to “0”), and the INT pin is reset to high.

PROXIMITY DETECTION LOGIC OUTPUT MODE

VCNL4040 has a proximity detection logic mode, enabling the host to read the state of PS (near or far) simply by monitoring the INT pin (pin 6). When this mode is selected, the INT pin is pulled low when an object is close to the sensor (value is above high threshold) and is reset to high when the object moves away (value is below low threshold). Register: PS_THDH / PS_THDL define where these threshold levels are set.

It should be noted that whenever the proximity detection logic mode has been enabled, the INT pin only reacts to proximity interrupt events. If the host would like to use ALS INT function, the bit PS_MS in the register: PS_MS needs to be set to normal operation mode (PS_MS = 0). In order for the proximity detection logic mode to function, one of the PS_INT bits in register: PS_CONF2 must be enabled (“trigger when close”, “trigger when away”, or “trigger when close or away”). If PS_INT is set to “INT Disable” the proximity detection logic mode will not function.

PROXIMITY DETECTION HYSTERESIS

A hysteresis is created by setting the low and high threshold values. With proximity detection logic mode disabled, an interrupt event will trigger and stay triggered until it is cleared in the INT_Flag register. The register is cleared automatically once it is read. If the interrupt flags are not cleared after an interrupt event has occurred, the VCNL4040 will not react to another interrupt event until the INT-Flag register has been cleared. An example of this could be when turning on and off a backlight of a mobile display. First the PS INT triggers when the PS value is over PS_THDH. The host switches off the panel backlight and then clears INT. When PS value is less than PS_THDL, host switches on panel backlight.

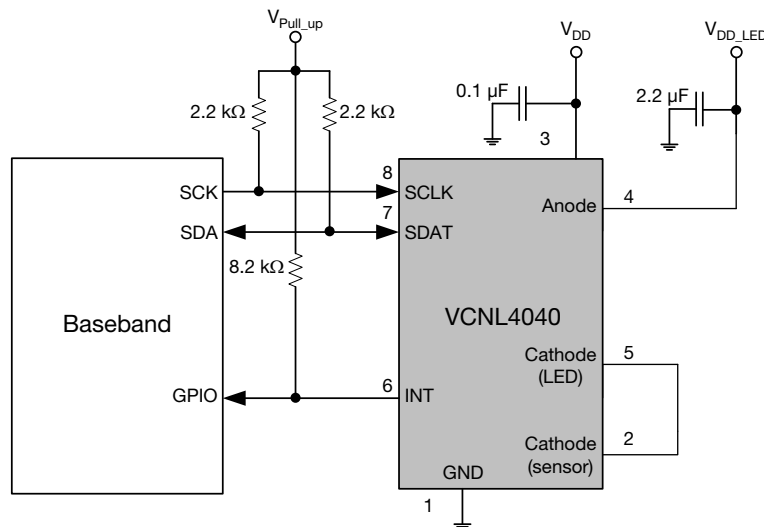
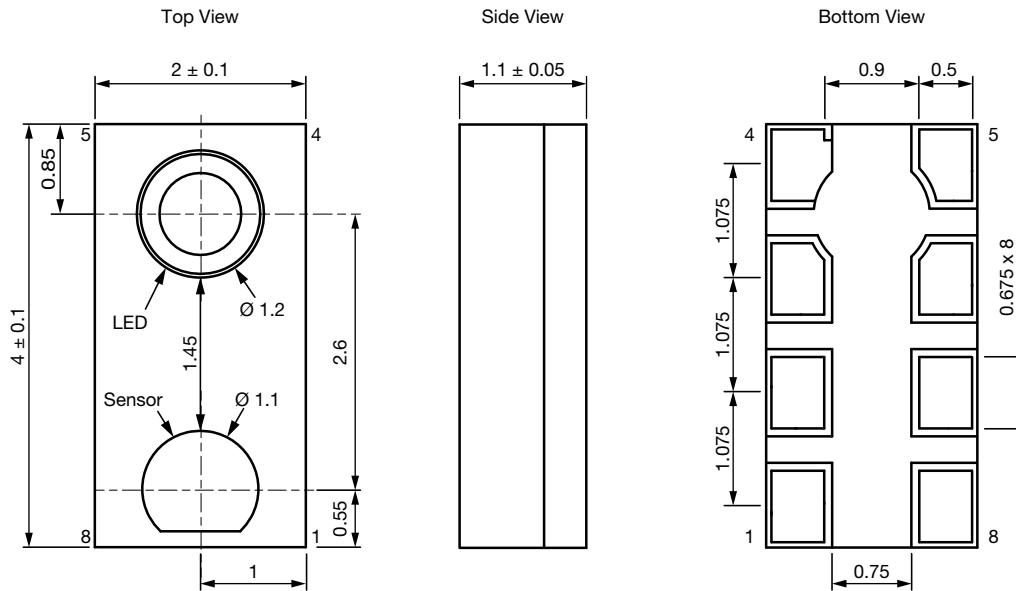


Fig. 13 - VCNL4040 Reference Circuit Connection with Host (Proximity Detection Logic Output Mode)
(VCNL4040 INT pin connecting to BB GPIO instead of INT pin)

PACKAGE INFORMATION (VCNL4040M3OE) in millimeters


1	GND	5	Cathode (LED)
2	Cathode (sensor)	6	INT
3	V _{DD}	7	SDAT
4	Anode	8	SCLK

Fig. 14 - VCNL4040 Package Dimensions

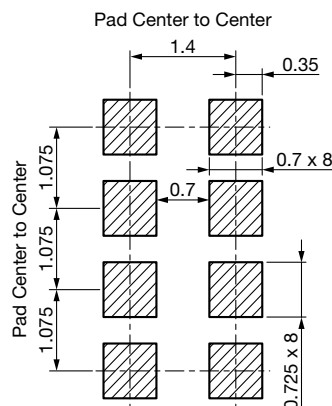
LAYOUT PAD INFORMATION (VCNL4040M3OE) in millimeters


Fig. 15 - VCNL4040M3OE PCB Layout Footprint

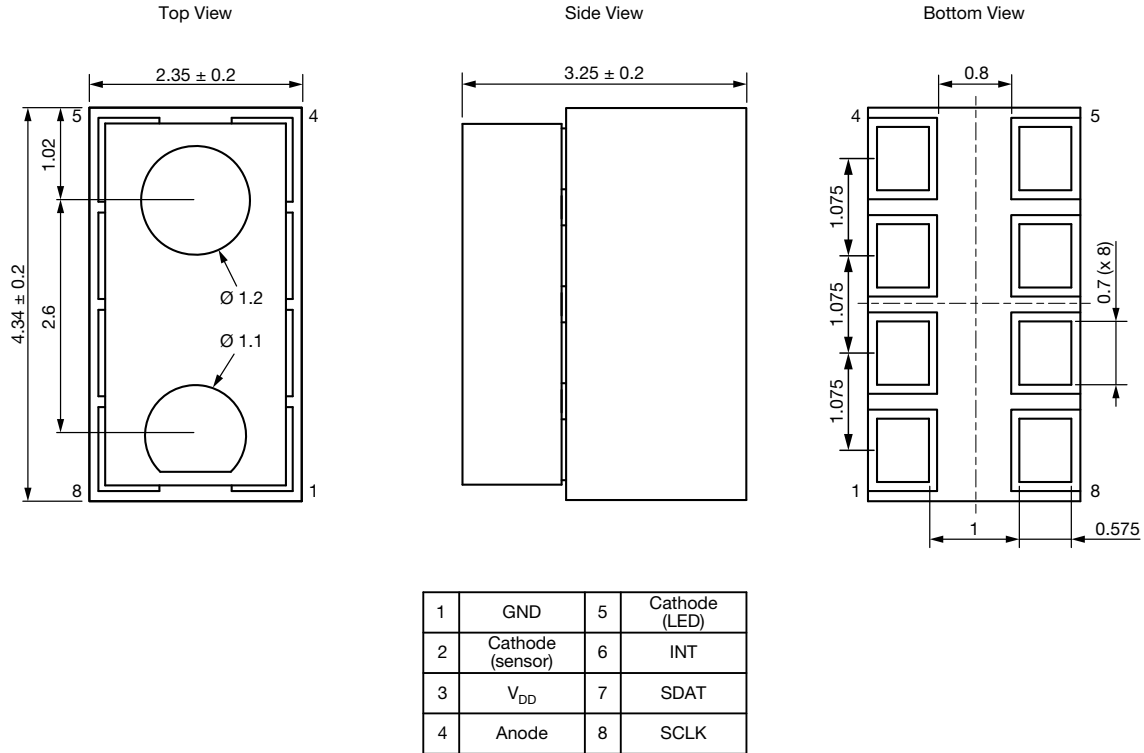
PACKAGE INFORMATION (VCNL4040M3OE-H3) in millimeters


Fig. 16 - VCNL4040M3OE-H3 Package Dimensions

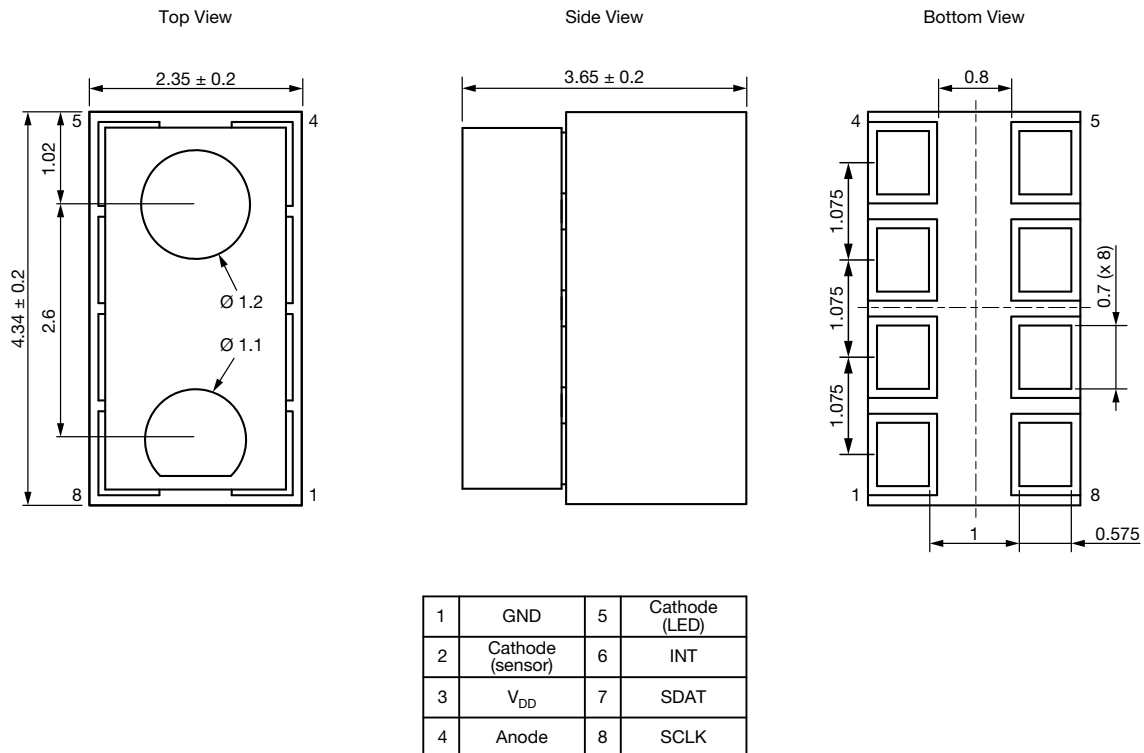
PACKAGE INFORMATION (VCNL4040M3OE-H5) in millimeters


Fig. 17 - VCNL4040M3OE-H5 Package Dimensions

LAYOUT PAD INFORMATION (VCNL4040M3OE-H3, VCNL4040M3OE-H5) in millimeters

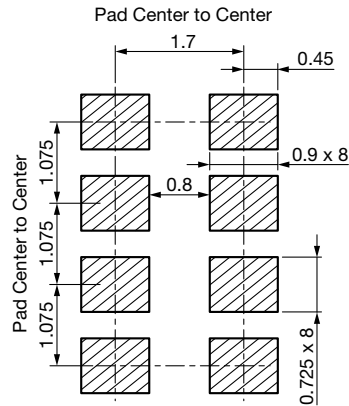


Fig. 18 - VCNL4040M3OE-H3 and H5 PCB Layout Footprint

APPLICATION CIRCUIT BLOCK REFERENCE

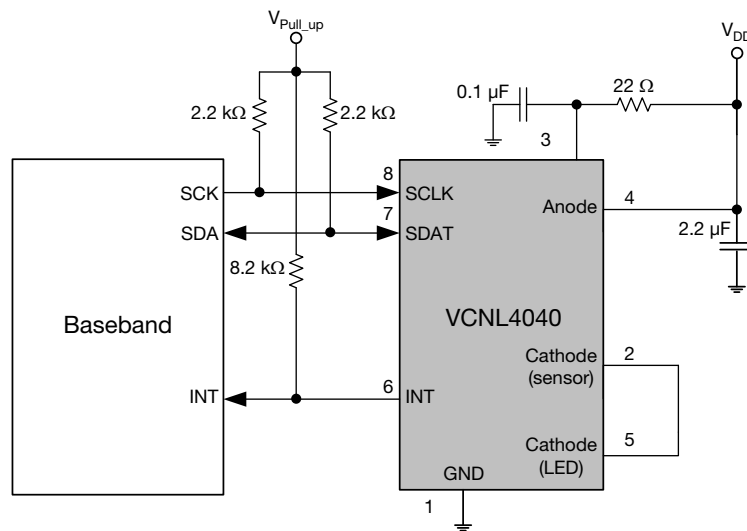


Fig. 19 - VCNL4040 Application Circuit (V_{DD} (sensor and LED) suggestion circuit)



RECOMMENDED STORAGE AND REBAKING CONDITIONS				
PARAMETER	CONDITIONS	MIN.	MAX.	UNIT
Storage temperature		5	50	°C
Relative humidity			60	%
Open time			168	h
Total time	From the date code on the aluminized envelope (unopened)		12	months
Rebaking	Tape and Reel: 60 °C		22	h
	Tube: 60 °C		22	h

RECOMMENDED INFRARED REFLOW

Soldering conditions which are based on J-STD-020 C

IR REFLOW PROFILE CONDITION			
PARAMETER	CONDITIONS	TEMPERATURE	TIME
Peak temperature		260 °C + 5 °C / - 5 °C (max.: 265 °C)	10 s
Preheat temperature range and timing		150 °C to 200 °C	60 s to 180 s
Timing within 5 °C to peak temperature			10 s to 30 s
Timing maintained above temperature / time		217 °C	60 s to 150 s
Timing from 25 °C to peak temperature			8 minutes (max.)
Ramp-up rate		3 °C/s (max.)	
Ramp-down rate		6 °C/s (max.)	

Recommend Normal Solder Reflow is 235 °C to 265 °C

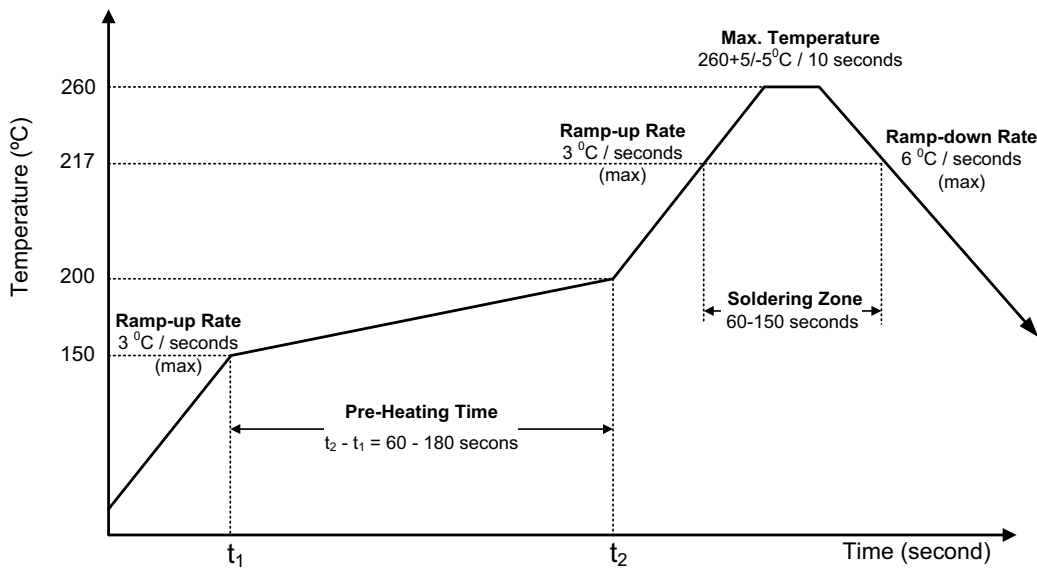
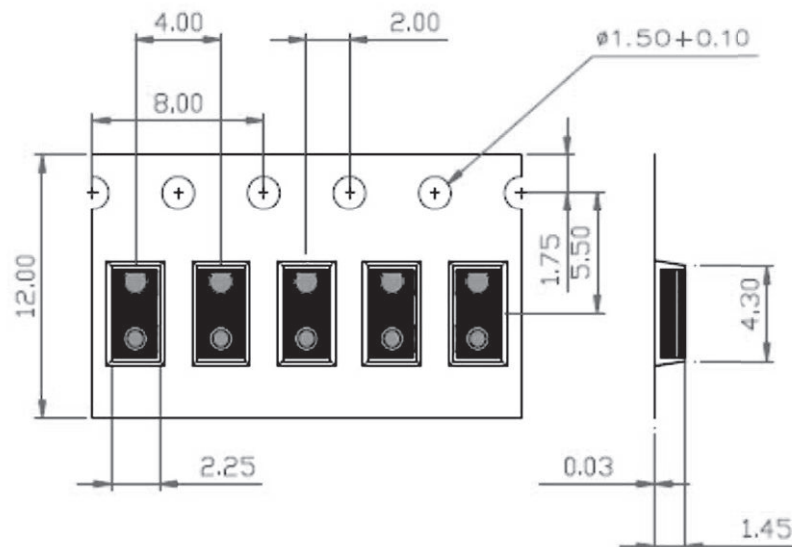
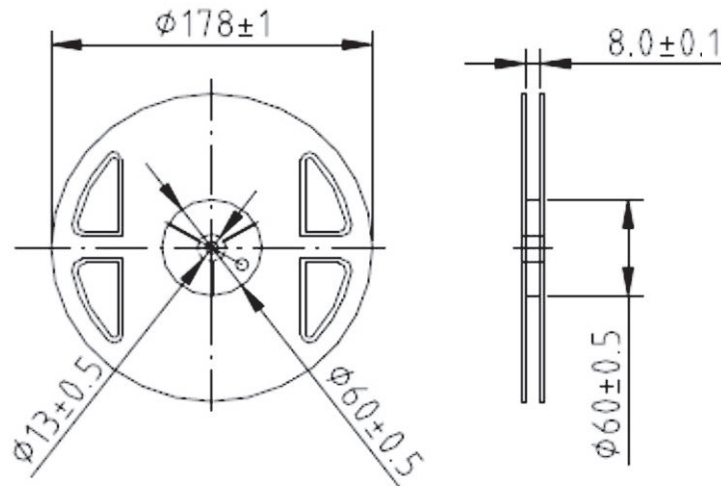


Fig. 20 - VCNL4040 Solder Reflow Profile Chart

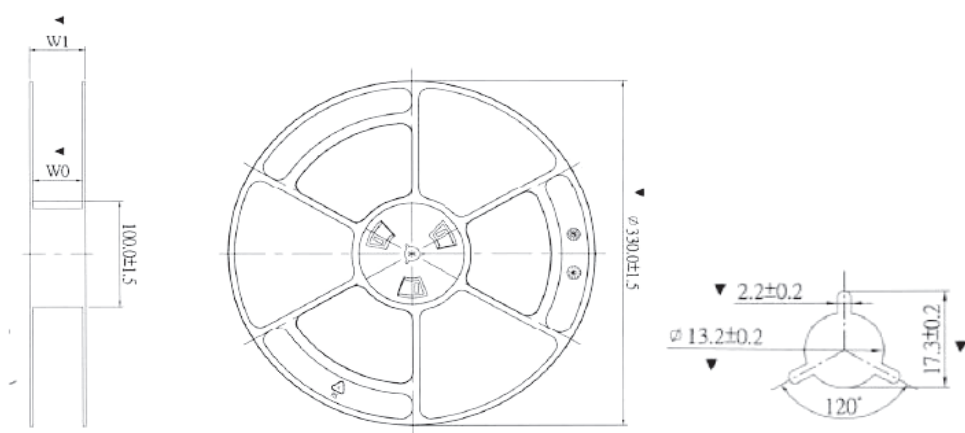
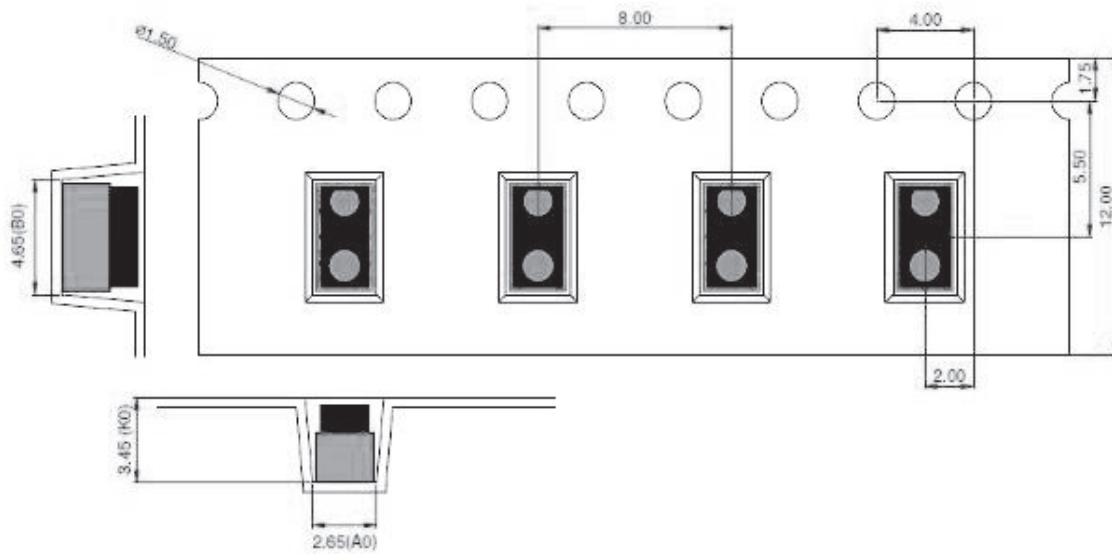
RECOMMENDED IRON TIP SOLDERING CONDITION AND WARNING HANDLING

1. Solder the device with the following conditions:
 - 1.1.Soldering temperature: 400 °C (max.)
 - 1.2.Soldering time: 3 s (max.)
2. If the temperature of the method portion rises in addition to the residual stress between the leads, the possibility that an open or short circuit occurs due to the deformation or destruction of the resin increases.
3. The following methods: VPS and wave soldering, have not been suggested for the component assembly.
4. Cleaning method conditions:
 - 4.1. Solvent: methyl alcohol, ethyl alcohol, isopropyl alcohol
 - 4.2.Solvent temperature < 45 °C (max.)
 - 4.3.Time: 3 minutes (min.)

TAPE PACKAGING INFORMATION in millimeters


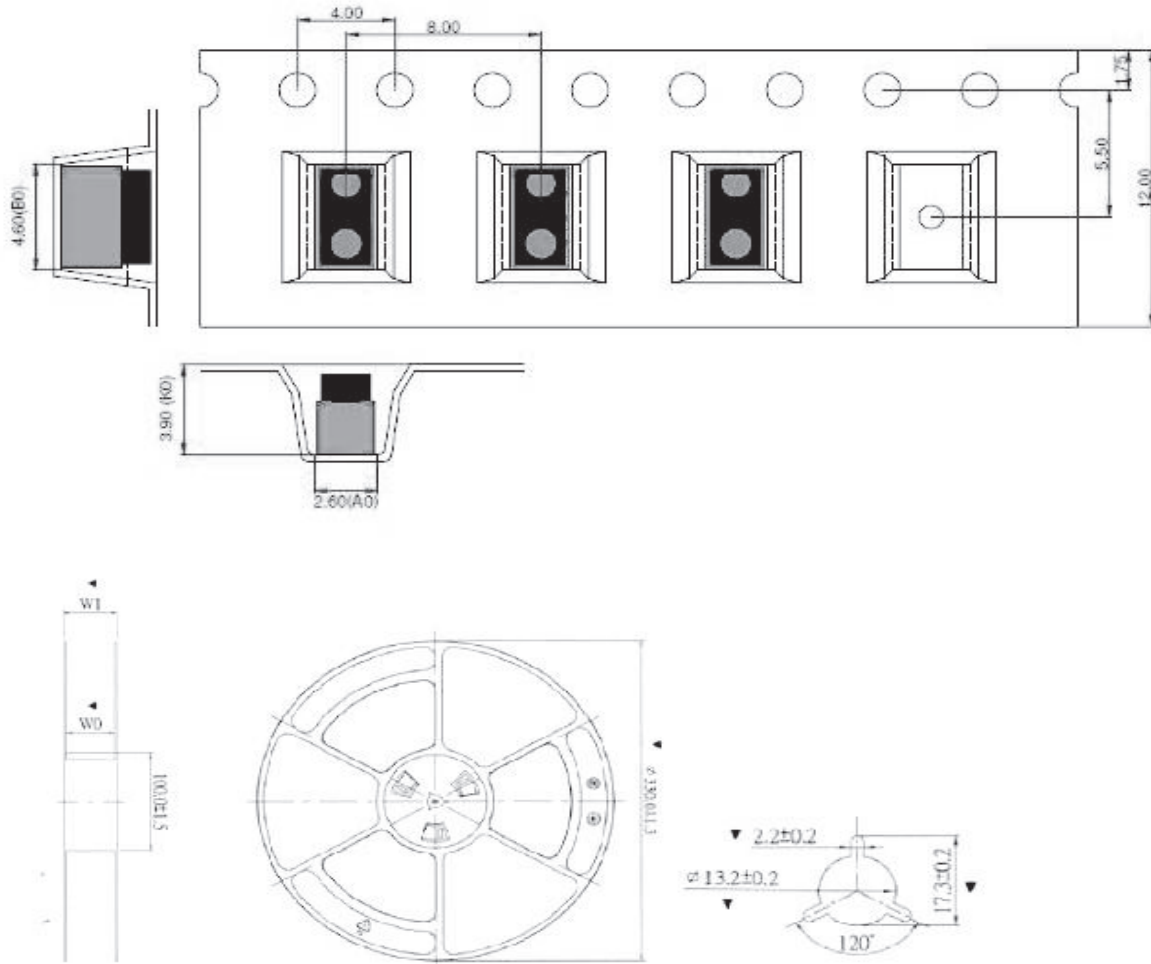


TAPE PACKAGING INFORMATION (VCNL4040M30E-H3) in millimeters



W0 : 12.6 +/- 0.5 mm W1 : 20.6 +/- 0.5mm
 Tolerance: ± 0.1 (unit=mm)
 Quantity: 1500 pcs/Reel

TAPE PACKAGING INFORMATION (VCNL4040M30E-H5) in millimeters



W0 : 12.6 +/- 0.5 mm W1 : 20.6 +/- 0.5mm
 Tolerance ±0.1(unit=mm)
 Quantity: 1500pcs/Reel



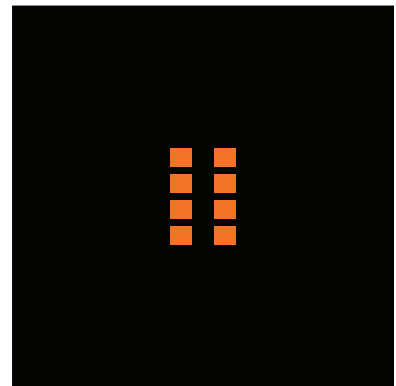
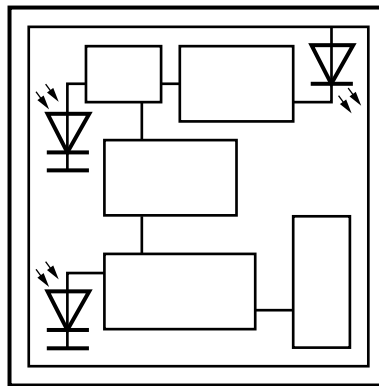
Footprint and Schematic Information for VCNL4040

The footprint and schematic symbols for the following parts can be accessed using the link to the SnapEDA website. They are available in Eagle, Altium, KiCad, OrCAD / Allegro, Pulsonix, and PADS.

Note that the 3D models for these parts can be found on the Vishay product page. The links are included here for convenience.

PART NUMBER	FOOTPRINT / SCHEMATIC	3D MODEL
VCNL4040-M30E-H3	www.snapeda.com/parts/VCNL4040M30E-H3/Vishay/view-part/	-
VCNL4040-M30E-H5	www.snapeda.com/parts/VCNL4040M30E-H5/Vishay/view-part/	-
VCNL4040-M30E	www.snapeda.com/parts/VCNL4040M30E/Vishay/view-part/	www.vishay.com/doc?84352

For technical issues and product support, please contact sensorstechsupport@vishay.com.





Disclaimer

ALL PRODUCT, PRODUCT SPECIFICATIONS AND DATA ARE SUBJECT TO CHANGE WITHOUT NOTICE TO IMPROVE RELIABILITY, FUNCTION OR DESIGN OR OTHERWISE.

Vishay Intertechnology, Inc., its affiliates, agents, and employees, and all persons acting on its or their behalf (collectively, "Vishay"), disclaim any and all liability for any errors, inaccuracies or incompleteness contained in any datasheet or in any other disclosure relating to any product.

Vishay makes no warranty, representation or guarantee regarding the suitability of the products for any particular purpose or the continuing production of any product. To the maximum extent permitted by applicable law, Vishay disclaims (i) any and all liability arising out of the application or use of any product, (ii) any and all liability, including without limitation special, consequential or incidental damages, and (iii) any and all implied warranties, including warranties of fitness for particular purpose, non-infringement and merchantability.

Statements regarding the suitability of products for certain types of applications are based on Vishay's knowledge of typical requirements that are often placed on Vishay products in generic applications. Such statements are not binding statements about the suitability of products for a particular application. It is the customer's responsibility to validate that a particular product with the properties described in the product specification is suitable for use in a particular application. Parameters provided in datasheets and / or specifications may vary in different applications and performance may vary over time. All operating parameters, including typical parameters, must be validated for each customer application by the customer's technical experts. Product specifications do not expand or otherwise modify Vishay's terms and conditions of purchase, including but not limited to the warranty expressed therein.

Hyperlinks included in this datasheet may direct users to third-party websites. These links are provided as a convenience and for informational purposes only. Inclusion of these hyperlinks does not constitute an endorsement or an approval by Vishay of any of the products, services or opinions of the corporation, organization or individual associated with the third-party website. Vishay disclaims any and all liability and bears no responsibility for the accuracy, legality or content of the third-party website or for that of subsequent links.

Vishay products are not designed for use in life-saving or life-sustaining applications or any application in which the failure of the Vishay product could result in personal injury or death unless specifically qualified in writing by Vishay. Customers using or selling Vishay products not expressly indicated for use in such applications do so at their own risk. Please contact authorized Vishay personnel to obtain written terms and conditions regarding products designed for such applications.

No license, express or implied, by estoppel or otherwise, to any intellectual property rights is granted by this document or by any conduct of Vishay. Product names and markings noted herein may be trademarks of their respective owners.

Looking for pricing, stock, or lifecycle information?

Click below to explore more details on WIN SOURCE:

 [View VCNL4040M3OE-H5 on WIN SOURCE](#)

 [Vishay Information](#)

Optimize Your Supply Chain with WIN SOURCE Solutions

-  Global Sourcing Solution
-  Obsolete Management
-  Cost Control Management
-  Shortage Management
-  Alternative Solution
-  Excess Inventory Management