



**THE DATASHEET OF
TPS61033DRLR**



TPS61033X 5.5-V 5.5-A 2.4-MHz Fully-Integrated Synchronous Boost Converter, with Output Discharge Function

1 Features

- Input voltage range: 1.8 V to 5.5 V
- Output voltage range: 2.2 V to 5.5 V(TPS61033)
 - FB connects to VIN output voltage for fixed 5.0 V(TPS61033X)
- Two valley switching current limit options
 - TPS61033: 5.5-A typical
 - TPS610333: 1.85-A typical
- High efficiency and power capability
 - Two 25-mΩ (LS) / 46-mΩ (HS) MOSFETs
 - Support up to 2.4 MHz with small L-C
 - Up to 93.42% efficiency at $V_{IN} = 3.3V$, $V_{OUT} = 5V$, and $I_{OUT} = 1A$
 - Up to 90.78% efficiency at $V_{IN} = 3.3V$, $V_{OUT} = 5V$, and $I_{OUT} = 2A$
- Extend the system operating time
 - Typical 20-μA quiescent current into V_{IN} pin
 - Typical 5.3μA quiescent current into V_{OUT} pin
 - Typical 0.1-μA shutdown current
- ±1.5% Reference voltage accuracy over –40°C to +125°C
- Power good output with window comparator
- Pin-selectable auto PFM or forced PWM mode at light load
- Pass-through mode when $V_{IN} > V_{OUT}$
- Safety and robust operation features
 - True disconnection between input and output during shutdown
 - Output overvoltage and thermal shutdown protections
 - Output short-circuit protection
- 2.1-mm × 1.6-mm SOT583 8-Pin package

2 Applications

- [Tablet\(multimedia\)](#)
- [Smart speaker](#)
- [Mobile POS](#)

3 Description

The TPS61033X is a synchronous boost converter. The device provides a power supply solution for portable equipment and smart devices powered by various batteries and other power supply. The TPS61033 has 5.5-A (typical) valley switch current limit and TPS610333 has 1.85-A (typical) valley switch current limit over full temperature range.

The TPS61033X uses adaptive constant on-time valley-current-control topology to regulate the output voltage and operates at 2.4-MHz switching frequency. There are two optional modes at light load by configuring the MODE pin: auto PFM mode and forced PWM to balance the efficiency and noise immunity in light load. The TPS61033X consumes a 20-μA quiescent current from V_{IN} at light load condition. During shutdown, the TPS61033X is completely disconnected from the input power and only consumes a 0.1-μA current to achieve long battery life. The TPS61033X has 5.75-V output overvoltage protection, output short circuit protection, and thermal shutdown protection.

The TPS61033X offers a very small solution size with 2.1-mm × 1.6-mm SOT583 package and minimum amount of external components.

Device Information

PART NUMBER	PACKAGE ⁽¹⁾	BODY SIZE (NOM)
TPS61033X	SOT583 (8)	2.10 mm × 1.20 mm

(1) For all available packages, see the orderable addendum at the end of the data sheet.

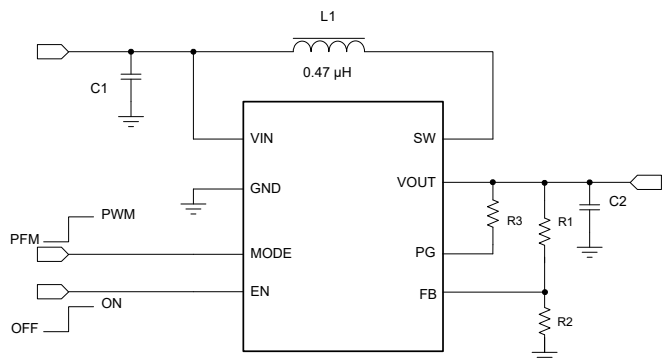

Typical Application Circuit



4 Device Comparison Table

Table 4-1. Device comparison table

PART NUMBER	Valley Switch Current Limit (typ)	Output Voltage (typ)	Spread Spectrum
TPS61033	5.5 A	2.2 V ~5.5 V	NO
TPS610333	1.85 A	Fixed 5 V	NO

Table of Contents

1 Features	1	8.3 Feature Description.....	11
2 Applications	1	8.4 Device Functional Modes.....	14
3 Description	1	9 Application and Implementation	16
4 Device Comparison Table	2	9.1 Application Information.....	16
5 Revision History	3	9.2 Typical Application.....	16
6 Pin Configuration and Functions	4	9.3 Power Supply Recommendations.....	20
7 Specifications	5	9.4 Layout.....	20
7.1 Absolute Maximum Ratings.....	5	10 Device and Documentation Support	23
7.2 ESD Ratings.....	5	10.1 Device Support.....	23
7.3 Recommended Operating Conditions.....	5	10.2 Receiving Notification of Documentation Updates..	23
7.4 Thermal Information.....	5	10.3 Support Resources.....	23
7.5 Electrical Characteristics.....	6	10.4 Trademarks.....	23
7.6 Typical Characteristics.....	8	10.5 Electrostatic Discharge Caution.....	23
8 Detailed Description	10	10.6 Glossary.....	23
8.1 Overview.....	10	11 Mechanical, Packaging, and Orderable Information	23
8.2 Functional Block Diagram.....	10		

5 Revision History

NOTE: Page numbers for previous revisions may differ from page numbers in the current version.

Changes from Revision C (August 2023) to Revision D (September 2023)	Page
• Corrected TPS610333 Specification limits.....	6
Changes from Revision B (March 2023) to Revision C (August 2023)	Page
• Added TPS610333 device.....	1
Changes from Revision A (March 2023) to Revision B (June 2023)	Page
• Changed unit in Figure 7-7 to μA	8
• Changed 80 mA to 800 mA in Figure 9-6	19
Changes from Revision * (October 2022) to Revision A (March 2023)	Page
• Changed the device status from Advance Information to Production Data.....	1

6 Pin Configuration and Functions

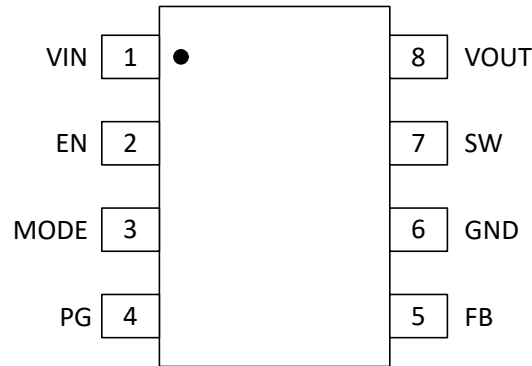

Figure 6-1. DRL Package 8-Pin SOT583 Top View

Table 6-1. Pin Functions

PIN		I/O	DESCRIPTION
NO.	NAME		
1	VIN	I	IC power supply input
2	EN	I	Enable logic input. Logic high voltage enables the device. Logic low voltage disables the device and turns it into shutdown mode.
3	MODE	I	Operation mode selection in the light load condition. When it is connected to logic high voltage, the device works in forced PWM mode. When it is connected to logic low voltage, the device works in auto PFM mode.
4	PG	O	Power good indicator and open drain output
5	FB	I	TPS61033: Voltage feedback of adjustable output voltage, when FB connect to VIN, output voltage is fixed 5.0V TPS610333: Should be connected with VIN for fixed 5.0 V output voltage.
6	GND	PWR	Ground pin of the IC
7	SW	PWR	The switch pin of the converter. It is connected to the drain of the internal low-side power MOSFET and the source of the internal high-side power MOSFET.
8	VOUT	PWR	Boost converter output

7 Specifications

7.1 Absolute Maximum Ratings

over operating free-air temperature range (unless otherwise noted)⁽¹⁾

		MIN	MAX	UNIT
Voltage range at terminals ⁽²⁾	VIN, EN, FB, SW, VOUT	-0.3	7	V
	SW spike at 10ns	-0.7	8	V
	SW spike at 1ns	-0.7	9	V
Operating junction temperature, T _J		-40	150	°C
Storage temperature, T _{stg}		-65	150	°C

- (1) Operation outside the *Absolute Maximum Ratings* may cause permanent device damage. *Absolute Maximum Ratings* do not imply functional operation of the device at these or any other conditions beyond those listed under *Recommended Operating Conditions*. If used outside the *Recommended Operating Conditions* but within the *Absolute Maximum Ratings*, the device may not be fully functional, and this may affect device reliability, functionality, performance, and shorten the device lifetime.
- (2) All voltage values are with respect to network ground terminal.

7.2 ESD Ratings

			VALUE	UNIT
V _(ESD)	Electrostatic discharge	Human-body model (HBM), per ANSI/ESDA/JEDEC JS-001 ⁽¹⁾	±2000	V
		Charged-device model (CDM), per JEDEC specification JESD22-C101 ⁽²⁾	±750	

- (1) JEDEC document JEP155 states that 500-V HBM allows safe manufacturing with a standard ESD control process. Manufacturing with less than 500-V HBM is possible with the necessary precautions. Pins listed as ±2000 V may actually have higher performance.
- (2) JEDEC document JEP157 states that 250-V CDM allows safe manufacturing with a standard ESD control process. Manufacturing with less than 250-V CDM is possible with the necessary precautions. Pins listed as ±500 V may actually have higher performance.

7.3 Recommended Operating Conditions

over operating free-air temperature range (unless otherwise noted)

		MIN	NOM	MAX	UNIT	
V _{IN}	Input voltage range	1.8		5.5	V	
V _{OUT}	Output voltage setting range	2.2		5.5	V	
L	Effective inductance range	0.33	0.47	1.3	μH	
C _{IN}	Effective input capacitance range	1.0	4.7		μF	
C _{OUT}	Effective output capacitance range	I _{OUT} ≤ 1A	4	10	1000	μF
		I _{OUT} > 1A	10	20	1000	μF
T _J	Operating junction temperature	-40		125	°C	

7.4 Thermal Information

THERMAL METRIC ⁽¹⁾		TPS61033	TPS61033	UNIT
		DRL (SOT583)- 8 PINS	DRL (SOT583)- 8 PINS	
		Standard	EVM ⁽²⁾	
R _{θJA}	Junction-to-ambient thermal resistance	117.5	65.8	°C/W
R _{θJC}	Junction-to-case thermal resistance	40.0	NA	°C/W
R _{θJB}	Junction-to-board thermal resistance	23.0	NA	°C/W
Ψ _{JT}	Junction-to-top characterization parameter	2.8	1.0	°C/W
Ψ _{JB}	Junction-to-board characterization parameter	22.9	28.4	°C/W

- (1) For more information about traditional and new thermal metrics, see the [Semiconductor and IC Package Thermal Metrics](#) application report.
- (2) Measured on TPS61033EVM, 4-layer, 2oz copper NA PCB.

7.5 Electrical Characteristics

$T_J = -40^{\circ}\text{C}$ to 125°C , $V_{IN} = 3.6\text{ V}$ and $V_{OUT} = 5.0\text{ V}$. Typical values are at $T_J = 25^{\circ}\text{C}$ (unless otherwise noted)

PARAMETER		TEST CONDITIONS	MIN	TYP	MAX	UNIT
POWER SUPPLY						
V_{IN}	Input voltage range		1.8		5.5	V
V_{IN_UVLO}	Under-voltage lockout threshold	V_{IN} rising		1.7	1.79	V
		V_{IN} falling		1.6		V
V_{IN_HYS}	VIN UVLO hysteresis			65		mV
I_Q	Quiescent current into VIN pin	IC enabled, No load, No switching $V_{IN} = 1.8\text{ V}$ to 5.5 V , $V_{FB} = V_{REF} + 0.1\text{ V}$, T_J up to 125°C	13	20	25	μA
	Quiescent current into VOUT pin	IC enabled, No load, No switching $V_{OUT} = 2.2\text{ V}$ to 5.5 V , $V_{FB} = V_{REF} + 0.1\text{ V}$, T_J up to 125°C		5.3	9	μA
I_{SD}	Shutdown current into VIN and SW pin	IC disabled, $V_{IN} = V_{SW} = 3.6\text{ V}$, $T_J = 25^{\circ}\text{C}$		0.1	0.2	μA
OUTPUT						
V_{OUT}	Output voltage setting range		2.2		5.5	V
V_{OUT} (fixed 5V)	Fixed output voltage	FB connected to VIN $V_{IN} < V_{OUT}$, PWM mode	4.93	5	5.07	V
V_{REF}	Reference voltage at the FB pin	PWM mode	591	600	609	mV
V_{REF}	Reference voltage at the FB pin	PFM mode		606		mV
V_{OVP}	Output over-voltage protection threshold	V_{OUT} rising	5.5	5.75	6.0	V
V_{OVP_HYS}	Over-voltage protection hysteresis			0.11		V
I_{FB_LKG}	Leakage current at FB pin	$T_J = 25^{\circ}\text{C}$		4	25	nA
I_{FB_LKG}	Leakage current at FB pin	$T_J = 125^{\circ}\text{C}$		5	30	nA
I_{VOUT_LKG}	Leakage current into VOUT pin	IC disabled, $V_{IN} = 0\text{ V}$, $V_{SW} = 0\text{ V}$, $V_{OUT} = 5.5\text{ V}$, $T_J = 25^{\circ}\text{C}$		0.2	0.5	μA
t_{ss}	Soft startup time	Internal SS ramp time		0.86		ms
POWER SWITCH						
$R_{DS(on)}$	High-side MOSFET on resistance	$V_{OUT} = 5.0\text{ V}$		46		m Ω
$R_{DS(on)}$	Low-side MOSFET on resistance	$V_{OUT} = 5.0\text{ V}$		25		m Ω
f_{SW}	Switching frequency	$V_{IN} = 3.6\text{ V}$, $V_{OUT} = 5.0\text{ V}$, PWM mode	2.0	2.4	2.8	MHz
t_{ON_min}	Minimum on time		20	48	65	ns
t_{OFF_min}	Minimum off time			35	70	ns
I_{LIM_SW}	Valley current limit	$V_{IN} = 3.6\text{ V}$, $V_{OUT} = 5.0\text{ V}$ TPS61033	4.7	5.5	6.1	A
I_{LIM_SW}	Valley current limit	$V_{IN} = 3.6\text{ V}$, $V_{OUT} = 5.0\text{ V}$ TPS610333	1.55	1.85	2.25	A
$I_{REVERSE}$	Reverse current limit (MODE=1)	$V_{IN} = 3.6\text{ V}$, $V_{OUT} = 5.0\text{ V}$; MODE = 1		-1.4		A
I_{LIM_CHG}	Pre-charge current	$V_{IN} = 1.8 - 5.5\text{ V}$, $V_{OUT} < 0.4\text{ V}$		330		mA
$I_{LIM_CHG_max}$	Maximum pre-charge current	$V_{IN} = 2.4\text{ V}$, $V_{OUT} > 0.4\text{ V}$; TPS610333		800	1100	mA
LOGIC INTERFACE						
V_{EN_H}	EN logic high threshold	$V_{IN} > 1.8\text{ V}$ or $V_{OUT} > 2.2\text{ V}$			1.2	V
V_{EN_L}	EN logic low threshold	$V_{IN} > 1.8\text{ V}$ or $V_{OUT} > 2.2\text{ V}$	0.4			V
V_{MODE_H}	MODE Logic high threshold	$V_{IN} > 1.8\text{ V}$ or $V_{OUT} > 2.2\text{ V}$			1.2	V
V_{MODE_L}	MODE Logic Low threshold	$V_{IN} > 1.8\text{ V}$ or $V_{OUT} > 2.2\text{ V}$	0.4			V
R_{DOWN}	EN pins internal pull-down resistor			10		M Ω
R_{DOWN}	MODE pins internal pull-down resistor			1		M Ω
POWER GOOD						
PGD_{OV}	PGOOD upper threshold	% of VOUT setting	105	107	110	%
PGD_{UV}	PGOOD lower threshold	% of VOUT setting	91	93	95	%
PGD_{HYST}	PGOOD upper threshold (rising&falling)	% of VOUT setting		2.5		%
$t_{PGDFLT(rise)}$	Delay time to PGOOD high signal			1.3		ms
$t_{PGDFLT(fall)}$	Glitch filter time of PGOOD			33		μs
PROTECTION						
T_{SD}	Thermal shutdown threshold	T_J rising		170		$^{\circ}\text{C}$

$T_J = -40^{\circ}\text{C}$ to 125°C , $V_{IN} = 3.6\text{ V}$ and $V_{OUT} = 5.0\text{ V}$. Typical values are at $T_J = 25^{\circ}\text{C}$ (unless otherwise noted)

PARAMETER		TEST CONDITIONS	MIN	TYP	MAX	UNIT
T_{SD}	Thermal shutdown threshold	T_J falling		155		$^{\circ}\text{C}$
T_{SD_HYS}	Thermal shutdown hysteresis	T_J falling below T_{SD}		15		$^{\circ}\text{C}$

7.6 Typical Characteristics

$V_{IN} = 3.6\text{ V}$, $V_{OUT} = 5\text{ V}$, $T_J = 25^\circ\text{C}$, unless otherwise noted

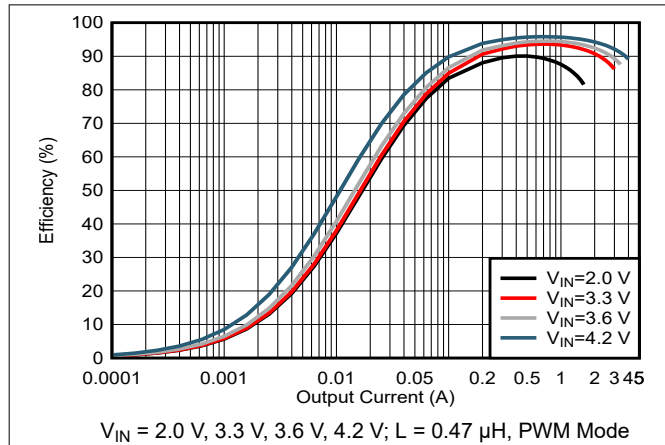

Figure 7-1. Efficiency vs Output Current $V_{OUT} = 5\text{ V}$

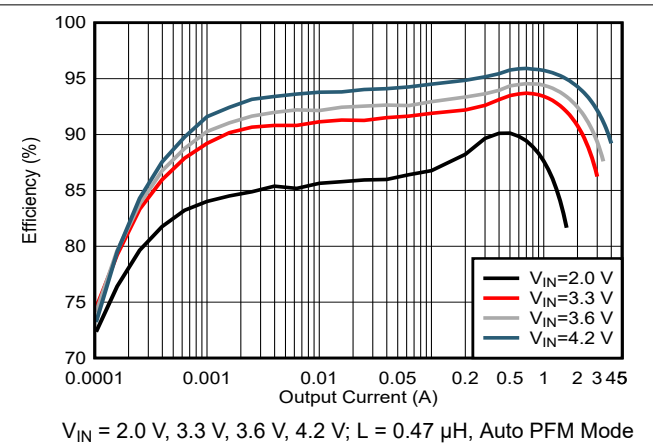

Figure 7-2. Efficiency vs Output Current $V_{OUT} = 5\text{ V}$

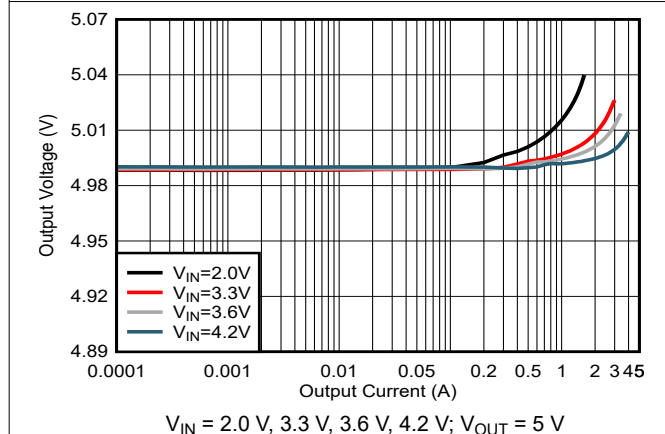

Figure 7-3. Load Regulation in Auto PWM

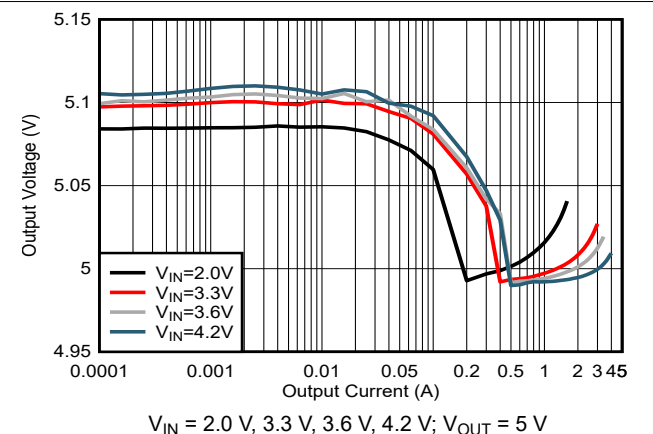

Figure 7-4. Load Regulation in Forced PFM

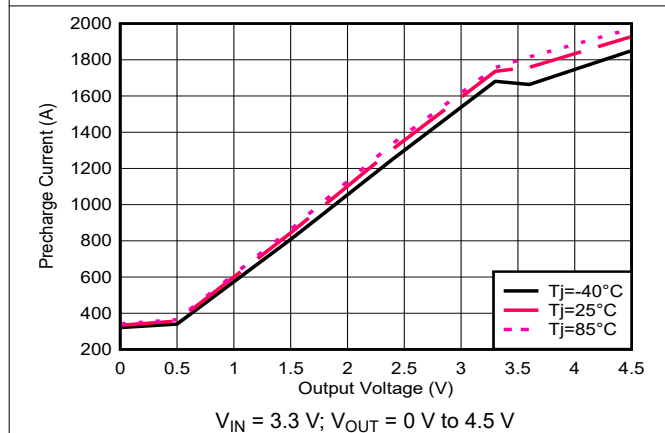

Figure 7-5. Pre-charge Current vs Output Voltage

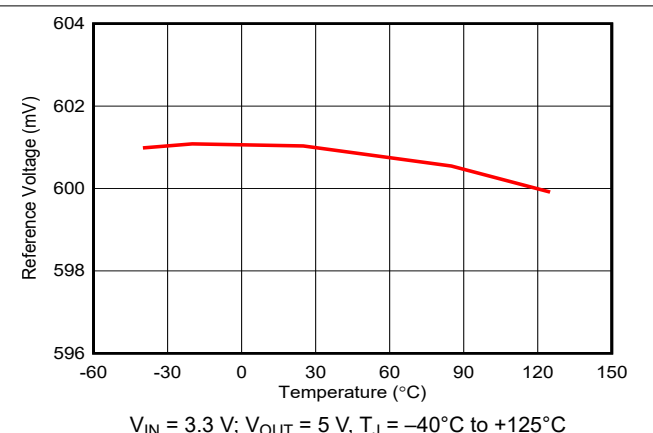
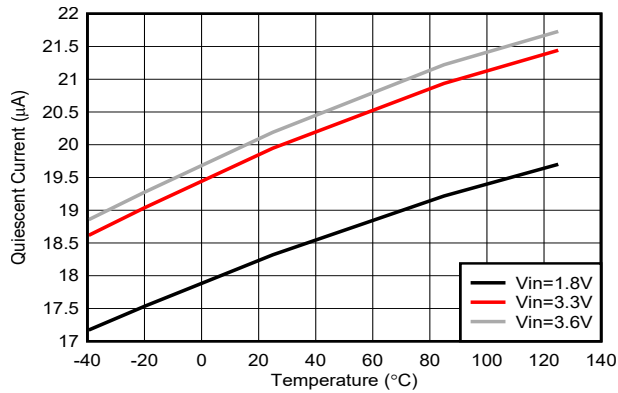
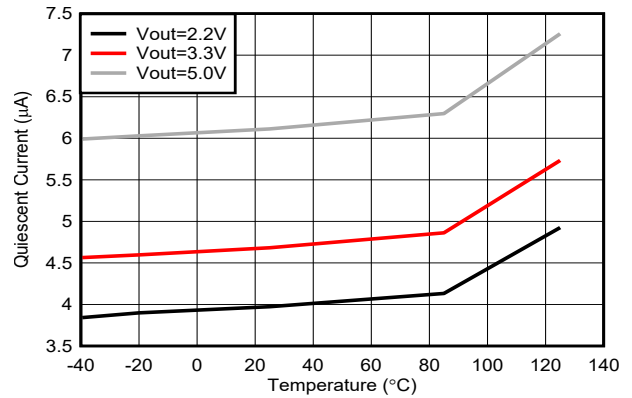

Figure 7-6. Reference Voltage vs Temperature



$V_{IN} = 1.8\text{ V}, 3.3\text{ V}, 3.6\text{ V}; V_{OUT} = 5\text{ V}; T_J = -40^\circ\text{C to } +125^\circ\text{C},$
No switching

Figure 7-7. Quiescent Current into VIN vs Temperature



$V_{IN} = 1.8\text{ V}; V_{OUT} = 2.2\text{ V}, 3.3\text{ V}, 5\text{ V}; T_J = -40^\circ\text{C to } +125^\circ\text{C},$
No switching

Figure 7-8. Quiescent Current into VOUT vs Temperature

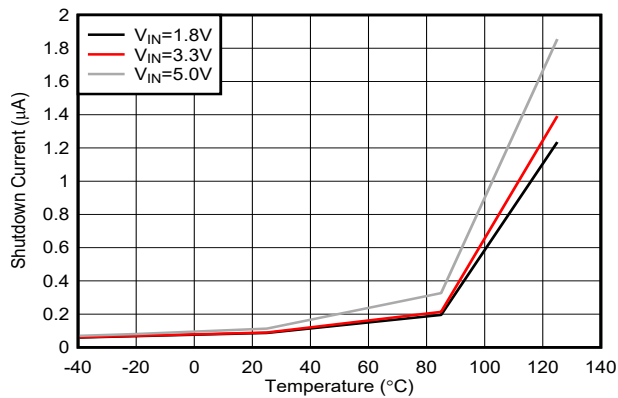

$V_{IN} = V_{SW} = 1.8\text{ V}, 3.3\text{ V}, 5\text{ V}; V_{OUT} = 0\text{ V}; T_J = -40^\circ\text{C to } +125^\circ\text{C}$

Figure 7-9. Shutdown Current vs Temperature

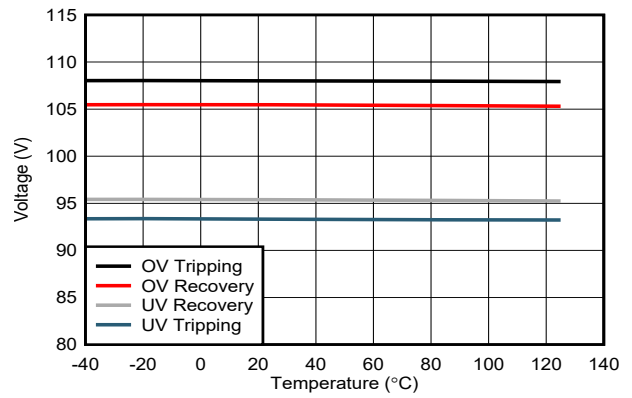

$V_{IN} = 3.6\text{ V}; V_{OUT} = 5\text{ V}; T_J = -40^\circ\text{C to } +125^\circ\text{C}$

Figure 7-10. PGOOD threshold vs Temperature

8 Detailed Description

8.1 Overview

The TPS61033 is a fully-integrated synchronous boost converter and operates from an input voltage supply range from 1.8 V to 5.5 V with 5.5-A (typical) valley switch current limit. The TPS61033 operates at 2.4-MHz switching frequency. There are two optional modes at light load by configuring the MODE pin: auto PFM mode and forced PWM to balance the efficiency and noise immunity in light load. The TPS61033 consumes an 20- μ A quiescent current from VIN at light load condition. During shutdown, the TPS61033 is completely disconnected from the input power and only consumes a 0.1- μ A current to achieve long battery life. During PWM operation, the converter uses adaptive constant on-time valley current mode control scheme to achieve excellent line regulation and load regulation and allows the use of a small inductor and ceramic capacitors. Internal loop compensation simplifies the design process while minimizing the number of external components.

8.2 Functional Block Diagram

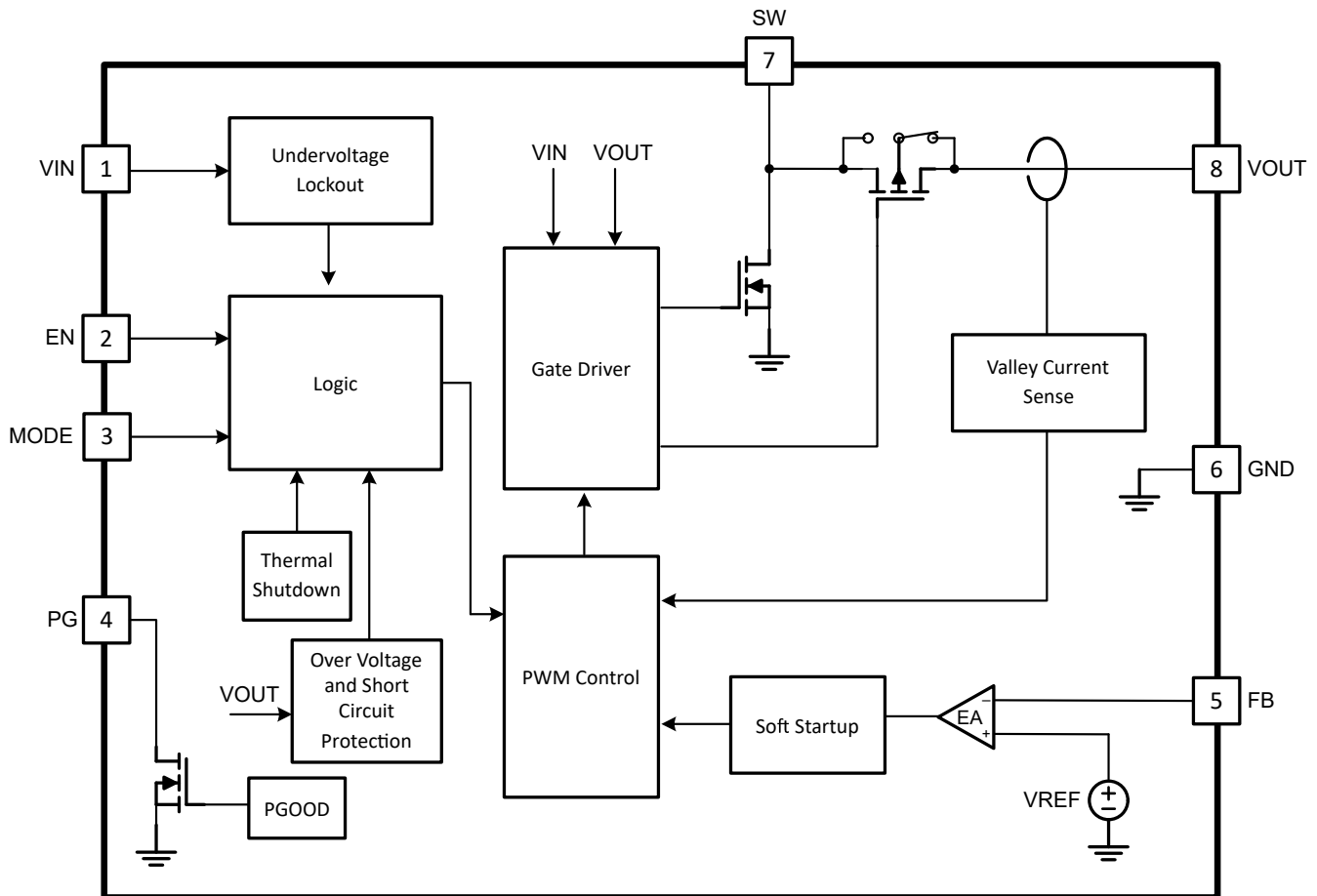

8.3 Feature Description

8.3.1 Undervoltage Lockout

The TPS61033 has a built-in undervoltage lockout (UVLO) circuit to ensure the device working properly. When the input voltage is above the UVLO rising threshold of 1.7 V (typical), the TPS61033 can be enabled to boost the output voltage. The device is disabled when the falling voltage at the VIN pin trips the UVLO falling threshold, which is 1.6 V (typical). A hysteresis of 100 mV (typical) is added so that the device cannot be enabled again until the input voltage exceeds 1.7 V (typical). This function is implemented to prevent the device from malfunctioning when the input voltage is between UVLO rising and falling threshold.

8.3.2 Enable and Soft Start

When the input voltage is above the UVLO rising threshold and the EN pin is pulled to a voltage above 1.2 V, the TPS61033 is enabled and starts up. To minimize the inrush current during start up, the TPS61033 has a soft start up function. At the beginning, the TPS61033 enters pre-charge phase and charges the output capacitors with a current of approximately 330 mA when the output voltage is below 0.4 V. When the output voltage is charged above 0.4 V, the output current is changed to having output current capability to drive the 2-Ω resistance load. To minimize the inrush current further, the TPS610333 has a maximum pre-charge current of 900 mA (typical). After the output voltage reaches the input voltage, the TPS61033 starts switching, and the reference voltage ramps up a 0.8 mV/μs. When the voltage at the EN pin is below 0.4 V, the internal enable comparator turns the device into shutdown mode. In the shutdown mode, the device is entirely turned off. The output is disconnected from input power supply.

8.3.3 Setting the Output Voltage

There are two ways to set the output voltage of the TPS61033: adjustable or fixed. If the FB is connected to VIN, the TPS61033 works as a fixed 5.0-V output voltage version, the TPS61033 uses the internal resistor divider.

The output voltage is also can be set by an external resistor divider (R1, R2 in [Figure 9-1](#)). When the output voltage is regulated, the typical voltage at the FB pin is V_{REF} . Thus the resistor divider is determined by [Equation 5](#).

$$R1 = \left(\frac{V_{OUT}}{V_{REF}} - 1 \right) \times R2 \quad (1)$$

where

- V_{OUT} is the regulated output voltage
- V_{REF} is the internal reference voltage at the FB pin

TPS610333 can only support fixed 5.0-V output voltage, so FB should be connected with VIN rather than external resistor divider.

8.3.4 Current Limit Operation

The TPS61033 uses a valley current limit sensing scheme. Current limit detection occurs during the off-time by sensing of the voltage drop across the synchronous rectifier.

When the load current is increased such that the inductor current is above the current limit within the whole switching cycle time, the off-time is increased to allow the inductor current to decrease to this threshold before the next on-time begins (so called frequency foldback mechanism). When the current limit is reached, the output voltage decreases during further load increase.

The maximum continuous output current ($I_{OUT(LC)}$), before entering current limit (CL) operation, can be defined by [Equation 2](#).

$$I_{OUT(CL)} = (1-D) \times \left(I_{LIM} + \frac{1}{2} \Delta I_{L(P-P)} \right) \quad (2)$$

where

- D is the duty cycle
- $\Delta I_{L(P-P)}$ is the inductor ripple current

The duty cycle can be estimated by [Equation 3](#).

$$D = 1 - \frac{V_{IN} \times \eta}{V_{OUT}} \quad (3)$$

where

- V_{OUT} is the output voltage of the boost converter
- V_{IN} is the input voltage of the boost converter
- η is the efficiency of the converter, use 90% for most applications

The peak-to-peak inductor ripple current is calculated by Equation 4.

$$\Delta I_{L(P-P)} = \frac{V_{IN} \times D}{L \times f_{SW}} \quad (4)$$

where

- L is the inductance value of the inductor
- f_{SW} is the switching frequency
- D is the duty cycle
- V_{IN} is the input voltage of the boost converter

8.3.5 Pass-Through Operation

When the input voltage is higher than the setting output voltage, the output voltage is higher than the target regulation voltage, the device works in pass-through mode. When the output voltage is 101% of the setting target voltage, the TPS61033 stops switching and fully turns on the high-side PMOS FET. The output voltage is the input voltage minus the voltage drop across the DCR of the inductor and the $R_{DS(on)}$ of the PMOS FET. When the output voltage drops below the 97% of the setting target voltage as the input voltage declines or the load current increases, the TPS61033 resumes switching again to regulate the output voltage.

8.3.6 Power Good Indicator

The TPS61033 integrates a power good indicator to simplify sequencing and supervision. The power-good output consists of an open-drain NMOS, requiring an external pullup resistor connect to a suitable voltage supply. The PG pin goes high with a typical 1.3 ms delay time after VOUT is between 93% (typical) and 107% (typical) of the target output voltage. When the output voltage is out of the target output voltage window, the PG pin immediately goes low with a 33 μ s deglitch filter delay. This deglitch filter also prevents any false pulldown of the PGOOD due to transients. When EN is pulled low, the PG pin is also forced low with a 33 μ s deglitch filter delay. If not used, the PG pin can be left floating or connected to GND.

8.3.7 Implement Output Discharge by PG function

The purpose of the output discharge function is to ensure a defined down-ramp of the output voltage and to let the output voltage close to 0 V quickly when the device is being disabled. TPS61033 can implement output discharge function by PG function that requires a R_{Dummy} resistor connected between PG pin and Vout pin. PG is an open drain NMOS architecture with up to 50 mA current capability, the PG pin becomes logic high when the output voltage reaches the target value, so the dummy load resistor doesn't lead any power loss during normal operation. When the EN pin gets low, the TPS61033 is disabled and meanwhile the PG pin gets low with a typical 33 μ s glitch time (t_{glitch}). With PG pin keeps low, the R_{Dummy} works as a dummy load to discharge output voltage. Changing R_{Dummy} can adjust the output discharge rate.

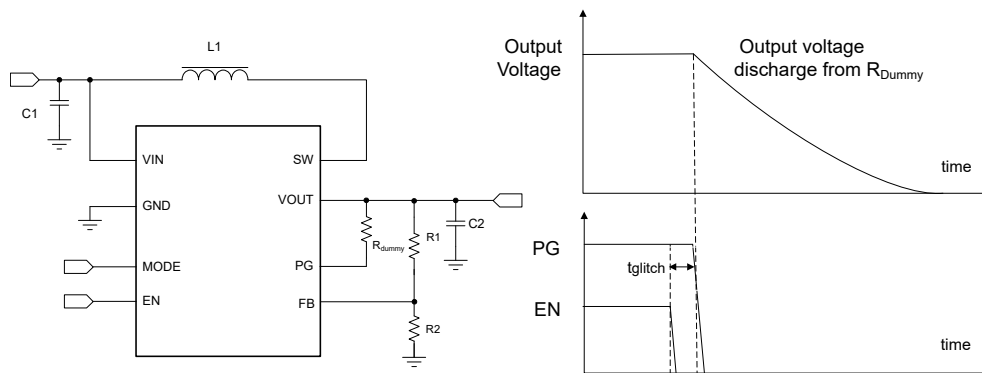

Figure 8-1. Implement Output Discharge by PG function

8.3.8 Overvoltage Protection

The TPS61033 has an output overvoltage protection (OVP) to protect the device if the external feedback resistor divider is wrongly populated. When the output voltage is above 5.75 V typically, the device stops switching. Once the output voltage falls 0.1 V below the OVP threshold, the device resumes operating again.

8.3.9 Output Short-to-Ground Protection

The TPS61033 starts to limit the output current when the output voltage is below 1.8 V. The lower the output voltage reaches, the smaller the output current is. When the VOUT pin is short to ground, and the output voltage becomes less than 0.4 V, the output current is limited to approximately 330 mA. Once the short circuit is released, the TPS61033 goes through the soft start-up again to the regulated output voltage.

8.3.10 Thermal Shutdown

The TPS61033 goes into thermal shutdown once the junction temperature exceeds 170°C. When the junction temperature drops below the thermal shutdown recovery temperature, typically 155°C, the device starts operating again.

8.4 Device Functional Modes

TPS61033 has two optional modes in light load by configuring the MODE pin: auto PFM mode and forced PWM to balance the efficiency and noise immunity in light load.

8.4.1 PWM Mode

The TPS61033 uses a quasi-constant 2.4-MHz frequency pulse width modulation (PWM) at moderate to heavy load current. Based on the input voltage to output voltage ratio, a circuit predicts the required on-time. At the beginning of the switching cycle, the NMOS switching FET. The input voltage is applied across the inductor and the inductor current ramps up. In this phase, the output capacitor is discharged by the load current. When the on-time expires, the main switch NMOS FET is turned off, and the rectifier PMOS FET is turned on. The inductor transfers its stored energy to replenish the output capacitor and supply the load. The inductor current declines because the output voltage is higher than the input voltage. When the inductor current hits the valley current threshold determined by the output of the error amplifier, the next switching cycle starts again.

The TPS61033 has a built-in compensation circuit that can accommodate a wide range of input voltage, output voltage, inductor value, and output capacitor value for stable operation.

8.4.2 Power-Save Mode

The TPS61033 integrates a power-save mode with PFM to improve efficiency at light load. When the load current decreases, the inductor valley current set by the output of the error amplifier no longer regulates the output voltage. When the inductor valley current hits the low limit, the output voltage exceeds the setting voltage as the load current decreases further. When the FB voltage hits the PFM reference voltage, the TPS61033 goes into the power-save mode. In the power-save mode, when the FB voltage rises and hits the PFM reference voltage, the device continues switching for several cycles because of the delay time of the internal comparator — then it stops switching. The load is supplied by the output capacitor, and the output voltage declines. When the FB voltage falls below the PFM reference voltage, after the delay time of the comparator, the device starts switching again to ramp up the output voltage.

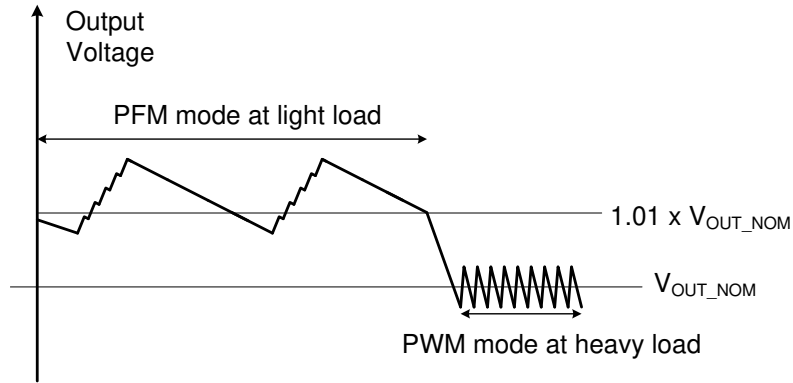

Figure 8-2. Output Voltage in PWM Mode and PFM Mode

9 Application and Implementation

Note

Information in the following applications sections is not part of the TI component specification, and TI does not warrant its accuracy or completeness. TI's customers are responsible for determining suitability of components for their purposes, as well as validating and testing their design implementation to confirm system functionality.

9.1 Application Information

The TPS61033 is a synchronous boost converter designed to operate from an input voltage supply range between 1.8 V and 5.5 V with a 5.5-A (typical) valley switch current limit. The TPS61033 typically operates at a quasi-constant 2.4-MHz frequency PWM at moderate-to-heavy load currents. At light load currents, the TPS61033 converter operates in power-save mode with PFM to achieve high efficiency over the entire load current range.

9.2 Typical Application

The TPS61033 provides a power supply solution for portable devices powered by batteries. With 5.5-A (typical) switch current capability, the TPS61033 can output 5 V and 2 A from a single-cell Li-ion battery.

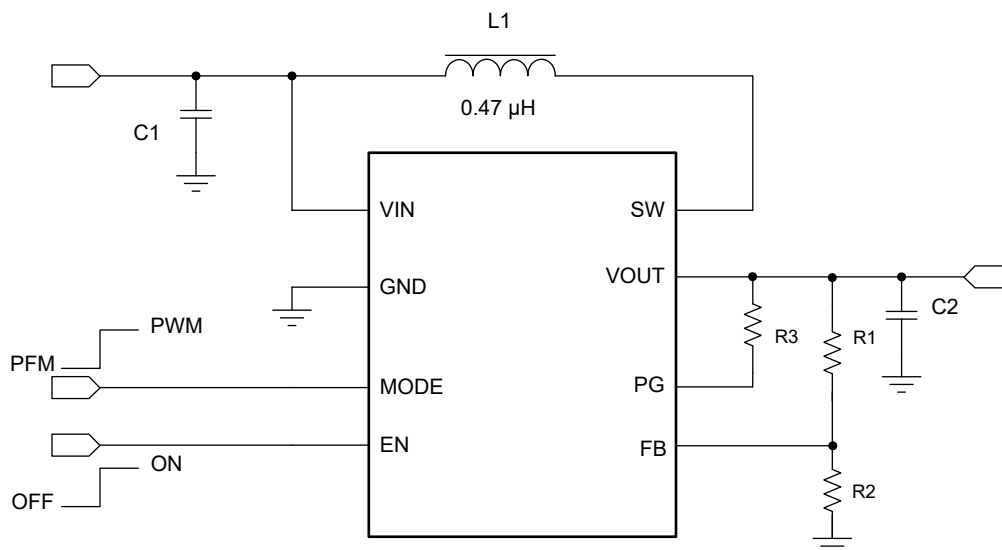

Figure 9-1. Li-ion Battery to 5-V Boost Converter

9.2.1 Design Requirements

The design parameters are listed in [Table 9-1](#).

Table 9-1. Design Parameters

PARAMETERS	VALUES
Input voltage	3.0 V to 4.35 V
Output voltage	5 V
Output current	2.0 A

9.2.2 Detailed Design Procedure

9.2.2.1 Setting the Output Voltage

The output voltage is set by an external resistor divider (R1, R2 in [Figure 9-1](#)). When the output voltage is regulated, the typical voltage at the FB pin is V_{REF} . Thus the resistor divider is determined by [Equation 5](#).

$$R1 = \left(\frac{V_{OUT}}{V_{REF}} - 1 \right) \times R2 \quad (5)$$

where

- V_{OUT} is the regulated output voltage
- V_{REF} is the internal reference voltage at the FB pin

For the best accuracy, keep R2 smaller than 300 k Ω to ensure the current flowing through R2 is at least 100 times larger than the FB pin leakage current. Changing R2 towards a lower value increases the immunity against noise injection. Changing the R2 towards a higher value reduces the quiescent current for achieving highest efficiency at low load currents.

9.2.2.2 Inductor Selection

Because the selection of the inductor affects steady-state operation, transient behavior, and loop stability. The inductor is the most important component in power regulator design. There are three important inductor specifications, inductor value, saturation current, and dc resistance (DCR).

The TPS61033 is designed to work with inductor values between 0.37 μ H and 2.9 μ H. Follow [Equation 6](#) to [Equation 8](#) to calculate the inductor peak current for the application. To calculate the current in the worst case, use the minimum input voltage, maximum output voltage, and maximum load current of the application. To have enough design margins, choose the inductor value with –30% tolerances, and low power-conversion efficiency for the calculation.

In a boost regulator, the inductor dc current can be calculated by [Equation 6](#).

$$I_{L(DC)} = \frac{V_{OUT} \times I_{OUT}}{V_{IN} \times \eta} \quad (6)$$

where

- V_{OUT} is the output voltage of the boost converter
- I_{OUT} is the output current of the boost converter
- V_{IN} is the input voltage of the boost converter
- η is the power conversion efficiency, use 90% for most applications

The inductor ripple current is calculated by [Equation 7](#).

$$\Delta I_{L(P-P)} = \frac{V_{IN} \times D}{L \times f_{SW}} \quad (7)$$

where

- D is the duty cycle, which can be calculated by [Equation 3](#)
- L is the inductance value of the inductor
- f_{SW} is the switching frequency
- V_{IN} is the input voltage of the boost converter

Therefore, the inductor peak current is calculated by [Equation 8](#).

$$I_{L(P)} = I_{L(DC)} + \frac{\Delta I_{L(P-P)}}{2} \quad (8)$$

Normally, it is advisable to work with an inductor peak-to-peak current of less than 40% of the average inductor current for maximum output current. A smaller ripple from a larger valued inductor reduces the magnetic hysteresis losses in the inductor and EMI. But in the same way, load transient response time is increased. The

saturation current of the inductor must be higher than the calculated peak inductor current. [Table 9-2](#) lists the recommended inductors for the TPS61033.

Table 9-2. Recommended Inductors for the TPS61033

PART NUMBER ⁽¹⁾	L (μH)	DCR MAX (mΩ)	SATURATION CURRENT (A)	SIZE (LxWxH)	VENDOR
XGL4020-471MEC	0.47	5.1	6.1	4 x 4 x 2.1	Coilcraft
XGL4020-102MEC	1	9.0	3.8	4 x 4 x 2.1	Coilcraft

(1) See [Third-party Products](#) disclaimer

9.2.2.3 Output Capacitor Selection

The output capacitor is mainly selected to meet the requirements for output ripple and loop stability. The ripple voltage is related to capacitor capacitance and its equivalent series resistance (ESR). Assuming a ceramic capacitor with zero ESR, the minimum capacitance needed for a given ripple voltage can be calculated by [Equation 9](#).

$$C_{OUT} = \frac{I_{OUT} \times D_{MAX}}{f_{SW} \times V_{RIPPLE}} \quad (9)$$

where

- D_{MAX} is the maximum switching duty cycle
- V_{RIPPLE} is the peak-to-peak output ripple voltage
- I_{OUT} is the maximum output current
- f_{SW} is the switching frequency

The ESR impact on the output ripple must be considered if tantalum or aluminum electrolytic capacitors are used. The output peak-to-peak ripple voltage caused by the ESR of the output capacitors can be calculated by [Equation 10](#).

$$V_{RIPPLE(ESR)} = I_{L(P)} \times R_{ESR} \quad (10)$$

Take care when evaluating the derating of a ceramic capacitor under dc bias voltage, aging, and ac signal. For example, the dc bias voltage can significantly reduce capacitance. A ceramic capacitor can lose more than 50% of its capacitance at its rated voltage. Therefore, always leave margin on the voltage rating to ensure adequate capacitance at the required output voltage. Increasing the output capacitor makes the output ripple voltage smaller in PWM mode.

TI recommends using the X5R or X7R ceramic output capacitor in the range of 4-μF to 1000-μF effective capacitance. The output capacitor affects the small signal control loop stability of the boost regulator. If the output capacitor is below the range, the boost regulator can potentially become unstable. Increasing the output capacitor makes the output ripple voltage smaller in PWM mode.

9.2.2.4 Input Capacitor Selection

Multilayer X5R or X7R ceramic capacitors are excellent choices for the input decoupling of the step-up converter as they have extremely low ESR and are available in small footprints. Input capacitors must be located as close as possible to the device. While a 10-μF input capacitor is sufficient for most applications, larger values may be used to reduce input current ripple without limitations. Take care when using only ceramic input capacitors. When a ceramic capacitor is used at the input and the power is being supplied through long wires, a load step at the output can induce ringing at the VIN pin. This ringing can couple to the output and be mistaken as loop instability or even damage the part. In this circumstance, place additional bulk capacitance (tantalum or aluminum electrolytic capacitor) between ceramic input capacitor and the power source to reduce ringing that can occur between the inductance of the power source leads and ceramic input capacitor.

9.2.3 Application Curves

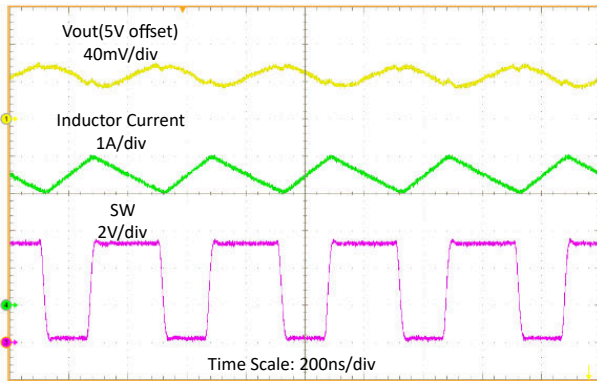

$V_{IN} = 3.3\text{ V}$, $V_{OUT} = 5\text{ V}$, $I_{OUT} = 2\text{ A}$

Figure 9-2. Switching Waveform at Heavy Load

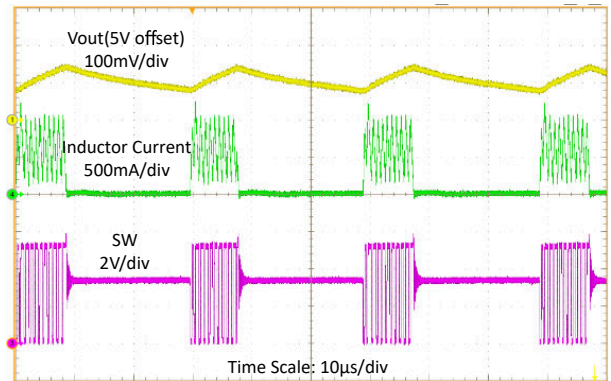

$V_{IN} = 3.3\text{ V}$, $V_{OUT} = 5\text{ V}$, $I_{OUT} = 100\text{ mA}$

Figure 9-3. Switching Waveform at Light Load

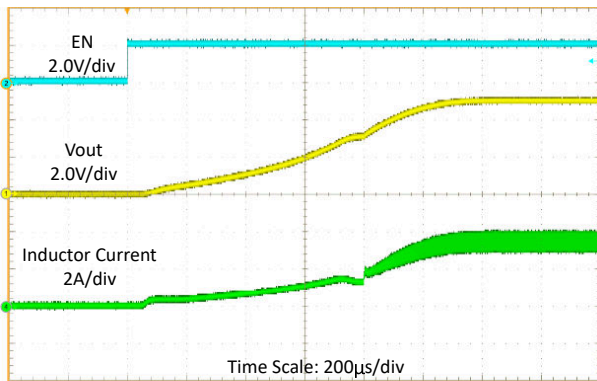

$V_{IN} = 3.3\text{ V}$, $V_{OUT} = 5\text{ V}$, $2.5\text{-}\Omega$ resistance load

Figure 9-4. Start-up Waveform

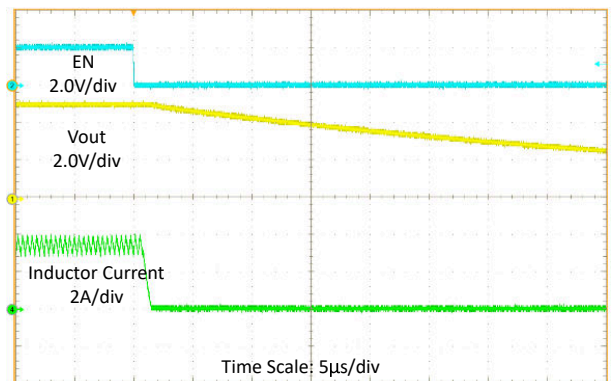

$V_{IN} = 3.3\text{ V}$, $V_{OUT} = 5\text{ V}$, $2.5\text{-}\Omega$ resistance load

Figure 9-5. Shutdown Waveform

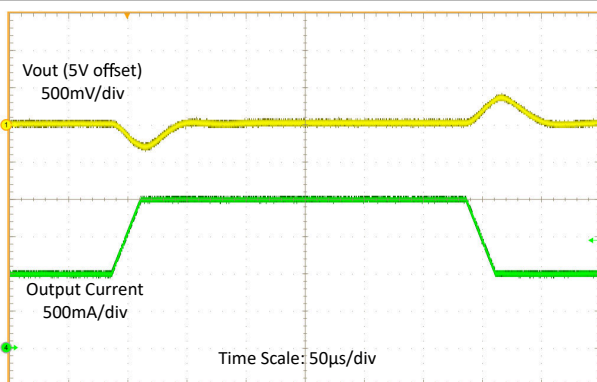

$V_{IN} = 3.3\text{ V}$, $V_{OUT} = 5\text{ V}$, $I_{OUT} = 1\text{ A}$ to 2 A with $20\text{-}\mu\text{s}$ slew rate

Figure 9-6. Load Transient

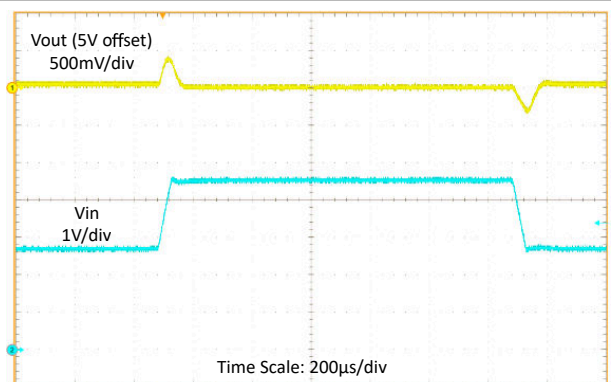

$V_{IN} = 2.7\text{ V}$ to 4.5 V with $20\text{-}\mu\text{s}$ slew rate, $V_{OUT} = 5\text{ V}$, $I_{OUT} = 2\text{ A}$

Figure 9-7. Line Transient

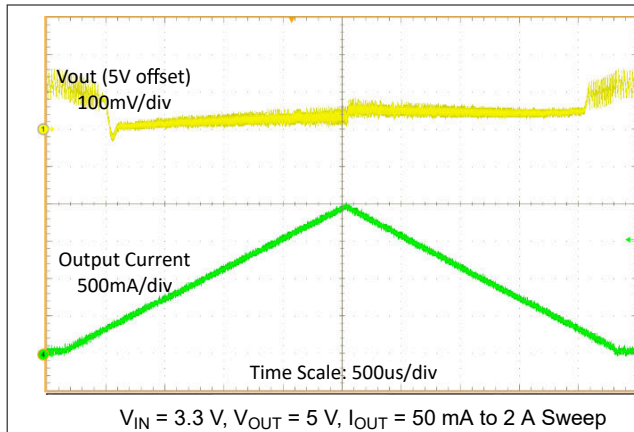

Figure 9-8. Load Sweep

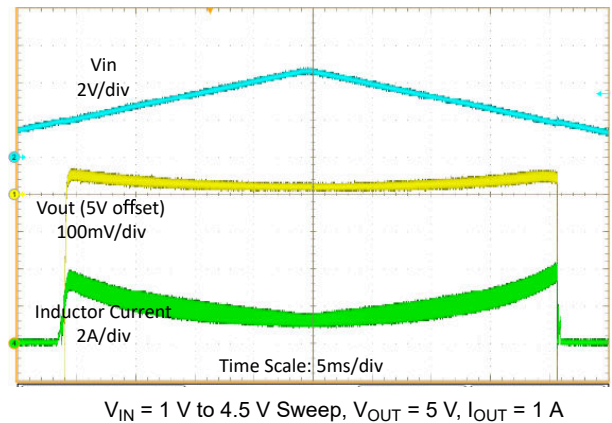

Figure 9-9. Line Sweep

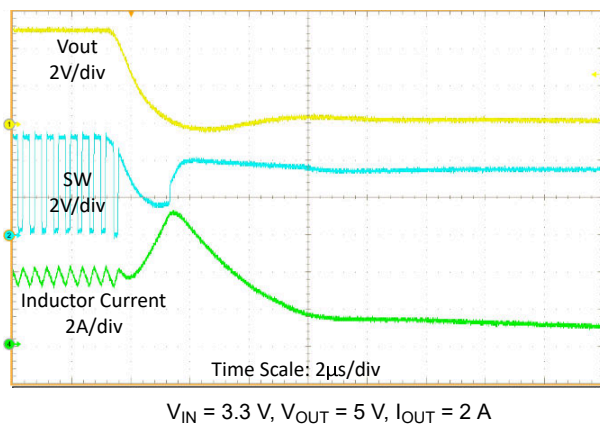

Figure 9-10. Output Short Protection (Entry)

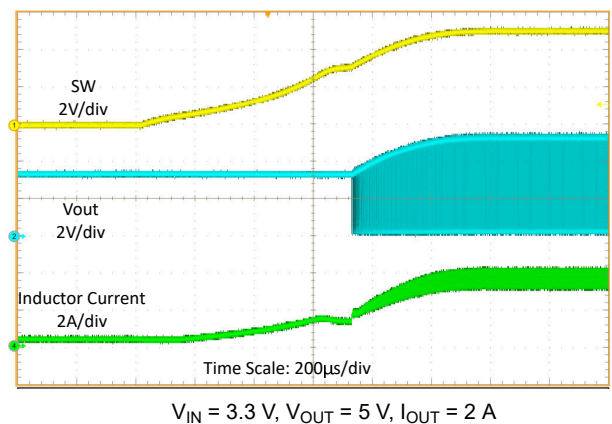

Figure 9-11. Output Short Protection (Recover)

9.3 Power Supply Recommendations

The device is designed to operate from an input voltage supply range between 1.8 V to 5.5 V. This input supply must be well regulated. If the input supply is located more than a few inches from the converter, additional bulk capacitance may be required in addition to the ceramic bypass capacitors. A typical choice is a tantalum or aluminum electrolytic capacitor with a value of 100 μF . Output current of the input power supply must be rated according to the supply voltage, output voltage, and output current of the TPS61033.

9.4 Layout

9.4.1 Layout Guidelines

As for all switching power supplies, especially those running at high switching frequency and high currents, layout is an important design step. If the layout is not carefully done, the regulator suffers from instability and noise problems. To maximize efficiency, switch rise and fall time are very fast. To prevent radiation of high frequency noise (for example, EMI), proper layout of the high-frequency switching path is essential. Minimize the length and area of all traces connected to the SW pin, and always use a ground plane under the switching regulator to minimize interplane coupling. The input capacitor needs not only to be close to the VIN pin, but also to the GND pin in order to reduce input supply ripple.

The most critical current path for all boost converters is from the switching FET, through the rectifier FET, then the output capacitors, and back to ground of the switching FET. This high current path contains nanosecond rise and fall time and must be kept as short as possible. Therefore, the output capacitor not only must be close to the VOUT pin, but also to the GND pin to reduce the overshoot at the SW pin and VOUT pin.

For better thermal performance, TI suggest to make copper polygon connected with each pin bigger.

9.4.2 Layout Example

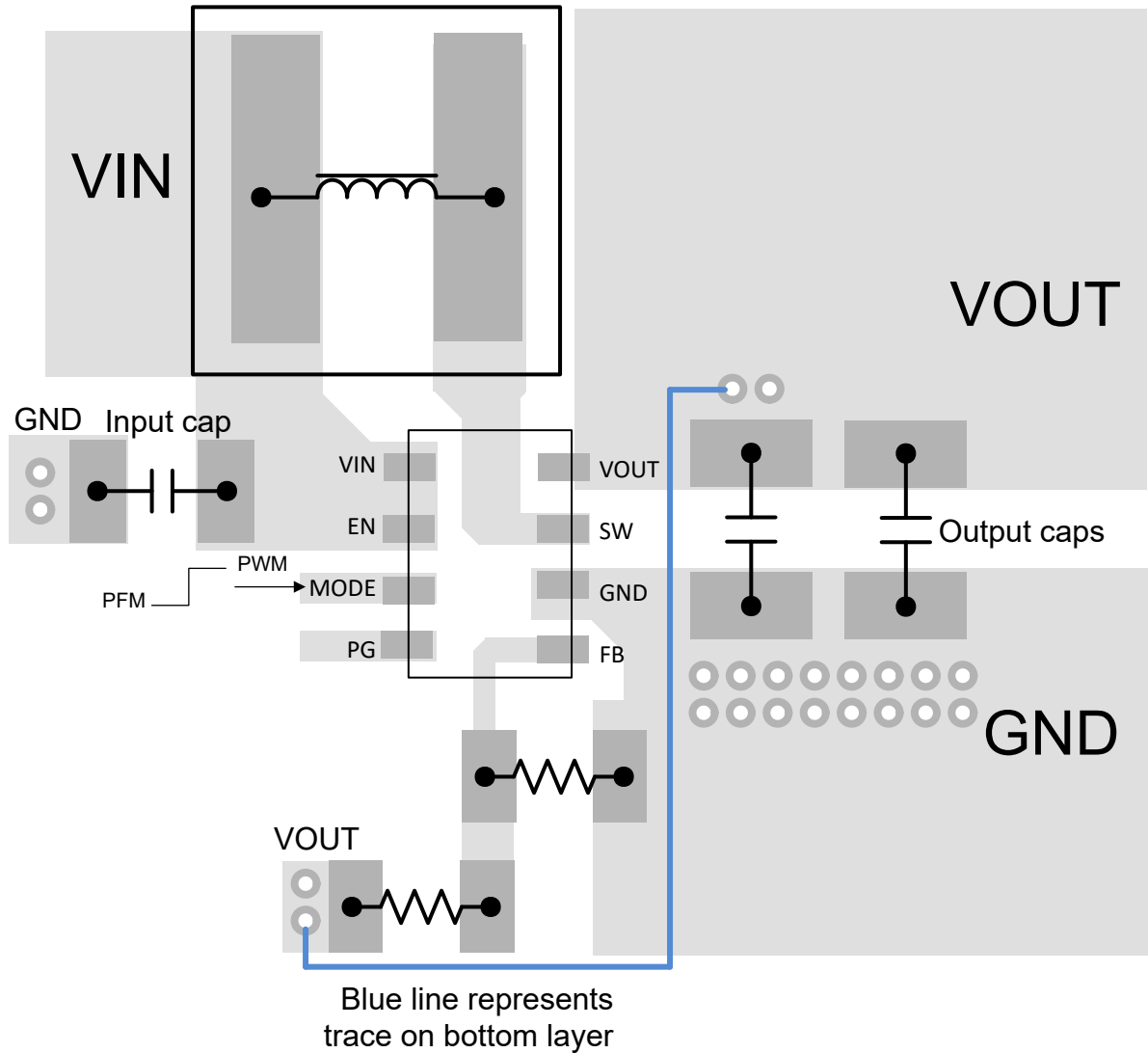

Figure 9-12. Layout Example

9.4.3 Thermal Considerations

Restrict the maximum IC junction temperature to 125°C under normal operating conditions. Calculate the maximum allowable dissipation, $P_{D(max)}$, and keep the actual power dissipation less than or equal to $P_{D(max)}$. The maximum-power-dissipation limit is determined using [Equation 11](#).

$$P_{D(max)} = \frac{125 - T_A}{R_{\theta JA}} \quad (11)$$

where

- T_A is the maximum ambient temperature for the application
- $R_{\theta JA}$ is the junction-to-ambient thermal resistance given in [Section 9.4.3](#)

The TPS61033 comes in a SOT583 package. The real junction-to-ambient thermal resistance of the package greatly depends on the PCB type, layout. Using larger and thicker PCB copper for the power pads (GND, SW, and VOUT) to enhance the thermal performance. Using more vias connects the ground plate on the top layer and bottom layer around the IC without solder mask also improves the thermal capability.

10 Device and Documentation Support

10.1 Device Support

10.1.1 Third-Party Products Disclaimer

TI'S PUBLICATION OF INFORMATION REGARDING THIRD-PARTY PRODUCTS OR SERVICES DOES NOT CONSTITUTE AN ENDORSEMENT REGARDING THE SUITABILITY OF SUCH PRODUCTS OR SERVICES OR A WARRANTY, REPRESENTATION OR ENDORSEMENT OF SUCH PRODUCTS OR SERVICES, EITHER ALONE OR IN COMBINATION WITH ANY TI PRODUCT OR SERVICE.

10.2 Receiving Notification of Documentation Updates

To receive notification of documentation updates, navigate to the device product folder on [ti.com](https://www.ti.com). Click on *Subscribe to updates* to register and receive a weekly digest of any product information that has changed. For change details, review the revision history included in any revised document.

10.3 Support Resources

[TI E2E™ support forums](#) are an engineer's go-to source for fast, verified answers and design help — straight from the experts. Search existing answers or ask your own question to get the quick design help you need.

Linked content is provided "AS IS" by the respective contributors. They do not constitute TI specifications and do not necessarily reflect TI's views; see TI's [Terms of Use](#).

10.4 Trademarks

TI E2E™ is a trademark of Texas Instruments.
All trademarks are the property of their respective owners.

10.5 Electrostatic Discharge Caution



This integrated circuit can be damaged by ESD. Texas Instruments recommends that all integrated circuits be handled with appropriate precautions. Failure to observe proper handling and installation procedures can cause damage.

ESD damage can range from subtle performance degradation to complete device failure. Precision integrated circuits may be more susceptible to damage because very small parametric changes could cause the device not to meet its published specifications.

10.6 Glossary

[TI Glossary](#) This glossary lists and explains terms, acronyms, and definitions.

11 Mechanical, Packaging, and Orderable Information

The following pages include mechanical, packaging, and orderable information. This information is the most current data available for the designated devices. This data is subject to change without notice and revision of this document. For browser-based versions of this data sheet, refer to the left-hand navigation.

PACKAGING INFORMATION

Orderable Device	Status (1)	Package Type	Package Drawing	Pins	Package Qty	Eco Plan (2)	Lead finish/ Ball material (6)	MSL Peak Temp (3)	Op Temp (°C)	Device Marking (4/5)	Samples
TPS610333DRLR	ACTIVE	SOT-5X3	DRL	8	4000	RoHS & Green	Call TI SN	Level-1-260C-UNLIM	-40 to 125	0333	Samples
TPS61033DRLR	ACTIVE	SOT-5X3	DRL	8	4000	RoHS & Green	Call TI SN	Level-1-260C-UNLIM	-40 to 125	033	Samples

(1) The marketing status values are defined as follows:

ACTIVE: Product device recommended for new designs.

LIFEBUY: TI has announced that the device will be discontinued, and a lifetime-buy period is in effect.

NRND: Not recommended for new designs. Device is in production to support existing customers, but TI does not recommend using this part in a new design.

PREVIEW: Device has been announced but is not in production. Samples may or may not be available.

OBSOLETE: TI has discontinued the production of the device.

(2) **RoHS:** TI defines "RoHS" to mean semiconductor products that are compliant with the current EU RoHS requirements for all 10 RoHS substances, including the requirement that RoHS substance do not exceed 0.1% by weight in homogeneous materials. Where designed to be soldered at high temperatures, "RoHS" products are suitable for use in specified lead-free processes. TI may reference these types of products as "Pb-Free".

RoHS Exempt: TI defines "RoHS Exempt" to mean products that contain lead but are compliant with EU RoHS pursuant to a specific EU RoHS exemption.

Green: TI defines "Green" to mean the content of Chlorine (Cl) and Bromine (Br) based flame retardants meet JS709B low halogen requirements of <=1000ppm threshold. Antimony trioxide based flame retardants must also meet the <=1000ppm threshold requirement.

(3) MSL, Peak Temp. - The Moisture Sensitivity Level rating according to the JEDEC industry standard classifications, and peak solder temperature.

(4) There may be additional marking, which relates to the logo, the lot trace code information, or the environmental category on the device.

(5) Multiple Device Markings will be inside parentheses. Only one Device Marking contained in parentheses and separated by a "~" will appear on a device. If a line is indented then it is a continuation of the previous line and the two combined represent the entire Device Marking for that device.

(6) Lead finish/Ball material - Orderable Devices may have multiple material finish options. Finish options are separated by a vertical ruled line. Lead finish/Ball material values may wrap to two lines if the finish value exceeds the maximum column width.

Important Information and Disclaimer:The information provided on this page represents TI's knowledge and belief as of the date that it is provided. TI bases its knowledge and belief on information provided by third parties, and makes no representation or warranty as to the accuracy of such information. Efforts are underway to better integrate information from third parties. TI has taken and continues to take reasonable steps to provide representative and accurate information but may not have conducted destructive testing or chemical analysis on incoming materials and chemicals. TI and TI suppliers consider certain information to be proprietary, and thus CAS numbers and other limited information may not be available for release.

In no event shall TI's liability arising out of such information exceed the total purchase price of the TI part(s) at issue in this document sold by TI to Customer on an annual basis.

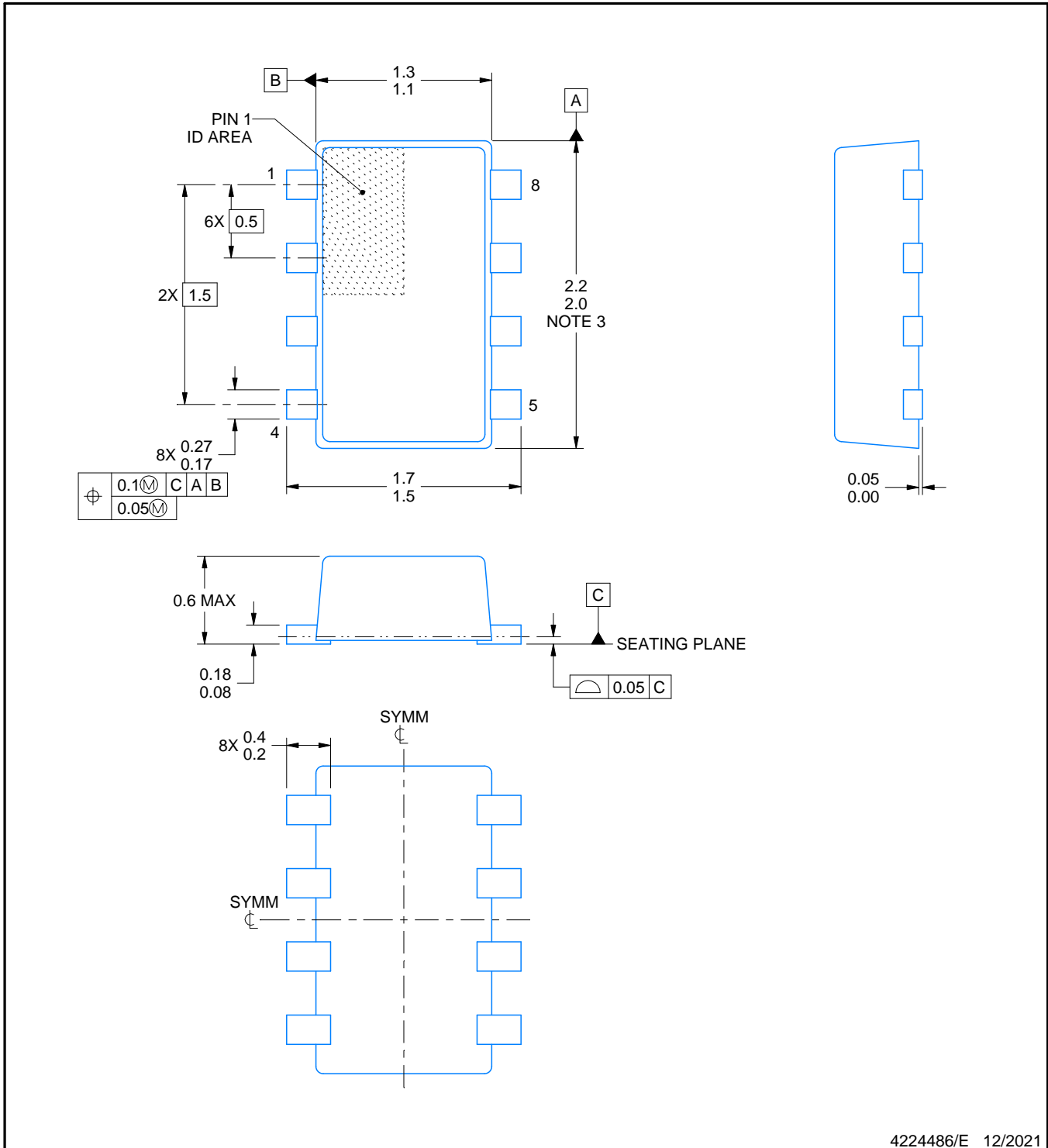

4224486/E 12/2021

NOTES:

1. All linear dimensions are in millimeters. Any dimensions in parenthesis are for reference only. Dimensioning and tolerancing per ASME Y14.5M.
2. This drawing is subject to change without notice.
3. This dimension does not include mold flash, protrusions, or gate burrs. Mold flash, interlead flash, protrusions, or gate burrs shall not exceed 0.15 mm per side.
4. Reference JEDEC Registration MO-293, Variation UDAD

EXAMPLE BOARD LAYOUT

DRL0008A

SOT-5X3 - 0.6 mm max height

PLASTIC SMALL OUTLINE

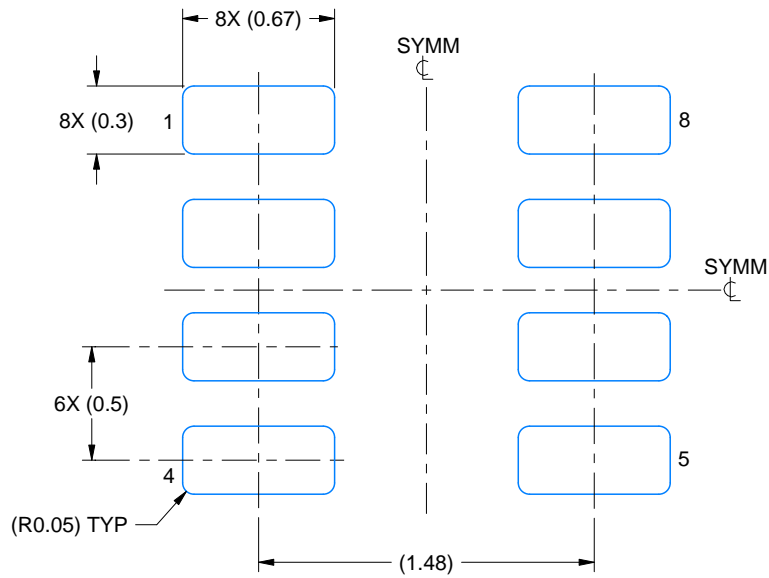

LAND PATTERN EXAMPLE
EXPOSED METAL SHOWN
SCALE:30X

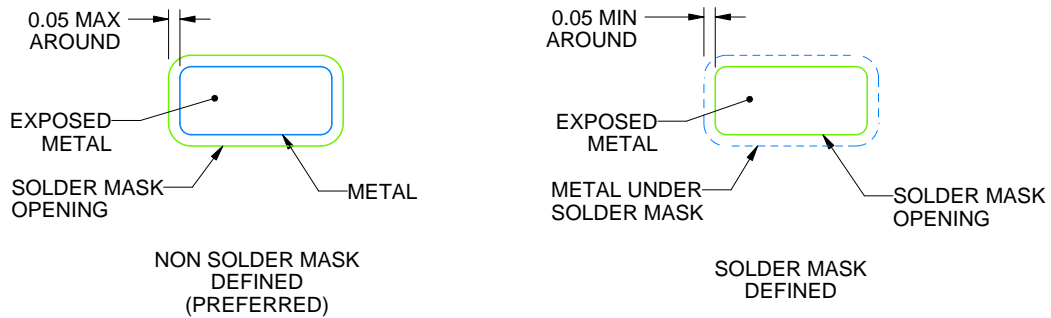

SOLDERMASK DETAILS

4224486/E 12/2021

NOTES: (continued)

- 5. Publication IPC-7351 may have alternate designs.
- 6. Solder mask tolerances between and around signal pads can vary based on board fabrication site.
- 7. Land pattern design aligns to IPC-610, Bottom Termination Component (BTC) solder joint inspection criteria.

EXAMPLE STENCIL DESIGN

DRL0008A

SOT-5X3 - 0.6 mm max height

PLASTIC SMALL OUTLINE

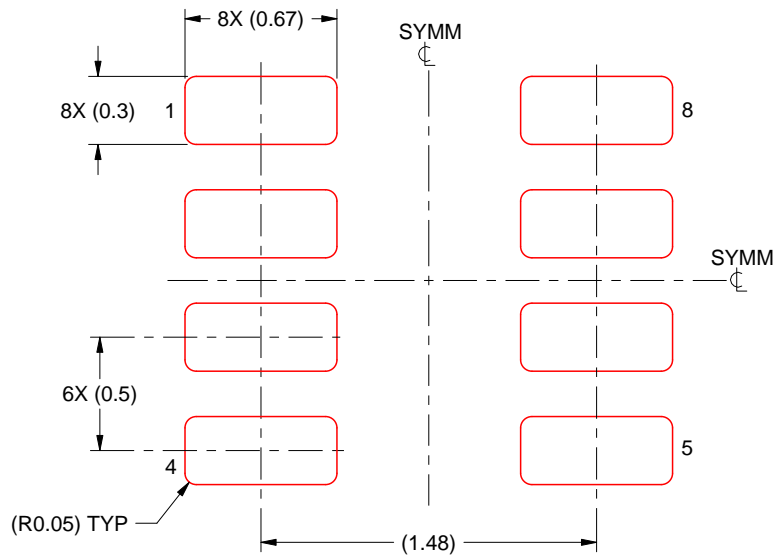

SOLDER PASTE EXAMPLE
BASED ON 0.1 mm THICK STENCIL
SCALE:30X

4224486/E 12/2021

NOTES: (continued)

8. Laser cutting apertures with trapezoidal walls and rounded corners may offer better paste release. IPC-7525 may have alternate design recommendations.
9. Board assembly site may have different recommendations for stencil design.

IMPORTANT NOTICE AND DISCLAIMER

TI PROVIDES TECHNICAL AND RELIABILITY DATA (INCLUDING DATA SHEETS), DESIGN RESOURCES (INCLUDING REFERENCE DESIGNS), APPLICATION OR OTHER DESIGN ADVICE, WEB TOOLS, SAFETY INFORMATION, AND OTHER RESOURCES "AS IS" AND WITH ALL FAULTS, AND DISCLAIMS ALL WARRANTIES, EXPRESS AND IMPLIED, INCLUDING WITHOUT LIMITATION ANY IMPLIED WARRANTIES OF MERCHANTABILITY, FITNESS FOR A PARTICULAR PURPOSE OR NON-INFRINGEMENT OF THIRD PARTY INTELLECTUAL PROPERTY RIGHTS.

These resources are intended for skilled developers designing with TI products. You are solely responsible for (1) selecting the appropriate TI products for your application, (2) designing, validating and testing your application, and (3) ensuring your application meets applicable standards, and any other safety, security, regulatory or other requirements.

These resources are subject to change without notice. TI grants you permission to use these resources only for development of an application that uses the TI products described in the resource. Other reproduction and display of these resources is prohibited. No license is granted to any other TI intellectual property right or to any third party intellectual property right. TI disclaims responsibility for, and you will fully indemnify TI and its representatives against, any claims, damages, costs, losses, and liabilities arising out of your use of these resources.

TI's products are provided subject to [TI's Terms of Sale](#) or other applicable terms available either on [ti.com](https://www.ti.com) or provided in conjunction with such TI products. TI's provision of these resources does not expand or otherwise alter TI's applicable warranties or warranty disclaimers for TI products.

TI objects to and rejects any additional or different terms you may have proposed.

Mailing Address: Texas Instruments, Post Office Box 655303, Dallas, Texas 75265
Copyright © 2023, Texas Instruments Incorporated

Looking for pricing, stock, or lifecycle information?

Click below to explore more details on WIN SOURCE:

 [View TPS61033DRLR on WIN SOURCE](#)

 [Texas Instruments](#) Information

Optimize Your Supply Chain with WIN SOURCE Solutions

-  Global Sourcing Solution
-  Obsolete Management
-  Cost Control Management
-  Shortage Management
-  Alternative Solution
-  Excess Inventory Management