



**THE DATASHEET OF
LT6376HMS#PBF**



±230V Common Mode Voltage G = 10 Difference Amplifier

FEATURES

- ±230V Common Mode Voltage Range
- 105nV/√Hz Input Referred Noise (Resistor Divider = 3.1)
- 90dB Minimum CMRR
- 0.0075% (75ppm) Maximum Gain Error
- 1ppm/°C Maximum Gain Error Drift
- 2ppm Maximum Gain Nonlinearity
- Wide Supply Voltage Range: 3.3V to 50V
- Rail-to-Rail Output
- 350µA Supply Current
- Selectable Internal Resistor Divider Ratio
- 200µV Maximum Input Offset Voltage
- 300kHz -3dB Bandwidth (Resistor Divider = 3.1)
- 160kHz -3dB Bandwidth (Resistor Divider = 10.3)
- -40°C to 125°C Specified Temperature Range
- Low Power Shutdown: 20µA (DFN Package Only)
- Space-Saving MSOP and DFN Packages

APPLICATIONS

- High Side or Low Side Current Sensing
- Bidirectional Wide Common Mode Range Current Sensing
- High Voltage to Low Voltage Level Translation
- Precision Difference Amplifier
- Replacement for Isolation Circuits

DESCRIPTION

The LT[®]6376 is a gain of 10 difference amplifier which combines excellent DC precision, a very high input common mode range and a wide supply voltage range. It includes a precision op amp and a highly-matched thin film resistor network. It features excellent CMRR, extremely low gain error and extremely low gain drift.

Comparing the LT6376 to existing difference amplifiers with high common mode voltage range, the gain of 10 and selectable resistor divider ratios of the LT6376 offer superior system performance by allowing the user to achieve low input referred noise with maximum precision and speed.

The op amp at the core of the LT6376 has Over-The-Top[®] protected inputs which allow for robust operation in environments with unpredictable voltage conditions. See the Applications Information section for more details.

The LT6376 is specified over the -40°C to 125°C temperature range and is available in space-saving MSOP16 and DFN14 packages.

All registered trademarks and trademarks are the property of their respective owners.

TYPICAL APPLICATION

Precision Wide Voltage Range, Bidirectional Current Monitor

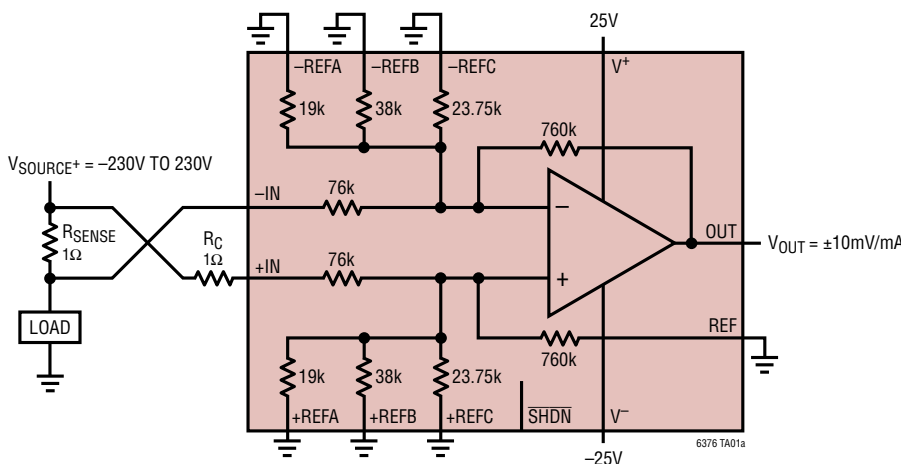

Typical Distribution of CMRR

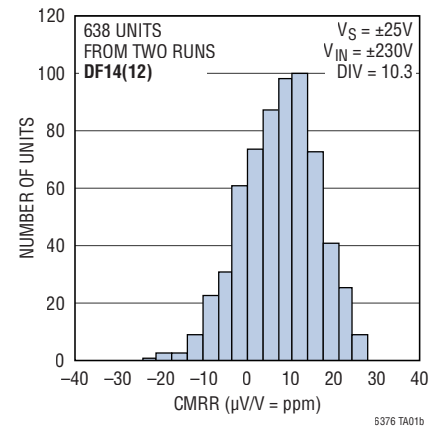

LT6376

ABSOLUTE MAXIMUM RATINGS

(Note 1)

Supply Voltages

(V^+ to V^-)60V

+IN, -IN, (Note 2)

Each Input..... $\pm 240V$

Differential $\pm 480V$

+REFA, -REFA, +REFB, -REFB, +REFC, -REFC,

REF, \overline{SHDN} (Note 2) ($V^+ + 0.3V$) to ($V^- - 0.3V$)

Output Current (Continuous) (Note 6)50mA

Output Short-Circuit Duration (Note 3) Thermally Limited
Temperature Range (Notes 4, 5)

LT6376I $-40^\circ C$ to $85^\circ C$

LT6376H $-40^\circ C$ to $125^\circ C$

Storage Temperature Range $-65^\circ C$ to $150^\circ C$

MSOP Lead Temperature (Soldering, 10 sec)..... $300^\circ C$

PIN CONFIGURATION

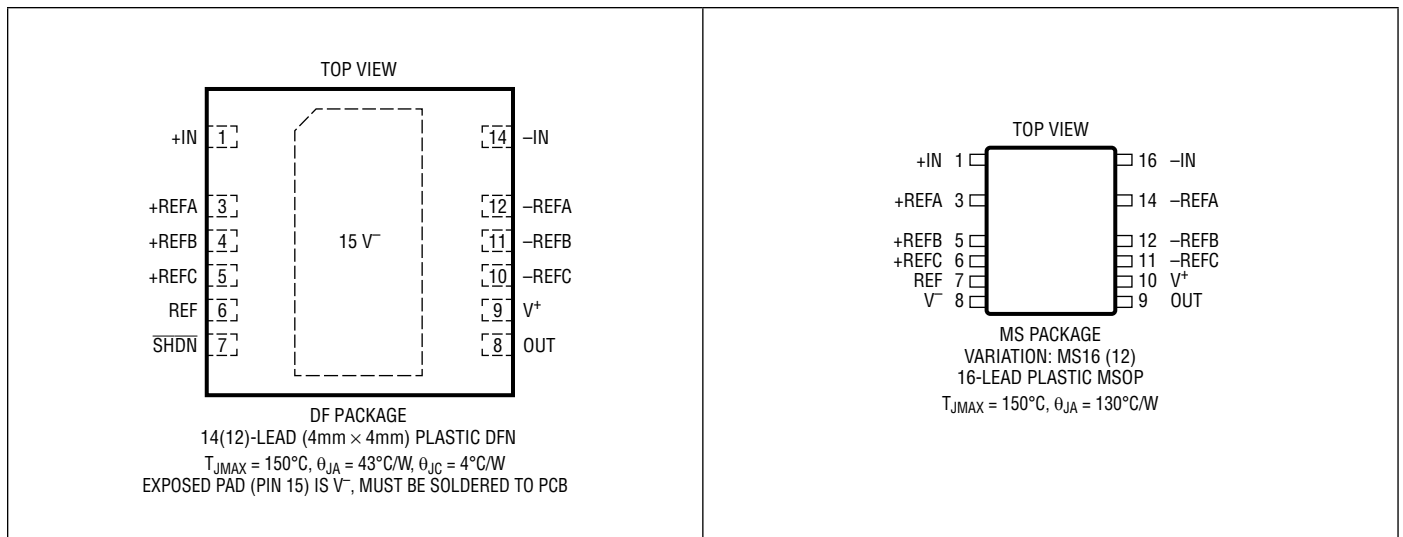

ORDER INFORMATION <http://www.linear.com/product/LT6376#orderinfo>

| TUBE | TAPE AND REEL | PART MARKING* | PACKAGE DESCRIPTION | TEMPERATURE RANGE |
|---------------|-----------------|---------------|---------------------------------|--------------------------------|
| LT6376IDF#PBF | LT6376IDF#TRPBF | 6376 | 14-Lead (4mm x 4mm) Plastic DFN | $-40^\circ C$ to $85^\circ C$ |
| LT6376HDF#PBF | LT6376HDF#TRPBF | 6376 | 14-Lead (4mm x 4mm) Plastic DFN | $-40^\circ C$ to $125^\circ C$ |
| LT6376IMS#PBF | LT6376IMS#TRPBF | 6376 | 16-Lead Plastic MSOP | $-40^\circ C$ to $85^\circ C$ |
| LT6376HMS#PBF | LT6376HMS#TRPBF | 6376 | 16-Lead Plastic MSOP | $-40^\circ C$ to $125^\circ C$ |

*The temperature grade is identified by a label on the shipping container.

Consult ADI Marketing for parts specified with wider operating temperature ranges. Parts ending with PBF are RoHS and WEEE compliant.

For more information on lead free part marking, go to: <http://www.linear.com/leadfree/>

For more information on tape and reel specifications, go to: <http://www.linear.com/tapeandree/>. Some packages are available in 500 unit reels through designated sales channels with #TRMPBF suffix.

ELECTRICAL CHARACTERISTICS The ● denotes the specifications which apply over the full operating temperature range, $-40^{\circ}\text{C} < T_A < 85^{\circ}\text{C}$ for I-grade parts, $-40^{\circ}\text{C} < T_A < 125^{\circ}\text{C}$ for H-grade parts, otherwise specifications are at $T_A = 25^{\circ}\text{C}$, $V^+ = 15\text{V}$, $V^- = -15\text{V}$, $V_{\text{CM}} = V_{\text{OUT}} = V_{\text{REF}} = 0\text{V}$. V_{CMOP} is the common mode voltage of the internal op amp. For Resistor Divider Ratio = 3.1, $\pm\text{REFA} = \pm\text{REFC} = \text{OPEN}$, $\pm\text{REFB} = 0\text{V}$. For Resistor Divider Ratio = 8.3, $\pm\text{REFA} = \pm\text{REFC} = 0\text{V}$, $\pm\text{REFB} = \text{OPEN}$. For Resistor Divider Ratio = 10.3, $\pm\text{REFA} = \pm\text{REFB} = \pm\text{REFC} = 0\text{V}$.

| SYMBOL | PARAMETER | CONDITIONS | MIN | TYP | MAX | UNITS | |
|---------------------------------------|---|--|-----------------------|--|--|--|--|
| G | Gain | $V_{\text{OUT}} = \pm 10\text{V}$ | | 10 | | V/V | |
| ΔG | Gain Error, MS16 Package | $V_{\text{OUT}} = \pm 10\text{V}$ | ● | ± 0.002 | ± 0.0075 ± 0.0085 | % % | |
| ΔG | Gain Error, DF14 Package | $V_{\text{OUT}} = \pm 10\text{V}$ | ● | ± 0.002 | ± 0.0085 ± 0.0095 | % % | |
| $\Delta\text{G}/\Delta\text{T}$ | Gain Drift vs Temperature (Note 6) | $V_{\text{OUT}} = \pm 10\text{V}$ | ● | ± 0.2 | ± 1 | ppm/ $^{\circ}\text{C}$ | |
| GNL | Gain Nonlinearity | $V_{\text{OUT}} = \pm 10\text{V}$ | ● | ± 1 | ± 2 ± 3 | ppm ppm | |
| V_{OS} | Input Offset Voltage | $V^- < V_{\text{CMOP}} < V^+ - 1.75\text{V}$ Resistor Divider Ratio = 3.1 Resistor Divider Ratio = 3.1 Resistor Divider Ratio = 8.3 Resistor Divider Ratio = 8.3 Resistor Divider Ratio = 10.3 Resistor Divider Ratio = 10.3 | ● ● ● ● ● | 50 120 160 | 200 600 500 1600 600 2000 | μV μV μV μV μV μV | |
| $\Delta V_{\text{OS}}/\Delta\text{T}$ | Input Offset Voltage Drift (Note 6) | $V^- < V_{\text{CMOP}} < V^+ - 1.75\text{V}$ Resistor Divider Ratio = 3.1 Resistor Divider Ratio = 10.3 | ● ● | 1.5 5 | 4 12 | $\mu\text{V}/^{\circ}\text{C}$ $\mu\text{V}/^{\circ}\text{C}$ | |
| R_{IN} | Input Impedance (Note 8) | Common Mode Resistor Divider Ratio = 3.1 Resistor Divider Ratio = 8.3 Resistor Divider Ratio = 10.3 Differential | ● ● ● ● | 47 36 35 128 | 56 43 42 152 | 65 50 49 176 | k Ω k Ω k Ω k Ω |
| CMRR | Common Mode Rejection Ratio, MS16 Package | Resistor Divider Ratio = 3.1, $V_{\text{CM}} = \pm 28\text{V}$ Resistor Divider Ratio = 8.3, $V_{\text{CM}} = \pm 28\text{V}$ Resistor Divider Ratio = 10.3, $V_{\text{CM}} = \pm 28\text{V}$ | ● ● ● | 90 88 90 88 | 98 98 | dB dB dB dB | |
| CMRR | Common Mode Rejection Ratio, DF14 Package | Resistor Divider Ratio = 3.1, $V_{\text{CM}} = \pm 28\text{V}$ Resistor Divider Ratio = 8.3, $V_{\text{CM}} = \pm 28\text{V}$ Resistor Divider Ratio = 10.3, $V_{\text{CM}} = \pm 28\text{V}$ Resistor Divider Ratio = 10.3, $V_{\text{CM}} = \pm 150\text{V}$, $V_{\text{S}} = \pm 25\text{V}$, $T_A = -40^{\circ}\text{C}$ to 125°C Resistor Divider Ratio = 10.3, $V_{\text{CM}} = \pm 230\text{V}$, $V_{\text{S}} = \pm 25\text{V}$, $T_A = -40^{\circ}\text{C}$ to 85°C | ● ● ● ● ● | 88 86 88 86 88 86 90 86 90 89 | 95 95 | dB dB dB dB dB dB dB dB dB dB | |
| V_{CM} | Input Voltage Range (Note 7) | | ● | -230 | 230 | V | |
| PSRR | Power Supply Rejection Ratio (Input Referred) | $V_{\text{S}} = \pm 1.65\text{V}$ to $\pm 25\text{V}$, $V_{\text{CM}} = V_{\text{OUT}} = \text{Mid-Supply}$ Resistor Divider Ratio = 3.1 Resistor Divider Ratio = 8.3 Resistor Divider Ratio = 10.3 | ● ● ● | 105 98 96 | 120 110 107 | dB dB dB | |
| e_{ni} | Input Referred Noise Voltage Density | $f = 1\text{kHz}$ Resistor Divider Ratio = 3.1 Resistor Divider Ratio = 10.3 | | 105 245 | | $\text{nV}/\sqrt{\text{Hz}}$ $\text{nV}/\sqrt{\text{Hz}}$ | |

ELECTRICAL CHARACTERISTICS The ● denotes the specifications which apply over the full operating temperature range, $-40^{\circ}\text{C} < T_A < 85^{\circ}\text{C}$ for I-grade parts, $-40^{\circ}\text{C} < T_A < 125^{\circ}\text{C}$ for H-grade parts, otherwise specifications are at $T_A = 25^{\circ}\text{C}$, $V^+ = 15\text{V}$, $V^- = -15\text{V}$, $V_{\text{CM}} = V_{\text{OUT}} = V_{\text{REF}} = 0\text{V}$. V_{CMOP} is the common mode voltage of the internal op amp. For Resistor Divider Ratio = 3.1, $\pm\text{REFA} = \pm\text{REFC} = \text{OPEN}$, $\pm\text{REFB} = 0\text{V}$. For Resistor Divider Ratio = 8.3, $\pm\text{REFA} = \pm\text{REFC} = 0\text{V}$, $\pm\text{REFB} = \text{OPEN}$. For Resistor Divider Ratio = 10.3, $\pm\text{REFA} = \pm\text{REFB} = \pm\text{REFC} = 0\text{V}$.

| SYMBOL | PARAMETER | CONDITIONS | MIN | TYP | MAX | UNITS |
|-------------------|--|--|------------------|-------------------|-----------------|--|
| | Input Referred Noise Voltage | $f = 0.1\text{Hz to } 10\text{Hz}$ Resistor Divider Ratio = 3.1 Resistor Divider Ratio = 10.3 | | 4 10 | | $\mu\text{V}_{\text{P-P}}$ $\mu\text{V}_{\text{P-P}}$ |
| V_{OL} | Output Voltage Swing Low (Referred to V^-) | No Load $I_{\text{SINK}} = 5\text{mA}$ | ● ● | 5 280 | 50 500 | mV mV |
| V_{OH} | Output Voltage Swing High (Referred to V^+) | No Load $I_{\text{SOURCE}} = 5\text{mA}$ | ● ● | 5 400 | 20 750 | mV mV |
| I_{SC} | Short-Circuit Output Current | 50Ω to V^+ 50Ω to V^- | ● ● | 10 10 | 28 30 | mA mA |
| SR | Slew Rate | $\Delta V_{\text{OUT}} = \pm 5\text{V}$ | ● | 2.2 | 4.1 | $\text{V}/\mu\text{s}$ |
| BW | Small Signal -3dB Bandwidth | Resistor Divider Ratio = 3.1 Resistor Divider Ratio = 8.3 Resistor Divider Ratio = 10.3 | | 300 190 160 | | kHz kHz kHz |
| t_{S} | Settling Time | Resistor Divider Ratio = 3.1 0.01%, $\Delta V_{\text{OUT}} = 10\text{V}$ 0.1%, $\Delta V_{\text{OUT}} = 10\text{V}$ 0.01%, $\Delta V_{\text{CM}} = 10\text{V}$, $\Delta V_{\text{DIFF}} = 0\text{V}$ | | 41 26 15 | | μs μs μs |
| | | Resistor Divider Ratio = 10.3 0.01%, $\Delta V_{\text{OUT}} = 10\text{V}$ 0.1%, $\Delta V_{\text{OUT}} = 10\text{V}$ 0.01%, $\Delta V_{\text{CM}} = 10\text{V}$, $\Delta V_{\text{DIFF}} = 0\text{V}$ | | 26 16 5 | | μs μs μs |
| V_{S} | Supply Voltage | | ● | 3 3.3 | 50 50 | V V |
| t_{ON} | Turn-On Time | | | 16 | | μs |
| V_{IL} | SHDN Input Logic Low (Referred to V^+) | | ● | | -2.5 | V |
| V_{IH} | SHDN Input Logic High (Referred to V^+) | | ● | -1.2 | | V |
| I_{SHDN} | SHDN Pin Current | | ● | -10 | -15 | μA |
| I_{S} | Supply Current | Active, $V_{\text{SHDN}} \geq V^+ - 1.2\text{V}$ Active, $V_{\text{SHDN}} \geq V^+ - 1.2\text{V}$ Shutdown, $V_{\text{SHDN}} \leq V^+ - 2.5\text{V}$ Shutdown, $V_{\text{SHDN}} \leq V^+ - 2.5\text{V}$ | ● ● ● ● | 350 20 | 400 25 70 | μA μA μA μA |

ELECTRICAL CHARACTERISTICS The ● denotes the specifications which apply over the full operating temperature range, $-40^{\circ}\text{C} < T_A < 85^{\circ}\text{C}$ for I-grade parts, $-40^{\circ}\text{C} < T_A < 125^{\circ}\text{C}$ for H-grade parts, otherwise specifications are at $T_A = 25^{\circ}\text{C}$, $V^+ = 5\text{V}$, $V^- = 0\text{V}$, $V_{\text{CM}} = V_{\text{OUT}} = V_{\text{REF}} = \text{Mid-Supply}$. V_{CMOP} is the common mode voltage of the internal op amp. For Resistor Divider Ratio = 3.1, $\pm\text{REFA} = \pm\text{REFC} = \text{OPEN}$, $\pm\text{REFB} = \text{Mid-Supply}$. For Resistor Divider Ratio = 8.3, $\pm\text{REFA} = \pm\text{REFC} = \text{Mid-Supply}$, $\pm\text{REFB} = \text{OPEN}$. For Resistor Divider Ratio = 10.3, $\pm\text{REFA} = \pm\text{REFB} = \pm\text{REFC} = \text{Mid-Supply}$.

| SYMBOL | PARAMETER | CONDITIONS | MIN | TYP | MAX | UNITS |
|---------------------------------|--|--|-----|-----------------------|--|--|
| G | Gain | $V_{\text{OUT}} = 1\text{V to }4\text{V}$ | | 10 | | V/V |
| ΔG | Gain Error, MS16 Package | $V_{\text{OUT}} = 1\text{V to }4\text{V}$ | | ± 0.002 | ± 0.01 ± 0.012 | % % |
| ΔG | Gain Error, DF14 Package | $V_{\text{OUT}} = 1\text{V to }4\text{V}$ | | ± 0.002 | ± 0.012 ± 0.013 | % % |
| $\Delta G/\Delta T$ | Gain Drift vs Temperature (Note 6) | $V_{\text{OUT}} = 1\text{V to }4\text{V}$ | | ± 0.2 | ± 1 | ppm/ $^{\circ}\text{C}$ |
| GNL | Gain Nonlinearity | $V_{\text{OUT}} = 1\text{V to }4\text{V}$ | | ± 1 | | ppm |
| V_{OS} | Input Offset Voltage | $0 < V_{\text{CMOP}} < V^+ - 1.75\text{V}$ Resistor Divider Ratio = 3.1 Resistor Divider Ratio = 3.1 Resistor Divider Ratio = 8.3 Resistor Divider Ratio = 8.3 Resistor Divider Ratio = 10.3 Resistor Divider Ratio = 10.3 | | 50 120 160 | 200 600 500 1600 600 2000 | μV μV μV μV μV μV |
| $\Delta V_{\text{OS}}/\Delta T$ | Input Offset Voltage Drift (Note 6) | $0 < V_{\text{CMOP}} < V^+ - 1.75\text{V}$ Resistor Divider Ratio = 3.1 Resistor Divider Ratio = 10.3 | | 1.5 5 | 4 12 | $\mu\text{V}/^{\circ}\text{C}$ $\mu\text{V}/^{\circ}\text{C}$ |
| R_{IN} | Input Impedance (Note 8) | Common Mode Resistor Divider Ratio = 3.1 Resistor Divider Ratio = 8.3 Resistor Divider Ratio = 10.3 Differential | | 47 36 35 128 | 56 43 42 152 | $\text{k}\Omega$ $\text{k}\Omega$ $\text{k}\Omega$ $\text{k}\Omega$ |
| CMRR | Common Mode Rejection Ratio, MS16 Package | Resistor Divider Ratio = 3.1 $V_{\text{CM}} = -5.25\text{V to }+4.825\text{V}$ | | 90 87 | 97 | dB dB |
| | | Resistor Divider Ratio = 8.3 $V_{\text{CM}} = -18.25\text{V to }+8.725\text{V}$ | | 90 87 | 97 | dB dB |
| | | Resistor Divider Ratio = 10.3 $V_{\text{CM}} = -23.25\text{V to }+10.225\text{V}$ | | 90 87 | 97 | dB dB |
| CMRR | Common Mode Rejection Ratio, DF14 Package | Resistor Divider Ratio = 3.1 $V_{\text{CM}} = -5.25\text{V to }+4.825\text{V}$ | | 86 85 | 94 | dB dB |
| | | Resistor Divider Ratio = 8.3 $V_{\text{CM}} = -18.25\text{V to }+8.725\text{V}$ | | 86 85 | 94 | dB dB |
| | | Resistor Divider Ratio = 10.3 $V_{\text{CM}} = -23.25\text{V to }+10.225\text{V}$ | | 86 85 | 94 | dB dB |
| PSRR | Power Supply Rejection Ratio (Input Referred) | $V_S = \pm 1.65\text{V to } \pm 25\text{V}$, $V_{\text{CM}} = V_{\text{OUT}} = \text{Mid-Supply}$ Resistor Divider Ratio = 3.1 | | 105 | 120 | dB |
| | | Resistor Divider Ratio = 8.3 | | 98 | 110 | dB |
| | | Resistor Divider Ratio = 10.3 | | 96 | 107 | dB |
| e_{ni} | Input Referred Noise Voltage Density | $f = 1\text{kHz}$ Resistor Divider Ratio = 3.1 Resistor Divider Ratio = 10.3 | | 105 245 | | $\text{nV}/\sqrt{\text{Hz}}$ $\text{nV}/\sqrt{\text{Hz}}$ |
| | Input Referred Noise Voltage | $f = 0.1\text{Hz to }10\text{Hz}$ Resistor Divider Ratio = 3.1 Resistor Divider Ratio = 10.3 | | 4 10 | | $\mu\text{V}_{\text{P-P}}$ $\mu\text{V}_{\text{P-P}}$ |
| V_{OL} | Output Voltage Swing Low (Referred to V^-) | No Load $I_{\text{SINK}} = 5\text{mA}$ | | 5 280 | 50 500 | mV mV |
| V_{OH} | Output Voltage Swing High (Referred to V^+) | No Load $I_{\text{SOURCE}} = 5\text{mA}$ | | 5 400 | 20 750 | mV mV |

6376f

ELECTRICAL CHARACTERISTICS

The ● denotes the specifications which apply over the full operating temperature range, $-40^{\circ}\text{C} < T_A < 85^{\circ}\text{C}$ for I-grade parts, $-40^{\circ}\text{C} < T_A < 125^{\circ}\text{C}$ for H-grade parts, otherwise specifications are at $T_A = 25^{\circ}\text{C}$, $V^+ = 5\text{V}$, $V^- = 0\text{V}$, $V_{\text{CM}} = V_{\text{OUT}} = V_{\text{REF}} = \text{Mid-Supply}$. V_{CMOP} is the common mode voltage of the internal op amp. For Resistor Divider Ratio = 3.1, $\pm\text{REFA} = \pm\text{REFC} = \text{OPEN}$, $\pm\text{REFB} = \text{Mid-Supply}$. For Resistor Divider Ratio = 8.3, $\pm\text{REFA} = \pm\text{REFC} = \text{Mid-Supply}$, $\pm\text{REFB} = \text{OPEN}$. For Resistor Divider Ratio = 10.3, $\pm\text{REFA} = \pm\text{REFB} = \pm\text{REFC} = \text{Mid-Supply}$.

| SYMBOL | PARAMETER | CONDITIONS | MIN | TYP | MAX | UNITS | |
|--|---|--|-----|---------------|------|------------------|--|
| I_{SC} | Short-Circuit Output Current | 50Ω to V^+ | ● | 10 | 27 | mA | |
| | | 50Ω to V^- | ● | 10 | 25 | mA | |
| SR | Slew Rate | $\Delta V_{\text{OUT}} = 3\text{V}$ | ● | 1.9 | 3 | V/ μs | |
| BW | Small Signal -3dB Bandwidth | Resistor Divider Ratio = 3.1 | | 300 | | kHz | |
| | | Resistor Divider Ratio = 8.3 | | 190 | | kHz | |
| | | Resistor Divider Ratio = 10.3 | | 160 | | kHz | |
| t_{S} | Settling Time | Resistor Divider Ratio = 3.1 | | | | | |
| | | 0.01%, $\Delta V_{\text{OUT}} = 2\text{V}$ | | 34 | | μs | |
| | | 0.1%, $\Delta V_{\text{OUT}} = 2\text{V}$ | | 20 | | μs | |
| | | 0.01%, $\Delta V_{\text{CM}} = 2\text{V}$, $\Delta V_{\text{DIFF}} = 0\text{V}$ | | 10 | | μs | |
| | | Resistor Divider Ratio = 10.3 | | | | | |
| | | 0.01%, $\Delta V_{\text{OUT}} = 2\text{V}$ | | 40 | | μs | |
| 0.1%, $\Delta V_{\text{OUT}} = 2\text{V}$ | | 16 | | μs | | | |
| 0.01%, $\Delta V_{\text{CM}} = 2\text{V}$, $\Delta V_{\text{DIFF}} = 0\text{V}$ | | 5 | | μs | | | |
| V_{S} | Supply Voltage | | ● | 3 | 50 | V | |
| | | | | 3.3 | 50 | V | |
| t_{ON} | Turn-On Time | | | 22 | | μs | |
| V_{IL} | SHDN Input Logic Low (Referred to V^+) | | ● | | -2.5 | V | |
| V_{IH} | SHDN Input Logic High (Referred to V^+) | | ● | -1.2 | | V | |
| I_{SHDN} | SHDN Pin Current | | ● | -10 | -15 | μA | |
| I_{S} | Supply Current | Active, $V_{\text{SHDN}} \geq V^+ - 1.2\text{V}$ | ● | 330 | 370 | μA | |
| | | Active, $V_{\text{SHDN}} \geq V^+ - 1.2\text{V}$ | ● | | 525 | μA | |
| | | Shutdown, $V_{\text{SHDN}} \leq V^+ - 2.5\text{V}$ | ● | 15 | 20 | μA | |
| | | Shutdown, $V_{\text{SHDN}} \leq V^+ - 2.5\text{V}$ | ● | | 40 | μA | |

Note 1: Stresses beyond those listed under Absolute Maximum Ratings may cause permanent damage to the device. Exposure to any Absolute Maximum Rating condition for extended periods may affect device reliability and lifetime.

Note 2: See Common Mode Voltage Range in the Applications Information section of this data sheet for other considerations when taking $+I_{\text{IN}}/I_{\text{IN}}$ pins to $\pm 240\text{V}$. All other pins should not be taken more than 0.3V beyond the supply rails.

Note 3: A heat sink may be required to keep the junction temperature below absolute maximum. This depends on the power supply, input voltages and the output current.

Note 4: The LT6376I is guaranteed functional over the operating temperature range of -40°C to 85°C . The LT6376H is guaranteed functional over the operating temperature range of -40°C to 125°C .

Note 5: The LT6376I is guaranteed to meet specified performance from -40°C to 85°C . The LT6376H is guaranteed to meet specified performance from -40°C to 125°C .

Note 6: This parameter is not 100% tested.

Note 7: Input voltage range is guaranteed by the CMRR test at $V_{\text{S}} = \pm 25\text{V}$ and all REF pins at ground (Resistor Divider Ratio = 10.3). For the other voltages, this parameter is guaranteed by design and through correlation with the $\pm 25\text{V}$ test. See Common Mode Voltage Range in the Applications Information section to determine the valid input voltage range under various operating conditions.

Note 8: Input impedance is tested by a combination of direct measurement and correlation to the CMRR and gain error tests.

TYPICAL PERFORMANCE CHARACTERISTICS $T_A = 25^\circ\text{C}$, $V_S = \pm 15\text{V}$, unless otherwise noted.

Typical Distribution of CMRR

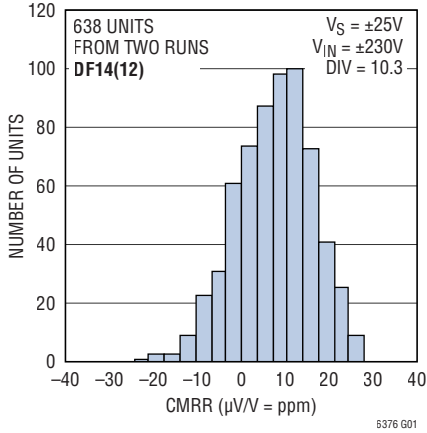

Typical Distribution of CMRR

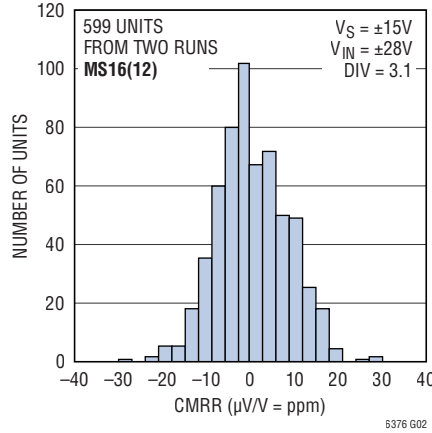

Typical Distribution of CMRR

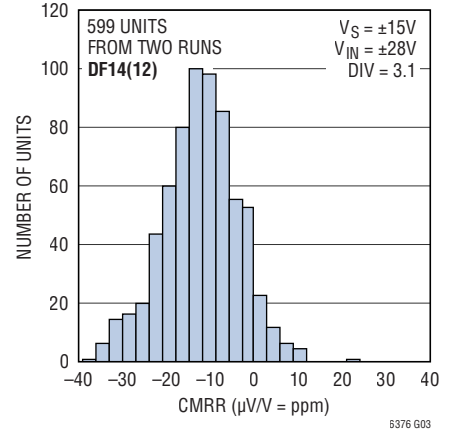

Typical Distribution of Gain Error

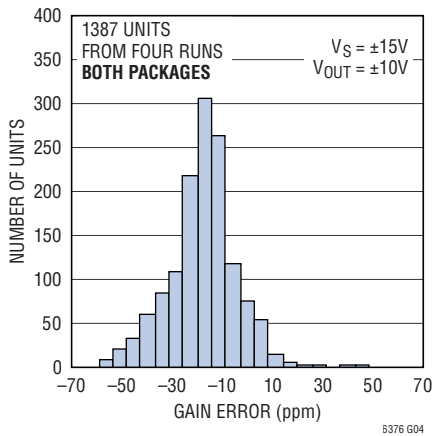

Typical Distribution of Gain Error

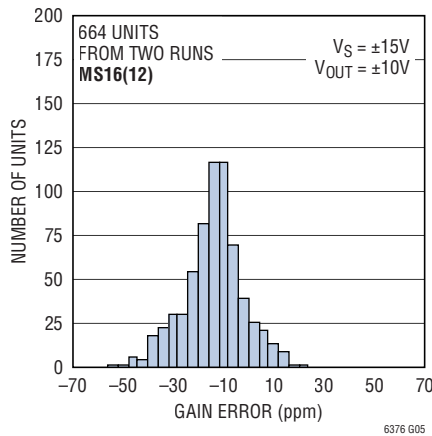

Typical Distribution of Gain Error

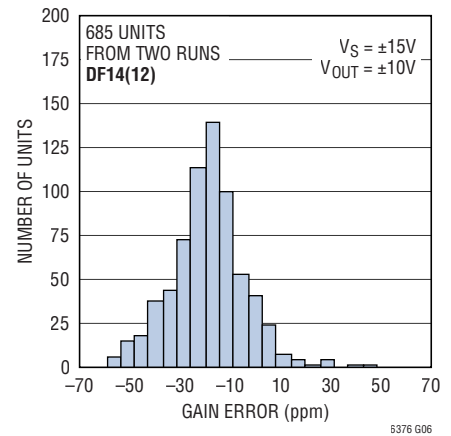

Typical Distribution of Gain Nonlinearity

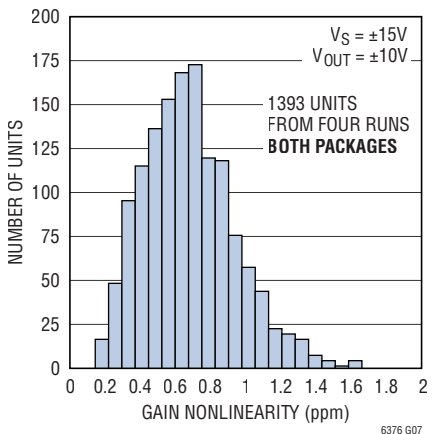

Typical Distribution of Input Offset Voltage

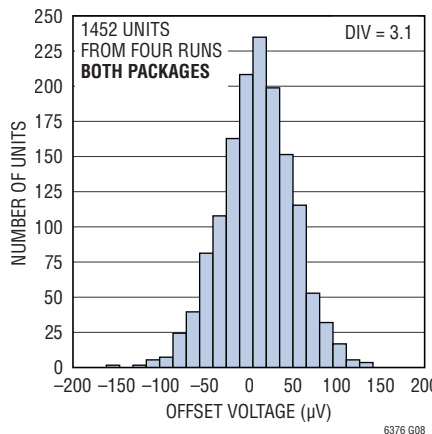

Typical Distribution of Input Offset Voltage

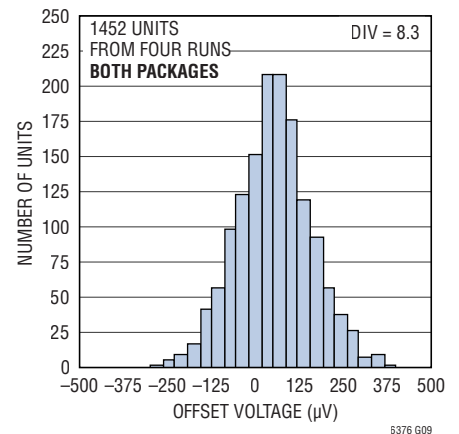

TYPICAL PERFORMANCE CHARACTERISTICS $T_A = 25^\circ\text{C}$, $V_S = \pm 15\text{V}$, unless otherwise noted.

Typical Distribution of Input Offset Voltage

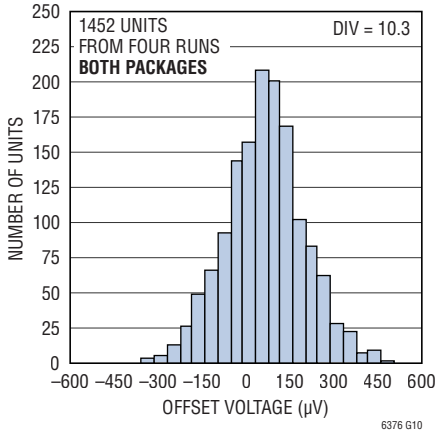

Typical Distribution of PSRR (Input Referred)

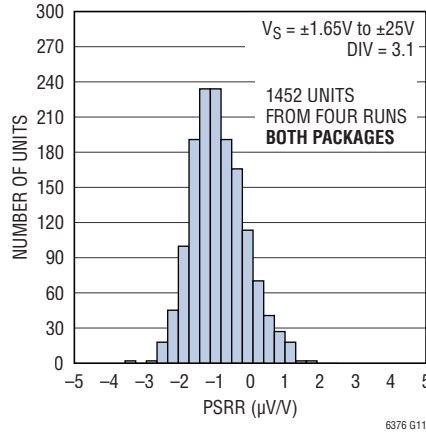

Typical Distribution of PSRR (Input Referred)

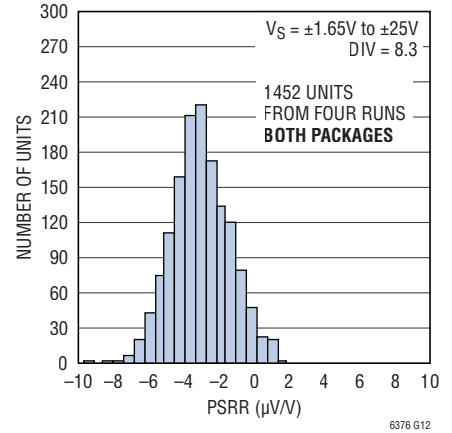

Typical Distribution of PSRR (Input Referred)

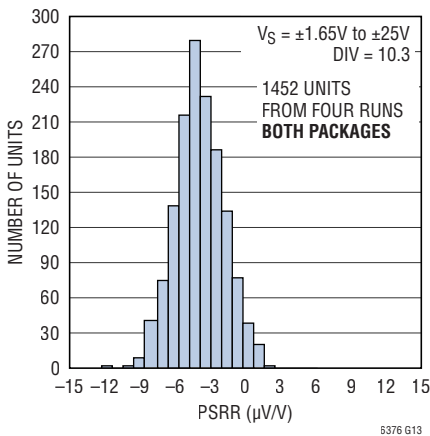

CMRR vs Frequency

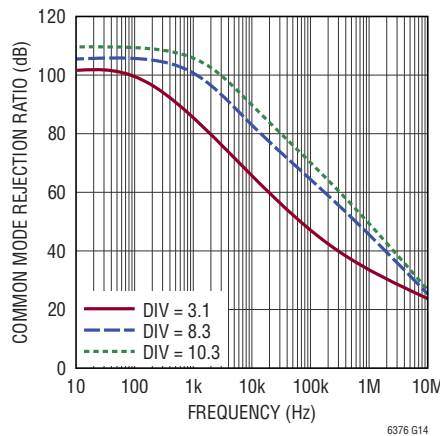

Common Mode Voltage Range vs Power Supply Voltage

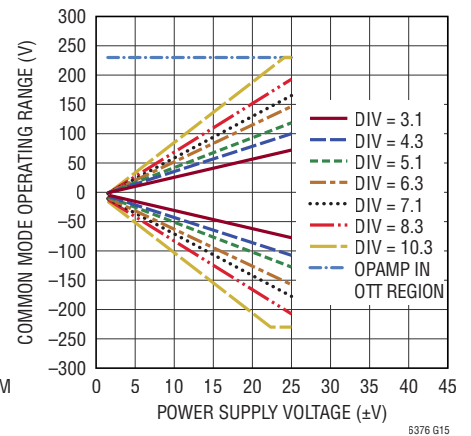

Typical Gain Error for $R_L = 10\text{k}\Omega$ (Curves Offset for Clarity)

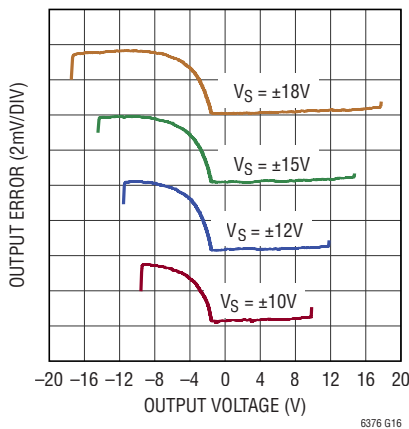

Typical Gain Error for $R_L = 2\text{k}\Omega$ (Curves Offset for Clarity)

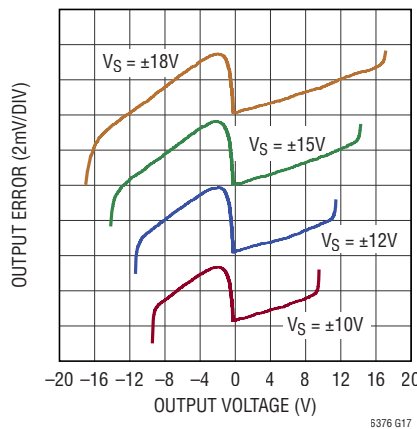

Typical Gain Error for Low Supply Voltages (Curves Offset for Clarity)

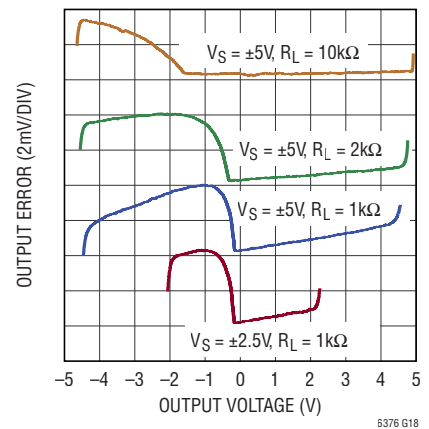

TYPICAL PERFORMANCE CHARACTERISTICS $T_A = 25^\circ\text{C}$, $V_S = \pm 15\text{V}$, unless otherwise noted.

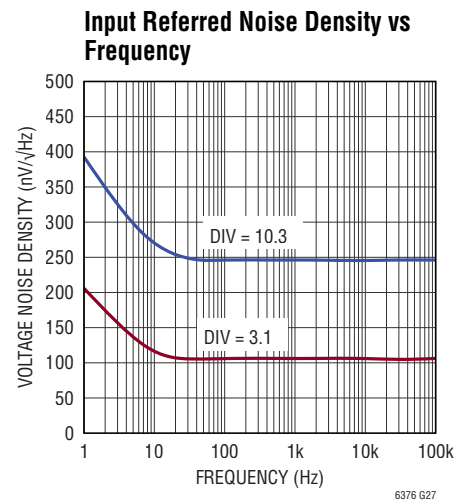
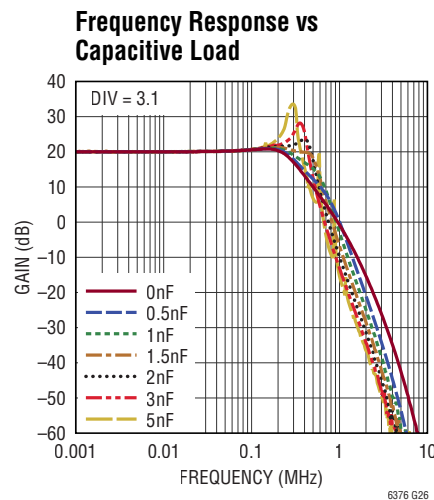
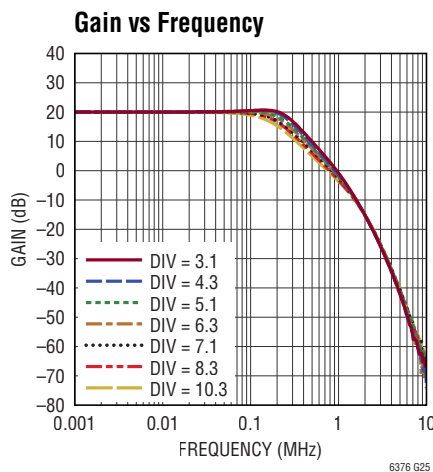
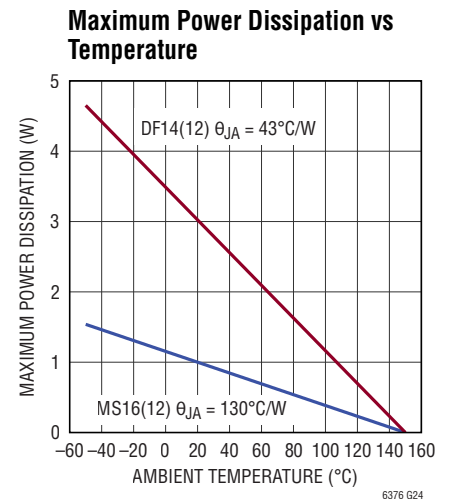
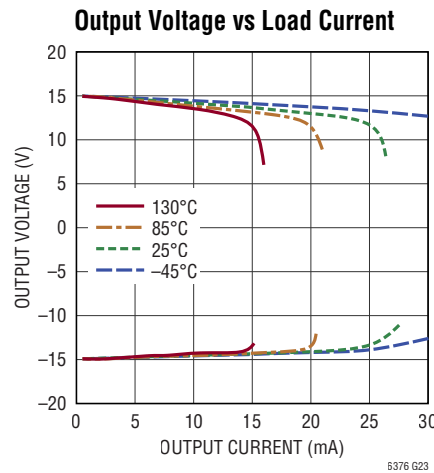
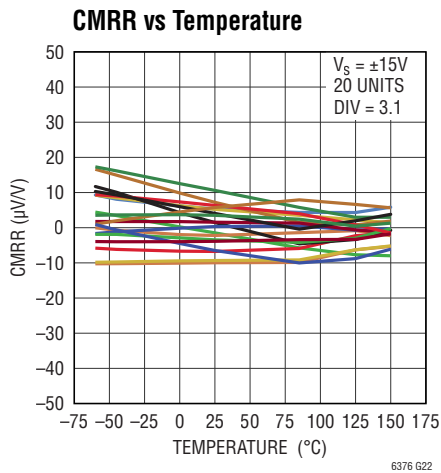
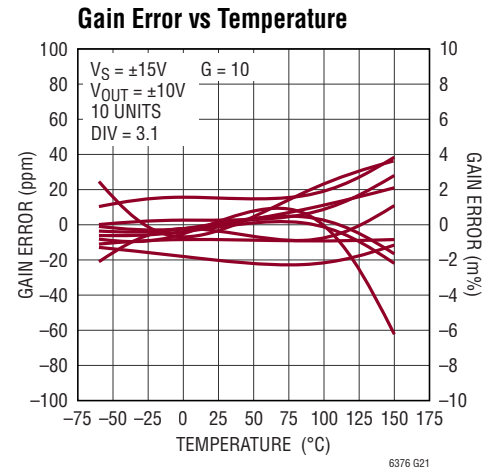
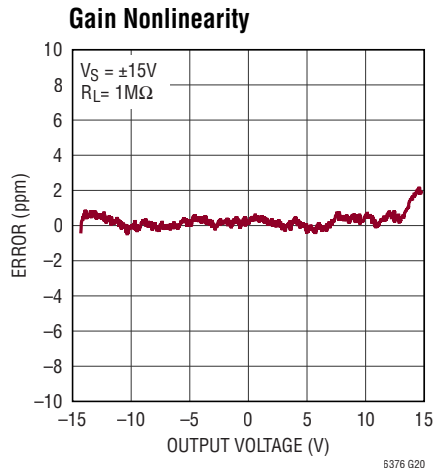
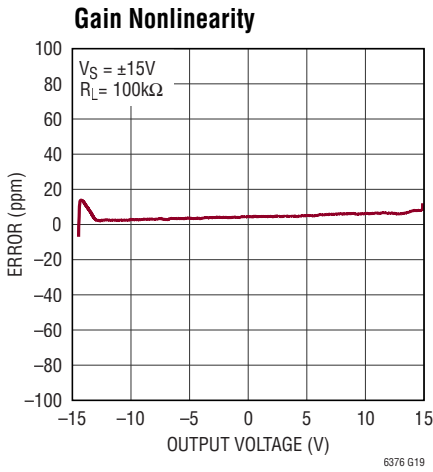

TYPICAL PERFORMANCE CHARACTERISTICS $T_A = 25^\circ\text{C}$, $V_S = \pm 15\text{V}$, unless otherwise noted.

0.1Hz to 10Hz Noise (Input Referred)

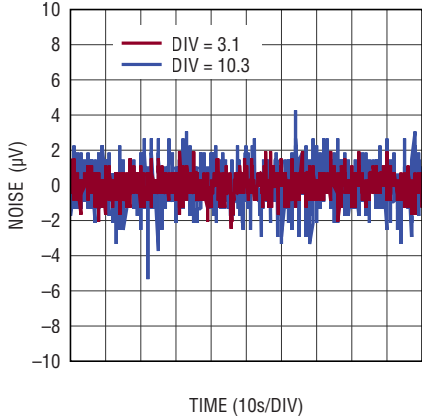

6376 G28

Positive PSRR vs Frequency

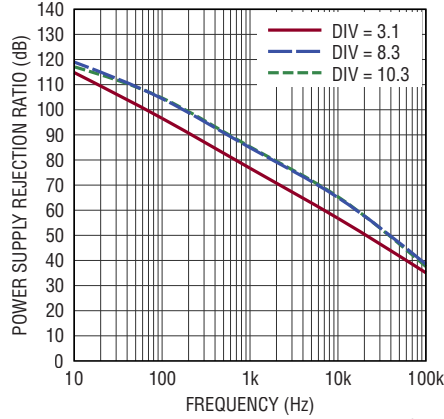

6376 G29

Negative PSRR vs Frequency

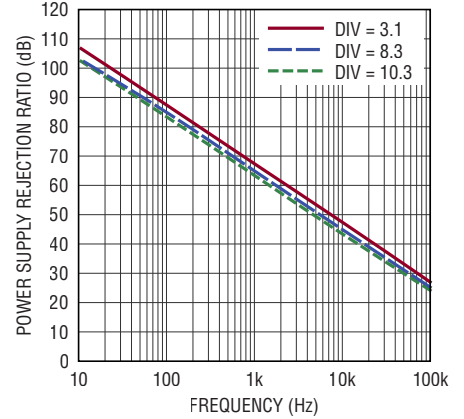

6376 G30

Slew Rate vs Temperature

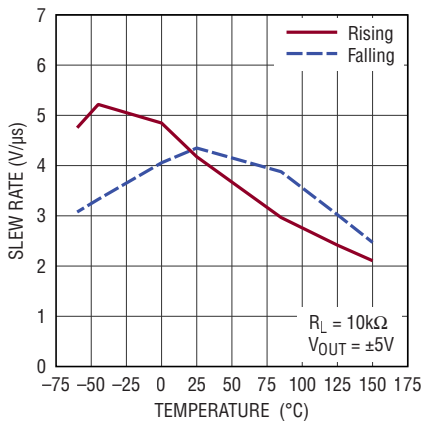

6376 G31

Large-Signal Step Response

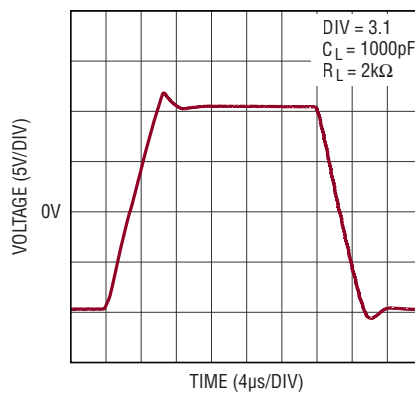

6376 G32

Small-Signal Step Response

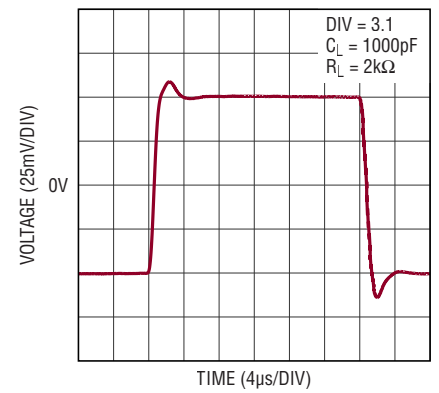

6376 G33

Small-Signal Step Response vs Capacitive Load

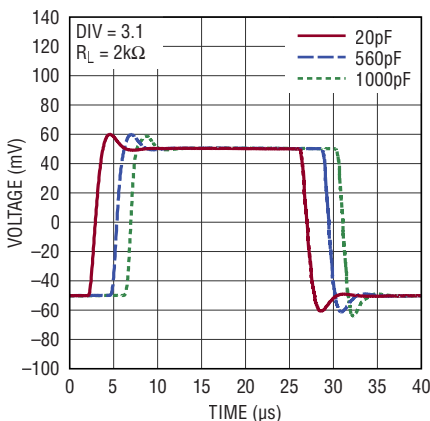

6376 G34

Large-Signal Step Response

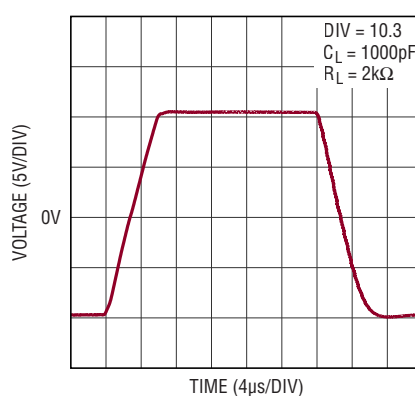

6376 G35

Small-Signal Step Response

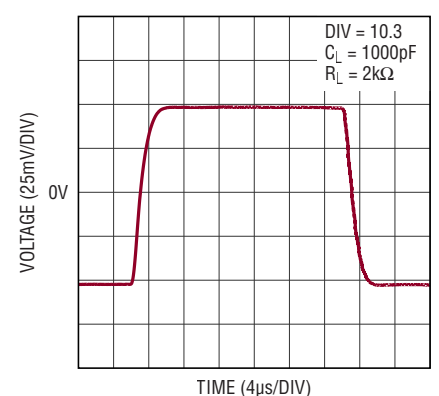

6376 G36

TYPICAL PERFORMANCE CHARACTERISTICS $T_A = 25^\circ\text{C}$, $V_S = \pm 15\text{V}$, unless otherwise noted.

Small-Signal Step Response vs Capacitive Load

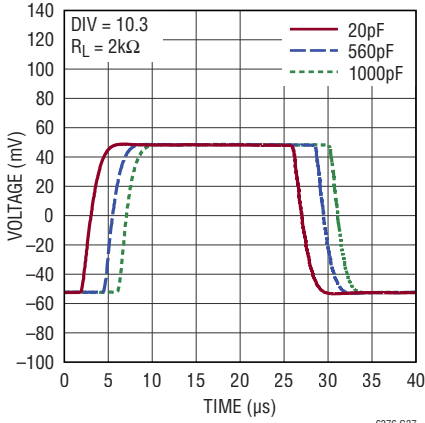

Settling Time

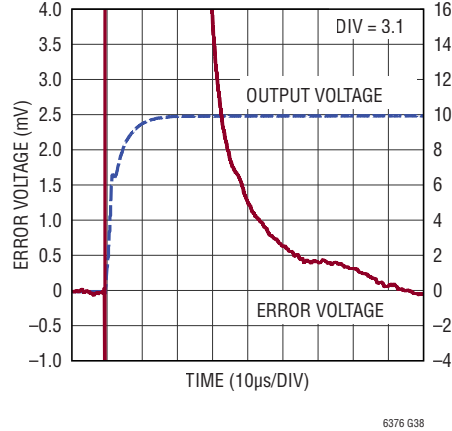

Settling Time

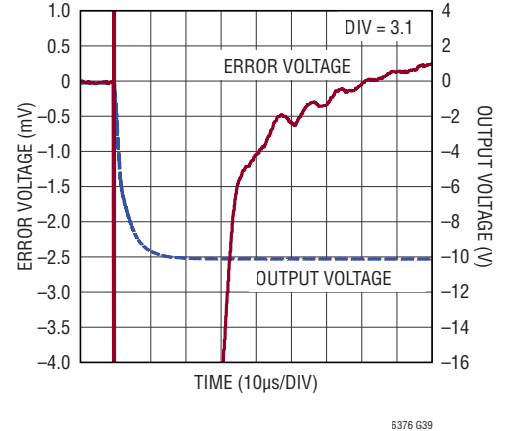

Input Common Mode Step Response

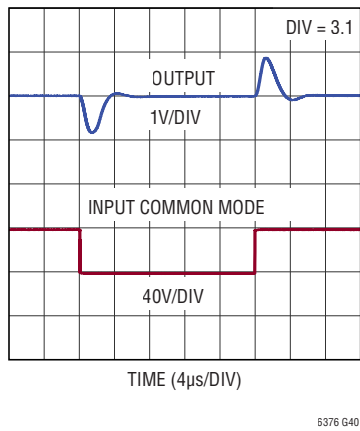

Input Offset Voltage vs Temperature

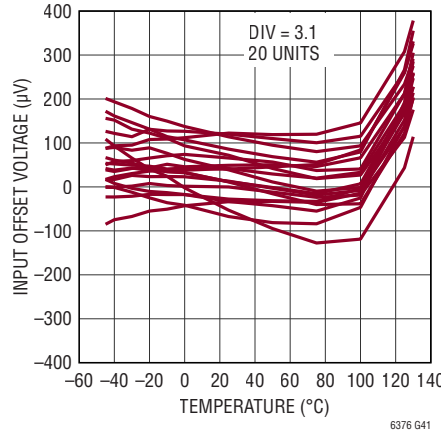

Quiescent Current vs Temperature

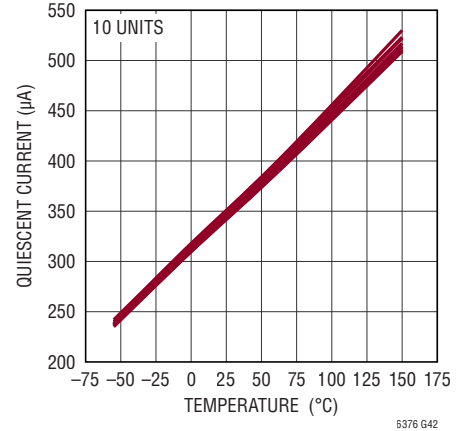

Thermal Shutdown Hysteresis

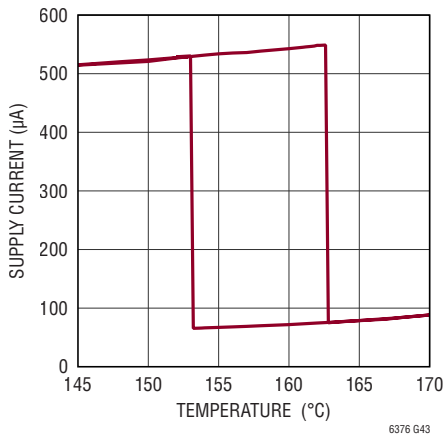

Quiescent Current vs Supply Voltage

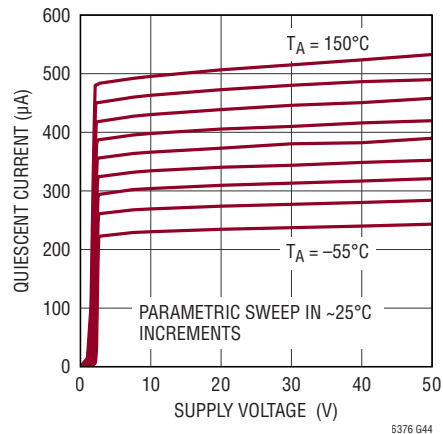

TYPICAL PERFORMANCE CHARACTERISTICS $T_A = 25^\circ\text{C}$, $V_S = \pm 15\text{V}$, unless otherwise noted.

Shutdown Quiescent Current vs Supply Voltage

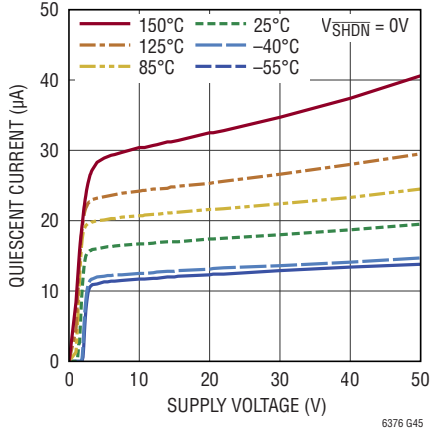

6376 G45

Quiescent Current vs SHDN Voltage

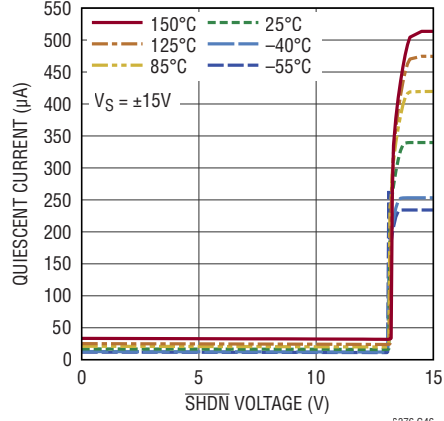

6376 G46

Minimum Supply Voltage

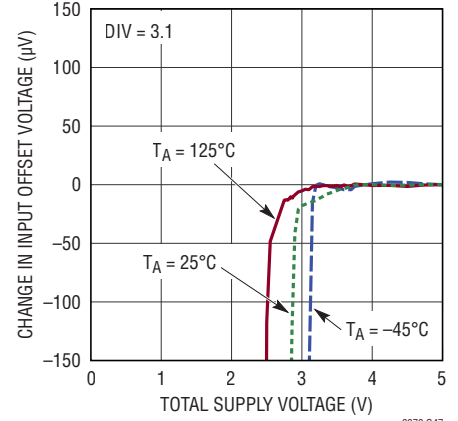

6376 G47

PIN FUNCTIONS (DFN/MSOP)

V⁺ (Pin 9/Pin 10): Positive Supply Pin.

V⁻ (Exposed Pad Pin 15/Pin 8): Negative Supply Pin.

OUT (Pin 8/Pin 9): Output Pin.

+IN (Pin 1/Pin 1): Noninverting Input Pin. Accepts input voltages from 230V to -230V.

+REFA (Pin 3/Pin 3): Reference Pin A. Sets the input common mode range and the output noise and offset.

+REFB (Pin 4/Pin 5): Reference Pin B. Sets the input common mode range and the output noise and offset.

+REFC (Pin 5/Pin 6): Reference Pin C. Sets the input common mode range and the output noise and offset.

-IN (Pin 14/Pin 16): Inverting Input Pin. Accepts input voltages from 230V to -230V.

-REFA (Pin 12/Pin 14): Reference Pin A. Sets the input common mode range and the output noise and offset.

-REFB (Pin 11/Pin 12): Reference Pin B. Sets the input common mode range and the output noise and offset.

-REFC (Pin 10/Pin 11): Reference Pin C. Sets the input common mode range and the output noise and offset.

REF (Pin 6/Pin 7): Reference Input. Sets the output level when the difference between the inputs is zero.

SHDN (Pin 7) DFN Only: Shutdown Pin. Amplifier is active when this pin is tied to V⁺ or left floating. Pulling the pin >2.5V below V⁺ causes the amplifier to enter a low power state.

BLOCK DIAGRAM

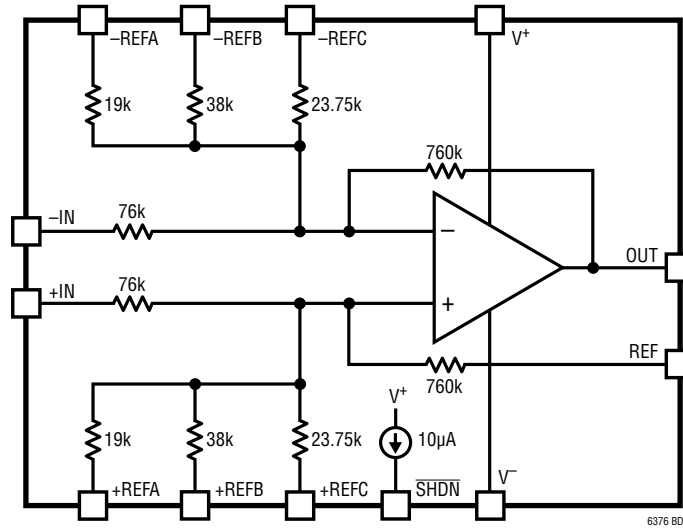

APPLICATIONS INFORMATION

TRANSFER FUNCTION

The LT6376 is a gain of 10 difference amplifier with the transfer function:

$$V_{OUT} = 10 \cdot (V_{+IN} - V_{-IN}) + V_{REF}$$

The voltage on the REF pin sets the output voltage when the differential input voltage ($V_{DIFF} = V_{+IN} - V_{-IN}$) is zero. This reference is used to shift the output voltage to the desired input level of the next stage of the signal chain.

BENEFITS OF SELECTABLE RESISTOR DIVIDER RATIOS

The LT6376 offers smaller package size, better gain accuracy and better noise performance than existing high common mode voltage range difference amplifiers. Additionally, the LT6376 allows users to maximize system performance by selecting the resistor divider ratio (DIV) appropriate to their input common mode voltage range. A higher resistor divider ratio (DIV) enables a higher common mode voltage range at the input pins, but it also increases output noise and output offset/drift and decreases the -3dB bandwidth. Therefore, a trade-off exists between input range and DC, AC, and drift

performance of the part. It is recommended to use the lowest resistor divider ratio that achieves the required input common mode voltage range of the application in order to maximize the system SNR, precision and speed.

Table 1 shows the noise, offset/drift, and -3dB bandwidth of the LT6376 in gain of 10 configurations.

COMMON MODE VOLTAGE RANGE

The wide common mode voltage range of the LT6376 is enabled by both a resistor divider at the input of the op amp and by an internal op amp that can withstand high input voltages.

The internal resistor network of the LT6376 divides down the input common mode voltage. The resulting voltage at the op amp inputs determines the op amp's operating region. In the configuration shown in Figure 1, a resistor divider is created at both op amp inputs by the 76k input resistor and the resistance from each input to ground, which is $\sim 36.19\text{k}$. The resistance to ground is formed by the 38k (REFB resistors) in parallel with the 760k (feedback/REF resistor). The result is a divide by 3.1 of the input voltage. As shown in Tables 1 to 5, different connections to reference pins (i.e. pins +REFA, -REFA,

APPLICATIONS INFORMATION

Table 1. LT6376 Performance at Different Resistor Divider Ratios

| RESISTOR DIVIDER OPTIONS | | | | RESISTOR DIVIDER RATIO (DIV) | DIFFERENTIAL GAIN | INPUT NOISE AT 1kHz (nV/√Hz) | MAXIMUM INPUT OFFSET (μV) | MAXIMUM INPUT OFFSET DRIFT (μV/°C) | -3dB BANDWIDTH (kHz) |
|--------------------------|-----------------|-----------------|------|------------------------------|-------------------|------------------------------|---------------------------|------------------------------------|----------------------|
| +REFA AND -REFA | +REFB AND -REFB | +REFC AND -REFC | REF | | | | | | |
| 19k | 38k | 23.75k | 760k | | | | | | |
| OPEN | GND | OPEN | REF | 3.1 | 10 | 105 | 200 | 4 | 300 |
| OPEN | OPEN | GND | REF | 4.3 | 10 | 130 | 250 | 5.5 | 275 |
| GND | OPEN | OPEN | REF | 5.1 | 10 | 145 | 300 | 6.5 | 245 |
| OPEN | GND | GND | REF | 6.3 | 10 | 170 | 380 | 7.5 | 225 |
| GND | GND | OPEN | REF | 7.1 | 10 | 185 | 420 | 8.5 | 200 |
| GND | OPEN | GND | REF | 8.3 | 10 | 210 | 500 | 10 | 190 |
| GND | GND | GND | REF | 10.3 | 10 | 245 | 600 | 12 | 160 |

+REFB, -REFB, +REFC, -REFC) result in different resistor divider ratios (DIV) and different attenuation of the LT6376’s input common mode voltage.

The internal op amp of LT6376 has two operating regions: a) If the common mode voltage at the inputs of the internal op amp (V_{CMOP}) is between V^- and $V^+ - 1.75V$, the op amp operates in its normal region; b) If V_{CMOP} is between $V^+ - 1.75V$ and $V^- + 76V$, the op amp continues to operate, but in its Over-The-Top region with degraded performance (see Over-The-Top operation section of this data sheet for more detail).

Table 2 lists the valid input common mode voltage range for an LT6376 with different configurations of the reference pins when used with dual power supplies. Using

the voltage ranges in this table ensures that the internal op amp is operating in its normal (and best) region. The figure entitled Common Mode Voltage Range vs Power Supply Voltage, in the Typical Performance Characteristics section of this data sheet, illustrates the information in Table 2 graphically.

Table 3 lists the valid input common mode voltage range for an LT6376 that results in the internal op amp operating in its Over-The-Top region.

The reference pins can be connected to ground (as in Tables 2 and 3) or to any reference voltage. In order to achieve the specified gain accuracy and CMRR performance of the LT6376, this reference must have a very low impedance over the entire bandwidth of interest. As needed, ensure there are quality high frequency ceramic or film capacitors and low frequency electrolytic capacitors, from the reference to ground.

The valid input common mode range changes depending on the voltages chosen for reference pins. Table 4 lists the valid input common mode voltage range for an LT6376 when the part is used with a single power supply, and REF and the other reference pins are connected to mid-supply. If, as shown in Table 5, the REF pin remains connected to mid-supply, while the other reference pins are connected to ground, the result is a higher positive input range at the expense of a more restricted negative input range.

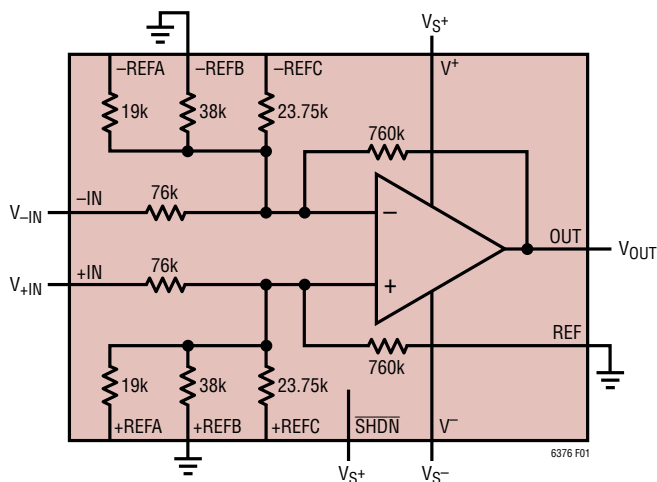

Figure 1. Basic Connections for Dual-Supply Operation (Resistor Divider Ratio = 3.1)

APPLICATIONS INFORMATION

Table 2. Common Mode Voltage Operating Range with Dual Power Supplies (Normal Region)

| INPUT RANGE (REF = GND) | | | | | | | | | | |
|-------------------------|-----------------------|-----------------------|------|------------------|--------|-----------------|--------|-----------------|--------|--|
| +REFA AND -REFA | +REFB AND -REFB | +REFC AND -REFC | DIV | $V_S = \pm 2.5V$ | | $V_S = \pm 15V$ | | $V_S = \pm 25V$ | | |
| | | | | HIGH | LOW | HIGH | LOW | HIGH | LOW | |
| OPEN | GND | OPEN | 3.1 | 2.325 | -7.75 | 41.075 | -46.5 | 72.075 | -77.5 | |
| OPEN | OPEN | GND | 4.3 | 3.225 | -10.75 | 56.975 | -64.5 | 99.975 | -107.5 | |
| GND | OPEN | OPEN | 5.1 | 3.825 | -12.75 | 67.575 | -76.5 | 118.575 | -127.5 | |
| OPEN | GND | GND | 6.3 | 4.725 | -15.75 | 83.475 | -94.5 | 146.475 | -157.5 | |
| GND | GND | OPEN | 7.1 | 5.325 | -17.75 | 94.075 | -106.5 | 165.075 | -177.5 | |
| GND | OPEN | GND | 8.3 | 6.225 | -20.75 | 109.975 | -124.5 | 192.975 | -207.5 | |
| GND | GND | GND | 10.3 | 7.725 | -25.75 | 136.475 | -154.5 | 230 | -230 | |

Table 3. Common Mode Voltage Operating Range with Dual Power Supplies (Over-The-Top Region)

| INPUT RANGE (REF = GND) | | | | | | | | | | |
|-------------------------|-----------------------|-----------------------|------|------------------|--------|-----------------|--------|-----------------|--------|--|
| +REFA AND -REFA | +REFB AND -REFB | +REFC AND -REFC | DIV | $V_S = \pm 2.5V$ | | $V_S = \pm 15V$ | | $V_S = \pm 25V$ | | |
| | | | | HIGH | LOW | HIGH | LOW | HIGH | LOW | |
| OPEN | GND | OPEN | 3.1 | 227.85 | -7.75 | 189.1 | -46.5 | 158.1 | -77.5 | |
| OPEN | OPEN | GND | 4.3 | 230 | -10.75 | 230 | -64.5 | 219.3 | -107.5 | |
| GND | OPEN | OPEN | 5.1 | 230 | -12.75 | 230 | -76.5 | 230 | -127.5 | |
| OPEN | GND | GND | 6.3 | 230 | -15.75 | 230 | -94.5 | 230 | -157.5 | |
| GND | GND | OPEN | 7.1 | 230 | -17.75 | 230 | -106.5 | 230 | -177.5 | |
| GND | OPEN | GND | 8.3 | 230 | -20.75 | 230 | -124.5 | 230 | -207.5 | |
| GND | GND | GND | 10.3 | 230 | -25.75 | 230 | -154.5 | 230 | -230 | |

Table 4. Common Mode Voltage Operating Range with a Single Power Supply, References to Mid-Supply (Normal Region)

| INPUT RANGE (REF = $V_S/2$) | | | | | | | | | | |
|------------------------------|-----------------------|-----------------------|------|------------|--------|-------------|--------|-------------|--------|--|
| +REFA AND -REFA | +REFB AND -REFB | +REFC AND -REFC | DIV | $V_S = 5V$ | | $V_S = 30V$ | | $V_S = 50V$ | | |
| | | | | HIGH | LOW | HIGH | LOW | HIGH | LOW | |
| OPEN | $V_S/2$ | OPEN | 3.1 | 4.825 | -5.25 | 56.075 | -31.5 | 97.075 | -52.5 | |
| OPEN | OPEN | $V_S/2$ | 4.3 | 5.725 | -8.25 | 71.975 | -49.5 | 124.975 | -82.5 | |
| $V_S/2$ | OPEN | OPEN | 5.1 | 6.325 | -10.25 | 82.575 | -61.5 | 143.575 | -102.5 | |
| OPEN | $V_S/2$ | $V_S/2$ | 6.3 | 7.225 | -13.25 | 98.475 | -79.5 | 171.475 | -132.5 | |
| $V_S/2$ | $V_S/2$ | OPEN | 7.1 | 7.825 | -15.25 | 109.075 | -91.5 | 190.075 | -152.5 | |
| $V_S/2$ | OPEN | $V_S/2$ | 8.3 | 8.725 | -18.25 | 124.975 | -109.5 | 217.975 | -182.5 | |
| $V_S/2$ | $V_S/2$ | $V_S/2$ | 10.3 | 10.225 | -23.25 | 151.475 | -139.5 | 230 | -230 | |

Table 5. Common Mode Voltage Operating Range with a Single Power Supply, References to GND (Normal Region)

| INPUT RANGE (REF = $V_S/2$) | | | | | | | | | | |
|------------------------------|-----------------------|-----------------------|------|------------|-------|-------------|------|-------------|------|--|
| +REFA AND -REFA | +REFB AND -REFB | +REFC AND -REFC | DIV | $V_S = 5V$ | | $V_S = 30V$ | | $V_S = 50V$ | | |
| | | | | HIGH | LOW | HIGH | LOW | HIGH | LOW | |
| OPEN | GND | OPEN | 3.1 | 9.825 | -0.25 | 86.075 | -1.5 | 147.075 | -2.5 | |
| OPEN | OPEN | GND | 4.3 | 13.725 | -0.25 | 119.975 | -1.5 | 204.975 | -2.5 | |
| GND | OPEN | OPEN | 5.1 | 16.325 | -0.25 | 142.575 | -1.5 | 230 | -2.5 | |
| OPEN | GND | GND | 6.3 | 20.225 | -0.25 | 176.475 | -1.5 | 230 | -2.5 | |
| GND | GND | OPEN | 7.1 | 22.825 | -0.25 | 199.075 | -1.5 | 230 | -2.5 | |
| GND | OPEN | GND | 8.3 | 26.725 | -0.25 | 230 | -1.5 | 230 | -2.5 | |
| GND | GND | GND | 10.3 | 33.225 | -0.25 | 230 | -1.5 | 230 | -2.5 | |

The LT6376 will not operate correctly if the common mode voltage at its input pins goes below the range specified in above tables, but the part will not be damaged as long as the lowest common mode voltage at the inputs of the internal op amp (V_{CMOP}) is always greater than $V^- - 25V$. Also, the voltage at LT6376 input pins should never be higher than 230V or lower than -230V under any circumstances.

SHUTDOWN

The LT6376 in the DFN14 package has a shutdown pin (SHDN). Under normal operation this pin should be tied to V^+ or allowed to float. Driving this pin to at least 2.5V below V^+ will cause the part to enter a low power state. The supply current is reduced to less than 25 μ A and the op amp output becomes high impedance.

SUPPLY VOLTAGE

The positive supply pin of the LT6376 should be bypassed with a small capacitor (typically 0.1 μ F) as close to the supply pin as possible. When driving heavy loads an additional 4.7 μ F electrolytic capacitor should be added. When using split supplies, the same is true for the V^- supply pin.

APPLICATIONS INFORMATION

ACCURATE CURRENT MEASUREMENTS

The LT6376 can be used in high side, low side and bi-directional wide common mode range current sensing. Figure 2 shows the LT6376 sensing current by measuring the voltage across R_{SENSE} . The added sense resistors create a CMRR error and a gain error. For R_{SENSE} greater than 0.5Ω the source resistance mismatch degrades the CMRR. Adding a resistor equal in value to R_{SENSE} in series with the +IN terminal (R_C) eliminates this mismatch.

Using an R_{SENSE} greater than 4.7Ω will cause the gain error to exceed the 0.0075% specification of the LT6376. This is due to the loading effects of the LT6376.

$$V_{OUT} = 10 \cdot I_{LOAD} \cdot R_{SENSE} \cdot 76k / (76k + R_{SENSE})$$

Increasing R_{SENSE} and R_C slightly to R_{SENSE}' removes the gain error.

$$R_{SENSE}' = R_{SENSE} \cdot 76k / (76k - R_{SENSE})$$

NOISE AND FILTERING

The noise performance of the LT6376 can be optimized both by appropriate choice of its internal attenuation setting and by the addition of a filter to the amplifier output (Figure 3). For applications that do not require the full bandwidth of the LT6376, the addition of an output filter will lower system noise. Table 6 shows the output noise for different internal resistor divider ratios and output filter bandwidths.

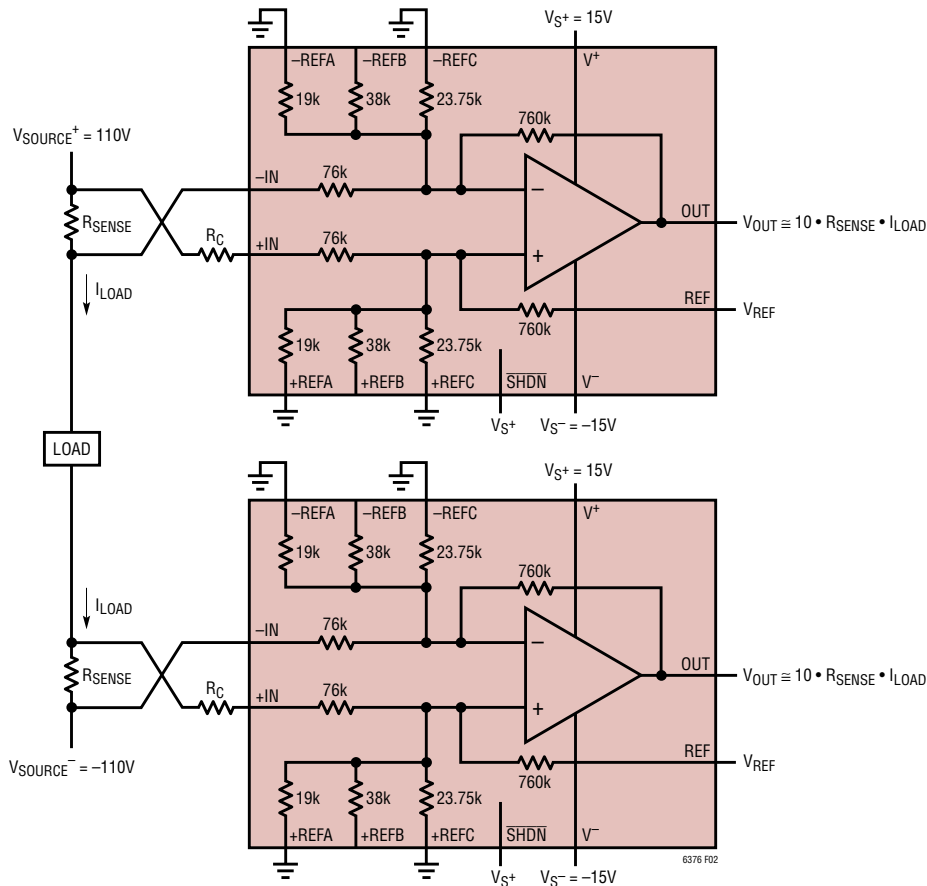

Figure 2. Wide Voltage Range Current Sensing

APPLICATIONS INFORMATION

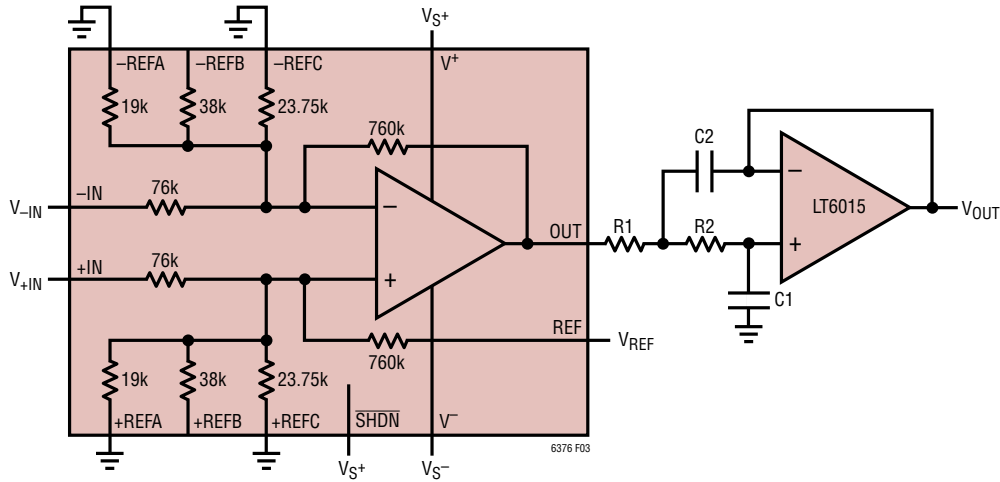

Figure 3. Output Filtering with 2-Pole Butterworth Filter

Table 6. Output Noise ($V_{p,p}$) for 2-Pole Butterworth Filter for Different Internal Resistor Divider Ratios

| Corner Frequency | 3.1 | 4.3 | 5.1 | 6.3 | 7.1 | 8.3 | 10.3 |
|------------------|-------------|-------------|-------------|-------------|-------------|-------------|-------------|
| No Filter | 548 μ V | 606 μ V | 638 μ V | 678 μ V | 707 μ V | 747 μ V | 809 μ V |
| 100kHz | 328 μ V | 394 μ V | 434 μ V | 488 μ V | 523 μ V | 572 μ V | 649 μ V |
| 10kHz | 107 μ V | 131 μ V | 146 μ V | 168 μ V | 183 μ V | 204 μ V | 239 μ V |
| 1kHz | 33 μ V | 41 μ V | 46 μ V | 53 μ V | 57 μ V | 64 μ V | 75 μ V |
| 100Hz | 12 μ V | 15 μ V | 17 μ V | 19 μ V | 21 μ V | 24 μ V | 28 μ V |

Table 7. Component Values for Different 2-Pole Butterworth Filter Bandwidths

| Corner Frequency | R1 | R2 | C1 | C2 |
|------------------|--------------|----------------|-------------|-------------|
| 100kHz | 11k Ω | 11.3k Ω | 100pF | 200pF |
| 10kHz | 11k Ω | 11.3k Ω | 1nF | 2nF |
| 1kHz | 11k Ω | 11.3k Ω | 10nF | 20nF |
| 100Hz | 11k Ω | 11.3k Ω | 0.1 μ F | 0.2 μ F |

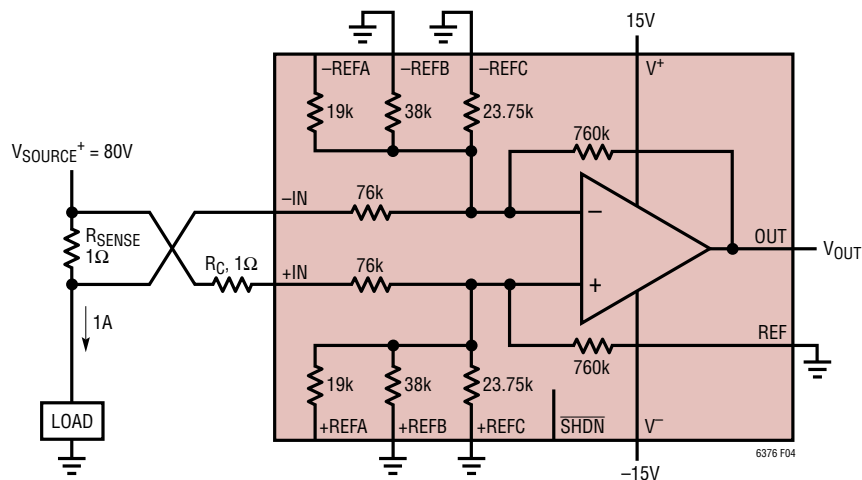

Figure 4. Current Measurement Application

APPLICATIONS INFORMATION

ERROR BUDGET ANALYSIS

Figure 4 shows the LT6376 in a current measurement application. The error budget for this application is shown in Table 8. The resistor divider ratio is set to 6.3 to divide the 80V input common mode voltage down to 12.7V at the op amp inputs. The 1A current and 1Ω sense resistor produce an output full-scale (FS) voltage of 10V (in the LT6376) and 1V (in all the other listed parts). Table 8 shows the error sources in parts per million (ppm) of the output full-scale voltage across the temperature range of 25°C to 85°C.

Different sources of error contribute to the maximum accuracy that can be achieved in an application. Gain error, offset voltage and common mode rejection error combine to set the initial error. Additionally, the gain error and offset voltage drift across the temperature range. The excellent gain accuracy, low offset voltage, high CMRR, low offset voltage drift and low gain error drift of the LT6376 all combine to enable extremely accurate measurements.

Over-The-Top OPERATION

When the input common mode voltage of the internal op amp (V_{CMOP}) in the LT6376 is biased near or above the V^+ supply, the op amp is operating in the Over-The-Top region. The op amp continues to operate with an input common mode voltage of up to 76V above V^- (regardless

of the positive power supply voltage V^+), but its performance is degraded. The op amp's input bias currents change from under $\pm 2nA$ to $14\mu A$. The op amp's input offset current rises to $\pm 50nA$ which adds $\pm 3.8mV$ to the input offset voltage.

In addition, when operating in the Over-The-Top region, the differential input impedance decreases from $1M\Omega$ in normal operation to approximately $3.7k\Omega$ in Over-The-Top operation. This resistance appears across the summing nodes of the internal op amp and boosts noise and offset while decreasing speed. Noise and offset will increase by between 66% and 83% depending on the resistor divider ratio setting. The bandwidth will be reduced by between 40% to 45%. For more detail on Over-The-Top operation, consult the LT6015 data sheet.

OUTPUT

The output of the LT6376 can typically swing to within 5mV of either rail with no load and is capable of sourcing and sinking approximately 25mA. The LT6376 is internally compensated to drive at least 1nF of capacitance under any output loading conditions. A 0.22μF capacitor in series with a 150Ω resistor between the output and ground will compensate the amplifier to drive capacitive loads greater than 1nF. Additionally, the LT6376 has more gain and phase margin as the resistor divider ratio is increased.

Table 8. Error Budget Analysis

| ERROR SOURCE | LT6376 (DIV = 6.3) | LT6375 (DIV = 7) | AD629B | COMPETITOR | ERROR, ppm of OUTPUT FS | | | |
|--|------------------------------------|----------------------|----------------------|----------------------|-------------------------|--------|--------|------------|
| | | | | | LT6376 | LT6375 | AD629B | COMPETITOR |
| Differential Gain (V/V) | 10 | 1 | 1 | 1 | | | | |
| Output FS Voltage (V) | 10 | 1 | 1 | 1 | | | | |
| Accuracy, $T_A = 25^\circ C$ | | | | | | | | |
| Initial Gain Error | 0.0075% FS | 0.006% FS | 0.03% FS | 0.02% FS | 75 | 60 | 300 | 200 |
| Output Offset Voltage | 3800μV | 450μV | 500μV | 1100μV | 380 | 450 | 500 | 1100 |
| Common Mode | $10 \cdot (80V/90dB)$ = 25300μV | 80V/89dB = 2839μV | 80V/86dB = 4009μV | 80V/90dB = 2530μV | 2530 | 2839 | 4009 | 2530 |
| Total Accuracy Error | | | | | 2985 | 3349 | 4809 | 3830 |
| Temperature Drift | | | | | | | | |
| Gain | 1ppm/°C ×60°C | 1ppm/°C ×60°C | 10ppm/°C ×60°C | 10ppm/°C ×60°C | 60 | 60 | 600 | 600 |
| Output Offset Voltage | 75μV/°C ×60°C | 12μV/°C ×60°C | 10μV/°C ×60°C | 15μV/°C ×60°C | 450 | 720 | 600 | 900 |
| Total Drift Error | | | | | 510 | 780 | 1200 | 1500 |
| Total Error | | | | | 3495 | 4129 | 6009 | 5330 |

APPLICATIONS INFORMATION

Example: An LT6376 in a DFN package mounted on a PC board has a thermal resistance of 43°C/W. Operating on ±25V supplies and driving a 2.5kΩ load to 12.5V with $V_{+IN} = 230V$ and $DIV = 10.3$, the total power dissipation is given by:

$$P_D = (50 \cdot 0.6mA) + 12.5^2/2.5k + 230^2/84.17k \\ + (228.75 - 230/10.3)^2/76k \\ + (230/10.3)^2/8.26k + (230/10.3 \\ - 12.5)^2/760k = 1.342W$$

Assuming a thermal resistance of 43°C/W, the die temperature will experience a 57.7°C rise above ambient. This implies that the maximum ambient temperature the LT6376 should operate under the above conditions is:

$$T_A = 150^\circ C - 57.7^\circ C = 92.3^\circ C$$

Keep in mind that the DFN package has an exposed pad which can be used to lower the θ_{JA} of the package. The more PCB metal connected to the exposed pad, the lower the thermal resistance.

The MSOP package has no exposed pad and a higher thermal resistance ($\theta_{JA} = 130^\circ C/W$). It should not be used in applications which have a high ambient temperature, require driving a heavy load, or require an extreme input voltage.

THERMAL SHUTDOWN

For safety, the LT6376 will enter shutdown mode when the die temperature rises to approximately 163°C. This thermal shutdown has approximately 9°C of hysteresis requiring the die temperature to cool 9°C before enabling the amplifier again.

USE AT OTHER PRECISION DC GAINS

The array of resistors within the LT6376 provides numerous configurable connections that provide precision gains other than the $G = 10$ differential gain options described previously. Note that only the +IN and -IN pins can operate outside of the supply window. Since most of these alternate configurations involve driving the REFx pins, as well as the +IN and -IN pins, the input signals must be less than the supply voltages. Fully differential gains are available as shown in Table 9, and may be output-shifted with a

REF offset signal. These configurations allow the LT6376 to be used as a versatile precision gain block with essentially no external components besides the supply decoupling. In most cases, only a single positive supply will be required. In Table 9, connections are identified as NC (no connect), INPUT (refers to both inputs driven, +signal to +pins, -signal to -pins), CROSS (refers to inputs cross-coupled, +signal to -pins, -signal to +pins), OUT (refers to the output fed back to -pins), or REF (refers to connecting the REF pin to +pins). The same configurations provide inverting gains by grounding any pins intended for the +signal source. The differential input resistance is also tabulated as well as the amplification factor of the internal gain section involved (noise-gain, which helps to estimate the error-budget of the configuration).

Single-ended noninverting gains are also available as shown in Table 10, including many that operate as buffers (loaded only by the op amp input bias). A rich option set exists by using the REF pin as an additional variable. In Table 10, connections are identified as NC (no connect), INPUT (driven by the input), OUT (fed back from the output), or GROUND (grounded). Table 10 also includes tabulations of the internal resistor divider (DIV), noise gain (re-amplification), and the input loading presented by the circuit.

USE AS PRECISION AC GAIN BLOCK

In AC-coupled applications operating from a single power supply, it is useful to set the output voltage near mid-supply to maximize dynamic range. The LT6376 readily supports this with no additional biasing components by connecting specific pins to the V^+ and V^- potentials and AC-coupling the signal paths. Table 11 shows the available inverting gains and also tabulates the load resistances presented at the input. In Table 11, connections are identified as NC (no connect), AC IN (AC-coupled to the input) OUT (fed back from the output), tied to V^+ , tied to V^- , or AC GND (AC-grounded). All pins that require an AC ground can share a single bypass capacitor. Likewise, all pins driven from the source signal may share a coupling capacitor as well. The output should also connect to the load circuitry using a coupling capacitor to block the mid-supply DC voltage.

APPLICATIONS INFORMATION

The LT6376 may also be used for single-supply noninverting AC gains by employing a combination of input attenuation and re-amplification. With numerous choices of attenuation and re-amplification, several hundred overall gain combinations are possible, ranging from 0.1 to 73. The combinations are more plentiful than the DC configurations because there is no constraint on matching internal source resistances to minimize offset.

The input attenuator section dedicates some pins to establishing a bias point and with the remaining pins, provides several choices of input signal division factors as shown in Table 12. The bias point varies between 20% and 49% of the supply voltage depending on the configuration. Swapping V^+ and V^- will bias the circuit closer to V^+ .

The high attenuations that only use +IN for the signal path can accept waveform peaks that significantly exceed the supply range. Table 12 also includes tabulations of the resulting AC load resistance presented to the signal source. Here again, all pins that require an AC-ground connection may share a single bypass capacitor, and all AC signal connections may share a coupling capacitor.

The single-supply AC-coupled noninverting circuit is completed by configuring the post-attenuator amplification factor. Table 13 shows the available re-amplification factors. Once again, all pins that require an AC-ground connection may share a single bypass capacitor, and the output should use a coupling capacitor to its load destination as well.

Table 9. Configurations for Precision Differential Gains

LT6376 DIFFERENTIAL AND INVERTING PRECISION DC GAINS

| GAIN | \pm IN | \pm REFA | \pm REFB | \pm REFC | REF | DIFF R_{IN} (k) | NOISE GAIN |
|------|----------|------------|------------|------------|-----|-------------------|------------|
| 2 | CROSS | NC | CROSS | INPUT | REF | 24.52 | 63 |
| 8 | NC | INPUT | NC | CROSS | REF | 21.11 | 73 |
| 10 | INPUT | NC | NC | NC | REF | 152 | 11 |
| 12 | NC | NC | CROSS | INPUT | REF | 29.23 | 53 |
| 18 | INPUT | INPUT | NC | CROSS | REF | 18.54 | 83 |
| 20 | NC | NC | INPUT | NC | REF | 76 | 21 |
| 22 | CROSS | NC | NC | INPUT | REF | 36.19 | 43 |
| 30 | INPUT | NC | INPUT | NC | REF | 50.67 | 31 |
| 32 | NC | NC | NC | INPUT | REF | 47.50 | 33 |
| 40 | NC | INPUT | NC | NC | REF | 38 | 41 |
| 42 | INPUT | NC | NC | INPUT | REF | 36.19 | 43 |
| 50 | INPUT | INPUT | NC | NC | REF | 30.40 | 51 |
| 52 | NC | NC | INPUT | INPUT | REF | 29.23 | 53 |
| 60 | NC | INPUT | INPUT | NC | REF | 25.33 | 61 |
| 62 | INPUT | NC | INPUT | INPUT | REF | 24.52 | 63 |
| 70 | INPUT | INPUT | INPUT | NC | REF | 21.71 | 71 |
| 72 | NC | INPUT | NC | INPUT | REF | 21.11 | 73 |
| 82 | INPUT | INPUT | NC | INPUT | REF | 18.54 | 83 |
| 92 | NC | INPUT | INPUT | INPUT | REF | 16.52 | 93 |
| 102 | INPUT | INPUT | INPUT | INPUT | REF | 14.90 | 103 |

APPLICATIONS INFORMATION

Table 10. Configurations for Precision Noninverting Gains

LT6376 NONINVERTING PRECISION DC GAINS

| GAIN | FEATURE | +IN | +REFA | +REFB | +REFC | REF | -IN | -REFA | -REFB | -REFC | NOISE GAIN | DIV | R _{IN} (k) |
|------|---------|--------|-------|-------|-------|--------|--------|--------|--------|--------|------------|------|---------------------|
| 1 | | GROUND | NC | NC | NC | INPUT | GROUND | NC | NC | NC | 11 | 11 | 836 |
| 10 | | INPUT | NC | NC | NC | GROUND | GROUND | NC | NC | NC | 11 | 1.10 | 836 |
| 11 | BUFFER | INPUT | NC | NC | NC | INPUT | GROUND | NC | NC | NC | 11 | 1 | Hi-Z |
| 30 | | INPUT | NC | INPUT | NC | GROUND | GROUND | NC | GROUND | NC | 31 | 1.03 | 785.33 |
| 31 | BUFFER | INPUT | NC | INPUT | NC | INPUT | GROUND | NC | GROUND | NC | 31 | 1 | Hi-Z |
| 32 | | NC | NC | NC | INPUT | GROUND | NC | NC | NC | GROUND | 33 | 1.03 | 783.75 |
| 40 | | NC | INPUT | NC | NC | GROUND | NC | GROUND | NC | NC | 41 | 1.03 | 779 |
| 41 | BUFFER | NC | INPUT | NC | NC | INPUT | NC | GROUND | NC | NC | 41 | 1 | Hi-Z |
| 42 | | INPUT | NC | NC | INPUT | GROUND | GROUND | NC | NC | GROUND | 43 | 1.02 | 778.10 |
| 50 | | INPUT | INPUT | NC | NC | GROUND | GROUND | GROUND | NC | NC | 51 | 1.02 | 775.20 |
| 51 | BUFFER | INPUT | INPUT | NC | NC | INPUT | GROUND | GROUND | NC | NC | 51 | 1 | Hi-Z |
| 52 | | NC | NC | INPUT | INPUT | GROUND | NC | NC | GROUND | GROUND | 53 | 1.02 | 774.62 |
| 60 | | NC | INPUT | INPUT | NC | GROUND | NC | GROUND | GROUND | NC | 61 | 1.02 | 772.67 |
| 61 | BUFFER | NC | INPUT | INPUT | NC | INPUT | NC | GROUND | GROUND | NC | 61 | 1 | Hi-Z |
| 62 | | INPUT | NC | INPUT | INPUT | GROUND | GROUND | NC | GROUND | GROUND | 63 | 1.02 | 772.26 |
| 70 | | INPUT | INPUT | INPUT | NC | GROUND | GROUND | GROUND | GROUND | NC | 71 | 1.01 | 770.86 |
| 72 | | NC | INPUT | NC | INPUT | GROUND | NC | GROUND | NC | GROUND | 73 | 1.01 | 770.56 |
| 82 | | INPUT | INPUT | NC | INPUT | GROUND | GROUND | GROUND | NC | GROUND | 83 | 1.01 | 769.27 |
| 83 | BUFFER | INPUT | INPUT | NC | INPUT | INPUT | GROUND | GROUND | NC | GROUND | 83 | 1 | Hi-Z |
| 92 | | NC | INPUT | INPUT | INPUT | GROUND | NC | GROUND | GROUND | GROUND | 93 | 1.01 | 768.26 |
| 93 | BUFFER | NC | INPUT | INPUT | INPUT | INPUT | NC | GROUND | GROUND | GROUND | 93 | 1 | Hi-Z |
| 102 | | INPUT | INPUT | INPUT | INPUT | GROUND | GROUND | GROUND | GROUND | GROUND | 103 | 1.01 | 767.45 |
| 103 | BUFFER | INPUT | INPUT | INPUT | INPUT | INPUT | GROUND | GROUND | GROUND | GROUND | 103 | 1 | Hi-Z |

APPLICATIONS INFORMATION

Table 11. Configurations for Single-Supply AC-Coupled Inverting Gains

LT6376 SINGLE-SUPPLY INVERTING AC GAINS

| GAIN | -IN | -REFA | -REFB | -REFC | +IN | +REFA | +REFB | +REFC | REF | AC R _{IN} (k) |
|------|-------|-------|-------|-------|----------------|--------|----------------|----------------|----------------|------------------------|
| -10 | AC IN | NC | NC | NC | V ⁻ | AC GND | V ⁻ | V ⁺ | V ⁻ | 76 |
| -20 | NC | NC | AC IN | NC | V ⁻ | AC GND | V ⁻ | V ⁺ | V ⁻ | 38 |
| -30 | AC IN | NC | AC IN | NC | V ⁻ | AC GND | V ⁻ | V ⁺ | V ⁻ | 25 |
| -32 | NC | NC | NC | AC IN | V ⁻ | AC GND | V ⁻ | V ⁺ | V ⁻ | 24 |
| -40 | NC | AC IN | NC | NC | V ⁻ | AC GND | V ⁻ | V ⁺ | V ⁻ | 19 |
| -42 | AC IN | NC | NC | AC IN | V ⁻ | AC GND | V ⁻ | V ⁺ | V ⁻ | 18 |
| -50 | AC IN | AC IN | NC | NC | V ⁻ | AC GND | V ⁻ | V ⁺ | V ⁻ | 15 |
| -52 | NC | NC | AC IN | AC IN | V ⁻ | AC GND | V ⁻ | V ⁺ | V ⁻ | 15 |
| -60 | NC | AC IN | AC IN | NC | V ⁻ | AC GND | V ⁻ | V ⁺ | V ⁻ | 13 |
| -62 | AC IN | NC | AC IN | AC IN | V ⁻ | AC GND | V ⁻ | V ⁺ | V ⁻ | 12 |
| -70 | AC IN | AC IN | AC IN | NC | V ⁻ | AC GND | V ⁻ | V ⁺ | V ⁻ | 11 |
| -72 | NC | AC IN | NC | AC IN | V ⁻ | AC GND | V ⁻ | V ⁺ | V ⁻ | 11 |
| -82 | AC IN | AC IN | NC | AC IN | V ⁻ | AC GND | V ⁻ | V ⁺ | V ⁻ | 9 |
| -92 | NC | AC IN | AC IN | AC IN | V ⁻ | AC GND | V ⁻ | V ⁺ | V ⁻ | 8 |
| -102 | AC IN | AC IN | AC IN | AC IN | V ⁻ | AC GND | V ⁻ | V ⁺ | V ⁻ | 7 |

Table 12. Configurations for Single-Supply AC-Coupled Input Attenuations

LT6376 SINGLE-SUPPLY AC ATTENUATOR CONFIGURATIONS

| DIV | DC BIAS | +IN | +REFA | +REFB | +REFC | REF | AC R _{IN} (k) |
|------|---------|----------------|----------------|----------------|----------------|----------------|------------------------|
| 1.41 | 0.33 | V ⁺ | AC IN | V ⁻ | AC IN | AC IN | 36 |
| 1.42 | 0.33 | V ⁺ | AC IN | V ⁻ | AC IN | NC | 36 |
| 1.43 | 0.35 | V ⁺ | AC IN | V ⁻ | AC IN | V ⁺ | 35 |
| 1.69 | 0.24 | V ⁺ | AC IN | AC IN | V ⁻ | AC IN | 31 |
| 1.70 | 0.24 | V ⁺ | AC IN | AC IN | V ⁻ | NC | 31 |
| 1.72 | 0.26 | V ⁺ | AC IN | AC IN | V ⁻ | V ⁺ | 30 |
| 1.73 | 0.33 | V ⁺ | AC IN | V ⁻ | NC | AC IN | 44 |
| 1.75 | 0.33 | V ⁺ | AC IN | V ⁻ | NC | NC | 44 |
| 1.78 | 0.35 | V ⁺ | AC IN | V ⁻ | NC | V ⁺ | 44 |
| 1.91 | 0.33 | V ⁺ | NC | V ⁻ | AC IN | AC IN | 48 |
| 1.94 | 0.33 | V ⁺ | NC | V ⁻ | AC IN | NC | 49 |
| 1.94 | 0.20 | V ⁺ | V ⁻ | AC IN | AC IN | AC IN | 30 |
| 1.96 | 0.20 | V ⁺ | V ⁻ | AC IN | AC IN | NC | 30 |
| 1.97 | 0.35 | V ⁺ | NC | V ⁻ | AC IN | V ⁺ | 48 |
| 1.98 | 0.22 | V ⁺ | V ⁻ | AC IN | AC IN | V ⁺ | 30 |
| 2.02 | 0.38 | AC IN | AC IN | V ⁺ | V ⁻ | AC IN | 30 |

APPLICATIONS INFORMATION

Table 12. Configurations for Single-Supply AC-Coupled Input Attenuations (continued)

LT6376 SINGLE-SUPPLY AC ATTENUATOR CONFIGURATIONS

| DIV | DC BIAS | +IN | +REFA | +REFB | +REFC | REF | AC R _{IN} (k) |
|-------|---------|----------------|----------------|----------------|----------------|----------------|------------------------|
| 2.04 | 0.38 | AC IN | AC IN | V ⁺ | V ⁻ | NC | 30 |
| 2.06 | 0.40 | AC IN | AC IN | V ⁺ | V ⁻ | V ⁺ | 30 |
| 2.27 | 0.38 | NC | AC IN | V ⁺ | V ⁻ | AC IN | 33 |
| 2.30 | 0.38 | NC | AC IN | V ⁺ | V ⁻ | NC | 34 |
| 2.33 | 0.40 | NC | AC IN | V ⁺ | V ⁻ | V ⁺ | 33 |
| 2.51 | 0.48 | V ⁺ | AC IN | V ⁺ | V ⁻ | AC IN | 31 |
| 2.55 | 0.48 | V ⁺ | AC IN | V ⁺ | V ⁻ | NC | 31 |
| 2.58 | 0.49 | V ⁺ | AC IN | V ⁺ | V ⁻ | V ⁺ | 31 |
| 3.12 | 0.43 | V ⁺ | V ⁻ | V ⁺ | AC IN | AC IN | 34 |
| 3.19 | 0.43 | V ⁺ | V ⁻ | V ⁺ | AC IN | NC | 35 |
| 3.22 | 0.44 | V ⁺ | V ⁻ | V ⁺ | AC IN | V ⁺ | 34 |
| 3.32 | 0.44 | AC IN | V ⁻ | AC IN | V ⁺ | AC IN | 35 |
| 3.40 | 0.44 | AC IN | V ⁻ | AC IN | V ⁺ | NC | 36 |
| 3.43 | 0.45 | AC IN | V ⁻ | AC IN | V ⁺ | V ⁺ | 36 |
| 3.38 | 0.20 | V ⁺ | V ⁻ | AC IN | NC | AC IN | 51 |
| 3.50 | 0.20 | V ⁺ | V ⁻ | AC IN | NC | NC | 53 |
| 3.55 | 0.22 | V ⁺ | V ⁻ | AC IN | NC | V ⁺ | 53 |
| 4.90 | 0.49 | V ⁻ | V ⁺ | AC IN | V ⁻ | AC IN | 45 |
| 5.10 | 0.49 | V ⁻ | V ⁺ | AC IN | V ⁻ | NC | 47 |
| 5.15 | 0.48 | V ⁻ | V ⁺ | AC IN | V ⁻ | V ⁻ | 47 |
| 5.73 | 0.38 | AC IN | NC | V ⁺ | V ⁻ | AC IN | 84 |
| 6.20 | 0.38 | AC IN | NC | V ⁺ | V ⁻ | NC | 91 |
| 6.30 | 0.40 | AC IN | NC | V ⁺ | V ⁻ | V ⁺ | 90 |
| 9.36 | 0.44 | AC IN | V ⁻ | AC GND | V ⁺ | AC IN | 77 |
| 10.20 | 0.44 | AC IN | V ⁻ | AC GND | V ⁺ | NC | 84 |
| 10.30 | 0.45 | AC IN | V ⁻ | AC GND | V ⁺ | V ⁺ | 84 |
| 31 | 0.33 | V ⁺ | NC | V ⁻ | NC | AC IN | 785 |
| 43 | 0.24 | V ⁺ | NC | NC | V ⁻ | AC IN | 778 |
| 51 | 0.20 | V ⁺ | V ⁻ | NC | NC | AC IN | 775 |
| 53 | 0.38 | NC | NC | V ⁺ | V ⁻ | AC IN | 775 |
| 61 | 0.33 | NC | V ⁻ | V ⁺ | NC | AC IN | 773 |
| 63 | 0.48 | V ⁺ | NC | V ⁺ | V ⁻ | AC IN | 772 |
| 71 | 0.43 | V ⁺ | V ⁻ | V ⁺ | NC | AC IN | 771 |
| 73 | 0.44 | NC | V ⁻ | NC | V ⁺ | AC IN | 771 |
| 83 | 0.49 | V ⁻ | V ⁺ | NC | V ⁻ | AC IN | 769 |
| 93 | 0.43 | NC | V ⁺ | V ⁻ | V ⁻ | AC IN | 768 |
| 103 | 0.49 | V ⁺ | V ⁺ | V ⁻ | V ⁻ | AC IN | 767 |

APPLICATIONS INFORMATION

Table 13. Configurations for Single-Supply AC-Coupled Re-Amplifications

LT6376 NONINVERTING AC RE-AMPLIFICATIONS

| GAIN | -IN | -REFA | -REFB | -REFC |
|-------------|------------|--------------|--------------|--------------|
| 11 | AC GND | NC | NC | NC |
| 21 | NC | NC | AC GND | NC |
| 31 | AC GND | NC | AC GND | NC |
| 33 | NC | NC | NC | AC GND |
| 41 | NC | AC GND | NC | NC |
| 43 | AC GND | NC | NC | AC GND |
| 51 | AC GND | AC GND | NC | NC |
| 53 | NC | NC | AC GND | AC GND |
| 61 | NC | AC GND | AC GND | NC |
| 63 | AC GND | NC | AC GND | AC GND |
| 71 | AC GND | AC GND | AC GND | NC |
| 73 | NC | AC GND | NC | AC GND |
| 83 | AC GND | AC GND | NC | AC GND |
| 93 | NC | AC GND | AC GND | AC GND |
| 103 | AC GND | AC GND | AC GND | AC GND |

TYPICAL APPLICATIONS

40.2dB Audio Gain Stage

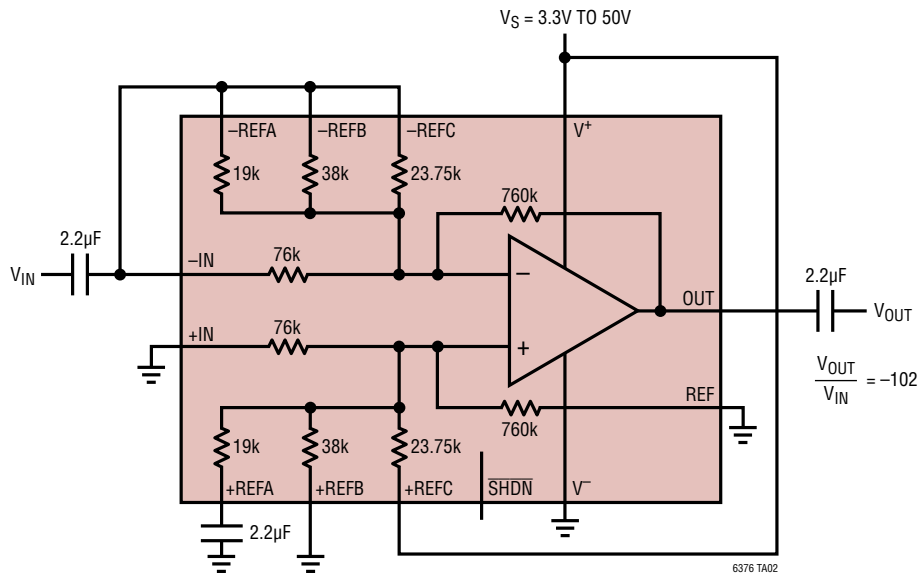

PACKAGE DESCRIPTION

Please refer to <http://www.linear.com/product/LT6376#packaging> for the most recent package drawings.

MS Package 16 (12)-Lead Plastic MSOP with 4 Pins Removed (Reference LTC DWG # 05-08-1847 Rev B)

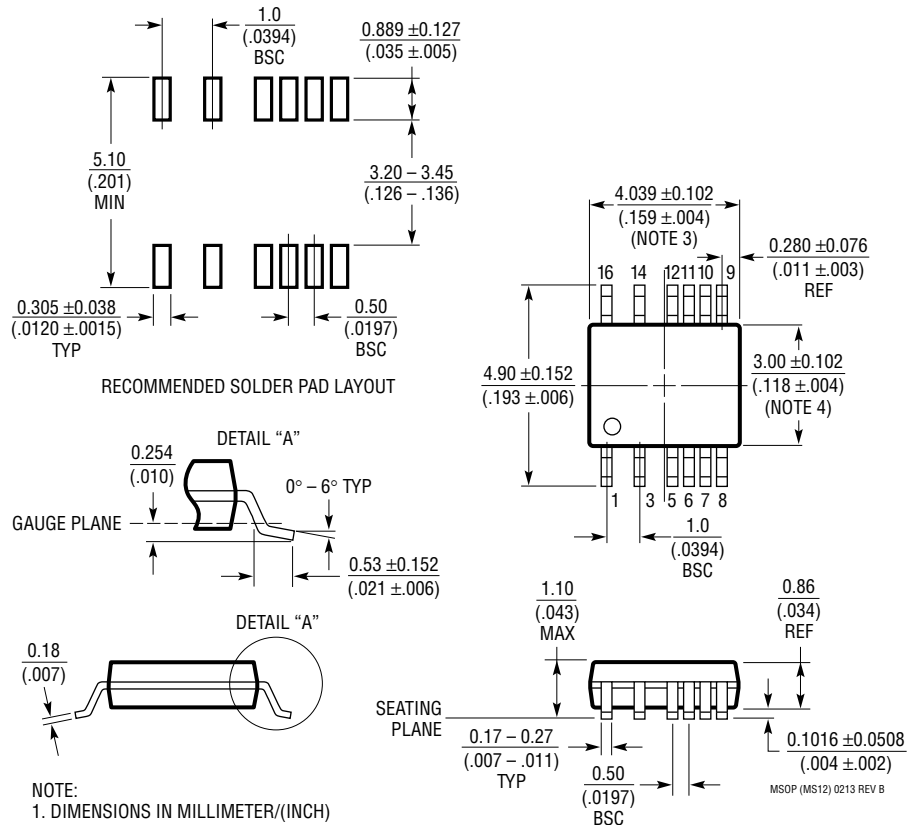

- NOTE:
1. DIMENSIONS IN MILLIMETER/(INCH)
 2. DRAWING NOT TO SCALE
 3. DIMENSION DOES NOT INCLUDE MOLD FLASH, PROTRUSIONS OR GATE BURRS.
MOLD FLASH, PROTRUSIONS OR GATE BURRS SHALL NOT EXCEED 0.152mm (.006") PER SIDE
 4. DIMENSION DOES NOT INCLUDE INTERLEAD FLASH OR PROTRUSIONS.
INTERLEAD FLASH OR PROTRUSIONS SHALL NOT EXCEED 0.152mm (.006") PER SIDE
 5. LEAD COPLANARITY (BOTTOM OF LEADS AFTER FORMING) SHALL BE 0.102mm (.004") MAX

MSOP (MS12) 0213 REV B

TYPICAL APPLICATION

Bidirectional Full Range Current Monitor

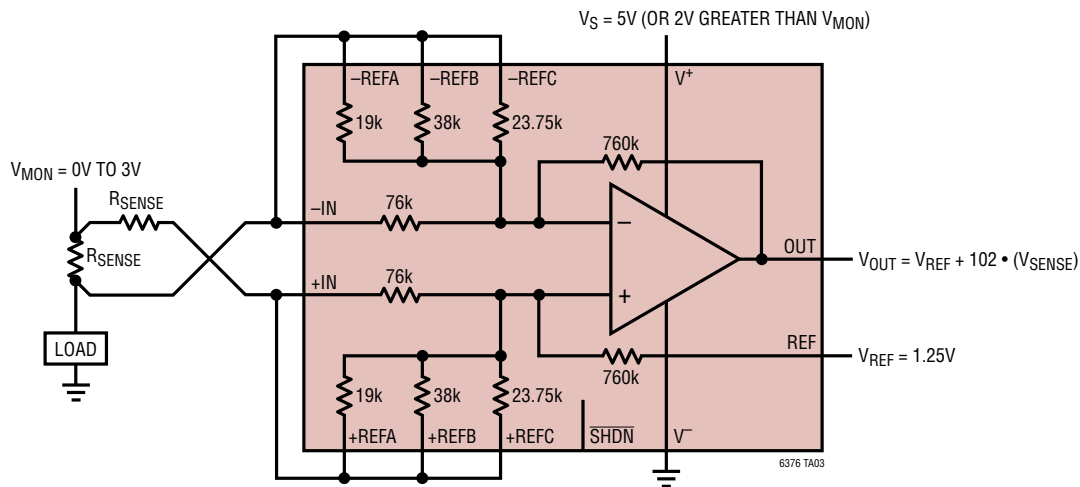

NOTE: OPERATES OVER FULL RANGE OF LOAD VOLTAGE

RELATED PARTS

| PART NUMBER | DESCRIPTION | COMMENTS |
|---|---|---|
| LT6375 | ±270V Input Range Difference Amplifier | 3.3V to 50V Operation, CMRR > 90dB, Input Voltage = ±270V, G = 1 |
| LT1990 | ±250V Input Range Difference Amplifier | 2.7V to 36V Operation, CMRR > 70dB, Input Voltage = ±250V, G = 1 AND 10 |
| LT1997-3 | Precision, Wide Voltage Range Gain Selectable Amplifier | 3.3V to 50V Operation, CMRR > 90dB, Input Voltage = ±160V, G = 1, 3 and 9 |
| LT1999-10/ LT1999-20/ LT1999-50 | High Voltage, Bidirectional Current Sense Amplifier | Input Voltage = -5V to 80V, 750μV V_{OS} , CMRR 80dB at 100kHz, Gain: 10V/V, 20V/V, 50V/V |
| LT1991 | Precision, 100μA Gain Selectable Amplifier | 2.7V to 36V Operation, 50μV Offset, CMRR > 75B, Input Voltage = ±60V |
| LT1996 | Precision, 100μA Gain Selectable Amplifier | Micropower, Pin Selectable Up to Gain = 118 |
| LTC6090 | 140V Operational Amplifier | 50pA I_B , 1.6mV V_{OS} , 9.5V to 140V V_S , 4.5mA I_S , RR Output |
| LT6108 | High Side Current Sense Amplifier with Reference and Comparator with Shutdown | 2.7V to 60V, 125μV, Resistor Set Gain, ±1.25% Threshold Error |
| LT1787/ LT1787HV | Precision, Bidirectional High Side Current Sense Amplifier | 2.7V to 60V Operation, 75μV Offset, 60μA Current Draw |
| LTC6101/ LTC6101HV | High Voltage High Side Current Sense Amplifier | 4V to 60V/5V to 100V Operation, External Resistor Set Gain, SOT23 |
| LTC6102/ LTC6102HV | Zero Drift High Side Current Sense Amplifier | 4V to 60V/5V to 100V Operation, ±10μV Offset, 1μs Step Response, MSOP8/DFN Packages |
| LTC6104 | Bidirectional, High Side Current Sense | 4V to 60V, Gain Configurable, 8-Pin MSOP Package |
| LT6015/LT6016/ LT6017 | Single, Dual, and Quad, Over-The-Top Precision Op Amp | 3.2MHz, 0.8V/μs, 50μV V_{OS} , 3V to 50V V_S , 0.335mA I_S , RRIO |
| AD629 | High Common-Mode Voltage Difference Amplifier | 5V to 36V Operation, CMRR > 86dB, Input Voltage = ±270V, G = 1 |

6376f

Looking for pricing, stock, or lifecycle information?

Click below to explore more details on WIN SOURCE:

 [View LT6376HMS#PBF on WIN SOURCE](#)

 [Analog Devices Inc. Information](#)

Optimize Your Supply Chain with WIN SOURCE Solutions

-  Global Sourcing Solution
-  Obsolete Management
-  Cost Control Management
-  Shortage Management
-  Alternative Solution
-  Excess Inventory Management