



THE DATASHEET OF DS26524G+



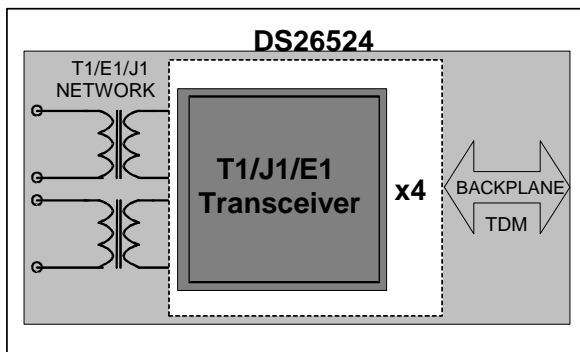
GENERAL DESCRIPTION

The DS26524 is a single-chip 4-port framer and line interface unit (LIU) combination for T1, E1, and J1 applications. Each channel is independently configurable, supporting both long-haul and short-haul lines.

APPLICATIONS

Routers
Channel Service Units (CSUs)
Data Service Units (DSUs)
Muxes
Switches
Channel Banks
T1/E1 Test Equipment

TYPICAL OPERATING CIRCUIT



ORDERING INFORMATION

PART	TEMP RANGE	PIN-PACKAGE
DS26524G	0°C to +70°C	256 TE-CSBGA
DS26524G+	0°C to +70°C	256 TE-CSBGA
DS26524GN	-40°C to +85°C	256 TE-CSBGA
DS26524GN+	-40°C to +85°C	256 TE-CSBGA

+ Denotes lead-free/RoHS compliant device.

FEATURES

- Four Complete T1, E1, or J1 Long-Haul/Short-Haul Transceivers (LIU plus Framer)
- Independent T1, E1, or J1 Selections for Each Transceiver
- Internal Software-Selectable Transmit- and Receive-Side Termination for 100Ω T1 Twisted Pair, 110Ω J1 Twisted Pair, 120Ω E1 Twisted Pair, and 75Ω E1 Coaxial Applications
- Crystal-Less Jitter Attenuator can be Selected for Transmit or Receive Path; Jitter Attenuator Meets ETS CTR 12/13, ITU-T G.736, G.742, G.823, and AT&T Pub 62411
- External Master Clock can be Multiple of 2.048MHz or 1.544MHz for T1/J1 or E1 Operation; This Clock is Internally Adapted for T1 or E1 Usage in the Host Mode
- Receive-Signal Level Indication from -2.5dB to -36dB in T1 Mode and -2.5dB to -44dB in E1 Mode in Approximate 2.5dB Increments
- Transmit Open- and Short-Circuit Detection
- LIU LOS in Accordance with G.775, ETS 300 233, and T1.231
- Transmit Synchronizer
- Flexible Signaling Extraction and Insertion Using Either the System Interface or Microprocessor Port
- Alarm Detection and Insertion
- T1 Framing Formats of D4, SLC-96, and ESF
- J1 Support
- E1 G.704 and CRC-4 Multiframe
- T1-to-E1 Conversion

Features Continued in Section 2.

TABLE OF CONTENTS

1. DETAILED DESCRIPTION	9
1.1 MAJOR OPERATING MODES	9
2. FEATURE HIGHLIGHTS	10
2.1 GENERAL	10
2.2 LINE INTERFACE	10
2.3 CLOCK SYNTHESIZER	10
2.4 JITTER ATTENUATOR	10
2.5 FRAMER/FORMATTER	10
2.6 SYSTEM INTERFACE	11
2.7 HDLC CONTROLLERS	12
2.8 TEST AND DIAGNOSTICS	12
2.9 CONTROL PORT	12
3. APPLICATIONS	13
4. SPECIFICATIONS COMPLIANCE	14
5. ACRONYMS AND GLOSSARY	16
6. BLOCK DIAGRAMS	17
7. PIN DESCRIPTIONS	19
7.1 PIN FUNCTIONAL DESCRIPTION	19
8. FUNCTIONAL DESCRIPTION	26
8.1 PROCESSOR INTERFACE	26
8.2 CLOCK STRUCTURE	26
8.2.1 <i>Backplane Clock Generation</i>	26
8.3 RESETS AND POWER-DOWN MODES	28
8.4 INITIALIZATION AND CONFIGURATION	29
8.4.1 <i>Example Device Initialization Sequence</i>	29
8.5 GLOBAL RESOURCES	29
8.6 PER-PORT RESOURCES	29
8.7 DEVICE INTERRUPTS	29
8.8 SYSTEM BACKPLANE INTERFACE	31
8.8.1 <i>Elastic Stores</i>	31
8.8.2 <i>IBO Multiplexer</i>	34
8.8.3 <i>H.100 (CT Bus) Compatibility</i>	40
8.8.4 <i>Receive and Transmit Channel Blocking Registers</i>	41
8.8.5 <i>Transmit Fractional Support (Gapped Clock Mode)</i>	41
8.8.6 <i>Receive Fractional Support (Gapped Clock Mode)</i>	41
8.9 FRAMERS	42
8.9.1 <i>T1 Framing</i>	42
8.9.2 <i>E1 Framing</i>	45
8.9.3 <i>T1 Transmit Synchronizer</i>	47
8.9.4 <i>Signaling</i>	48
8.9.5 <i>T1 Data Link</i>	52
8.9.6 <i>E1 Data Link</i>	54
8.9.7 <i>Maintenance and Alarms</i>	55
8.9.8 <i>E1 Automatic Alarm Generation</i>	58
8.9.9 <i>Error-Count Registers</i>	59
8.9.10 <i>DS0 Monitoring Function</i>	61
8.9.11 <i>Transmit Per-Channel Idle Code Insertion</i>	62

8.9.12	Receive Per-Channel Idle Code Insertion.....	62
8.9.13	Per-Channel Loopback	62
8.9.14	E1 G.706 Intermediate CRC-4 Updating (E1 Mode Only).....	62
8.9.15	T1 Programmable In-Band Loop Code Generator.....	63
8.9.16	T1 Programmable In-Band Loop Code Detection.....	64
8.9.17	Framer Payload Loopbacks	65
8.10	HDLC CONTROLLERS	66
8.10.1	Receive HDLC Controller.....	66
8.10.2	Transmit HDLC Controller.....	69
8.11	LINE INTERFACE UNITS (LIUs).....	71
8.11.1	LIU Operation.....	74
8.11.2	Transmitter.....	75
8.11.3	Receiver.....	78
8.11.4	Jitter Attenuator.....	81
8.11.5	LIU Loopbacks	82
8.12	BIT-ERROR-RATE TEST (BERT) FUNCTION	84
8.12.1	BERT Repetitive Pattern Set	85
8.12.2	BERT Error Counter.....	85
9.	DEVICE REGISTERS	86
9.1	REGISTER LISTINGS	86
9.1.1	Global Register List.....	88
9.1.2	Framer Register List.....	89
9.1.3	LIU and BERT Register List.....	96
9.2	REGISTER BIT MAPS.....	97
9.2.1	Global Register Bit Map.....	97
9.2.2	Framer Register Bit Map.....	98
9.2.3	LIU Register Bit Map.....	106
9.2.4	BERT Register Bit Map.....	106
9.3	GLOBAL REGISTER DEFINITIONS	107
9.4	FRAMER REGISTER DEFINITIONS	122
9.4.1	Receive Register Definitions.....	122
9.4.2	Transmit Register Definitions.....	181
9.5	LIU REGISTER DEFINITIONS.....	216
9.6	BERT REGISTER DEFINITIONS.....	225
10.	FUNCTIONAL TIMING	233
10.1	T1 RECEIVER FUNCTIONAL TIMING DIAGRAMS	233
10.2	T1 TRANSMITTER FUNCTIONAL TIMING DIAGRAMS	238
10.3	E1 RECEIVER FUNCTIONAL TIMING DIAGRAMS.....	243
10.4	E1 TRANSMITTER FUNCTIONAL TIMING DIAGRAMS	245
11.	OPERATING PARAMETERS.....	248
11.1	THERMAL CHARACTERISTICS.....	249
11.2	LINE INTERFACE CHARACTERISTICS.....	249
12.	AC TIMING CHARACTERISTICS	250
12.1	MICROPROCESSOR BUS AC CHARACTERISTICS.....	250
12.2	JTAG INTERFACE TIMING.....	259
12.3	SYSTEM CLOCK AC CHARACTERISTICS	260
13.	JTAG BOUNDARY SCAN AND TEST ACCESS PORT	261
13.1	TAP CONTROLLER STATE MACHINE	262
13.1.1	Test-Logic-Reset.....	262
13.1.2	Run-Test-Idle	262
13.1.3	Select-DR-Scan	262
13.1.4	Capture-DR.....	262

13.1.5	<i>Shift-DR</i>	262
13.1.6	<i>Exit1-DR</i>	262
13.1.7	<i>Pause-DR</i>	262
13.1.8	<i>Exit2-DR</i>	262
13.1.9	<i>Update-DR</i>	262
13.1.10	<i>Select-IR-Scan</i>	262
13.1.11	<i>Capture-IR</i>	263
13.1.12	<i>Shift-IR</i>	263
13.1.13	<i>Exit1-IR</i>	263
13.1.14	<i>Pause-IR</i>	263
13.1.15	<i>Exit2-IR</i>	263
13.1.16	<i>Update-IR</i>	263
13.2	INSTRUCTION REGISTER.....	265
13.2.1	<i>SAMPLE:PRELOAD</i>	265
13.2.2	<i>BYPASS</i>	265
13.2.3	<i>EXTEST</i>	265
13.2.4	<i>CLAMP</i>	265
13.2.5	<i>HIGHZ</i>	265
13.2.6	<i>IDCODE</i>	265
13.3	JTAG ID CODES.....	266
13.4	TEST REGISTERS.....	266
13.4.1	<i>Boundary Scan Register</i>	266
13.4.2	<i>Bypass Register</i>	266
13.4.3	<i>Identification Register</i>	266
14.	PIN CONFIGURATION	271
15.	PACKAGE INFORMATION	272
15.1	256-BALL TE-CSBGA (56-G6028-001).....	272
16.	DOCUMENT REVISION HISTORY	273

LIST OF FIGURES

Figure 6-1. Block Diagram	17
Figure 6-2. Detailed Block Diagram.....	18
Figure 8-1. Backplane Clock Generation.....	27
Figure 8-2. Device Interrupt Information Flow Diagram.....	30
Figure 8-3. IBO Multiplexer Equivalent Circuit—4.096MHz	35
Figure 8-4. IBO Multiplexer Equivalent Circuit—8.192MHz	36
Figure 8-5. IBO Multiplexer Equivalent Circuit—16.384MHz	37
Figure 8-6. RSYNC Input in H.100 (CT Bus) Mode.....	40
Figure 8-7. TSSYNCIO (Input Mode) Input in H.100 (CT Bus) Mode	41
Figure 8-8. CRC-4 Recalculate Method	62
Figure 8-9. Receive HDLC Example.....	68
Figure 8-10. HDLC Message Transmit Example.....	70
Figure 8-11. Network Connection for Software-Selected Termination—Longitudinal Protection	72
Figure 8-12. T1/J1 Transmit Pulse Templates	76
Figure 8-13. E1 Transmit Pulse Templates	77
Figure 8-14. Typical Monitor Application	79
Figure 8-15. Jitter Attenuation	81
Figure 8-16. Analog Loopback.....	82
Figure 8-17. Local Loopback	82
Figure 8-18. Remote Loopback	83
Figure 8-19. Dual Loopback	83
Figure 9-1. Register Memory Map for the DS26524.....	87
Figure 10-1. T1 Receive-Side D4 Timing	233
Figure 10-2. T1 Receive-Side ESF Timing.....	233
Figure 10-3. T1 Receive-Side Boundary Timing (Elastic Store Disabled).....	234
Figure 10-4. T1 Receive-Side 1.544MHz Boundary Timing (Elastic Store Enabled).....	234
Figure 10-5. T1 Receive-Side 2.048MHz Boundary Timing (Elastic Store Enabled).....	235
Figure 10-6. T1 Receive-Side Interleave Bus Operation—BYTE Mode.....	236
Figure 10-7. T1 Receive-Side Interleave Bus Operation—FRAME Mode	237
Figure 10-8. T1 Transmit-Side D4 Timing	238
Figure 10-9. T1 Transmit-Side ESF Timing.....	238
Figure 10-10. T1 Transmit-Side Boundary Timing (Elastic Store Disabled).....	239
Figure 10-11. T1 Transmit-Side 1.544MHz Boundary Timing (Elastic Store Enabled).....	239
Figure 10-12. T1 Transmit-Side 2.048MHz Boundary Timing (Elastic Store Enabled).....	240
Figure 10-13. T1 Transmit-Side Interleave Bus Operation—BYTE Mode.....	241
Figure 10-14. T1 Transmit Interleave Bus Operation—FRAME Mode.....	242
Figure 10-15. E1 Receive-Side Timing.....	243
Figure 10-16. E1 Receive-Side Boundary Timing (Elastic Store Disabled)	243
Figure 10-17. E1 Receive-Side 1.544MHz Boundary Timing (Elastic Store Enabled).....	244
Figure 10-18. E1 Receive-Side 2.048MHz Boundary Timing (Elastic Store Enabled).....	244
Figure 10-19. E1 Transmit-Side Timing.....	245
Figure 10-20. E1 Transmit-Side Boundary Timing (Elastic Store Disabled)	245
Figure 10-21. E1 Transmit-Side 1.544MHz Boundary Timing (Elastic Store Enabled).....	246
Figure 10-22. E1 Transmit-Side 2.048MHz Boundary Timing (Elastic Store Enabled).....	246
Figure 10-23. E1 G.802 Timing	247
Figure 12-1. Intel Bus Read Timing (BTS = 0)	251
Figure 12-2. Intel Bus Write Timing (BTS = 0).....	251
Figure 12-3. Motorola Bus Read Timing (BTS = 1).....	252

Figure 12-4. Motorola Bus Write Timing (BTS = 1)	252
Figure 12-5. Receive Framing Timing—Backplane (T1 Mode).....	254
Figure 12-6. Receive-Side Timing, Elastic Store Enabled (T1 Mode).....	255
Figure 12-7. Receive Framing Timing—Line Side	255
Figure 12-8. Transmit Formatter Timing—Backplane	257
Figure 12-9. Transmit Formatter Timing, Elastic Store Enabled	258
Figure 12-10. BPCLK Timing.....	258
Figure 12-11. Transmit Formatter Timing—Line Side	258
Figure 12-12. JTAG Interface Timing Diagram.....	259
Figure 13-1. JTAG Functional Block Diagram	261
Figure 13-2. TAP Controller State Diagram.....	264
Figure 14-1. Pin Configuration—256-Ball TE-CSBGA	271

LIST OF TABLES

Table 4-1. T1-Related Telecommunications Specifications	14
Table 4-2. E1-Related Telecommunications Specifications	15
Table 5-1. Time Slot Numbering Schemes.....	16
Table 7-1. Detailed Pin Descriptions	19
Table 8-1. Reset Functions.....	28
Table 8-2. Registers Related to the Elastic Store.....	31
Table 8-3. Elastic Store Delay After Initialization.....	32
Table 8-4. Registers Related to the IBO Multiplexer	34
Table 8-5. RSER Output Pin Definitions.....	38
Table 8-6. RSIG Output Pin Definitions	38
Table 8-7. TSER Input Pin Definitions	39
Table 8-8. TSIG Input Pin Definitions	39
Table 8-9. RSYNC Input Pin Definitions	39
Table 8-10. D4 Framing Mode.....	42
Table 8-11. ESF Framing Mode	43
Table 8-12. SLC-96 Framing	43
Table 8-13. E1 FAS/NFAS Framing	45
Table 8-14. Registers Related to Setting Up the Framer	46
Table 8-15. Registers Related to the Transmit Synchronizer.....	47
Table 8-16. Registers Related to Signaling	48
Table 8-17. Registers Related to SLC-96.....	51
Table 8-18. Registers Related to T1 Transmit BOC.....	52
Table 8-19. Registers Related to T1 Receive BOC.....	53
Table 8-20. Registers Related to T1 Transmit FDL.....	53
Table 8-21. Registers Related to T1 Receive FDL.....	54
Table 8-22. Registers Related to E1 Data Link	54
Table 8-23. Registers Related to Maintenance and Alarms	56
Table 8-24. T1 Alarm Criteria	58
Table 8-25. T1 Line Code Violation Counting Options	59
Table 8-26. E1 Line Code Violation Counting Options.....	60
Table 8-27. T1 Path Code Violation Counting Arrangements	60
Table 8-28. T1 Frames Out of Sync Counting Arrangements	60
Table 8-29. Registers Related to DS0 Monitoring	61
Table 8-30. Registers Related to T1 In-Band Loop Code Generator	63
Table 8-31. Registers Related to T1 In-Band Loop Code Detection	64
Table 8-32. Registers Related to Framer Payload Loopbacks.....	65
Table 8-33. Registers Related to the HDLC	66
Table 8-34. Recommended Supply Decoupling	73
Table 8-35. Registers Related to Control of DS26524 LIU	74
Table 8-36. Telecommunications Specification Compliance for DS26524 Transmitters	75
Table 8-37. Transformer Specifications.....	75
Table 8-38. ANSI T1.231, ITU-T G.775, and ETS 300 233 Loss Criteria Specifications	79
Table 8-39. Jitter Attenuator Standards Compliance.....	81
Table 8-40. Registers Related to BERT Configure, Control, and Status.....	84
Table 9-1. Register Address Ranges (in Hex).....	86
Table 9-2. Global Register List	88
Table 9-3. Framer Register List.....	89
Table 9-4. LIU Register List.....	96

Table 9-5. BERT Register List	96
Table 9-6. Global Register Bit Map.....	97
Table 9-7. Framers Register Bit Map	98
Table 9-8. LIU Register Bit Map	106
Table 9-9. BERT Register Bit Map	106
Table 9-10. Global Register Set	107
Table 9-11. Backplane Reference Clock Select	111
Table 9-12. Master Clock Input Selection.....	112
Table 9-13. Device ID Codes in this Product Family	115
Table 9-14. LIU Register Set	216
Table 9-15. Transmit Load Impedance Selection.....	217
Table 9-16. Transmit Pulse Shape Selection	217
Table 9-17. Receive Level Indication.....	222
Table 9-18. Receive Impedance Selection.....	223
Table 9-19. Receiver Sensitivity Selection with Monitor Mode Disabled.....	224
Table 9-20. Receiver Sensitivity Selection with Monitor Mode Enabled	224
Table 9-21. BERT Register Set	225
Table 9-22. BERT Pattern Select	227
Table 9-23. BERT Error Insertion Rate	228
Table 9-24. BERT Repetitive Pattern Length Select	228
Table 11-1. Recommended DC Operating Conditions	248
Table 11-2. Capacitance.....	248
Table 11-3. Recommended DC Operating Conditions	248
Table 11-4. Thermal Characteristics.....	249
Table 11-5. Transmitter Characteristics.....	249
Table 11-6. Receiver Characteristics.....	249
Table 12-1. AC Characteristics—Microprocessor Bus Timing	250
Table 12-2. Receiver AC Characteristics	253
Table 12-3. Transmit AC Characteristics.....	256
Table 12-4. JTAG Interface Timing.....	259
Table 12-5. System Clock AC Characteristics	260
Table 13-1. Instruction Codes for IEEE 1149.1 Architecture.....	265
Table 13-2. ID Code Structure.....	266
Table 13-3. Boundary Scan Control Bits	266

1. DETAILED DESCRIPTION

The DS26524 is a 4-port monolithic device featuring independent transceivers that can be software configured for T1, E1, or J1 operation. Each transceiver is composed of a line interface unit, framer, HDLC controller, elastic store, and a TDM backplane interface. The DS26524 is controlled via an 8-bit parallel port. Internal impedance matching is provided for both transmit and receive paths, reducing external component count.

The LIU is composed of a transmit interface, receive interface, and a jitter attenuator. The transmit interface is responsible for generating the necessary waveshapes for driving the network and providing the correct source impedance depending on the type of media used. T1 waveform generation includes DSX-1 line build-outs as well as CSU line build-outs of 0dB, -7.5dB, -15dB, and -22.5dB. E1 waveform generation includes G.703 waveshapes for both 75Ω coax and 120Ω twisted cables. The receive interface provides network termination and recovers clock and data from the network. The receive sensitivity adjusts automatically to the incoming signal level and can be programmed for 0dB to -43dB or 0dB to -12dB for E1 applications and 0dB to -15dB or 0dB to -36dB for T1 applications. The jitter attenuator removes phase jitter from the transmitted or received signal. The crystal-less jitter attenuator requires only a T1 or E1 clock rate, or multiple thereof, for both E1 and T1 applications, and can be placed in either transmit or receive data paths.

On the transmit side, clock, data, and frame-sync signals are provided to the framer by the backplane interface section. The framer inserts the appropriate synchronization framing patterns, alarm information, calculates and inserts the CRC codes, and provides the B8ZS/HDB3 (zero code suppression) and AMI line coding. The receive-side framer decodes AMI, B8ZS, and HDB3 line coding, synchronizes to the data stream, reports alarm information, counts framing/coding/CRC errors, and provides clock, data, and frame-sync signals to the backplane interface section.

Both transmit and receive paths have access to an HDLC controller. The HDLC controller transmits and receives data via the framer block. The HDLC controller can be assigned to any time slot, a portion of a time slot, or to FDL (T1) or Sa bits (E1). Each controller has 64-byte FIFOs, reducing the amount of processor overhead required to manage the flow of data.

The backplane interface provides a versatile method of sending and receiving data from the host system. Elastic stores provide a method for interfacing to asynchronous systems, converting from a T1/E1 network to a 2.048MHz, 4.096MHz, 8.192MHz, 16.384MHz, or N x 64kHz system backplane. The elastic stores also manage slip conditions (asynchronous interface). The interleave bus option (IBO) is provided to allow up to eight transceivers to share a high-speed backplane. The DS26524 also contains an internal clock adapter useful for the creation of a synchronous, high-frequency backplane timing source.

The parallel port provides access for configuration and status of all the DS26524's features. Diagnostic capabilities include loopbacks, PRBS pattern generation/detection, and 16-bit loop-up and loop-down code generation and detection.

1.1 Major Operating Modes

The DS26524 has two major modes of operation: T1 mode and E1 mode. The mode of operation for the LIU is configured in the LIU Transmit Receive Control register ([LTRCR](#)). The mode of operation for the framer is configured in the Transmit Master Mode register ([TMMR](#)). J1 operation is a special case of T1 operating mode.

2. FEATURE HIGHLIGHTS

2.1 General

- Member of the TEX-series transceiver family of devices. Software compatible with the DS26521 single, DS26522 dual, and DS26528 octal transceivers
- 256-pin TE-CSBGA package (17mm x 17mm, 1.00mm pitch)
- 3.3V supply with 5V tolerant inputs and outputs
- IEEE 1149.1 JTAG boundary scan
- Development support includes evaluation kit, driver source code, and reference designs

2.2 Line Interface

- Requires a single master clock (MCLK) for both E1 and T1 operation. Master clock can be 1.544MHz, 2.048MHz, 3.088MHz, 4.096MHz, 6.276MHz, 8.192MHz, 12.552MHz, or 16.384MHz
- Fully software configurable
- Short- and long-haul applications
- Ranges include 0dB to -43dB, 0dB to -30dB, 0dB to 20dB, and 0dB to -12dB for E1; 0dB to -36dB, 0dB to 30dB, 0dB to 20dB, and 0dB to -15dB for T1
- Receiver signal level indication from -2.5dB to -36dB in T1 mode and -2.5dB to -44dB in E1 mode in 2.5dB increments
- Internal receive termination option for 75 Ω , 100 Ω , 110 Ω , and 120 Ω lines
- Monitor application gain settings of 14dB, 20dB, 26dB, and 32dB
- G.703 receive synchronization signal mode
- Flexible transmit waveform generation
- T1 DSX-1 line build-outs
- T1 CSU line build-outs of 0dB, -7.5dB, -15dB, and -22.5dB
- E1 waveforms include G.703 waveshapes for both 75 Ω coax and 120 Ω twisted cables
- Analog loss-of-signal detection
- AIS generation independent of loopbacks
- Alternating ones and zeros generation
- Receiver power-down
- Transmitter power-down
- Transmitter short-circuit limiter with current-limit-exceeded indication
- Transmit open-circuit-detected indication

2.3 Clock Synthesizer

- Output frequencies include 2.048MHz, 4.096MHz, 8.192MHz, and 16.384MHz
- Derived from user-selected recovered receive clock

2.4 Jitter Attenuator

- 32-bit or 128-bit crystal-less jitter attenuator
- Requires only a 1.544MHz or 2.048MHz master clock or multiple thereof, for both E1 and T1 operation
- Can be placed in either the receive or transmit path or disabled
- Limit trip indication

2.5 Framer/Formatter

- Fully independent transmit and receive functionality
- Full receive and transmit path transparency
- T1 framing formats D4 and ESF per T1.403, and expanded SLC-96 support (TR-TSY-008)
- E1 FAS framing and CRC-4 multiframe per G.704, G.706, and G.732 CAS multiframe
- Transmit-side synchronizer
- Transmit midpath CRC recalculate (E1)

- Detailed alarm and status reporting with optional interrupt support
- Large path and line error counters
 - T1: BPV, CV, CRC-6, and framing bit errors
 - E1: BPV, CV, CRC-4, E-bit, and frame alignment errors
 - Timed or manual update modes
- DS1 Idle Code Generation on a per-channel basis in both transmit and receive paths
 - User defined
 - Digital Milliwatt
- ANSI T1.403-1999 support
- G.965 V5.2 link detect
- Ability to monitor one DS0 channel in both the transmit and receive paths
- In-band repeating pattern generators and detectors
 - Three independent generators and detectors
 - Patterns from 1 to 8 bits or 16 bits in length
- Bit-oriented code (BOC) support
- Flexible signaling support
 - Software or hardware based
 - Interrupt generated on change of signaling data
 - Optional receive-signaling freeze on loss of frame, loss of signal, or frame slip
 - Hardware pins provided to indicate loss of frame (LOF), loss of signal (LOS), loss of transmit clock (LOTIC), or signaling freeze condition
- Automatic RAI generation to ETS 300 011 specifications
- RAI-CI and AIS-CI support
- Expanded access to Sa and Si bits
- Option to extend carrier loss criteria to a 1ms period as per ETS 300 233
- Japanese J1 support
- Ability to calculate and check CRC-6 according to the Japanese standard
- Ability to generate Yellow Alarm according to the Japanese standard
- T1-to-E1 conversion

2.6 System Interface

- Independent two-frame receive and transmit elastic stores
- Independent control and clocking
- Controlled slip capability with status
- Minimum delay mode supported
- Flexible TDM backplane supports bus rates from 1.544MHz to 16.384MHz
- Supports T1 to CEPT (E1) conversion
- Programmable output clocks for fractional T1, E1, H0, and H12 applications
- Interleaving PCM bus operation
- Hardware signaling capability
- Receive-signaling reinsertion to a backplane multiframe sync
- Availability of signaling in a separate PCM data stream
- Signaling freezing
- Ability to pass the T1 F-bit position through the elastic stores in the 2.048MHz backplane mode
- User-selectable synthesized clock output

2.7 HDLC Controllers

- One HDLC controller engine for each T1/E1 port
- Independent 64-byte Rx and Tx buffers with interrupt support
- Access FDL, Sa, or single DS0 channel
- Compatible with polled or interrupt driven environments

2.8 Test and Diagnostics

- IEEE 1149.1 support
- Per-channel programmable on-chip bit error-rate testing (BERT)
- Pseudorandom patterns including QRSS
- User-defined repetitive patterns
- Daly pattern
- Error insertion single and continuous
- Total-bit and errored-bit counts
- Payload error insertion
- Error insertion in the payload portion of the T1 frame in the transmit path
- Errors can be inserted over the entire frame or selected channels
- Insertion options include continuous and absolute number with selectable insertion rates
- F-bit corruption for line testing
- Loopbacks (remote, local, analog, and per-channel loopback)

2.9 Control Port

- 8-bit parallel control port
- Intel or Motorola nonmultiplexed support
- Flexible status registers support polled, interrupt, or hybrid program environments
- Software reset supported
- Hardware reset pin
- Software access to device ID and silicon revision

3. APPLICATIONS

The DS26524 is useful in applications such as:

- Routers
- Channel Service Units (CSUs)
- Data Service Units (DSUs)
- Muxes
- Switches
- Channel Banks
- T1/E1 Test Equipment

4. SPECIFICATIONS COMPLIANCE

The DS26524 LIU meets all the latest relevant telecommunications specifications. [Table 4-1](#) and [Table 4-2](#) provide the T1 and E1 specifications and relevant sections that are applicable to the DS26524.

Table 4-1. T1-Related Telecommunications Specifications

ANSI T1.102: Digital Hierarchy Electrical Interface
AMI Coding
B8ZS Substitution Definition
DS1 Electrical Interface. Line rate ± 32 ppm; Pulse Amplitude between 2.4V to 3.6V peak; power level between 12.6dBm to 17.9dBm. The T1 pulse mask is provided that we comply. DSX-1 for cross connects the return loss is greater than -26dB. The DSX-1 cable is restricted up to 655 feet.
This specification also provides cable characteristics of DSX-Cross Connect cable—22 AVG cables of 1000 feet.
ANSI T1.231: Digital Hierarchy—Layer 1 in Service Performance Monitoring
BPV Error Definition; Excessive Zero Definition; LOS description; AIS definition.
ANSI T1.403: Network and Customer Installation Interface—DS1 Electrical Interface
Description of the Measurement of the T1 Characteristics—100 Ω . Pulse shape and template compliance according to T1.102; power level 12.4dBm to 19.7dBm when all ones are transmitted.
LBO for the Customer Interface (CI) is specified as 0dB, -7.5dB, and -15dB. Line rate is ± 32 ppm. Pulse Amplitude is 2.4V to 3.6V.
AIS generation as unframed all ones is defined.
The total cable attenuation is defined as 22dB. The DS26524 functions with up to -36dB cable loss.
Note that the pulse template defined by T1.403 and T1.102 are different, specifically at Times 0.61, -0.27, -34, and 0.77. The DS26524 is compliant to both templates.
Pub 62411
This specification has tighter jitter tolerance and transfer characteristics than other specifications. The jitter transfer characteristics are tighter than G.736 and jitter tolerance is tighter the G.823.
(ANSI) “Digital Hierarchy—Electrical Interfaces”
(ANSI) “Digital Hierarchy—Formats Specification”
(ANSI) “Digital Hierarchy—Layer 1 In-Service Digital Transmission Performance Monitoring”
(ANSI) “Network and Customer Installation Interfaces—DS1 Electrical Interface”
(AT&T) “Requirements for Interfacing Digital Terminal Equipment to Services Employing the Extended Super Frame Format”
(AT&T) “High Capacity Digital Service Channel Interface Specification”
(TTC) “Frame Structures on Primary and Secondary Hierarchical Digital Interfaces”
(TTC) “ISDN Primary Rate User-Network Interface Layer 1 Specification”

Table 4-2. E1-Related Telecommunications Specifications

ITU-T G.703 Physical/Electrical Characteristics of G.703 Hierarchical Digital Interfaces
Defines the 2048kbps bit rate—2048 \pm 50ppm; the transmission media are 75 Ω coax or 120 Ω twisted pair; peak-to-peak space voltage is \pm 0.237V; nominal pulse width is 244ns.
Return loss 51Hz to 102Hz is 6dB, 102Hz to 3072Hz is 8dB, 2048Hz to 3072Hz is 14dB.
Nominal peak voltage is 2.37V for coax and 3V for twisted pair.
The pulse template for E1 is defined in G.703.
ITU-T G.736 Characteristics of Synchronous Digital Multiplex Equipment Operating at 2048kbps
The peak-to-peak jitter at 2048kbps must be less than 0.05UI at 20Hz to 100Hz.
Jitter transfer between 2.048 synchronization signal and 2.048 transmission signal is provided.
ITU-T G.742 Second-Order Digital Multiplex Equipment Operating at 8448kbps
The DS26524 jitter attenuator is complaint with jitter transfer curve for sinusoidal jitter input.
ITU-T G.772
This specification provides the method for using receiver for transceiver 0 as a monitor for the remaining seven transmitter/receiver combinations.
ITU-T G.775
An LOS detection criterion is defined.
ITU-T G.823 The control of jitter and wander within digital networks that are based on 2.048kbps hierarchy.
G.823 Provides the jitter amplitude tolerance at different frequencies, specifically 20Hz, 2.4kHz, 18kHz, and 100kHz.
ETS 300 233
This specification provides LOS and AIS signal criteria for E1 mode.
Pub 62411
This specification has tighter jitter tolerance and transfer characteristics than other specifications. The jitter transfer characteristics are tighter than G.736 and jitter tolerance is tighter than G.823.
(ITU-T) "Synchronous Frame Structures used at 1544, 6312, 2048, 8488, and 44736kbps Hierarchical Levels"
(ITU-T) "Frame Alignment and Cyclic Redundancy Check (CRC) Procedures Relating to Basic Frame Structures Defined in Recommendation G.704"
(ITU-T) "Characteristics of Primary PCM Multiplex Equipment Operating at 2048kbps"
(ITU-T) Characteristics of a Synchronous Digital Multiplex Equipment Operating at 2048kbps"
(ITU-T) "Loss Of Signal (LOS) and Alarm Indication Signal (AIS) Defect Detection and Clearance Criteria"
(ITU-T) "The Control of Jitter and Wander Within Digital Networks Which are Based on the 2048kbps Hierarchy"
(ITU-T) "Primary Rate User-Network Interface—Layer 1 Specification"
(ITU-T) "Error Performance Measuring Equipment Operating at the Primary Rate and Above"
(ITU-T) "In-Service Code Violation Monitors for Digital Systems"
(ETS) "Integrated Services Digital Network (ISDN); Primary Rate User-Network Interface (UNI); Part 1/Layer 1 Specification"
(ETS) "Transmission and Multiplexing; Physical/Electrical Characteristics of Hierarchical Digital Interfaces for Equipment Using the 2048kbps-Based Plesiochronous or Synchronous Digital Hierarchies"
(ETS) "Integrated Services Digital Network (ISDN); Access Digital Section for ISDN Primary Rate"
(ETS) "Integrated Services Digital Network (ISDN); Attachment Requirements for Terminal Equipment to Connect to an ISDN Using ISDN Primary Rate Access"
(ETS) "Business Telecommunications (BT); Open Network Provision (ONP) Technical Requirements; 2048kbps Digital Unstructured Leased Lines (D2048U) Attachment Requirements for Terminal Equipment Interface"
(ETS) "Business Telecommunications (BTC); 2048kbps Digital Structured Leased Lines (D2048S); Attachment Requirements for Terminal Equipment Interface"
(ITU-T) "Synchronous Frame Structures Used at 1544, 6312, 2048, 8488, and 44736kbps Hierarchical Levels"
(ITU-T) "Frame Alignment and Cyclic Redundancy Check (CRC) Procedures Relating to Basic Frame Structures Defined in Recommendation G.704"

5. ACRONYMS AND GLOSSARY

This data sheet assumes a particular nomenclature of the T1 and E1 operating environment. In each 125 μ s T1 frame, there are 24 8-bit channels plus a framing bit. It is assumed that the framing bit is sent first followed by channel 1. For T1 and E1, each channel is made up of 8 bits, which are numbered 1 to 8. Bit 1, the MSB, is transmitted first. Bit 8, the LSB, is transmitted last.

Locked refers to two clock signals that are phase- or frequency-locked or derived from a common clock (i.e., a 1.544MHz clock can be locked to a 2.048MHz clock if they share the same 8kHz component).

Table 5-1. Time Slot Numbering Schemes

TS	0	1	2	3	4	5	6	7	8	9	10	11	12	13	14	15	16	17	18	19	20	21	22	23	24	25	26	27	28	29	30	31
Channel	1	2	3	4	5	6	7	8	9	10	11	12	13	14	15	16	17	18	19	20	21	22	23	24	25	26	27	28	29	30	31	32
Phone Channel		1	2	3	4	5	6	7	8	9	10	11	12	13	14	15		16	17	18	19	20	21	22	23	24	25	26	27	28	29	30

6. BLOCK DIAGRAMS

Figure 6-1. Block Diagram

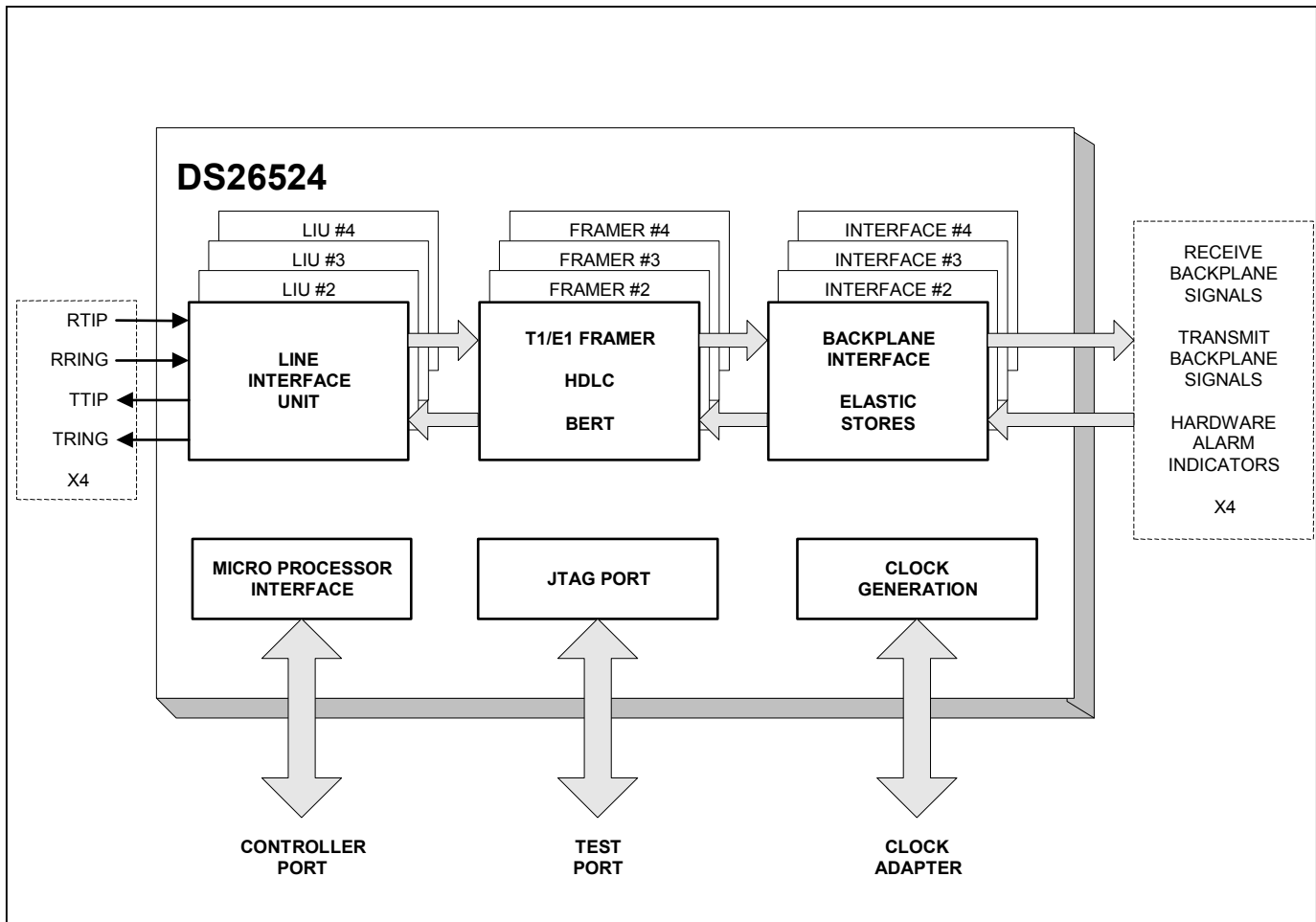
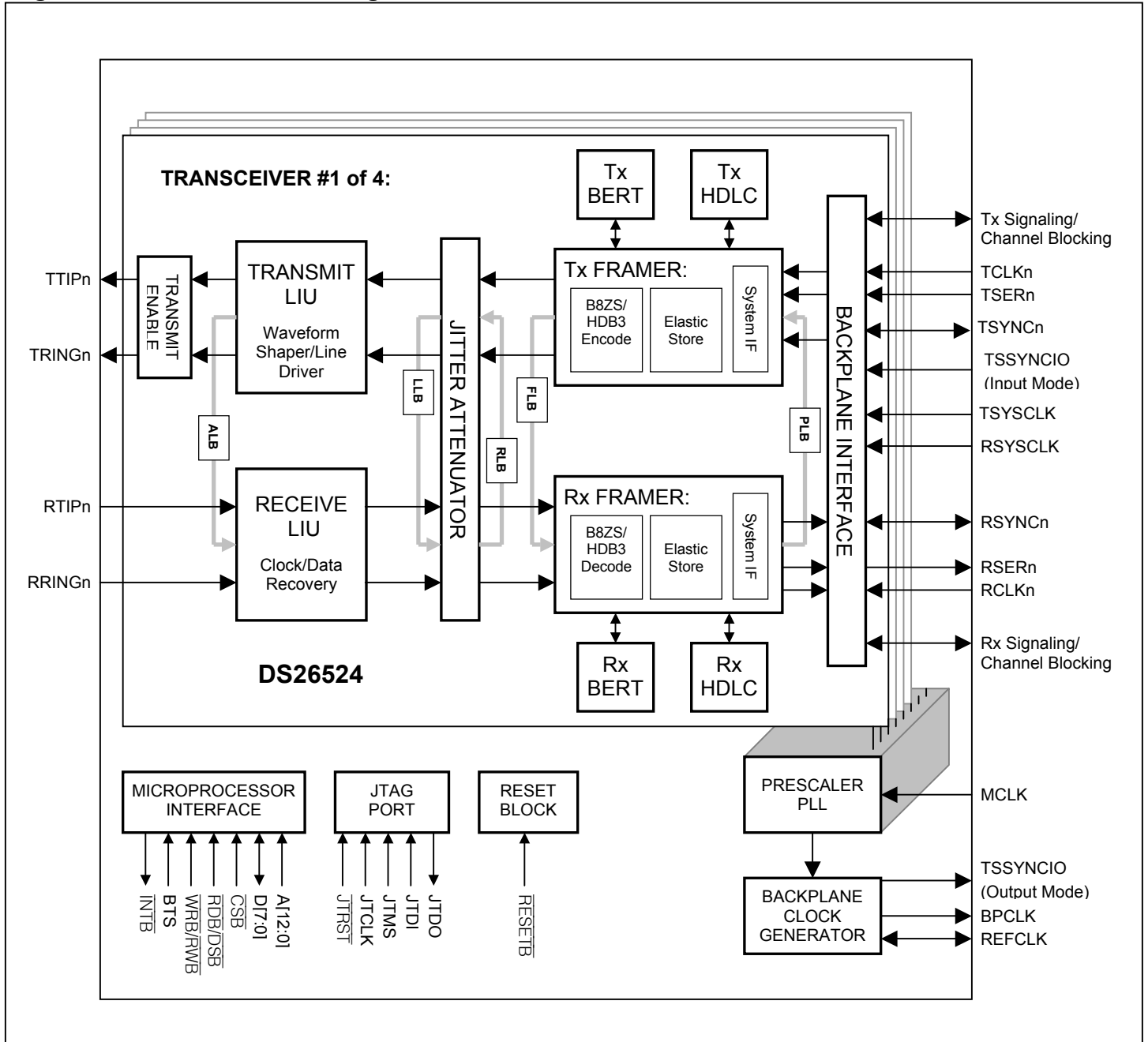


Figure 6-2. Detailed Block Diagram



7. PIN DESCRIPTIONS

7.1 Pin Functional Description

Table 7-1. Detailed Pin Descriptions

NAME	PIN	TYPE	FUNCTION
ANALOG TRANSMIT			
TTIP1	A1, A2	Analog Output, High Impedance	<p>Transmit Bipolar Tip for Transceiver 1 to 4. These pins are differential line driver tip outputs. These pins can be high impedance if:</p> <p>If TXENABLE is low, the TTIP/TRING will be high impedance. Note that if TXENABLE is low, the register settings for control of the TTIP/TRING are ignored and output is high impedance.</p> <p>The differential outputs of TTIP_n and TRING_n can provide internal matched impedance for E1 75Ω, E1 120Ω, T1 100Ω, or J1 110Ω. The user has the option of turning off internal termination.</p> <p>Note: The two pins shown for each transmit bipolar tip (e.g., pins A1 and A2 for TTIP1) should be tied together.</p>
TTIP2	H1, H2		
TTIP3	J1, J2		
TTIP4	T1, T2		
TRING1	A3, B3	Analog Output, High Impedance	<p>Transmit Bipolar Ring for Transceiver 1 to 4. These pins are differential line driver ring outputs. These pins can be high impedance if:</p> <p>If TXENABLE is low, the TTIP/TRING will be high impedance. Note that if TXENABLE is low, the register settings for control of the TTIP/TRING are ignored and output is high impedance.</p> <p>The differential outputs of TTIP_n and TRING_n can provide internal matched impedance for E1 75Ω, E1 120Ω, T1 100Ω, or J1 110Ω. The user has the option of turning off internal termination.</p> <p>Note: The two pins shown for each transmit bipolar ring (e.g., pins A3 and B3 for TRING1) should be tied together.</p>
TRING2	G3, H3		
TRING3	J3, K3		
TRING4	R3, T3		
TXENABLE	L13	I	<p>Transmit Enable. If this pin is pulled low, all transmitter outputs (TTIP and TRING) are high impedance. The register settings for tri-state control of TTIP/TRING are ignored if TXENABLE is low. If TXENABLE is high, the particular driver can be tri-stated by the register settings.</p>
ANALOG RECEIVE			
RTIP1	C1	Analog Input	<p>Receive Bipolar Tip for Transceiver 1 to 4. The differential inputs of RTIP_n and RRING_n can provide internal matched impedance for E1 75Ω, E1 120Ω, T1 100Ω, or J1 110Ω. The user has the option of turning off internal termination via the LIU Receive Impedance and Sensitivity Monitor register (LRISMR).</p>
RTIP2	F1		
RTIP3	L1		
RTIP4	P1		
RRING1	C2	Analog Input	<p>Receive Bipolar Ring for Transceiver 1 to 4. The differential inputs of RTIP_n and RRING_n can provide internal matched impedance for E1 75Ω, E1 120Ω, T1 100Ω, or J1 110Ω. The user has the option of turning off internal termination via the LIU Receive Impedance and Sensitivity Monitor register (LRISMR).</p>
RRING2	F2		
RRING3	L2		
RRING4	P2		
TRANSMIT FRAMER			
TSER1	F6	I	<p>Transmit NRZ Serial Data. These pins are sampled on the falling edge of TCLK when the transmit-side elastic store is disabled. These pins are sampled on the falling edge of TSYCLK when the transmit-side elastic store is enabled.</p> <p>In IBO mode, data for multiple framers can be used in high-speed multiplexed scheme. This is described in Section 8.8.2. The table there presents the combination of framer data for each of the streams.</p> <p>TSYCLK is used as a reference when IBO is invoked.</p>
TSER2	E7		
TSER3	R4		
TSER4	N7		

NAME	PIN	TYPE	FUNCTION
TCLK1	C5		Transmit Clock. A 1.544MHz or a 2.048MHz primary clock. Used to clock data through the transmit side of the transceiver. TSER data is sampled on the falling edge of TCLK. TCLK is used to sample TSER when the elastic store is not enabled or IBO is not used.
TCLK2	D7		
TCLK3	P5		
TCLK4	L8	I	When the elastic store is enabled, TCLKn is used as the internal transmit clock for the framer side or the elastic store, including the transmit framer and LIU. With the elastic store enabled, TCLKn can be either synchronous or asynchronous to TSYCLKn, which either prevents or allows for slips. In addition, when IBO mode is enabled, TCLKn must be synchronous to TSYCLKn, which prevents slips in the elastic store. Note: This clock must be provided for proper device operation. The only exception is when the TCR3 register is configured to source TCLK internally from RCLK.
TSYSCLK	P13	I	Transmit System Clock. 1.544MHz, 2.048MHz, 4.096MHz, 8.192MHz, or 16.384MHz clock. Only used when the transmit-side elastic store function is enabled. Should be tied low in applications that do not use the transmit-side elastic store. This is a common clock that is used for the transmitters. The clock can be 4.096MHz, 8.912MHz, or 16.384MHz when IBO mode is used.
TSYNC1	B4	I/O	Transmit Synchronization. A pulse at these pins establishes either frame or multiframe boundaries for the transmit side. These signals can also be programmed to output either a frame or multiframe pulse. If these pins are set to output pulses at frame boundaries, they can also be set to output double-wide pulses at signaling frames in T1 mode. The operation of these signals is synchronous with TCLK.
TSYNC2	F7		
TSYNC3	M6		
TSYNC4	M7		
TSSYNCIO	N13	I/O	Transmit System Synchronization In. Only used when the transmit-side elastic store is enabled. A pulse at this pin establishes either frame or multiframe boundaries for the transmit side. Note that if the elastic store is enabled, frame or multiframe boundary will be established for all four transmitters. Should be tied low in applications that do not use the transmit-side elastic store. The operation of this signal is synchronous with TSYCLK. Transmit System Synchronization Out. If configured as an output, an 8kHz pulse synchronous to the BPCLK will be generated. This pulse in combination with BPCLK can be used as an IBO master. The BPCLK can be sourced to RSYCLK, TSYCLK, and TSSYNCIO as a source to RSYNC, and TSSYNCIO of DS26524 or RSYNC and TSSYNC of other Dallas Semiconductor parts.
TSIG1	D5	I	Transmit Signaling. When enabled, this input samples signaling bits for insertion into outgoing PCM data stream. Sampled on the falling edge of TCLK when the transmit-side elastic store is disabled. Sampled on the falling edge of TSYCLK when the transmit-side elastic store is enabled. In IBO mode, the TSIG streams can run up to 16.384MHz.
TSIG2	A6		
TSIG3	T4		
TSIG4	R6		
TCHBLK/ CLK1	A5	O	Transmit Channel Block/Transmit Channel Block Clock. A dual function pin. TCHBLK is a user-programmable output that can be forced high or low during any of the channels. It is synchronous with TCLK when the transmit-side elastic store is disabled. It is synchronous with TSYCLK when the transmit-side elastic store is enabled. It is useful for blocking clocks to a serial UART or LAPD controller in applications where not all channels are used such as Fractional T1, Fractional E1, 384kbps (H0), 768kbps, or ISDN-PRI. Also useful for locating individual channels in drop-and-insert applications, for external per-channel loopback, and for per-channel conditioning. TCHCLK. TCHCLKn is a dual function pin that can output either a gapped clock or a channel clock. In gapped clock mode, TCHCLKn is a N x 64kHz fractional clock that is software programmable for 0 to 24 channels and the F-bit (T1) or 0 to 32 channels (E1). In channel clock mode, TCHCLKn is a 192kHz (T1) or 256kHz (E1) clock that pulses high during the LSB of each channel. It is useful for parallel-to-serial conversion of channel data. In either mode, TCHCLKn is synchronous with TCLKn when the receive-side elastic store is disabled or it is synchronous with TSYCLKn when the receive-side elastic store is enabled. The mode of TCHCLKn is determined by the TGCLKEN bit in the TESCR register.
TCHBLK/ CLK2	C7		
TCHBLK/ CLK3	L7		
TCHBLK/ CLK4	P7		

NAME	PIN	TYPE	FUNCTION
RECEIVE FRAMER			
RSER1	E5	O	Received Serial Data. Received NRZ serial data. Updated on rising edges of RCLK when the receive-side elastic store is disabled. Updated on the rising edges of RSYSCLK when the receive-side elastic store is enabled. When IBO mode is used, the RSER pins can output data for multiple framers. The RSER data is synchronous to RSYSCLK. This is described in Section 8.8.2 .
RSER2	D6		
RSER3	N4		
RSER4	N6		
RCLK1	F4	O	Receive Clock. A 1.544MHz (T1) or 2.048MHz (E1) clock that is used to clock data through the receive-side framer. This clock is recovered from the signal at RTIP and RRING. RSER data is output on the rising edge of RCLK. RCLK is used to output RSER when the elastic store is not enabled or IBO is not used. When the elastic store is enabled or IBO is used, the RSER is clocked by RSYSCLK.
RCLK2	G4		
RCLK3	L4		
RCLK4	M4		
RSYSCLK	L12	I	Receive System Clock. 1.544MHz, 2.048MHz, 4.096MHz, 8.192MHz, or 16.384MHz receive backplane clock. Only used when the receive-side elastic store function is enabled. Should be tied low in applications that do not use the receive-side elastic store. Multiple of 2.048MHz is expected when the IBO mode is used. Note that RSYSCLK is used for all four transceivers.
RSYNC1	A4	I/O	Receive Synchronization. If the receive-side elastic store is enabled, then this signal is used to input a frame or multiframe boundary pulse. If set to output frame boundaries, then RSYNC can be programmed to output double-wide pulses on signaling frames in T1 mode. In E1 mode, RSYNC out can be used to indicate CAS and CRC-4 multiframe. The DS26524 can accept H.100-compatible synchronization signal. The default direction of this pin at power-up is input, as determined by the RSIO control bit in the RIOCR.2 register.
RSYNC2	B6		
RSYNC3	N5		
RSYNC4	T6		
RMSYNC1/ RFSYNC1	C4	O	Receive Multiframe/Frame Synchronization. A dual function pin to indicate frame or multiframe synchronization. RFSYNC is an extracted 8kHz pulse, one RCLK wide that identifies frame boundaries. RMSYNC is an extracted pulse, one RCLK wide (elastic store disabled) or one RSYSCLK wide (elastic store enabled), that identifies multiframe boundaries. When the receive elastic store is enabled, the RMSYNC signal indicates the multiframe sync on the system (backplane) side of the elastic store. In E1 mode, this pin can indicate either the CRC-4 or CAS multiframe as determined by the RSMS2 control bit in the Receive I/O Configuration register (RIOCR.1).
RMSYNC2/ RFSYNC2	C6		
RMSYNC3/ RFSYNC3	P4		
RMSYNC4/ RFSYNC4	P6		
RSIG1	D4	O	Receive Signaling. Outputs signaling bits in a PCM format. Updated on rising edges of RCLK when the receive-side elastic store is disabled. Updated on the rising edges of RSYSCLK when the receive-side elastic store is enabled.
RSIG2	E6		
RSIG3	M5		
RSIG4	R5		
AL/ RSIGF/ FLOS1	C3	O	Analog Loss/Receive-Signaling Freeze/Framer LOS. Analog LOS reflects the LOS (loss of signal) detected by the LIU front-end and framer LOS is LOS detection by the corresponding framer; the same pins can reflect receive-signaling freeze indications. This selection can be made by settings in the Global Transceiver Clock Control register (GTCCR). If framer LOS is selected, this pin can be programmed to toggle high when the framer detects an LOS condition, or when the signaling data is frozen via either automatic or manual intervention. The indication is used to alert downstream equipment of the condition.
AL/ RSIGF/ FLOS2	F3		
AL/ RSIGF/ FLOS3	L3		
AL/ RSIGF/ FLOS4	P3		
RLF/ LTC1	D3	O	Receive Loss of Frame/Loss of Transmit Clock. This pin can be programmed to either toggle high when the synchronizer is searching for the frame and multiframe, or to toggle high if the TCLK pin has not been toggled for approximately three clock periods.
RLF/ LTC2	E3		
RLF/ LTC3	M3		
RLF/ LTC4	N3		

NAME	PIN	TYPE	FUNCTION
RCHBLK/ CLK1	E4	O	<p>Receive Channel Block/Receive Channel Block Clock. This pin can be configured to output either RCHBLK or RCHCLK. RCHBLK is a user-programmable output that can be forced high or low during any of the 24 T1 or 32 E1 channels. It is synchronous with RCLK when the receive-side elastic store is disabled. It is synchronous with RSYSCLK when the receive-side elastic store is enabled. This pin is useful for blocking clocks to a serial UART or LAPD controller in applications where not all channels are used such as fractional service, 384kbps service, 768kbps, or ISDN-PRI. Also useful for locating individual channels in drop-and-insert applications, for external per-channel loopback, and for per-channel conditioning.</p> <p>RCHCLK. RCHCLKn is a dual function pin that can output either a gapped clock or a channel clock. In gapped clock mode, RCHCLKn is a N x 64kHz fractional clock that is software programmable for 0 to 24 channels and the F-bit (T1) or 0 to 32 channels (E1). In channel clock mode, RCHCLKn is a 192kHz (T1) or 256kHz (E1) clock that pulses high during the LSB of each channel. It is useful for parallel-to-serial conversion of channel data. In either mode, RCHCLK is synchronous with RCLKn when the receive-side elastic store is disabled or it is synchronous with RSYSCLKn when the receive-side elastic store is enabled. The mode of RCHCLKn is determined by the RGCLKEN bit in the RESCR register.</p>
RCHBLK/ CLK2	B5		
RCHBLK/ CLK3	L6		
RCHBLK/ CLK4	T5		
BPCLK	E8	O	<p>Backplane Clock. Programmable clock output that can be set to 2.048MHz, 4.096MHz, 8.192MHz, or 16.384MHz. The reference for this clock can be RCLK from any of the LIU, 1.544MHz, or 2.048MHz frequency derived from MCLK or an external reference clock. This allows for the IBO clock to reference from external source or T1J1E1 recovered clock or the MCLK oscillator.</p>
MICROPROCESSOR INTERFACE			
A12	C8	I	<p>Address [12:0]. This bus selects a specific register in the DS26524 during read/write access. A12 is the MSB and A0 is the LSB.</p>
A11	A8		
A10	B8		
A9	F8		
A8	B9		
A7	A9		
A6	C9		
A5	D9		
A4	E9		
A3	F9		
A2	B10		
A1	A10		
A0	C10		
D7	T9	I	<p>Data [7:0]. This 8-bit, bidirectional data bus is used for read/write access of the DS26524 information and control registers. D7 is the MSB and D0 is the LSB.</p>
D6	N9		
D5	M9		
D4	R8		
D3	T8		
D2	P8		
D1	L9		
D0	N8		
$\overline{\text{CSB}}$	T7	I	<p>Chip-Select Bar. This active-low signal is used to qualify register read/write accesses. The $\overline{\text{RDB/DSB}}$ and $\overline{\text{WRB}}$ signals are qualified with $\overline{\text{CSB}}$.</p>
$\overline{\text{RDB/DSB}}$	M8	I	<p>Read-Data Bar/Data-Strobe Bar. This active-low signal along with $\overline{\text{CSB}}$ qualifies read access to one of the DS26524 registers. The DS26524 drives the data bus with the contents of the addressed register while $\overline{\text{RDB}}$ and $\overline{\text{CSB}}$ are low.</p>
$\overline{\text{WRB/RWB}}$	R7	I	<p>Write-Read Bar/Read-Write Bar. This active-low signal along with $\overline{\text{CSB}}$ qualifies write access to one of the DS26524 registers. Data at D[7:0] is written into the addressed register at the rising edge of $\overline{\text{WRB}}$ while $\overline{\text{CSB}}$ is low.</p>

NAME	PIN	TYPE	FUNCTION
$\overline{\text{INTB}}$	R9	U	Interrupt Bar. This active-low, open-drain output is asserted when an unmasked interrupt event is detected. $\overline{\text{INTB}}$ will be deasserted when all interrupts have been acknowledged and serviced. Extensive mask bits are provided at the global level, framer, LIU, and BERT level.
BTS	M13	I	Bus Type Select. Set high to select Motorola bus timing, low to select Intel bus timing. This pin controls the function of the RDB/DSB and WRB pins.
SYSTEM INTERFACE			
MCLK	B7	I	Master Clock. This is an independent free-running clock whose input can be a multiple of 2.048MHz \pm 50ppm or 1.544MHz \pm 50ppm. The clock selection is available by bits MPS0 and MPS1 and FREQSEL. Multiple of 2.048MHz can be internally adapted to 1.544MHz. Multiple of 1.544MHz can be adapted to 2.048MHz. Note that TCLK must be 2.048MHz for E1 and 1.544MHz for T1/J1 operation. See Table 9-12 .
$\overline{\text{RESETB}}$	J12	I	Reset Bar. Active-low reset. This input forces the complete DS26524 reset. This includes reset of the registers, framers, and LIUs.
REFCLKIO	A7	I/O	Reference Clock Input/Output <i>Input:</i> A 2.048MHz or 1.544MHz clock input. This clock can be used to generate the backplane clock. This allows for the users to synchronize the system backplane with the reference clock. The other options for the backplane clock reference are LIU-received clocks or MCLK. <i>Output:</i> This signal can also be used to output a 1.544MHz or 2.048MHz reference clock. This allows for multiple DS26524s to share the same reference for generation of the backplane clock. Hence, in a system consisting of multiple DS26524s, one can be a master and others a slave using the same reference clock.
TEST			
DIGIOEN	D8	I, Pullup	Digital Enable. When this pin and $\overline{\text{JTRST}}$ are pulled low, all digital I/O pins are placed in a high-impedance state. If this pin is high the digital I/O pins operate normally. This pin must be connected to V_{DD} for normal operation.
$\overline{\text{JTRST}}$	L5	I, Pullup	JTAG Reset. $\overline{\text{JTRST}}$ is used to asynchronously reset the test access port controller. After power-up, $\overline{\text{JTRST}}$ must be toggled from low to high. This action sets the device into the JTAG DEVICE ID mode. Pulling $\overline{\text{JTRST}}$ low restores normal device operation. $\overline{\text{JTRST}}$ is pulled high internally via a 10k Ω resistor operation. If boundary scan is not used, this pin should be held low.
JTMS	K4	I, Pullup	JTAG Mode Select. This pin is sampled on the rising edge of JTCLK and is used to place the test access port into the various defined IEEE 1149.1 states. This pin has a 10k Ω pullup resistor.
JTCLK	F5	I	JTAG Clock. This signal is used to shift data into JTDI on the rising edge and out of JTDO on the falling edge.
JTDI	H4	I, Pullup	JTAG Data In. Test instructions and data are clocked into this pin on the rising edge of JTCLK. This pin has a 10k Ω pullup resistor.
JTDO	J4	O, High impedance	JTAG Data Out. Test instructions and data are clocked out of this pin on the falling edge of JTCLK. If not used, this pin should be left unconnected.

NAME	PIN	TYPE	FUNCTION
POWER SUPPLIES			
ATVDD1	B1	—	3.3V Analog Transmit Power Supply. These V_{DD} inputs are used for the transmit LIU sections of the DS26524.
ATVDD2	G1		
ATVDD3	K1		
ATVDD4	R1		
ATVDD5	R16		
ATVDD6	K16		
ATVDD7	G16		
ATVDD8	B16		
ATVSS1	B2	—	Analog Transmit V_{SS}. These pins are used for transmit analog V_{SS} .
ATVSS2	G2		
ATVSS3	K2		
ATVSS4	R2		
ATVSS5	R15		
ATVSS6	K15		
ATVSS7	G15		
ATVSS8	B15		
ARVDD1	D1	—	3.3V Analog Receive Power Supply. These V_{DD} inputs are used for the receive LIU sections of the DS26524.
ARVDD2	E1		
ARVDD3	M1		
ARVDD4	N1		
ARVDD5	N16		
ARVDD6	M16		
ARVDD7	E16		
ARVDD8	D16		
ARVSS1	D2	—	Analog Receive V_{SS}. These pins are used for analog V_{SS} for the receivers.
ARVSS2	E2		
ARVSS3	M2		
ARVSS4	N2		
ARVSS5	N15		
ARVSS6	M15		
ARVSS7	E15		
ARVSS8	D15		
ACVDD	H7	—	Analog Clock Conversion V_{DD}. This V_{DD} input is used for the clock conversion unit of the DS26524.
ACVSS	J7	—	Analog Clock V_{SS}. This pin is used for clock converter analog V_{SS} .
DVDD	G5–G12, H8, H9	—	3.3V Power Supply for Digital Framers
DVDDIO	H5, H6, H10, H11	—	3.3V Power Supply for I/Os

NAME	PIN	TYPE	FUNCTION
DVSS	A11, A13, B11, B13, C11, C13, D12, D13, E10, F10, H12, H13, J8, J9, K5–K12, L10, L11, M10, N10, N11, P12, R10, R12, T10, T12	—	Digital Ground for the Framers
DVSSIO	J5, J6, J10, J11	—	Digital Ground for the I/Os
N.C.	A12, A14, A15, A16, B12, B14, C12, C14, C15, C16, D10, D11, D14, E11–E14, F11–F16, G13, G14, H14, H15, H16, J13–J16, K13, K14, L14, L15, L16, M11, M12, M14, N12, N14, P9, P10, P11, P14, P15, P16, R11, R13, R14, T11, T13–T16	—	No Connection. These pins must not be connected to V_{DD} or V_{SS} .

8. FUNCTIONAL DESCRIPTION

8.1 Processor Interface

Microprocessor control of the DS26524 is accomplished through the 28 hardware pins of the microprocessor port. The 8-bit parallel data bus can be configured for Intel or Motorola modes of operation with the bus type select (BTS) pin. When the BTS pin is a logic 0, bus timing is in Intel mode, as shown in [Figure 12-1](#) and [Figure 12-2](#). When the BTS pin is a logic 1, bus timing is in Motorola mode, as shown in [Figure 12-3](#) and [Figure 12-4](#). The address space is mapped through the use of 13 address lines, A[12:0]. Multiplexed mode is not supported on the processor interface.

The chip-select bar ($\overline{\text{CSB}}$) pin must be brought to a logic-low level to gain read and write access to the microprocessor port. With Intel timing selected, the read-data bar ($\overline{\text{RDB}}$) and write-read bar ($\overline{\text{WRB}}$) pins are used to indicate read and write operations and latch data through the interface. With Motorola timing selected, the read-write bar ($\overline{\text{RWB}}$) pin is used to indicate read and write operations while the data-strobe bar ($\overline{\text{DSB}}$) pin is used to latch data through the interface.

The interrupt output pin ($\overline{\text{INTB}}$) is an open-drain output that asserts a logic-low level upon a number of software maskable interrupt conditions. This pin is normally connected to the microprocessor interrupt input. The device has a bulk write mode that allows a microprocessor to write all four internal transceivers with each bus write cycle. By setting the BWE bit ([GTCR1.2](#)), each port write cycle will write to all four framers, LIUs, or BERTs at the same time. The BWE bit must be cleared before normal write operation is resumed. This function is useful for device initialization. The register map is shown in [Figure 9-1](#).

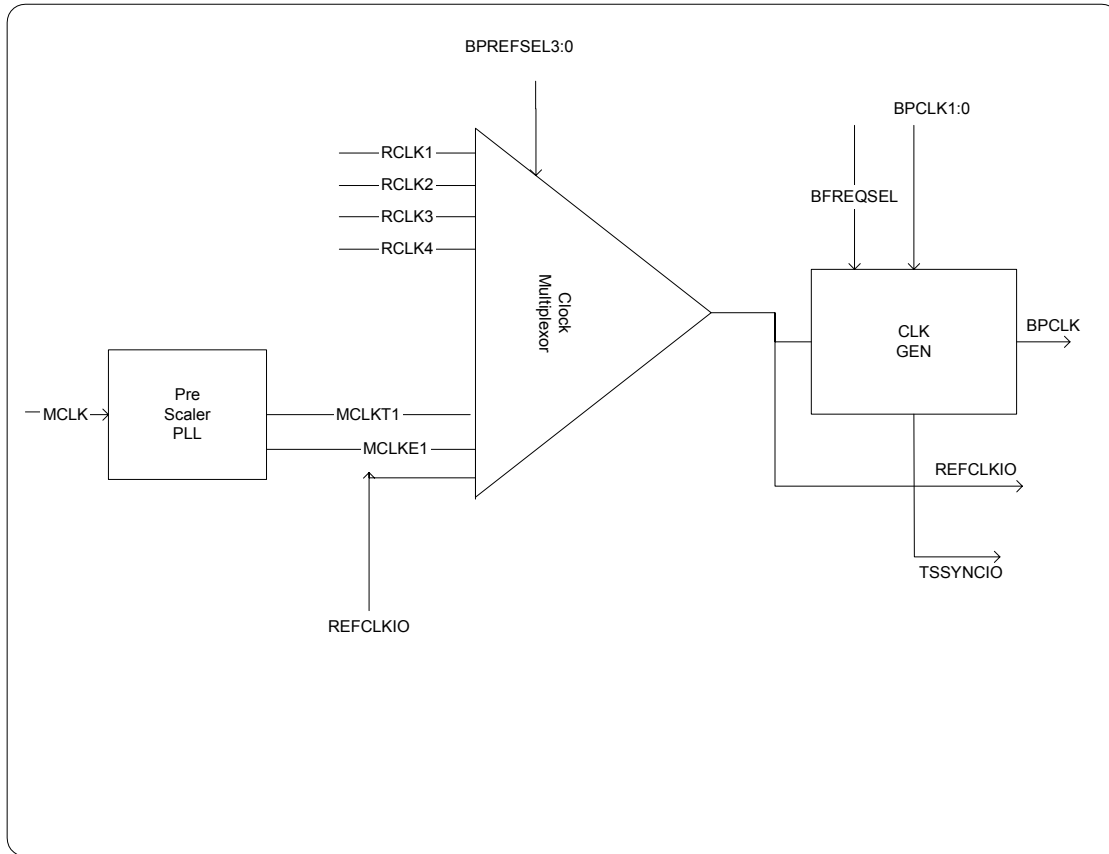
8.2 Clock Structure

The user should provide a system clock to the MCLK input of 2.048MHz, 1.544MHz, or a multiple of up to 8x the T1 and E1 frequencies. To meet many specifications, the MCLK source should have ± 50 ppm accuracy.

8.2.1 Backplane Clock Generation

The DS26524 provides facility for provision of BPCLK at 2.048MHz, 4.096MHz, 8.192MHz, 16.384MHz (see [Figure 8-1](#)). The Global Transceiver Clock Control register ([GTCCR](#)) is used to control the backplane clock generation. This register is also used to program REFCLKIO as an input or output. REFCLKIO can output MCLKT1 or MCLKE1 as shown in [Figure 8-1](#).

This backplane clock and frame pulse (TSSYNCIO) can be used by the DS26524 and other IBO-equipped devices as an IBO bus master. Hence, the DS26524 provides the 8kHz sync pulse and 4MHz, 8MHz, and 16MHz clock. This can be used by the link layer devices and frames connected to the IBO bus.

Figure 8-1. Backplane Clock Generation

The reference clock for the backplane clock generator can be as follows:

- External Master Clock. A prescaler can be used to generate T1 or E1 frequency.
- External Reference Clock REFCLKIO. This allows for multiple DS26524s to use the backplane clock from a common reference.
- Internal LIU recovered RCLKs 1 to 4.
- The clock generator can be used to generate BPCLK of 2.048MHz, 4.096MHz, 8.192MHz, or 16.384MHz for the IBO.
- If MCLK or RCLK are used as a reference, REFCLKIO can be used to provide a 2.048MHz or 1.544MHz clock for external use.

8.3 Resets and Power-Down Modes

A hardware reset is issued by forcing the $\overline{\text{RESETB}}$ pin to logic-low. The $\overline{\text{RESETB}}$ input pin resets all framers, LIUs, and BERTs. Note that not all registers are cleared to 00h on a reset condition. **The register space must be reinitialized to appropriate values after a hardware or software reset has occurred.** This includes writing reserved locations to 00h.

The DS26524 has several features included to reduce power consumption. The LIU transmitters can be powered down by setting the TPDE bit in the LIU Maintenance Control register ([LMCR](#)). Note that powering down the transmit LIU results in a high-impedance state for the corresponding TTIP and TRING pins and reduced operating current. The RPDE bit in the [LMCR](#) register can be used to power down the LIU receiver.

The TE (transmit enable) bit in the [LMCR](#) register can be used to disable the TTIP and TRING outputs and place them in a high-impedance mode, while keeping the LIU in an active state (powered up). This is useful for equipment protection-switching applications.

Table 8-1. Reset Functions

RESET FUNCTION	LOCATION	COMMENTS
Hardware Device Reset	$\overline{\text{RESETB}}$	Transition to a logic 0 level resets the DS26524.
Hardware JTAG Reset	$\overline{\text{JTRST}}$	Resets the JTAG test port.
Global Framer and BERT Reset	GFSRR .0:3	Writing to these bits resets the framer and BERT (transmit and receive).
Global LIU Reset	GLSRR .0:3	Writing to these bits resets the associated LIU.
Framer Receive Reset	RMMR .1	Writing to this bit resets the receive framer.
Framer Transmit Reset	TMMR .1	Writing to this bit resets the transmit framer.
HDLC Receive Reset	RHC .6	Writing to this bit resets the receive HDLC controller.
HDLC Transmit Reset	THC 1.5	Writing to this bit resets the transmit HDLC controller.
Elastic Store Receive Reset	RESRCR .2	Writing to this bit resets the receive elastic store.
Elastic Store Transmit Reset	TESRCR .2	Writing to this bit resets the transmit elastic store.
Bit Oriented Code Receive Reset	T1RBOCC .7	Writing to this bit resets the receive BOC controller.
Loop Code Integration Reset	T1RDNCD1 , T1RUPCD1	Writing to these registers resets the programmable in-band code integration period.
Spare Code Integration Reset	T1RSCD1	Writing to this register resets the programmable in-band code integration period.

8.4 Initialization and Configuration

8.4.1 Example Device Initialization Sequence

STEP 1: Reset the device by pulling the $\overline{\text{RESETB}}$ pin low, applying power to the device, or by using the software reset bits outlined in Section 8.3. Clear all reset bits. Allow time for the reset recovery.

STEP 2: Check the device ID in the Device Identification register ([IDR](#)).

STEP 3: Write the [GTCCR](#) register to correctly configure the system clocks. If supplying a 1.544MHz MCLK, follow this write with at least a 300ns delay to allow the clock system to properly adjust.

STEP 4: Write the entire remainder of the register space for each port with 00h, including reserved register locations.

STEP 5: Choose T1/J1 or E1 operation for the framers by configuring the T1/E1 bit in the [TMMR](#) and [RMMR](#) registers for each framer. Set the FRM_EN bit to 1 in the [TMMR](#) and [RMMR](#) registers. If using software transmit signaling in E1 mode, program the [E1TAF](#) and [E1TNAF](#) registers as required. Configure the framer Transmit Control registers ([TCR1:TCR4](#)). Configure the Framer Receive Control registers ([RCR1](#) (T1)/[RCR1](#) (E1), [T1RCR2/E1RCR2](#), [RCR3](#)). Configure other framer features as appropriate.

STEP 6: Choose T1/J1 or E1 operation for the LIUs by configuring the T1J1E1S bit in the [LTRCR](#) register. Configure the line build-out for each LIU. Configure other LIU features as appropriate. Set the TE bit to turn on the TTIP and TRING outputs.

STEP 7: Configure the elastic stores, HDLC controller, and BERT as needed.

STEP 8: Set the INIT_DONE bit in the [TMMR](#) and [RMMR](#) registers for each framer.

8.5 Global Resources

All four framers share a common microprocessor port. All ports share a common MCLK, and there is a common software-configurable BPCLK output. A set of global registers are located at 0F0h–0FFh and include global resets, global interrupt status, interrupt masking, clock configuration, and the device ID registers. See the global register definitions in [Table 9-2](#). A common JTAG controller is used.

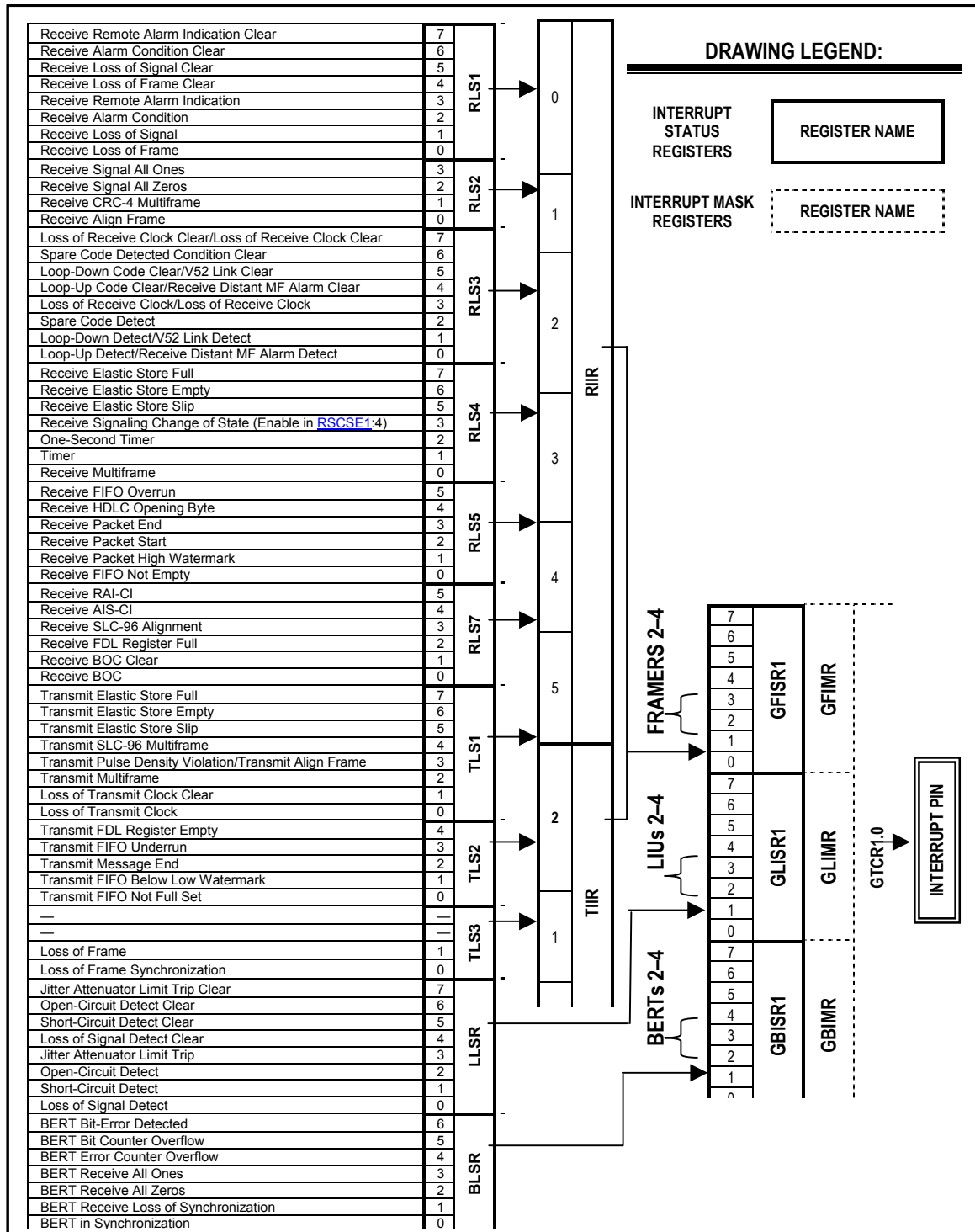
8.6 Per-Port Resources

Each port has an associated framer, LIU, BERT, jitter attenuator, and transmit/receive HDLC controller. Each of the per-port functions has its own register space.

8.7 Device Interrupts

[Figure 8-2](#) diagrams the flow of interrupt conditions from their source status bits through the multiple levels of information registers and mask bits to the interrupt pin. When an interrupt occurs, the host can read the global interrupt information registers [GFISR](#), [GLISR](#), and [GBISR](#) to identify which of the four transceivers is causing the interrupt(s). The host can then read the specific transceiver's interrupt information registers ([TIIR](#), [RIIR](#)) and the latched status registers ([LLSR](#), [BLSR](#)) to further identify the source of the interrupt(s). If [TIIR](#) or [RIIR](#) is the source, the host will then read the transmit-latched status or the receive-latched status registers for the source of the interrupt. All interrupt information register bits are real-time bits that clear once the appropriate interrupt has been serviced and cleared, as long as no additional, unmasked interrupt condition is present in the associated status register. The host must clear all latched status bits by writing a 1 to the bit location of the interrupt condition that has been serviced. Latched status bits that have been masked by the interrupt mask registers are masked from the interrupt information registers. The interrupt mask register bits prevent individual latched status conditions from generating an interrupt, but they do not prevent the latched status bits from being set. Therefore, when servicing interrupts, the user should XOR the latched status with the associated interrupt mask in order to exclude bits for which the user wished to prevent interrupt service. This architecture allows the application host to periodically poll the latched status bits for noninterrupt conditions, while using only one set of registers.

Figure 8-2. Device Interrupt Information Flow Diagram



8.8 System Backplane Interface

The DS26524 provides a versatile backplane interface that can be configured to the following:

- Transmit and receive two-frame elastic stores
- Mapping of T1 channels into a 2.048MHz backplane
- IBO mode for multiple framers to share the backplane signals
- Transmit and receive channel-blocking capability
- Fractional T1/E1/J1 support
- Hardware-based (through the backplane interface) or processor-based signaling
- Flexible backplane clock providing frequencies of 2.048MHz, 4.096MHz, 8.192MHz, 16.384MHz
- Backplane clock and frame pulse (TSSYNClOn) generator

8.8.1 Elastic Stores

The DS26524 contains dual two-frame elastic stores for each framer: one for the receive direction and one for the transmit direction. Both elastic stores are fully independent. The transmit- and receive-side elastic stores can be enabled/disabled independently of each other. Also, the transmit or receive elastic store can interface to either a 1.544MHz or 2.048/4.096/8.192/16.384MHz backplane without regard to the backplane rate for the other elastic store. Since the DS26524 has a common TSYCLK and RSYCLK for all four ports, the backplane signals in each direction must be synchronous for all ports on which the elastic stores are enabled. However, the transmit and receive signals are not required to be synchronous to each other. The TIOCR and RIOCR settings should be identical for all ports on which the elastic stores are enabled.

The elastic stores have two main purposes. First, they can be used for rate conversion. When the DS26524 is in the T1 mode, the elastic stores can rate convert the T1 data stream to a 2.048MHz backplane. In E1 mode the elastic store can rate convert the E1 data stream to a 1.544MHz backplane. Second, the elastic stores can be used to absorb the differences in frequency and phase between the T1 or E1 data stream and an asynchronous (i.e., not locked) backplane clock, which can be 1.544MHz or 2.048MHz. In this mode, the elastic stores manage the rate difference and perform controlled slips, deleting or repeating frames of data to manage the difference between the network and the backplane.

If the elastic store is enabled while in E1 mode, then either CAS or CRC-4 multiframe boundaries are indicated via the RMSYNC output as controlled by the RSMS2 control bit ([RIOCR.1](#)). If the user selects to apply a 1.544MHz clock to the RSYCLK pin, then the Receive Blank Channel Select registers ([RBCS1:RBCS4](#)) registers determine which channels of the received E1 data stream will be deleted. In this mode an F-bit location is inserted into the RSER data and set to 1. Also, in 1.544MHz applications, the RCHBLK output will not be active in Channels 25 to 32 (or in other words, RCBR4 is not active). If the two-frame elastic buffer either fills or empties, a controlled slip occurs. If the buffer empties, a full frame of data is repeated at RSER and the [RLS4.5](#) and [RLS4.6](#) bits are set to 1. If the buffer fills, a full frame of data is deleted and the [RLS4.5](#) and [RLS4.7](#) bits are set to 1.

The elastic stores can also be used to multiplex T1 or E1 data streams into higher backplane rates. This is the Interleave Bus Option (IBO), which is discussed in Section [8.8.2](#). [Table 8-2](#) shows the registers related to the elastic stores.

Table 8-2. Registers Related to the Elastic Store

REGISTER	FRAMER ADDRESSES	FUNCTION
Receive I/O Configuration Register (RIOCR)	084h	Sync and clock selection for the receiver.
Receive Elastic Store Control Register (RESCR)	085h	Receive elastic store control.
Receive Latched Status Register 4 (RLS4)	093h	Receive elastic store empty full status.
Receive Interrupt Mask Register 4 (RIM4)	0A3h	Receive interrupt mask for elastic store.
Transmit Elastic Store Control Register (TESCR)	185h	Transmit elastic control such as minimum mode.
Transmit Latched Status Register 1 (TLS1)	190h	Transmit elastic store latched status.
Transmit Interrupt Mask Register 1 (TIM1)	1A0h	Transmit elastic store interrupt mask.

Note: The addresses shown are for Framer 1. Addresses for Framers 2 to 4 can be calculated using the following: Framer n = (Framer 1 address + $(n - 1) \times 200h$), where n = 2 to 4 for Framers 2 to 4.

8.8.1.1 Elastic Stores Initialization

There are two elastic store initializations that can be used to improve performance in certain applications: elastic store reset and elastic store align. Both of these involve the manipulation of the elastic store's read and write pointers and are useful primarily in synchronous applications (RSYSCLK/TSYSCLK are locked to RCLK/TCLK, respectively). The elastic store reset is used to minimize the delay through the elastic store. The elastic store align bit is used to "center" the read/write pointers to the extent possible.

Table 8-3. Elastic Store Delay After Initialization

INITIALIZATION	REGISTER BIT	DELAY
Receive Elastic Store Reset	RESCR.2	$N \text{ bytes} < \text{Delay} < 1 \text{ Frame} + N \text{ bytes}$
Transmit Elastic Store Reset	TESCR.2	$N \text{ bytes} < \text{Delay} < 1 \text{ Frame} + N \text{ bytes}$
Receive Elastic Store Align	RESCR.3	$1/2 \text{ Frame} < \text{Delay} < 1 \text{ } 1/2 \text{ Frames}$
Transmit Elastic Store Align	TESCR.3	$1/2 \text{ Frame} < \text{Delay} < 1 \text{ } 1/2 \text{ Frames}$

$N = 9$ for $RSZS = 0$; $N = 2$ for $RSZS = 1$.

8.8.1.2 Minimum Delay Mode

Elastic store minimum-delay mode can be used when the elastic store's system clock is locked to its network clock (i.e., RCLK locked to RSYSCLK for the receive side and TCLK locked to TSYSCLK for the transmit side). [RESCR.1](#) enables the receive elastic store minimum-delay mode. When enabled, the elastic stores are forced to a maximum depth of 32 bits instead of the normal two-frame depth. This feature is useful primarily in applications that interface to a 2.048MHz bus. Certain restrictions apply when minimum-delay mode is used. In addition to the restriction mentioned above, RSYNC must be configured as an output when the receive elastic store is in minimum-delay mode and TSYNC must be configured as an output when transmit minimum-delay mode is enabled. In this mode the SYNC outputs are always in frame mode (multiframe outputs are not allowed). In a typical application, RSYSCLK and TSYSCLK are locked to RCLK and RSYNC (frame-output mode) is connected to TSSYNCIO (frame-input mode). The slip zone select bit (RSZS at [RESCR.4](#)) must be set to 1. All the slip contention logic in the framer is disabled (since slips cannot occur). On power-up, after the RSYSCLK and TSYSCLK signals have locked to their respective network clock signals, the elastic store reset bit ([RESCR.2](#)) should be toggled from a 0 to 1 to ensure proper operation

8.8.1.3 Additional Receive Elastic Store Information

If the receive-side elastic store is enabled, the user must provide either a 1.544MHz or 2.048MHz clock at the RSYSCLK pin. See Section [8.8.2](#) for higher rate system-clock applications. The user has the option of either providing a frame/multiframe sync at the RSYNC pin or having the RSYNC pin provide a pulse on frame/multiframe boundaries. If signaling reinsertion is enabled, the robbed-bit signaling data is realigned to the multiframe sync input on RSYNC. Otherwise, a multiframe sync input on RSYNC is treated as a simple frame boundary by the elastic store. The framer always indicates frame boundaries on the network side of the elastic store via the RFSYNC output, whether the elastic store is enabled or not. Multiframe boundaries are always indicated via the RMSYNC output. If the elastic store is enabled, RMSYNC outputs the multiframe boundary on the backplane side of the elastic store. When the device is receiving T1 and the backplane is enabled for 2.048MHz operation, the RMSYNC signal outputs the T1 multiframe boundaries as delayed through the elastic store. When the device is receiving E1 and the backplane is enabled for 1.544MHz operation, the RMSYNC signal outputs the E1 multiframe boundaries as delayed through the elastic store.

If the user selects to apply a 2.048MHz clock to the RSYSCLK pin, the user can use the Receive Blank Channel Select registers ([RBCS1:RBCS4](#)) to determine which channels will have the data output at RSER forced to all ones.

8.8.1.4 Receiving Mapped T1 Channels from a 2.048MHz Backplane

Setting the TSCLKM bit ([TIOCR.4](#)) enables the transmit elastic store to operate with a 2.048MHz backplane (32 time slots/frame). In this mode the user can choose which of the backplane channels on TSER will be mapped into the T1 data stream by programming the Transmit Blank Channel Select registers ([TBCS1:TBCS4](#)). A logic 1 in the associated bit location forces the transmit elastic store to ignore backplane data for that channel. Typically the user will want to program eight channels to be ignored. The default (power-up) configuration ignores channels 25 to 32, so that the first 24 backplane channels are mapped into the T1 transmit data stream.

For example, if the user desired to transmit data from the 2.048MHz backplane channels 2 to 16 and 18 to 26, the [TBCS1:TBCS4](#) registers should be programmed as follows:

```
TBCS1 = 01h  :: ignore backplane channel 1 ::
TBCS2 = 00h
TBCS3 = 01h  :: ignore backplane channel 17 ::
TBCS4 = FCh  :: ignore backplane channels 27 to 32 ::
```

8.8.1.5 Mapping T1 Channels onto a 2.048MHz Backplane

Setting the RSCLKM bit ([RIOCR.4](#)) enables the receive elastic store to operate with a 2.048MHz backplane (32 time slots/frame). In this mode the user can choose which of the backplane channels on RSER receive the T1 data by programming the Receive Blank Channel Select registers ([RBCS1:RBCS4](#)). A logic 1 in the associated bit location forces RSER high for that backplane channel. Typically the user will want to program eight channels to be blanked. The default (power-up) configuration blanks channels 25 to 32, so that the 24 T1 channels are mapped into the first 24 channels of the 2.048MHz backplane. If the user chooses to blank channel 1 (TS0) by setting [RBCS1.0](#) = 1, the F-bit will be passed into the MSB of TS0 on RSER.

For example, if:

```
RBCS1 = 01h
RBCS2 = 00h
RBCS3 = 01h
RBCS4 = FCh
```

Then on RSER:

```
Channel 1 (MSB) = F-bit
Channel 1 (bits 1 to 7) = all ones
Channels 2 to 16 = T1 channels 1 to 15
Channel 17 = all ones
Channels 18 to 26 = T1 channels 16 to 24
Channels 27 to 32 = all ones
```

Note that when two or more sequential channels are chosen to be blanked, the receive slip zone select bit should be set to 0. If the blank channels are distributed (such as 1, 5, 9, 13, 17, 21, 25, 29), the RSZS bit can be set to 1, which can provide a lower occurrence of slips in certain applications.

If the two-frame elastic buffer either fills or empties, a controlled slip occurs. If the buffer empties, a full frame of data is repeated at RSER and the [RLS4.5](#) and [RLS4.6](#) bits are set to 1. If the buffer fills, a full frame of data is deleted and the [RLS4.5](#) and [RLS4.7](#) bits are set to 1.

8.8.1.6 Receiving Mapped E1 Transmit Channels from a 1.544MHz Backplane

The user can use the TSCLKM bit in [TIOCR.4](#) to enable the transmit elastic store to operate with a 1.544MHz backplane (24 channels / frame + F-bit). In this mode the user can choose which of the E1 time slots will have all-ones data inserted by programming the Transmit Blank Channel Select registers ([TBCS1:TBCS4](#)). A logic 1 in the associated bit location causes the elastic store to force all ones at the outgoing E1 data for that channel. Typically the user will want to program eight channels to be blanked. The default (power-up) configuration blanks channels 25 to 32, so that the first 24 E1 channels are mapped from the 24 channels of the 1.544MHz backplane.

8.8.1.7 Mapping E1 Channels onto a 1.544MHz Backplane

The user can use the RSCLKM bit ([RIOCR.4](#)) to enable the receive elastic store to operate with a 1.544MHz backplane (24 channels / frame + F-bit). In this mode the user can choose which of the E1 time slots will be ignored (not transmitted onto RSER) by programming the Receive Blank Channel Select registers ([RBCS1:RBCS4](#)). A logic 1 in the associated bit location causes the elastic store to ignore the incoming E1 data for that channel. Typically the user will want to program eight channels to be ignored. The default (power-up) configuration will ignore channels 25 to 32, so that the first 24 E1 channels are mapped into the 24 channels of the 1.544MHz backplane. In this mode the F-bit location at RSER is always set to 1.

For example, if the user wants to ignore E1 time slots 0 (channel 1) and TS16 (channel 17), the [RBCS1:RBCS4](#) registers would be programmed as follows:

[RBCS1](#) = 01h
[RBCS2](#) = 00h
[RBCS3](#) = 01h
[RBCS4](#) = FCh

8.8.2 IBO Multiplexer

The Interleaved Bus Operation (IBO) multiplexer is used in conjunction with the IBO function located within each framer/formatter block (controlled by the [RIBOC](#) and [TIBOC](#) registers). When enabled, the IBO multiplexer simplifies user interface by connecting bus signals internally. The IBO multiplexer eliminates the need for ganged external wiring and tri-state output drivers on the RSER and RSIG pins. This option provides a more controlled, cleaner, and lower power mode of operation.

Note that the channel block signals TCHBLK and RCHBLK are output at the rate of the of IBO selection. Hence, a 4.096MHz IBO would have the channel blocks (if programmed active at the rate of 4.096MHz). The particular blocking channel would be active for a duration of the channel if programmed.

The DS26524 also supports the traditional mode of IBO operation by allowing complete access to individual framers, and tri-stating the RSER and RSIG pins at the appropriate times for external bus wiring. This mode of operation is enabled per framer in the associated [RIBOC](#) and [TIBOC](#) registers, while leaving the IBO multiplexer is disabled (IBOMS0 = 0 and IBOMS1 = 0).

[Figure 8-3](#), [Figure 8-4](#), and [Figure 8-5](#) show the equivalent internal circuit for each IBO mode. [Table 8-4](#) describes the pin function changes for each mode of the IBO multiplexer.

Table 8-4. Registers Related to the IBO Multiplexer

REGISTER	FRAMER ADDRESSES	FUNCTION
Global Transceiver Control Register 1 (GTCR1)	0F0h	This is a global register for all four framers. It can be used to specify ganged operation for the IBO.
Receive Interleave Bus Operation Control Register (RIBOC)	088h	This register can be used for control of how many framers and the corresponding speed for the IBO links for the receiver.
Transmit Interleave Bus Operation Control Register (TIBOC)	188h	This register can be used for control of how many framers and the corresponding speed for the IBO links for the transmitter.

Note: The addresses shown are for Framer 1. Addresses for Framers 2 to 4 can be calculated by using the following: Framer n = (Framer 1 address + (n - 1) x 200h), where n = 2 to 4 for Framers 2 to 4.

Figure 8-3. IBO Multiplexer Equivalent Circuit—4.096MHz

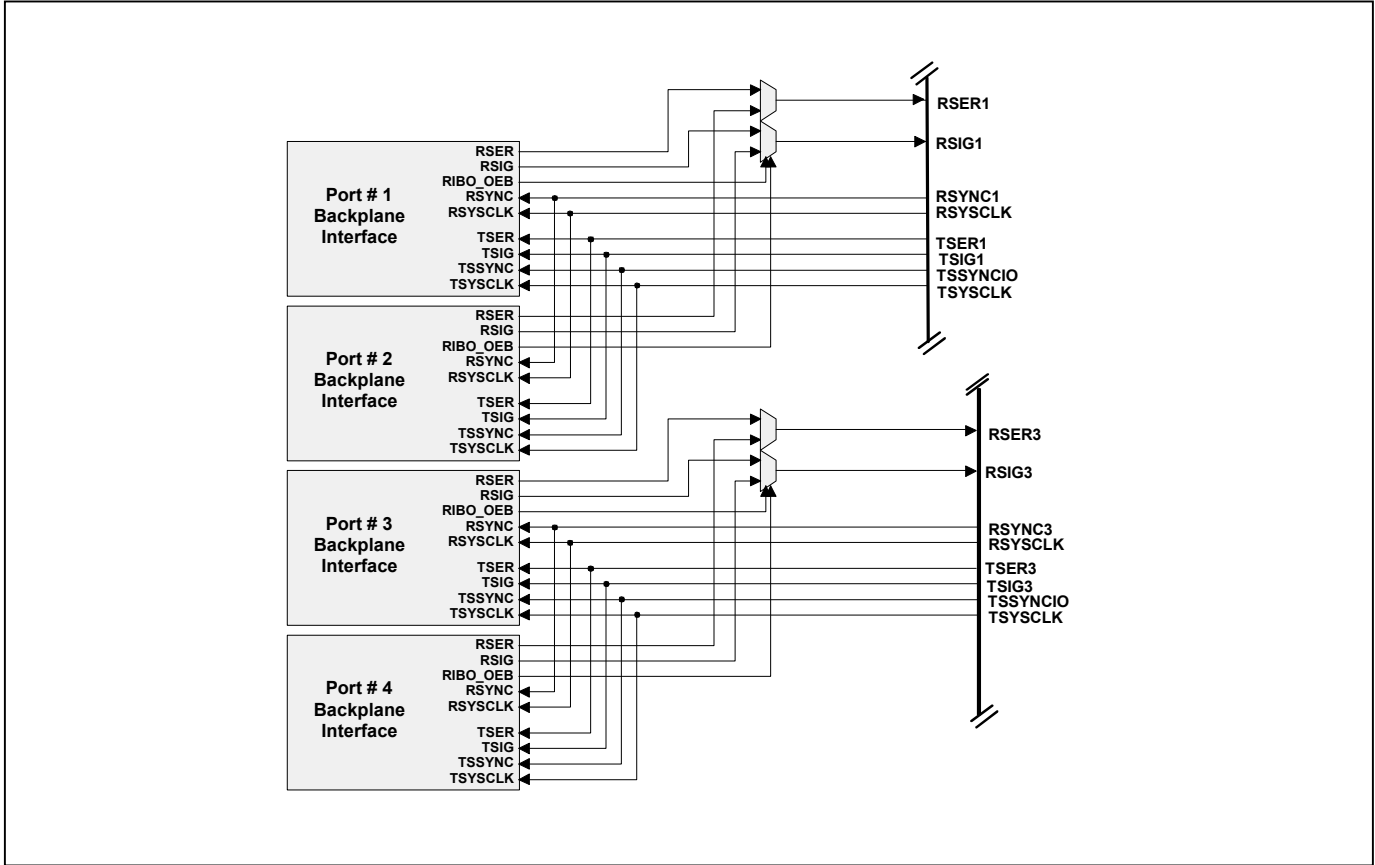


Figure 8-4. IBO Multiplexer Equivalent Circuit—8.192MHz

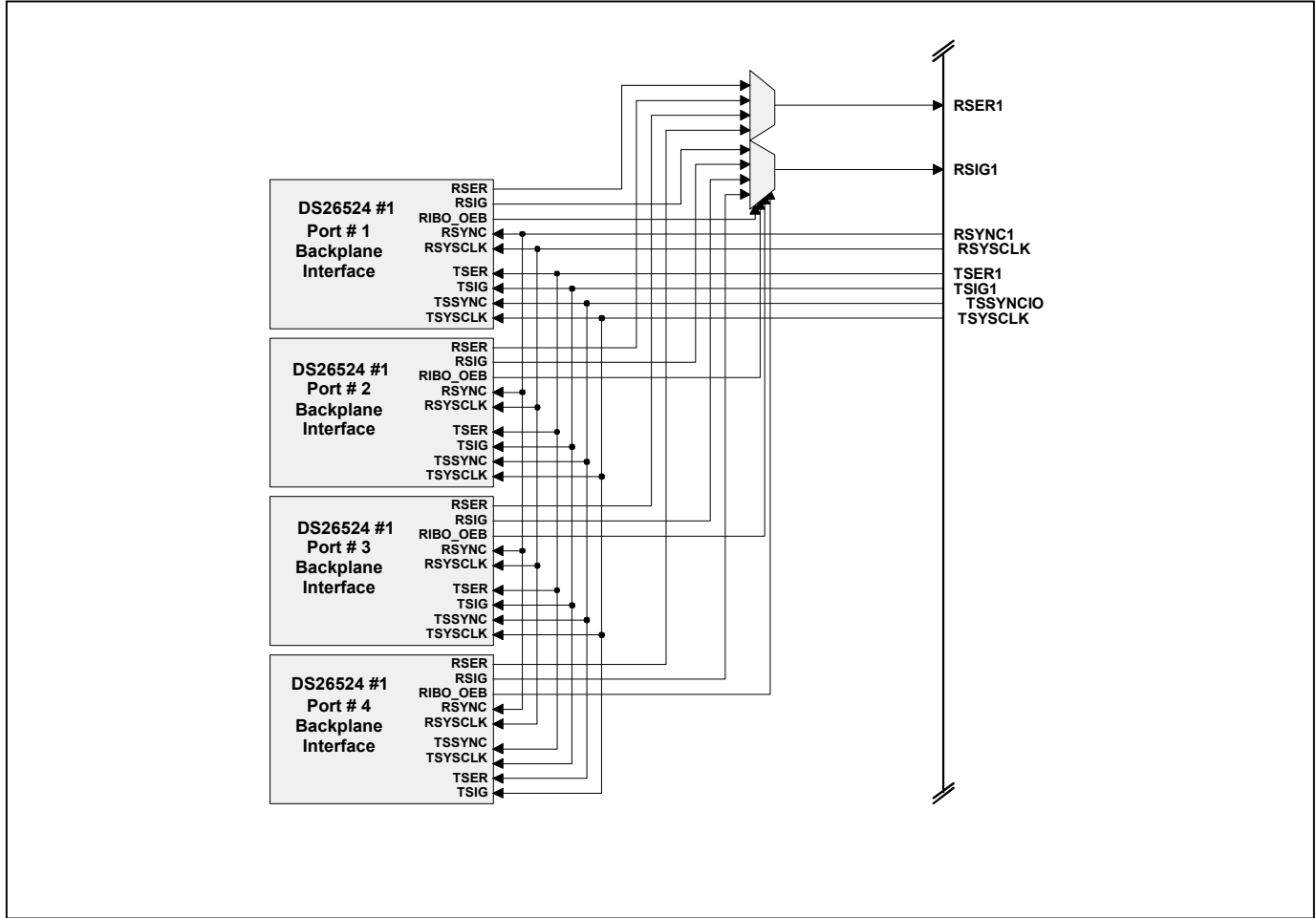


Figure 8-5. IBO Multiplexer Equivalent Circuit—16.384MHz

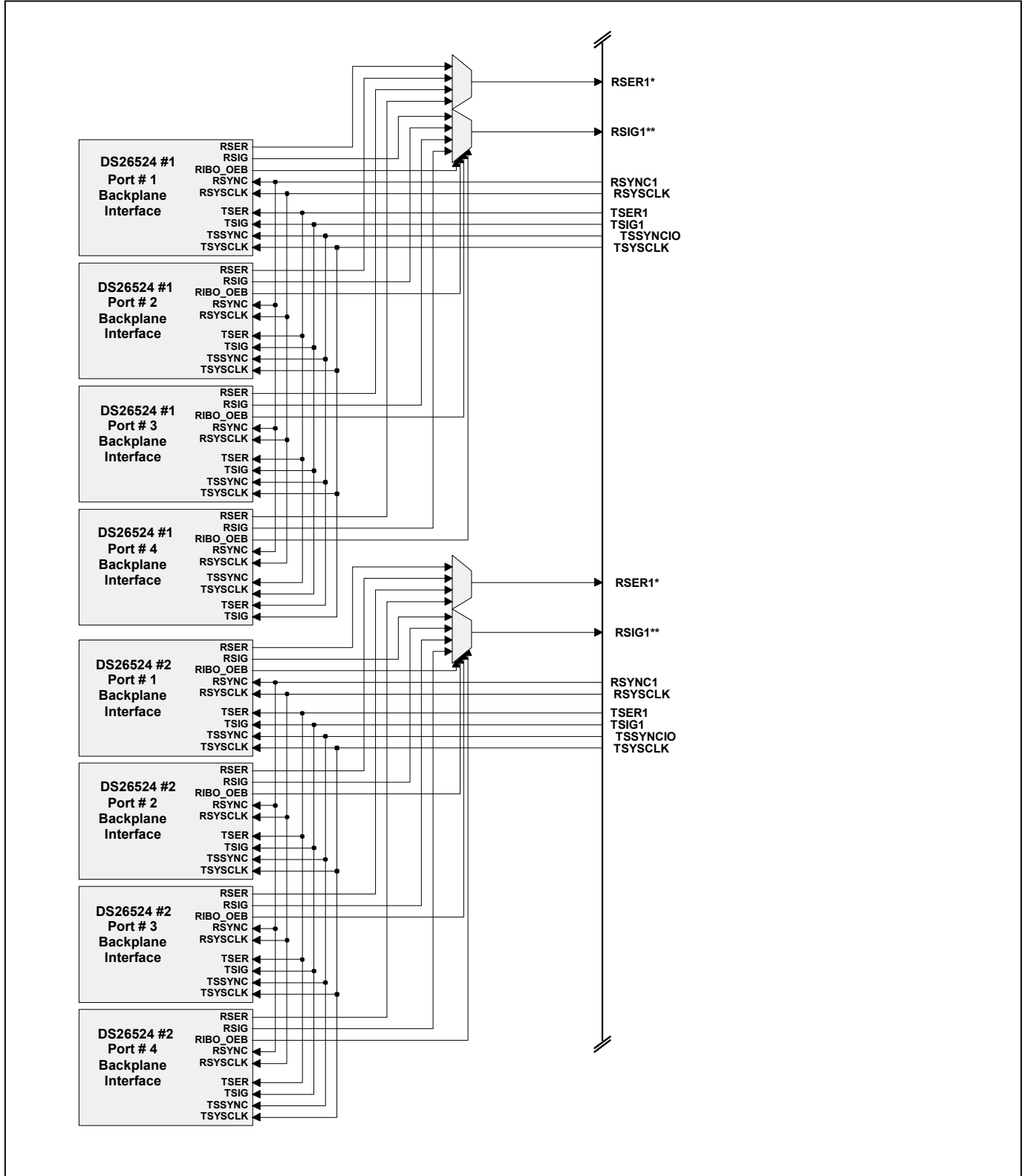


Table 8-5. RSER Output Pin Definitions

PIN	NORMAL USE	4.096MHz IBO	8.192MHz IBO	16.384MHz IBO
RSER1	Receive Serial Data for Port 1	Combined Receive Serial Data for Ports 1 and 2	Combined Receive Serial Data for Ports 1–4	Receive Serial Data for Ports 1–4
RSER2	Receive Serial Data for Port 2	Reserved	Unused	Unused
RSER3	Receive Serial Data for Port 3	Combined Receive Serial Data for Ports 3 and 4	Unused	Unused
RSER4	Receive Serial Data for Port 4	Unused	Unused	Unused

Table 8-6. RSIG Output Pin Definitions

PIN	NORMAL USE	4.096MHz IBO	8.192MHz IBO	16.384MHz IBO
RSIG1	Receive Signaling Data for Port 1	Combined Receive Signaling Data for Ports 1 and 2	Combined Receive Signaling Data for Ports 1–4	Receive Signaling Data for Ports 1–4
RSIG2	Receive Signaling Data for Port 2	Unused	Unused	Unused
RSIG3	Receive Signaling Data for Port 3	Combined Receive Signaling Data for Ports 3 and 4	Unused	Unused
RSIG4	Receive Signaling Data for Port 4	Unused	Unused	Unused

Table 8-7. TSER Input Pin Definitions

PIN	NORMAL USE	4.096MHz IBO	8.192MHz IBO	16.384MHz IBO
TSER1	Transmit Serial Data for Port 1	Combined Transmit Serial Data for Ports 1 and 2	Combined Transmit Serial Data for Ports 1–4	Transmit Serial Data for Ports 1–4
TSER2	Transmit Serial Data for Port 2	Unused	Unused	Unused
TSER3	Transmit Serial Data for Port 3	Combined Transmit Serial Data for Ports 3 and 4	Unused	Unused
TSER4	Transmit Serial Data for Port 4	Unused	Unused	Unused

Table 8-8. TSIG Input Pin Definitions

PIN	NORMAL USE	4.096MHz IBO	8.192MHz IBO	16.384MHz IBO
TSIG1	Transmit Signaling Data for Port 1	Combined Transmit Signaling Data for Ports 1 and 2	Combined Transmit Signaling Data for Ports 1–4	Transmit Signaling Data for Ports 1–4
TSIG2	Transmit Signaling Data for Port 2	Unused	Unused	Unused
TSIG3	Transmit Signaling Data for Port 3	Combined Transmit Signaling Data for Ports 3 and 4	Unused	Unused
TSIG4	Transmit Signaling Data for Port 4	Unused	Unused	Unused

Table 8-9. RSYNC Input Pin Definitions

PIN	NORMAL USE	4.096MHz IBO	8.192MHz IBO	16.384MHz IBO
RSYNC1	Receive Frame Pulse for Port 1	Receive Frame Pulse for Ports 1 and 2	Receive Frame Pulse for Ports 1–4	Receive Frame Pulse for Ports 1–4
RSYNC2	Receive Frame Pulse for Port 2	Unused	Unused	Unused
RSYNC3	Receive Frame Pulse for Port 3	Receive Frame Pulse for Ports 3 and 4	Unused	Unused
RSYNC4	Receive Frame Pulse for Port 4	Unused	Unused	Unused

8.8.3 H.100 (CT Bus) Compatibility

The registers used for controlling the H.100 backplane are [RIOCR](#) and [TIOCR](#).

The H.100 (or CT bus) is a synchronous, bit-serial, TDM transport bus operating at 8.192MHz. The H.100 standard also allows compatibility modes to operate at 2.048MHz, 4.096MHz, or 8.192MHz. The control bit H100EN ([RIOCR.5](#)), when combined with RSYNCINV and TSSYNCINV, allows the DS26524 to accept a CT bus-compatible frame-sync signal ([CT_FRAME](#)) at the RSYNC and TSSYNCIO (input mode) inputs.

The following rules apply to the H100EN control bit.

- 1) The H100EN bit controls the sampling point for the RSYNC (input mode) and TSSYNCIO (input mode) only. The RSYNC output and other sync signals are not affected.
- 2) The H100EN bit would always be used in conjunction with the receive and transmit elastic store buffers.
- 3) The H100EN bit would typically be used with 8.192MHz IBO mode, but could also be used with 4.096MHz IBO mode or 2.048MHz backplane operation.
- 4) The H100EN bit in RIOCR controls both RSYNC and TSSYNCIO (i.e., there is no separate control bit for the TSSYNCIO).
- 5) The H100EN bit does *not* invert the expected signal; RSYNCINV ([RIOCR](#)) and TSSYNCINV ([TIOCR](#)) must be set high to invert the inbound sync signals.

Figure 8-6. RSYNC Input in H.100 (CT Bus) Mode

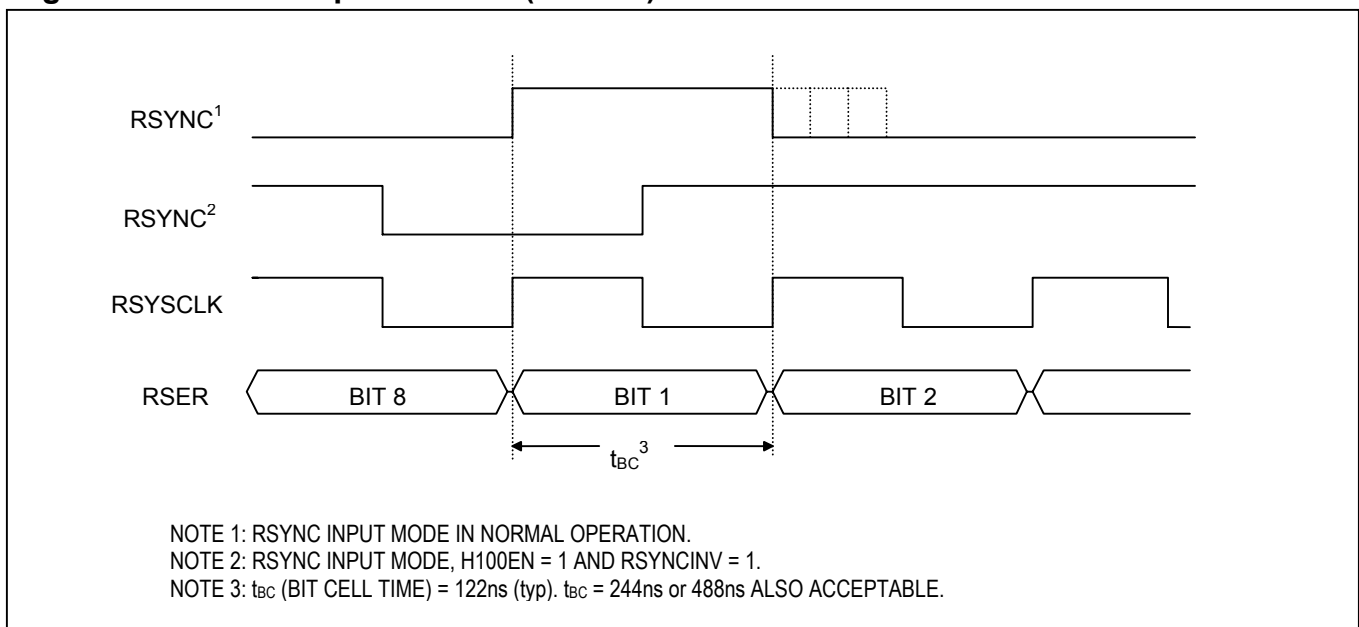
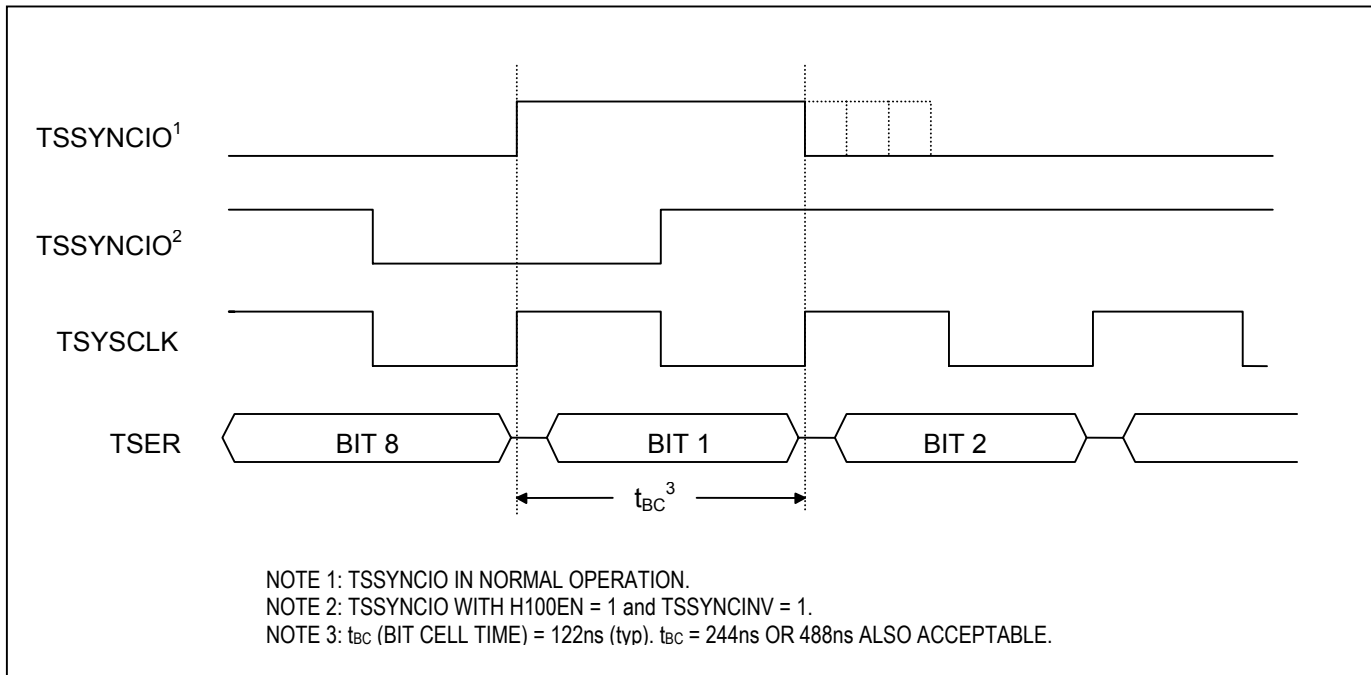


Figure 8-7. TSSYNCIO (Input Mode) Input in H.100 (CT Bus) Mode

8.8.4 Receive and Transmit Channel Blocking Registers

The Receive Channel Blocking registers ([RCBR1:RCBR4](#)) and the Transmit Channel Blocking registers ([TCBR1:TCBR4](#)) control the RCHBLK and TCHBLK pins, respectively. The RCHBLK and TCHBLK pins are user-programmable outputs that can be forced either high or low during individual channels. These outputs can be used to block clocks to a USART or LAPD controller in ISDN-PRI applications. When the appropriate bits are set to 1, the RCHBLK and TCHBLK pins are held high during the entire corresponding channel time. When used with a T1 (1.544MHz) backplane, only [TCBR1:TCBR2:TCBR3](#) are used. [TCBR4](#) is included to support an E1 (2.048MHz) backplane when the elastic store is configured for T1-to-E1 rate conversion. See Section [8.8.1](#).

8.8.5 Transmit Fractional Support (Gapped Clock Mode)

The DS26524 can be programmed to output gapped clocks for selected channels in the receive and transmit paths to simplify connections into a USART or LAPD controller in fractional T1/E1 or ISDN-PRI applications. When the gapped clock feature is enabled, a gated clock is output on the TCHCLK signal. The channel selection is controlled via the Transmit Gapped-Clock Channel Select registers ([TGCCS1:TGCCS4](#)). The transmit path is enabled for gapped clock mode with the TGCLKEN bit ([TESCR.6](#)). Both 56kbps and 64kbps channel formats are supported as determined by [TESCR.7](#). When 56kbps mode is selected, the clock corresponding to the data/control bit in the channel is omitted (only the seven most significant bits of the channel have clocks).

8.8.6 Receive Fractional Support (Gapped Clock Mode)

The DS26524 can be programmed to output gapped clocks for selected channels in the receive and transmit paths to simplify connections into a USART or LAPD controller in fractional T1/E1 or ISDN-PRI applications. When the gapped clock feature is enabled, a gated clock is output on the RCHCLK signal. The channel selection is controlled via the Receive Gapped-Clock Channel Select registers ([RGCCS1:RGCCS4](#)). The receive path is enabled for gapped clock mode with the RGCLKEN bit ([RESOCR.6](#)). Both 56kbps and 64kbps channel formats are supported as determined by [RESOCR.7](#). When 56kbps mode is selected, the clock corresponding to the data/control bit in the channel is omitted (only the seven most significant bits of the channel have clocks).

8.9 Framers

The DS26524 framer cores are software selectable for T1, J1, or E1. The receive framer locates the frame and multiframe boundaries and monitors the data stream for alarms. It is also used for extracting and inserting signaling data, T1 FDL data, and E1 Si- and Sa-bit information. The receive-side framer decodes AMI, B8ZS line coding, synchronizes to the data stream, reports alarm information, counts framing/coding and CRC errors, and provides clock/data and frame-sync signals to the backplane interface section. Diagnostic capabilities include loopbacks, and 16-bit loop-up and loop-down code detection. The device contains a set of internal registers for host access and control of the device.

On the transmit side, clock, data, and frame-sync signals are provided to the framer by the backplane interface section. The framer inserts the appropriate synchronization framing patterns, alarm information, calculates and inserts the CRC codes, and provides the B8ZS (zero code suppression) and AMI line coding.

Both the transmit and receive path have an HDLC controller. The HDLC controller transmits and receives data via the framer block. The HDLC controller can be assigned to any time slot, portion of a time slot, or to FDL (T1). The HDLC controller has separate 64-byte Tx and Rx FIFO to reduce the amount of processor overhead required to manage the flow of data.

The backplane interface provides a versatile method of sending and receiving data from the host system. Elastic stores provide a method for interfacing to asynchronous systems, converting from a T1/E1 network to a 2.048MHz, 4.096MHz, 8.192MHz, or N x 64kHz system backplane. The elastic stores also manage slip conditions (asynchronous interface). An IBO is provided to allow multiple framers in the DS26524 to share a high-speed backplane.

8.9.1 T1 Framing

DS1 trunks contain 24 bytes of serial voice/data channels bundled with an overhead bit, the F-bit. The F-bit contains a fixed pattern for the receiver to delineate the frame boundaries. The F-bit is inserted once per frame at the beginning of the transmit frame boundary. The frames are further grouped into bundles of frames 12 for D4 and 24 for ESF.

The D4 and ESF framing modes are outlined in [Table 8-10](#) and [Table 8-11](#). In the D4 mode, framing bit for frame 12 is ignored if Japanese Yellow is selected.

Table 8-10. D4 Framing Mode

FRAME NUMBER	Ft	Fs	SIGNALING
1	1		
2		0	
3	0		
4		0	
5	1		
6		1	A
7	0		
8		1	
9	1		
10		1	
11	0		
12		0	B

Table 8-11. ESF Framing Mode

FRAME NUMBER	FRAMING	FDL	CRC	SIGNALING
1		√		
2			CRC-1	
3		√		
4	0			
5		√		
6			CRC-2	√
7		√		
8	0			
9		√		
10			CRC-3	
11		√		
12				√
13		√		
14			CRC-4	
15		√		
16	0			
17		√		√
18			CRC-5	
19		√		
20	1			
21		√		
22			CRC-6	
23		√		
24	1			√

Table 8-12. SLC-96 Framing

FRAME NUMBER	Ft	Fs	SIGNALING
1	1		
2		0	
3	0		
4		0	
5	1		
6		1	A
7	0		
8		1	
9	1		
10		1	
11	0		
12		0	B
13	1		
14		0	
15	0		
16		0	
17	1		
18		1	C
19	0		
20		1	
21	1		
22		1	
23	0		

FRAME NUMBER	Ft	Fs	SIGNALING
24		C1 (Concentrator Bit)	D
25	1		
26		C2 (Concentrator Bit)	
27	0		
28		C3 (Concentrator Bit)	
29	1		
30		C4 (Concentrator Bit)	A
31	0		
32		C5 (Concentrator Bit)	
33	1		
34		C6 (Concentrator Bit)	
35	0		
36		C7 (Concentrator Bit)	B
37	1		
38		C8 (Concentrator Bit)	
39	0		
40		C9 (Concentrator Bit)	
41	1		
42		C10 (Concentrator Bit)	C
43	0		
44		C11 (Concentrator Bit)	
45	1		
46		0 (Spoiler Bit)	
47	0		D
48		1 (Spoiler Bit)	
49	1		
50		0 (Spoiler Bit)	
51	0		
52		M1 (Maintenance Bit)	
53	1		
54		M2 (Maintenance Bit)	A
55	0		
56		M3 (Maintenance Bit)	
57	1		
58		A1 (Alarm Bit)	
59	0		
60		A2 (Alarm Bit)	B
61	1		
62		S1 (Switch Bit)	
63	0		
64		S2 (Switch Bit)	
65	1		C
66		S3 (Switch Bit)	
67	0		
68		S4 (Switch Bit)	
69	1		
70		1 (Spoiler Bit)	
71	0		
72		0	D

8.9.2 E1 Framing

The E1 framing consists of FAS, NFAS detection as shown in [Table 8-13](#).

Table 8-13. E1 FAS/NFAS Framing

CRC-4 FRAME #	TYPE	1	2	3	4	5	6	7	8
0	FAS	C1	0	0	1	1	0	1	1
1	NFAS	0	1	A	Sa4	Sa5	Sa6	Sa7	Sa8
2	FAS	C2	0	0	1	1	0	1	1
3	NFAS	0	1	A	Sa4	Sa5	Sa6	Sa7	Sa8
4	FAS	C3	0	0	1	1	0	1	1
5	NFAS	1	1	A	Sa4	Sa5	Sa6	Sa7	Sa8
6	FAS	C4	0	0	1	1	0	1	1
7	NFAS	0	1	A	Sa4	Sa5	Sa6	Sa7	Sa8
8	FAS	C1	0	0	1	1	0	1	1
9	NFAS	1	1	A	Sa4	Sa5	Sa6	Sa7	Sa8
10	FAS	C2	0	0	1	1	0	1	1
11	NFAS	1	1	A	Sa4	Sa5	Sa6	Sa7	Sa8
12	FAS	C3	0	0	1	1	0	1	1
13	NFAS	E1	1	A	Sa4	Sa5	Sa6	Sa7	Sa8
14	FAS	C4	0	0	1	1	0	1	1
15	NFAS	E2	1	A	Sa4	Sa5	Sa6	Sa7	Sa8

C = C bits are the CRC-4 remainder, A = alarm bits, Sa = bits for data link.

[Table 8-14](#) shows registers that are related to setting up the framing.

Table 8-14. Registers Related to Setting Up the Framer

REGISTER	FRAMER ADDRESSES	FUNCTION
Transmit Master Mode Register (TMMR)	180h	T1/E1 mode.
Transmit Control Register 1 (TCR1)	181h	Source of the F-bit.
Transmit Control Register 2 (TCR2)	182h	F-bit corruption, selection of SLC-96.
Transmit Control Register 3 (TCR3)	183h	ESF or D4 mode selection.
Receive Master Mode Register (RMMR)	080h	T1/E1 selection for receiver.
Receive Control Register 1 (RCR1)	081h	Resynchronization criteria for the framer.
Receive Control Register 2 (T1RCR2)	014h	T1 remote alarm and OOF criteria.
Receive Control Register 2 (E1RCR2)	082h	E1 receive loss of signal criteria selection.
Receive Latched Status Register 1 (RLS1)	090h	Receive latched status 1.
Receive Interrupt Mask Register 1 (RIM1)	0A0h	Receive interrupt mask 1.
Receive Latched Status Register 2 (RLS2)	091h	Receive latched status 2.
Receive Interrupt Mask Register 2 (RIM2)	0A1h	Receive interrupt mask 2.
Receive Latched Status Register 4 (RLS4)	093h	Receive latched status 4.
Receive Interrupt Mask Register 4 (RIM4)	0A3h	Receive interrupt mask 4.
Frames Out of Sync Count Register 1 (FOSCR1)	054h	Framer out of sync register 1.
Frames Out of Sync Count Register 2 (FOSCR2)	055h	Framer out of sync register 2.
E1 Receive Align Frame Register (E1RAF)	064h	RAF byte.
E1 Receive Non-Align Frame Register (E1RNAF)	065h	RNAF byte.
Transmit SLC-96 Data Link Register 1 (T1TSLC1)	164h	Transmit SLC-96 bits.
Transmit SLC-96 Data Link Register 2 (T1TSLC2)	165h	Transmit SLC-96 bits.
Transmit SLC-96 Data Link Register 3 (T1TSLC3)	166h	Transmit SLC-96 bits.
Receive SLC-96 Data Link Register 1 (T1RSLC1)	064h	Receive SLC-96 bits.
Receive SLC-96 Data Link Register 2 (T1RSLC2)	065h	Receive SLC-96 bits.
Receive SLC-96 Data Link Register 3 (T1RSLC3)	066h	Receive SLC-96 bits.

Note: The addresses shown are for Framer 1. Addresses for Framers 2 to 4 can be calculated using the following: Framer n = (Framer 1 address + $(n - 1) \times 200h$); where $n = 2$ to 4 for Framers 2 to 4.

8.9.3 T1 Transmit Synchronizer

The DS26524 transmitter can identify the D4 or ESF frame boundary, as well as the CRC multiframe boundaries within the incoming NRZ data stream at TSER. The TFM ([TCR3.2](#)) control bit determines whether the transmit synchronizer searches for the D4 or ESF multiframe. Additional control signals for the transmit synchronizer are located in the [TSYNCC](#) register. The latched status bit [TLS3.0](#) (LOFD) is provided to indicate that a loss-of-frame synchronization has occurred. The real-time bit (LOF) is also provided to indicate when the synchronizer is searching for frame/multiframe alignment. The LOFD bit can be enabled to cause an interrupt condition on [INTB](#).

Note that when the transmit synchronizer is used, the TSYNC signal should be set as an output (TSIO = 1) and the recovered frame-sync pulse will be output on this signal. The recovered CRC-4 multiframe sync pulse is output if enabled with [TIOCR.0](#) (TSM = 1).

Other key points concerning the E1 transmit synchronizer:

- 1) The Tx synchronizer is not operational when the transmit elastic store is enabled, including IBO modes.
- 2) The Tx synchronizer does not perform CRC-6 alignment verification (ESF mode) and does not verify CRC-4 codewords.

The Tx synchronizer cannot search for the CAS multiframe. [Table 8-15](#) shows the registers related to the transmit synchronizer.

Table 8-15. Registers Related to the Transmit Synchronizer

REGISTER	FRAMER ADDRESSES	FUNCTION
Transmit Synchronizer Control Register (TSYNCC)	18Eh	Resynchronization control for the transmit synchronizer.
Transmit Control Register 3 (TCR3)	183h	TFM bit selects between D4 and ESF for the transmit synchronizer.
Transmit Latched Status Register 3 (TLS3)	192h	Provides latched status for the transmit synchronizer.
Transmit Interrupt Mask Register 3 (TIM3)	1A2h	Provides mask bits for the TLS3 status.
Transmit I/O Configuration Register (TIOCR)	184h	TSYNC should be set as an output.

Note: The addresses shown are for Framer 1. Addresses for Framers 2 to 4 can be calculated using the following: Framer n = (Framer 1 address + $(n - 1) \times 200h$); where $n = 2$ to 4 for Framers 2 to 4.

8.9.4 Signaling

The DS26524 supports both software- and hardware-based signaling. Interrupts can be generated on changes of signaling data. The DS26524 is also equipped with receive-signaling freeze on loss of synchronization (OOF), carrier loss, or change of frame alignment. The DS26524 also has hardware pins to indicate signaling freeze.

- Flexible signaling support
 - Software or hardware based
 - Interrupt generated on change of signaling data
 - Receive-signaling freeze on loss of frame, loss of signal, or change of frame alignment
- Hardware pins for carrier loss and signaling freeze indication

Table 8-16. Registers Related to Signaling

REGISTER	FRAMER ADDRESSES	FUNCTION
Transmit-Signaling Registers 1 to 16 (TS1 to TS16)	140h to 14Bh (T1/J1) 140h to 14Fh (E1 CAS)	Transmit ABCD signaling.
Software-Signaling Insertion Enable Registers 1 to 4 (SSIE1 to SSIE4)	118h, 119h, 11Ah, 11Bh	When enabled, signaling is inserted for the channel.
Transmit Hardware-Signaling Channel Select Registers 1 to 4 (THSCS1 to THSCS4)	1C8h, 1C9h, 1CAh, 1CBh	Bits determine which channels will have signaling inserted in hardware-signaling mode.
Receive-Signaling Control Register (RSIGC)	013h	Freeze control for receive signaling.
Receive-Signaling All-Ones Insertion Registers 1 to 3 (T1RSAOI1 to T1RSAOI3)	038h, 039h, 03Ah	Registers for all-ones insertion (T1 mode only).
Receive-Signaling Registers 1 to 16 (RS1 to RS16)	040h to 04Bh (T1/J1) 040h to 04Fh (E1)	Receive-signaling bytes.
Receive-Signaling Status Registers 1 to 4 (RSS1 to RSS4)	098h to 09Ah (T1/J1) 98h to 9Fh (E1)	Receive-signaling change of status bits.
Receive-Signaling Change of State Enable Registers 1 to 4 (RSCSE1 to RSCSE4)	0A8h, 0A9h, 0AAh, 0ABh	Receive-signaling change of state interrupt enable.
Receive Latched Status Register 4 (RLS4)	093h	Receive-signaling change of state bit.
Receive Interrupt Mask Register 4 (RIM4)	0A3h	Receive-signaling change of state interrupt mask bit.
Receive-Signaling Reinsertion Enable Registers 1 to 4 (RSI1 to RSI4)	0C8h, 0C9h, 0CAh, 0CBh	Registers for signaling reinsertion.

Note: The addresses shown are for Framer 1. Addresses for Framers 2 to 4 can be calculated using the following: Framer n = (Framer 1 address + $(n - 1) \times 200h$); where $n = 2$ to 4 for Framers 2 to 4.

8.9.4.1 Transmit-Signaling Operation

There are two methods to provide transmit-signaling data. These are processor based (i.e., software based) or hardware based. Processor based refers to access through the transmit-signaling registers, [TS1:TS16](#), while hardware based refers to using the TSIG pins. Both methods can be used simultaneously.

8.9.4.1.1 Processor-Based Signaling

In processor-based mode, signaling data is loaded into the transmit-signaling registers ([TS1:TS16](#)) via the host interface. On multiframe boundaries, the contents of these registers are loaded into a shift register for placement in the appropriate bit position in the outgoing data stream. The user can use the transmit multiframe interrupt in Latched Status Register 1 ([TLS1.2](#)) to know when to update the signaling bits. The user need not update any transmit-signaling register for which there is no change of state for that register.

Each transmit-signaling register contains the robbed-bit signaling ([TCR1.4](#) in T1 mode) or TS16 CAS signaling ([TCR1.6](#) in E1 mode) for one time slot that will be inserted into the outgoing stream. Signaling data can be sourced from the TS registers on a per-channel basis by using the software-signaling insertion enable registers, [SSIE1:SSIE4](#).

In T1 ESF framing mode, there are four signaling bits per channel (A, B, C, and D). TS1:TS12 contain a full multiframe of signaling data. In T1 D4 framing mode, there are only two signaling bits per channel (A and B). In T1 D4 framing mode, the framer uses A and B bit positions for the next multiframe. The C and D bit positions become “don’t care” in D4 mode.

In E1 mode, TS16 carries the signaling information. This information can be in either CCS (common-channel signaling) or CAS (channel-associated signaling) format. The 32 time slots are referenced by two different channel number schemes in E1. In channel numbering, TS0 to TS31 are labeled channel 1 to channel 32. In phone channel numbering, TS1 to TS15 are labeled channel 1 to channel 15, and TS17 to TS31 are labeled channel 15 to channel 30.

8.9.4.2 Time Slot Numbering Schemes

TS	0	1	2	3	4	5	6	7	8	9	10	11	12	13	14	15	16	17	18	19	20	21	22	23	24	25	26	27	28	29	30	31
Channel	1	2	3	4	5	6	7	8	9	10	11	12	13	14	15	16	17	18	19	20	21	22	23	24	25	26	27	28	29	30	31	32
Phone Channel		1	2	3	4	5	6	7	8	9	10	11	12	13	14	15		16	17	18	19	20	21	22	23	24	25	26	27	28	29	30

8.9.4.2.1 Hardware-Based Signaling

In hardware-based mode, signaling data is input via the TSIG pin. This signaling PCM stream is buffered and inserted to the data stream being input at the TSER pin.

Signaling data can be input via the transmit hardware-signaling channel select ([THSCS1](#)) function. The framer can be set up to take the signaling data presented at the TSIG pin and insert the signaling data into the PCM data stream that is being input at the TSER pin. The user can control which channels are to have signaling data from the TSIG pin inserted into them on a per-channel basis. The signaling insertion capabilities of the framer are available whether the transmit-side elastic store is enabled or disabled. If the elastic store is enabled, the backplane clock (TSYSCLK) can be either 1.544MHz or 2.048MHz.

8.9.4.3 Receive-Signaling Operation

There are two methods to access receive-signaling data and provide transmit-signaling data: processor based (i.e., software based) or hardware based. Processor based refers to access through the transmit- and receive-signaling registers, [RS1:RS16](#). Hardware based refers to the RSIG pin. Both methods can be used simultaneously.

8.9.4.3.1 Processor-Based Signaling

Signaling information is sampled from the receive data stream and copied into the receive-signaling registers, [RS1:RS16](#). The signaling information in these registers is always updated on multiframe boundaries. This function is always enabled.

8.9.4.3.2 Change of State

To avoid constant monitoring of the receive-signaling registers, the DS26524 can be programmed to alert the host when any specific channel or channels undergo a change of their signaling state. [RSCSE1:RSCSE4](#) are used to select which channels can cause a change-of-state indication. The change of state is indicated in Latched Status Register 4 ([RLS4.3](#)). If signaling integration is enabled, the new signaling state must be constant for three multiframes before a change-of-state indication is indicated. The user can enable the $\overline{\text{INTB}}$ pin to toggle low upon detection of a change in signaling by setting the interrupt mask bit [RIM4.3](#). The signaling integration mode is global and cannot be enabled on a channel-by-channel basis.

The user can identify which channels have undergone a signaling change of state by reading the receive-signaling status ([RSS1:RSS4](#)) registers. The information from these registers tells the user which RSx register to read for the new signaling data. All changes are indicated in the [RSS1:RSS4](#) registers regardless of the [RSCSE1:RSCSE4](#) registers.

8.9.4.3.3 Hardware-Based Receive Signaling

In hardware-based signaling, the signaling data can be obtained from the RSER pin or the RSIG pin. RSIG is a signaling PCM stream output on a channel-by-channel basis from the signaling buffer. The T1 robbed bit or E1 TS16 signaling data is still present in the original data stream at RSER. The signaling buffer provides signaling data to the RSIG pin and also allows signaling data to be reinserted into the original data stream in a different alignment that is determined by a multiframe signal from the RSYNC pin. In this mode, the receive elastic store can be enabled or disabled. If the receive elastic store is enabled, the backplane clock (RSYSCLK) can be either 1.544MHz or 2.048MHz. In the ESF framing mode, the ABCD signaling bits are output on RSIG in the lower nibble of each channel. The RSIG data is updated once a multiframe (3ms for T1 ESF, 1.5ms for T1 D4, 2ms for E1 CAS) unless a signaling freeze is in effect. In the D4 framing mode, the AB signaling bits are output twice on RSIG in the lower nibble of each channel. Thus, bits 5 and 6 contain the same data as bits 7 and 8, respectively, in each channel.

8.9.4.3.4 Receive-Signaling Reinsertion at RSER

In this mode, the user provides a multiframe sync at the RSYNC pin and the signaling data will be reinserted based on this alignment. In T1 mode, this results in two copies of the signaling data in the RSER data stream. The original signaling data is based on the Fs/ESF frame positions, and the realigned data is based on the user-supplied multiframe sync applied at RSYNC. In voice channels, this extra copy of signaling data is of little consequence. Reinsertion can be avoided in data channels since this feature is activated on a per-channel basis. For reinsertion, the elastic store must be enabled; for T1, the backplane clock can be either 1.544MHz or 2.048MHz. E1 signaling information cannot be reinserted into a 1.544MHz backplane.

Signaling-reinsertion mode is enabled on a per-channel basis by setting the receive-signaling reinsertion channel select bit high in the Receive-Signaling Reinsertion Enable register ([RSI1:RSI4](#)). The channels that are to have signaling reinserted are selected by writing to the [RSI1:RSI4](#) registers. In E1 mode, the user generally selects all channels or none for reinsertion.

8.9.4.3.5 Force Receive-Signaling All Ones

In T1 mode, the user can, on a per-channel basis, force the robbed-bit signaling bit positions to 1. This is done by using the T1-mode Receive-Signaling All-Ones Insertion registers ([T1RSAOI1:T1RSAOI3](#)). The user sets the channel select bit in the [T1RSAOI1:T1RSAOI3](#) registers to select the channels that are to have the signaling forced to one.

8.9.4.3.6 Receive-Signaling Freeze

The signaling data in the four multiframe signaling buffers is frozen in a known good state upon either a loss of synchronization (OOF event), carrier loss, or change of frame alignment. In T1 mode, this action meets the requirements of BellCore TR-TSY-000170 for signaling freezing. To allow this freeze action to occur, the RSFE control bit ([RSIGC.1](#)) should be set high. The user can force a freeze by setting the RSFF control bit ([RSIGC.2](#)) high. The RSIGF output pin provides a hardware indication that a freeze is in effect. The four multiframe buffer provides a three multiframe delay in the signaling bits provided at the RSIG pin (and at the RSER pin if receive-signaling reinsertion is enabled). When freezing is enabled (RSFE = 1), the signaling data is held in the last known good state until the corrupting error condition subsides. When the error condition subsides, the signaling data is held in the old state for at least an additional 9ms (4.5ms in D4 framing mode, 6ms for E1 mode) before being allowed to be updated with new signaling data.

The receive-signaling registers are frozen and not updated during a loss-of-sync condition. They will contain the most recent signaling information before the LOF occurred.

8.9.4.4 Transmit SLC-96 Operation (T1 Mode Only)

In an SLC-96-based transmission scheme, the standard Fs-bit pattern is robbed to make room for a set of message fields. The SLC-96 multiframe is made up of six D4 superframes, thus it is 72 frames long. In the 72-frame SLC-96 multiframe, 36 of the framing bits are the normal Ft pattern and the other 36 bits are divided into alarm, maintenance, spoiler, and concentrator bits, as well as 12 bits of the normal Fs pattern. Additional SLC-96 information can be found in BellCore document TR-TSY-000008. Registers related to the transmit FDL are shown in [Table 8-17](#).

Table 8-17. Registers Related to SLC-96

REGISTER	FRAMER ADDRESSES	FUNCTION
Transmit FDL Register (T1TFDL)	162h	For sending messages in transmit SLC-96 Ft/Fs bits.
Transmit SLC-96 Data Link Registers 1 to 3 (T1TSLC1:T1TSLC3)	164h, 165h, 166h	Registers that control the SLC-96 overhead values.
Transmit Control Register 2 (TCR2)	182h	Transmit control for data selection source for the Ft/Fs bits.
Transmit Latched Status Register 1 (TLS1)	190h	Status bit for indicating transmission of data link buffer.
Receive SLC-96 Data Link Registers 1 to 3 (T1RSLC1:T1RSLC3)	064h, 065h, 066h	—
Receive Latched Status Register 7 (RLS7)	096h	Receive SLC-96 alignment event.

Note: The addresses shown are for Framer 1. Addresses for Framers 2 to 4 can be calculated using the following: Framer $n = (\text{Framer 1 address} + (n - 1) \times 200\text{h})$; where $n = 2$ to 4 for Framers 2 to 4.

The [T1TFDL](#) register is used to insert the SLC-96 message fields. To insert the SLC-96 message using the [T1TFDL](#) register, the user should configure the DS26524 as shown:

- [TCR2.6](#) (TSLC96) = 1 Enable transmit SLC-96.
- [TCR2.7](#) (TFDLS) = 0 Source FS bits via TFDL or SLC-96 formatter.
- [TCR3.2](#) (TFM) = 1 D4 framing mode.
- [TCR1.6](#) (TFPT) = 0 Do not “pass through” TSER F-bits.

The DS26524 automatically inserts the 12-bit alignment pattern in the Fs bits for the SLC-96 data link frame. Data from [T1TSLC1:T1TSLC3](#) is inserted into the remaining Fs-bit locations of the SLC-96 multiframe. The status bit TSLC96 located at [TLS1.4](#) is set to indicate that the SLC-96 data link buffer has been transmitted and that the user should write new message data into [T1TSLC1:T1TSLC3](#). The host has 9ms after the assertion of TLS1.4 to write the registers [T1TSLC1:T1TSLC3](#). If no new data is provided in these registers, the previous values are retransmitted.

8.9.4.5 Receive SLC-96 Operation (T1 Mode Only)

In an SLC-96-based transmission scheme, the standard Fs-bit pattern is robbed to make room for a set of message fields. The SLC-96 multiframe is made up of six D4 superframes, thus it is 72 frames long. In the 72-frame SLC-96 multiframe, 36 of the framing bits are the normal Ft pattern and the other 36 bits are divided into alarm, maintenance, spoiler, and concentrator bits, as well as 12 bits of the normal Fs pattern. Additional SLC-96 information can be found in BellCore document TR-TSY-000008.

To enable the DS26524 to synchronize onto a SLC-96 pattern, the following configuration should be used:

- [RCR1.5](#) (RFM) = 1 Set to D4 framing mode.
- [RCR1.3](#) (SYNCC) = 1 Set to cross-couple Ft and Fs bits.
- [T1RCR2.4](#) (RSLC96) = 1 Enable SLC-96 synchronizer.
- [RCR1.7](#) (SYNCT) = 0 Set to minimum sync time.

The SLC-96 message bits can be extracted via the [T1RSLC1:T1RSLC3](#) registers. The status bit RSLC96 located at [RLS7.3](#) is useful for retrieving SLC-96 message data. The RSLC96 bit indicates when the framer has updated the data link registers [T1RSLC1:T1RSLC3](#) with the latest message data from the incoming data stream. Once the RSLC96 bit is set, the user has 9ms (or until the next RSLC96 interrupt) to retrieve the most recent message data from the [T1RSLC1:T1RSLC3](#) registers. Note that RSLC96 will not set if the DS26524 is unable to detect the 12-bit SLC-96 alignment pattern.

8.9.5 T1 Data Link

8.9.5.1 T1 Transmit Bit-Oriented Code (BOC) Transmit Controller

The DS26524 contains a BOC generator on the transmit side and a BOC detector on the receive side. The BOC function is available only in T1 mode. [Table 8-18](#) shows the registers related to the transmit bit-oriented code.

Table 8-18. Registers Related to T1 Transmit BOC

REGISTER	FRAMER ADDRESSES	FUNCTION
Transmit BOC Register (T1TBOC)	163h	Transmit bit-oriented message code register.
Transmit HDLC Control Register 2 (THC2)	113h	Bit to enable sending of transmit BOC.
Transmit Control Register 1 (TCR1)	181h	Determines the sourcing of the F-bit.

Note: The addresses shown are for Framer 1. Addresses for Framers 2 to 4 can be calculated using the following: Framer n = (Framer 1 address + $(n - 1) \times 200h$); where $n = 2$ to 4 for Framers 2 to 4.

Bits 0 to 5 in the [T1TBOC](#) register contain the BOC message to be transmitted. Setting SBOC = 1 ([THC2.6](#)) causes the transmit BOC controller to immediately begin inserting the BOC sequence into the FDL bit position. The transmit BOC controller automatically provides the abort sequence. BOC messages will be transmitted as long as SBOC is set. Note that the TFPT ([TCR1.6](#)) control bit must be set to 0 for the BOC message to overwrite F-bit information being sampled on TSER.

8.9.5.1.1 To Transmit a BOC

- 1) Write 6-bit code into the [T1TBOC](#) register.
- 2) Set SBOC bit in [THC2](#) = 1.

8.9.5.2 Receive Bit-Oriented Code (BOC) Controller

The DS26524 framers contain a BOC generator on the transmit side and a BOC detector on the receive side. The BOC function is available only in T1, ESF mode in the data link bits. [Table 8-19](#) shows the registers related to the receive BOC operation.

Table 8-19. Registers Related to T1 Receive BOC

REGISTER	FRAMER ADDRESSES	FUNCTION
Receive BOC Control Register (T1RBOCC)	015h	Controls the receive BOC function.
Receive BOC Register (T1RBOC)	063h	Receive bit-oriented message.
Receive Latched Status Register 7 (RLS7)	096h	Indicates changes to the receive bit-oriented messages.
Receive Interrupt Mask Register 7 (RIM7)	0A6h	Mask bits for RBOC for generation of interrupts.

Note: The addresses shown are for Framer 1. Addresses for Framers 2 to 4 can be calculated using the following: Framer $n = (\text{Framer 1 address} + (n - 1) \times 200h)$; where $n = 2$ to 4 for Framers 2 to 4.

In ESF mode, the DS26524 continuously monitors the receive message bits for a valid BOC message. The BOC detect (BD) status bit at [RLS7.0](#) is set once a valid message has been detected for a time determined by the receive BOC filter bits RBF0 and RBF1 in the [T1RBOCC](#) register. The 6-bit BOC message is available in the [T1RBOC](#) register. Once the user has cleared the BD bit, it remains clear until a new BOC is detected (or the same BOC is detected following a BOC clear event). The BOC clear (BC) bit at [RLS7.1](#) is set when a valid BOC is no longer being detected for a time determined by the receive BOC disintegration bits RBD0 and RBD1 in the [T1RBOCC](#) register.

The BD and BC status bits can create a hardware interrupt on the $\overline{\text{INTB}}$ signal as enabled by the associated interrupt mask bits in the [RIM7](#) register.

8.9.5.3 Legacy T1 Transmit FDL

It is recommended that the DS26524's built-in BOC or HDLC controllers be used for most applications requiring access to the FDL. [Table 8-21](#) shows the registers related to control of the transmit FDL.

Table 8-20. Registers Related to T1 Transmit FDL

REGISTER	FRAMER ADDRESSES	FUNCTION
Transmit FDL Register (T1TFDL)	162h	FDL code used to insert transmit FDL.
Transmit Control Register 2 (TCR2)	182h	Defines the source of the FDL.
Transmit Latched Status Register 2 (TLS2)	191h	Transmit FDL empty bit.
Transmit Interrupt Mask Register 2 (HDLC) (TIM2)	1A1h	Mask bit for TFDL empty.

Note: The addresses shown are for Framer 1. Addresses for Framers 2 to 4 can be calculated using the following: Framer $n = (\text{Framer 1 address} + (n - 1) \times 200h)$; where $n = 2$ to 4 for Framers 2 to 4.

When enabled with [TCR2.7](#), the transmit section shifts out into the T1 data stream either the FDL (in the ESF framing mode) or the Fs bits (in the D4 framing mode) contained in the Transmit FDL register ([T1TFDL](#)). When a new value is written to the [T1TFDL](#), it is multiplexed serially (LSB first) into the proper position in the outgoing T1 data stream. After the full eight bits have been shifted out, the framer signals the host controller that the buffer is empty and that more data is needed by setting the [TLS2.4](#) bit to a 1. The $\overline{\text{INTB}}$ bit also toggles low if enabled via [TIM2.4](#). The user has 2ms to update the [T1TFDL](#) with a new value. If the [T1TFDL](#) is not updated, the old value in the [T1TFDL](#) is transmitted once again. Note that in this mode, no zero stuffing is applied to the FDL data. It is strongly suggested that the HDLC controller be used for FDL messaging applications.

In the D4 framing mode, the framer uses the [T1TFDL](#) register to insert the Fs framing pattern. To accomplish this, the [T1TFDL](#) register must be programmed to 1Ch and [TCR2.7](#) should be set to 0 (source Fs data from the [T1TFDL](#) register).

The Transmit FDL register ([T1TFDL](#)) contains the facility data link (FDL) information that is to be inserted on a byte basis into the outgoing T1 data stream. The LSB is transmitted first. In D4 mode, only the lower six bits are used.

8.9.5.4 Legacy T1 Receive FDL

It is recommended that the DS26524's built-in BOC or HDLC controllers be used for most applications requiring access to the FDL. [Table 8-21](#) shows the registers related to the receive FDL.

Table 8-21. Registers Related to T1 Receive FDL

REGISTER	FRAMER ADDRESSES	FUNCTION
Receive FDL Register (T1RFDL)	062h	FDL code used to insert transmit FDL.
Receive Latched Status Register 7(RLS7)	096h	Receive FDL full bit is in this register.
Receive Interrupt Mask Register 7(RIM7)	0A6h	Mask bit for RFDL full.

Note: The addresses shown are for Framer 1. Addresses for Framers 2 to 4 can be calculated using the following: Framer n = (Framer 1 address + $(n - 1) \times 200h$); where $n = 2$ to 4 for Framers 2 to 4.

In the receive section, the recovered FDL bits or Fs bits are shifted bit-by-bit into the Receive FDL register ([T1RFDL](#)). Since the [T1RFDL](#) is 8 bits in length, it fills up every 2ms ($8 \times 250\mu s$). The framer signals an external controller that the buffer has filled via the [RLS7.2](#) bit. If enabled via [RIM7.2](#), the \overline{INTB} pin toggles low, indicating that the buffer has filled and needs to be read. The user has 2ms to read this data before it is lost. Note that no zero destuffing is applied for the data provided through the [T1RFDL](#) register. The [T1RFDL](#) reports the incoming facility data link (FDL) or the incoming Fs bits. The LSB is received first. In D4 framing mode, [T1RFDL](#) updates on multiframe boundaries and reports only the Fs bits.

8.9.6 E1 Data Link

[Table 8-22](#) shows the registers related to E1 data link.

Table 8-22. Registers Related to E1 Data Link

REGISTER	FRAMER ADDRESSES	FUNCTION
E1 Receive Align Frame Register (E1RAF)	064h	Receive frame alignment register.
E1 Receive Non-Align Frame Register Register (E1RNAF)	065h	Receive non-frame alignment register.
E1 Received Si Bits of the Align Frame Register (E1RSiAF)	066h	Receive Si bits of the frame alignment frames.
Received Si Bits of the Non-Align Frame Register (E1RSiNAF)	067h	Receive Si bits of the non-frame alignment frames.
Received Sa4 to Sa8 Bits Register (E1RSa4 to E1RSa8)	069h, 06Ah, 06Bh, 06Ch, 06Dh	Receive Sa bits.
Transmit Align Frame Register (E1TAF)	164h	Transmit align frame register.
Transmit Non-Align Frame Register (E1TNAF)	165h	Transmit non-align frame register.
Transmit Si Bits of the Align Frame Register (E1TSiAF)	166h	Transmit Si bits of the frame alignment frames.
Transmit Si Bits of the Non-Align Frame Register (E1TSiNAF)	167h	Transmit Si bits of the non-frame alignment frames.
Transmit Sa4 to Sa8 Bits Register (E1TSa4 to E1TSa8)	169h, 16Ah, 16Bh, 16Ch, 16Dh	Transmit Sa4 to Sa8.
E1 Transmit Sa-Bit Control Register (E1TSACR)	114h	Transmit sources of Sa control.

Note: The addresses shown are for Framer 1. Addresses for Framers 2 to 4 can be calculated using the following: Framer n = (Framer 1 address + $(n - 1) \times 200h$); where $n = 2$ to 4 for Framers 2 to 4.

8.9.6.1 Additional E1 Receive Sa- and Si-Bit Receive Operation (E1 Mode)

The DS26524, when operated in the E1 mode, provides for access to both the Sa and the Si bits via two methods. The first involves using the internal [E1RAF/E1RNAF](#) and [E1TAF/E1TNAF](#) registers. The second method involves an expanded version of the first method.

8.9.6.1.1 Internal Register Scheme Based on Double-Frame (Method 1)

On the receive side, the [E1RAF](#) and [E1RNAF](#) registers will always report the data as it received in the Sa- and Si-bit locations. The [E1RAF](#) and [E1RNAF](#) registers are updated on align frame boundaries. The setting of the receive align frame bit in Receive Latched Status Register 2 ([RLS2.0](#)) indicates that the contents of the RAF and RNAF have been updated. The host can use the [RLS2.0](#) bit to know when to read the [E1RAF](#) and [E1RNAF](#) registers. The host has 250µs to retrieve the data before it is lost.

8.9.6.1.2 Internal Register Scheme Based on CRC-4 Multiframe (Receive Side)

On the receive side there is a set of eight registers ([E1RSiAF](#), [E1RSiNAF](#), [E1RRA](#), [E1RSa4:E1RSa8](#)) that report the Si and Sa bits as they are received. These registers are updated with the setting of the receive CRC-4 multiframe bit in Receive Latched Status Register 2 ([RLS2.1](#)). The host can use the [RLS2.1](#) bit to know when to read these registers. The user has 2ms to retrieve the data before it is lost. See the register descriptions for additional information.

8.9.6.1.3 Internal Register Scheme Based on CRC-4 Multiframe (Transmit Side)

On the transmit side there is a set of eight registers ([E1TSiAF](#), [E1TSiNAF](#), [E1TRA](#), [E1TSa4:E1TSa8](#)) that, via the Transmit Sa-Bit Control register ([E1TSACR](#)), can be programmed to insert both Si and Sa data. Data is sampled from these registers with the setting of the transmit multiframe bit in Transmit Latched Status Register 1 ([TLS1.3](#)). The host can use the [TLS1.3](#) bit to know when to update these registers. It has 2ms to update the data or else the old data will be retransmitted. See the register descriptions for additional information.

8.9.6.2 Sa-Bit Monitoring and Reporting

In addition to the registers outlined above, the DS26524 provides status and interrupt capability in order to detect changes in the state of selected Sa bits. The [E1RSAIMR](#) register can be used to select which Sa bits are monitored for a change of state. When a change of state is detected in one of the enabled Sa-bit positions, a status bit is set in the [RLS7](#) register via the SaXCD bit (bit 0). This status bit can, in turn, be used to generate an interrupt by unmasking [RIM7.0](#) (SaXCD). If multiple Sa bits have been enabled, the user can read the [SaBITS](#) register at address 06Eh to determine the current value of each Sa bit.

For the Sa6 bits, additional support is available to detect specific codewords per ETS 300 233. The [Sa6CODE](#) register reports the received Sa6 codeword. The codeword must be stable for a period of three submultiframes and be different from the previous stored value in order to be updated in this register. See the [Sa6CODE](#) register description for further details on the operation of this register and the values reported in it. An additional status bit is provided in [RLS7](#) (Sa6CD) to indicate if the received Sa6 codeword has changed. A mask bit is provided for this status bit in [RIM7](#) to allow for interrupt generation when enabled.

8.9.7 Maintenance and Alarms

The DS26524 provides extensive functions for alarm detection and generation. It also provides diagnostic functions for monitoring of performance and sending of diagnostic information such as the following:

- Real-time and latched status bits, interrupts, and interrupt mask for transmitter and receiver
- LOS detection
- RIA detection and generation
- PDV violation detection
- Error counters
- DS0 monitoring
- Milliwatt generation and detection
- Slip buffer status for transmit and receive

[Table 8-23](#) shows some of the registers related to maintenance and alarms.

Table 8-23. Registers Related to Maintenance and Alarms

REGISTER	FRAMER ADDRESSES	FUNCTION
Receive Real-Time Status Register 1 (RRTS1)	0B0h	Real-time receive status 1.
Receive Interrupt Mask Register 1(RIM1)	0A0h	Real-time interrupt mask 1.
Receive Latched Status Register 2 (RLS2)	091h	Real-time latched status 2.
Receive Real-Time Status Register 3 (RRTS3)	0B2h	Real-time receive status 2.
Receive Latched Status Register 3 (RLS3)	092h	Real-time latched status 3.
Receive Interrupt Mask Register 3 (RIM3)	0A2h	Real-time interrupt mask 3.
Receive Interrupt Mask Register 4 (RIM4)	0A3h	Real-time interrupt mask 3.
Receive Latched Status Register 7 (RLS7)	096h	Real-time latched status 7.
Receive Interrupt Mask Register 7 (RIM7)	0A6h	Real-time interrupt mask 7.
Transmit Latched Status Register 1 (TLS1)	190h	Loss of transmit clock status, TPDV, etc.
Transmit Latched Status Register 3 (Synchronizer) (TLS3)	192h	Loss of frame status.
Receive DS0 Monitor Register (RDS0M)	060h	Receive DS0 monitor.
Error-Counter Configuration Register (ERCNT)	086h	Configuration of the error counters.
Line Code Violation Count Register 1 (LCVCR1)	050h	Line code violation counter 1.
Line Code Violation Count Register 2 (LCVCR2)	051h	Line code violation counter 2.
Path Code Violation Count Register 1 (PCVCR1)	052h	Receive path code violation counter 1.
Path Code Violation Count Register 2 (PCVCR2)	053h	Receive path code violation counter 2.
Frames Out of Sync Count Register 1 (FOSCR1)	054h	Receive frame out of sync counter 1
Frames Out of Sync Count Register 2 (FOSCR2)	055h	Receive frame out of sync counter 2
E-Bit Count Register 1 (E1EBCR1)	056h	E-bit count register 1.
E-Bit Count Register 2 (E1EBCR2)	057h	E-bit count register 2.

Note: The addresses shown are for Framer 1. Addresses for Framers 2 to 4 can be calculated using the following: Framer n = (Framer 1 address + $(n - 1) \times 200h$); where $n = 2$ to 4 for Framers 2 to 4.

8.9.7.1 Status and Information Bit Operation

When a particular event has occurred (or is occurring), the appropriate bit in one of these registers is set to 1. Status bits can operate in either a latched or real-time fashion. Some latched bits can be enabled to generate a hardware interrupt via the $\overline{\text{INTB}}$ signal.

8.9.7.1.1 Real-Time Bits

Some status bits operate in a real-time fashion. These bits are read-only and indicate the present state of an alarm or a condition. Real-time bits remain stable and valid during the host read operation. The current value of the internal status signals can be read at any time from the real-time status registers without changing any the latched status register bits.

8.9.7.1.2 Latched Bits

When an event or an alarm occurs and a latched bit is set to 1, it remains set until cleared by the user. These bits typically respond on a change-of-state for an alarm, condition, or event, and operate in a read-then-write fashion. The user should read the value of the desired status bit and then write a 1 to that particular bit location to clear the latched value (write a 0 to locations not to be cleared). Once the bit is cleared, it is not set again until the event has occurred again.

8.9.7.1.3 Mask Bits

Some of the alarms and events can be either masked or unmasked from the interrupt pin via the Receive Interrupt Mask registers ([RIM1:RIM7](#)). When unmasked, the $\overline{\text{INTB}}$ signal is forced low when the enabled event or condition occurs. The $\overline{\text{INTB}}$ pin is allowed to return high (if no other unmasked interrupts are present) when the user reads and then clears (with a write) the alarm bit that caused the interrupt to occur. Note that the latched status bit and the $\overline{\text{INTB}}$ pin clear even if the alarm is still present.

Note that some conditions can have multiple status indications. For example, receive loss of frame (RLOF) provides the following indications:

RRTS1.0 (RLOF)	Real-time indication that the receiver is not synchronized with incoming data stream. Read-only bit that remains high as long as the condition is present.
RLS1.0 (RLOFD)	Latched indication that the receiver has lost synchronization since the bit was last cleared. Bit clears when written by the user, even if the condition is still present (rising edge detect of RRTS1.0).
RLS1.4 (RLOFC)	Latched indication that the receiver has reacquired synchronization since the bit was last cleared. Bit clears when written by the user, even if the condition is still present (falling edge detect of RRTS1.0).

Table 8-24. T1 Alarm Criteria

ALARM		SET CRITERIA	CLEAR CRITERIA
AIS (Blue Alarm) (See Note 1)		When over a 3ms window, 4 or fewer zeros are received.	When over a 3ms window, 5 or more zeros are received.
RAI (Yellow Alarm)	1) D4 Bit 2 Mode (T1RCR2.0 = 0)	When bit 2 of 256 consecutive channels is set to zero for at least 254 occurrences.	When bit 2 of 256 consecutive channels is set to zero for less than 254 occurrences.
	2) D4 12th F-Bit Mode (T1RCR2.0 = 1) (Note: This mode is also referred to as the "Japanese Yellow Alarm.")	When the 12th framing bit is set to one for two consecutive occurrences.	When the 12th framing bit is set to zero for two consecutive occurrences.
	3) ESF Mode	When 16 consecutive patterns of 00FF appear in the FDL.	When 14 or fewer patterns of 00FF hex out of 16 possible appear in the FDL.
LOS (Loss of Signal) (Note: This alarm is also referred to as receive carrier loss (RCL).)		When 192 consecutive zeros are received.	When 14 or more ones out of 112 possible bit positions are received starting with the first one received.

Note 1: The definition of the Alarm Indication Signal (Blue Alarm) is an unframed all-ones signal. AIS detectors should be able to operate properly in the presence of a 10E-3 error rate and they should not falsely trigger on a framed all-ones signal. The AIS alarm criteria in the DS26524 has been set to achieve this performance. It is recommended that the RAIS bit be qualified with the RLOF bit.

Note 2: The following terms are equivalent:
 RAIS = Blue Alarm
 RLOS = RCL
 RLOF = Loss of Frame (conventionally RLOS for Dallas Semiconductor devices)
 RRAI = Yellow Alarm

8.9.8 E1 Automatic Alarm Generation

The device can be programmed to automatically transmit AIS or remote alarm. When automatic AIS generation is enabled ([TCR2.6](#) = 1), the device monitors the receive-side framer to determine if any of the following conditions are present: loss of receive frame synchronization, AIS alarm (all ones) reception, or loss of receive carrier (or signal). If any one (or more) of these conditions is present, the framer forces an AIS.

When automatic RAI generation is enabled ([TCR2.5](#) = 1), the framer monitors the receive side to determine if any of the following conditions are present: loss of receive frame synchronization, AIS alarm (all ones) reception, loss of receive carrier (or signal), or if CRC-4 multiframe synchronization cannot be found within 128ms of FAS synchronization (if CRC-4 is enabled). If any one (or more) of the above conditions is present, the framer transmits an RAI alarm. RAI generation conforms to ETS 300 011 and ITU-T G.706 specifications.

Note: It is an illegal state to have both automatic AIS generation and automatic remote alarm generation enabled at the same time.

8.9.8.1 Receive AIS-CI and RAI-CI Detection

AIS-CI is a repetitive pattern of 1.26 seconds. It consists of 1.11 seconds of an unframed all-ones pattern and 0.15 seconds of all ones modified by the AIS-CI signature. The AIS-CI signature is a repetitive pattern 6176 bits in length in which, if the first bit is numbered bit 0, bits 3088, 3474, and 5790 are logical zeros and all other bits in the pattern are logical ones (T1.403). AIS-CI is an unframed pattern, so it is defined for all T1 framing formats. The RAIS-CI bit is set when the AIS-CI pattern has been detected and RAIS ([RRTS1.2](#)) is set. RAIS-CI is a latched bit that should be cleared by the host when read. RAIS-CI continues to set approximately every 1.2 seconds that the condition is present. The host needs to poll the bit in conjunction with the normal AIS indicators to determine when the condition has cleared.

RAI-CI is a repetitive pattern within the ESF data link with a period of 1.08 seconds. It consists of sequentially interleaving 0.99 seconds of “00000000 11111111” (right-to-left) with 90ms of “00111110 11111111.” The RRAI-CI bit is set when a bit-oriented code of “00111110 11111111” is detected while RRAI ([RRTS1.3](#)) is set. The RRAI-CI detector uses the receive BOC filter bits (RBF0 and RBF1) located in RBOCC to determine the integration time for RAI-CI detection. Like RAIS-CI, the RRAI-CI bit is latched and should be cleared by the host when read. RRAI-CI continues to set approximately every 1.1 seconds that the condition is present. The host needs to poll the bit in conjunction with the normal RAI indicators to determine when the condition has cleared. It may be useful to enable the 200ms ESF RAI integration time with the RAIE control bit ([T1RCR2.1](#)) in networks that use RAI-CI.

8.9.8.2 T1 Receive-Side Digital Milliwatt Code Generation

Receive-side digital milliwatt code generation involves using the T1 Receive Digital Milliwatt registers ([T1RDMWE1:T1RDMWE3](#)) to determine which of the 24 T1 channels of the T1 line going to the backplane should be overwritten with a digital milliwatt pattern. The digital milliwatt code is an 8-byte repeating pattern that represents a 1kHz sine wave (1E/0B/0B/1E/9E/8B/8B/9E). Each bit in the [T1RDMWE1](#), [T1RDMWE2](#), and [T1RDMWE3](#) registers represents a particular channel. If a bit is set to 1, the receive data in that channel is replaced with the digital milliwatt code. If a bit is set to 0, no replacement occurs.

8.9.9 Error-Count Registers

The DS26524 contains four counters that are used to accumulate line coding errors, path errors, and synchronization errors. Counter update options include one-second boundaries, 42ms (T1 mode only), 62.5ms (E1 mode only), or manually. See the Error-Counter Configuration register ([ERCNT](#)). When updated automatically, the user can use the interrupt from the timer to determine when to read these registers. All four counters saturate at their respective maximum counts and they will not roll over. (**Note:** Only the Line Code Violation Count register has the potential to overflow, but the bit error would have to exceed 10E-2 before this would occur.)

The DS26524 can share the one-second timer from Port 1 across all ports. All DS26524 error/performance counters can be configured to update on the shared one-second source, or a separate manual update signal input. See the Error-Counter Configuration register [ERCNT](#) register for more information. By allowing multiple framer cores to synchronously latch their counters, the host software can be streamlined to read and process performance information from multiple spans in a more controlled manner.

8.9.9.1 Line Code Violation Count Register (LCVCR)

Either bipolar violations or code violations can be counted. Bipolar violations are defined as consecutive marks of the same polarity. In T1 mode, if the B8ZS mode is set for the receive side, then B8ZS codewords are not counted as BPVs. In E1 mode, if the HDB3 mode is set for the receive side, then HDB3 codewords are not counted as BPVs. If [ERCNT.0](#) is set, then the LCVCR counts code violations as defined in ITU-T O.161. Code violations are defined as consecutive bipolar violations of the same polarity. In most applications, the framer should be programmed to count BPVs when receiving AMI code and to count CVs when receiving B8ZS or HDB3 code. This counter increments at all times and is not disabled by loss of sync conditions. The counter saturates at 65,535 and will not rollover. The bit-error rate on an E1 line would have to be greater than 10E-2 before the PCVCR would saturate. See [Table 8-25](#) and [Table 8-26](#) for details of exactly what the LCVCRs count.

Table 8-25. T1 Line Code Violation Counting Options

COUNT EXCESSIVE ZEROS? (ERCNT.0)	B8ZS ENABLED? (RCR1.6)	WHAT IS COUNTED IN LCVCR1 , LCVCR2
No	No	BPVs
Yes	No	BPVs + 16 consecutive zeros
No	Yes	BPVs (B8ZS/HDB3 codewords not counted)
Yes	Yes	BPVs + 8 consecutive zeros

Table 8-26. E1 Line Code Violation Counting Options

E1 CODE VIOLATION SELECT (ERCNT.0)	WHAT IS COUNTED IN LCVCR1 , LCVCR2
0	BPVs
1	CVs

8.9.9.2 Path Code Violation Count Register (PCVCR)

In T1 operation, the Path Code Violation Count register (PCVCR) records either Ft, Fs, or CRC-6 errors. When the receive side of a framer is set to operate in the T1 ESF framing mode, PCVCR records errors in the CRC-6 codewords. When set to operate in the T1 D4 framing mode, PCVCR counts errors in the Ft framing bit position. Via the [ERCNT.2](#) bit, a framer can be programmed to also report errors in the Fs framing bit position. PCVCR is disabled during receive loss of synchronization (RLOF = 1) conditions. See [Table 8-27](#) for a detailed description of exactly what errors the PCVCR counts in T1 operation.

In E1 operation, PCVCR records CRC-4 errors. Since the maximum CRC-4 count in a one-second period is 1000, this counter cannot saturate. The counter is disabled during loss of sync at either the FAS or CRC-4 level; it continues to count if loss of multiframe sync occurs at the CAS level.

The Path Code Violation Count Register 1 ([PCVCR1](#)) is the most significant word and Path Code Violation Count Register 2 ([PCVCR2](#)) is the least significant word of a 16-bit counter that records path violations (PVs).

Table 8-27. T1 Path Code Violation Counting Arrangements

FRAMING MODE	COUNT Fs ERRORS?	WHAT IS COUNTED IN PCVCR1 , PCVCR2
D4	No	Errors in the Ft pattern
D4	Yes	Errors in both the Ft and Fs patterns
ESF	Don't Care	Errors in the CRC-6 codewords

8.9.9.3 Frames Out of Sync Count Register (FOSCR)

The FOSCR is used to count the number of multiframes that the receive synchronizer is out of sync. This number is useful in ESF applications needing to measure the parameters loss of frame count (LOFC) and ESF error events as described in AT&T publication TR54016. When the FOSCR is operated in this mode, it is not disabled during receive loss of synchronization (RLOF = 1) conditions. The FOSCR has an alternate operating mode whereby it will count either errors in the Ft framing pattern (in the D4 mode) or errors in the FPS framing pattern (in the ESF mode). When the FOSCR is operated in this mode, it is disabled during receive loss of synchronization (RLOF = 1) conditions. See [Table 8-28](#) for a detailed description of what the FOSCR is capable of counting.

In E1 mode, the FOSCR counts word errors in the frame alignment signal in time slot 0. This counter is disabled when RLOF is high. FAS errors will not be counted when the framer is searching for FAS alignment and/or synchronization at either the CAS or CRC-4 multiframe level. Since the maximum FAS word error count in a one-second period is 4000, this counter cannot saturate.

The Frames Out of Sync Count Register 1 ([FOSCR1](#)) is the most significant word and Frames Out of Sync Count Register 2 ([FOSCR2](#)) is the least significant word of a 16-bit counter that records frames out of sync.

Table 8-28. T1 Frames Out of Sync Counting Arrangements

FRAMING MODE (RCR1.5)	COUNT MOS OR F-BIT ERRORS (ERCNT.1)	WHAT IS COUNTED IN FOSCR1 , FOSCR2
D4	MOS	Number of multiframes out of sync
D4	F-Bit	Errors in the Ft pattern
ESF	MOS	Number of multiframes out of sync
ESF	F-Bit	Errors in the FPS pattern

8.9.9.4 E-Bit Counter (EBCR)

This counter is only available in E1 mode. E-Bit Count Register 1 ([E1EBCR1](#)) is the most significant word and E-Bit Count Register 2 ([E1EBCR2](#)) is the least significant word of a 16-bit counter that records far-end block errors (FEBE) as reported in the first bit of frames 13 and 15 on E1 lines running with CRC-4 multiframe. These count registers increment once each time the received E-bit is set to 0. Since the maximum E-bit count in a one-second period is 1000, this counter cannot saturate. The counter is disabled during loss of sync at either the FAS or CRC-4 level; it continues to count if loss of multiframe sync occurs at the CAS level.

8.9.10 DS0 Monitoring Function

The DS26524 can monitor one DS0 (64kbps) channel in the transmit direction and one DS0 channel in the receive direction at the same time. [Table 8-29](#) shows the registers related to the control of transmit and receive DS0.

Table 8-29. Registers Related to DS0 Monitoring

REGISTER	FRAMER ADDRESSES	FUNCTION
Transmit DS0 Channel Monitor Select (TDS0SEL)	189h	Transmit channel to be monitored.
Transmit DS0 Monitor Register (TDS0M)	1BBh	Monitored data.
Receive Channel Monitor Select Register (RDS0SEL)	012h	Receive channel to be monitored.
Receive DS0 Monitor Register (RDS0M)	060h	Monitored data.

Note: The addresses shown are for Framer 1. Addresses for Framers 2 to 4 can be calculated using the following: Framer n = (Framer 1 address + $(n - 1) \times 200h$); where $n = 2$ to 4 for Framers 2 to 4.

In the transmit direction, the user determines which channel is to be monitored by properly setting the TCM[4:0] bits in the [TDS0SEL](#) register. In the receive direction, the RCM[4:0] bits in the [RDS0SEL](#) register need to be properly set. The DS0 channel pointed to by the TCM[4:0] bits appear in the Transmit DS0 Monitor register ([TDS0M](#)) and the DS0 channel pointed to by the RCM[4:0] bits appear in the Receive DS0 Monitor register ([RDS0M](#)). The TCM[4:0] and RCM[4:0] bits should be programmed with the decimal decode of the appropriate T1 or E1 channel. T1 channels 1 to 24 map to register values 0 to 23. E1 channels 1 to 32 map to register values 0 to 31. For example, if DS0 channel 6 in the transmit direction and DS0 channel 15 in the receive direction needed to be monitored, then the following values would be programmed into [TDS0SEL](#) and [RDS0SEL](#):

TCM4 = 0	RCM4 = 0
TCM3 = 0	RCM3 = 1
TCM2 = 1	RCM2 = 1
TCM1 = 0	RCM1 = 1
TCM0 = 1	RCM0 = 0

8.9.11 Transmit Per-Channel Idle Code Insertion

Channel data can be replaced by an idle code on a per-channel basis in the transmit and receive directions.

The Transmit Idle Code Definition registers ([TIDR1:TIDR32](#)) are provided to set the 8-bit idle code for each channel. The Transmit Channel Idle Code Enable registers ([TCICE1:TCICE4](#)) are used to enable idle code replacement on a per-channel basis.

8.9.12 Receive Per-Channel Idle Code Insertion

Channel data can be replaced by an idle code on a per-channel basis in the transmit and receive directions. The Receive Idle Code Definition registers ([RIDR1:RIDR32](#)) are provided to set the 8-bit idle code for each channel. The Receive Channel Idle Code Enable registers ([RCICE1:RCICE4](#)) are used to enable idle code replacement on a per-channel basis.

8.9.13 Per-Channel Loopback

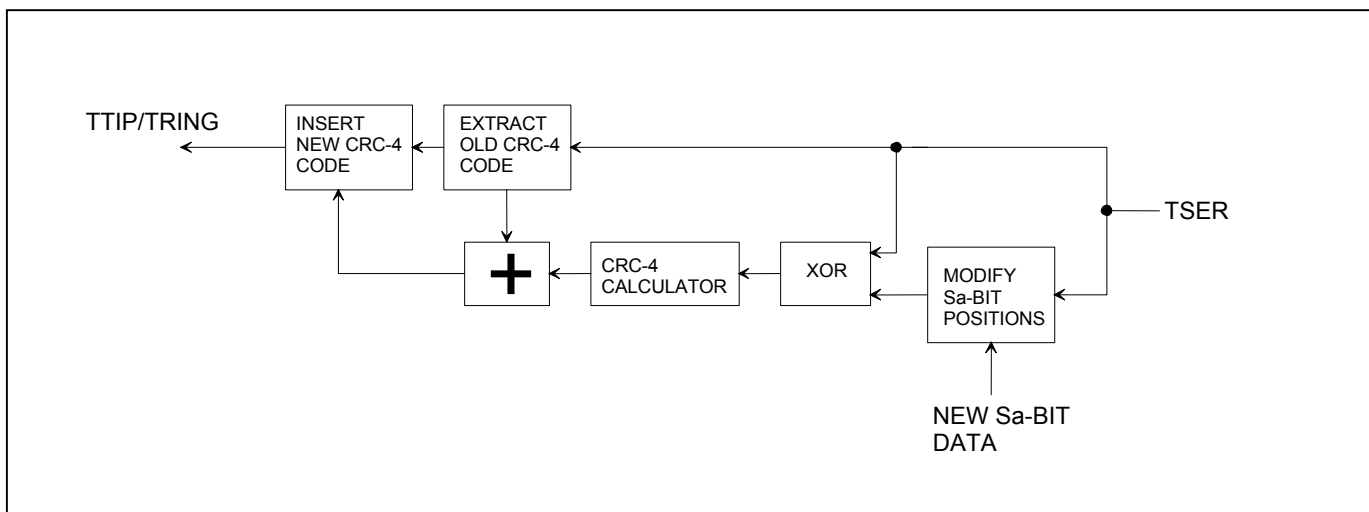
The Per-Channel Loopback Enable registers ([PCL1:PCL4](#)) determine which channels (if any) from the backplane should be replaced with the data from the receive side, i.e., off the T1 or E1 line. If this loopback is enabled, the transmit and receive clocks and frame syncs must be synchronized. One method to accomplish this would be to tie RCLK to TCLK and RFSYNC to TSYNC. There are no restrictions on which channels can be looped back or on how many channels can be looped back.

Each of the bit positions in the Per-Channel Loopback Enable registers ([PCL1:PCL4](#)) represents a DS0 channel in the outgoing frame. When these bits are set to 1, data from the corresponding receive channel replaces the data on [TSER](#) for that channel.

8.9.14 E1 G.706 Intermediate CRC-4 Updating (E1 Mode Only)

The DS26524 can implement the G.706 CRC-4 recalculation at intermediate path points. When this mode is enabled, the data stream presented at TSER will already have the FAS/NFAS, CRC multiframe alignment word, and CRC-4 checksum in time slot 0. The user can modify the Sa-bit positions and this change in data content will be used to modify the CRC-4 checksum. This modification, however, does not corrupt any error information the original CRC-4 checksum may contain. In this mode of operation, TSYNC must be configured to multiframe mode. The data at TSER must be aligned to the TSYNC signal. If TSYNC is an input, the user must assert TSYNC aligned at the beginning of the multiframe relative to TSER. If TSYNC is an output, the user must multiframe align the data presented to TSER. This mode is enabled with the [TCR3.0](#) control bit (CRC4R). Note that the E1 transmitter must already be enabled for CRC insertion with the [TCR1.0](#) control bit (TCRC4).

Figure 8-8. CRC-4 Recalculate Method



8.9.15 T1 Programmable In-Band Loop Code Generator

The DS26524 can generate and detect a repeating bit pattern from one to eight bits or 16 bits in length. **This function is available only in T1 mode.**

Table 8-30. Registers Related to T1 In-Band Loop Code Generator

REGISTER	FRAMER ADDRESSES	FUNCTION
Transmit Code Definition Register 1 (T1TCD1)	1ACh	Pattern to be sent for loop code.
Transmit Code Definition Register 2 (T1TCD2)	1ADh	Length of the pattern to be sent.
Transmit Control Register 3 (TCR3)	183h	TLOOP bit for control of number of patterns being sent.
Transmit Control Register 4 (TCR4)	186h	Length of the code being sent.

Note: The addresses shown are for Framer 1. Addresses for Framers 2 to 4 can be calculated using the following: Framer $n = (\text{Framer 1 address} + (n - 1) \times 200h)$; where $n = 2$ to 4 for Framers 2 to 4.

To transmit a pattern, the user loads the pattern to be sent into the Transmit Code Definition registers ([T1TCD1](#) and [T1TCD2](#)) and selects the proper length of the pattern by setting the TC1 and TC0 bits in Transmit Control Register 4 ([TCR4](#)). When generating a 1-, 2-, 4-, 8-, or 16-bit pattern, both [T1TCD1](#) and [T1TCD2](#) must be filled with the proper code. Generation of a 3-, 5-, 6-, and 7-bit pattern only requires [T1TCD1](#) to be filled. Once this is accomplished, the pattern is transmitted as long as the TLOOP control bit ([TCR3.0](#)) is enabled. Normally (unless the transmit formatter is programmed to not insert the F-bit position) the framer overwrites the repeating pattern once every 193 bits to allow the F-bit position to be sent.

As an example, to transmit the standard loop-up code for Channel Service Units (CSUs), which is a repeating pattern of ...10000100001..., set TCD1 = 80h, TC0 = 0, TC1 = 0, and TCR3.0 = 1.

8.9.16 T1 Programmable In-Band Loop Code Detection

The DS26524 can generate and detect a repeating bit pattern from one to eight bits or 16 bits in length. **This function is available only in T1 mode.**

Table 8-31. Registers Related to T1 In-Band Loop Code Detection

REGISTER	FRAMER ADDRESSES	FUNCTION
Receive In-Band Code Control Register (T1RIBCC)	082h	Used for selecting length of receive in-band loop code register.
Receive Up Code Definition Register 1 (T1RUPCD1)	0ACh	Receive up code definition register 1.
Receive Up Code Definition Register 2 (T1RUPCD2)	0ADh	Receive up code definition register 2.
Receive Down Code Definition Register 1 (T1RDNCD1)	0AEh	Receive down code definition register 1.
Receive Down Code Definition Register 2 (T1RDNCD2)	0AFh	Receive up code definition register 2.
Receive Spare Code Register 1 (T1RSCD1)	09Ch	Receive spare code register 1.
Receive Spare Code Register 2 (T1RSCD2)	09Dh	Receive spare code register 2.
Receive Real-Time Status Register 3 (RRTS3)	0B2h	Real-time loop code detect.
Receive Latched Status Register 3 (RLS3)	092h	Latched loop code detect bits.
Receive Interrupt Mask Register 3 (RIM3)	0A2h	Mask for latched loop code detect bits.

Note: The addresses shown are for Framer 1. Addresses for Framers 2 to 4 can be calculated using the following: Framer $n = (\text{Framer 1 address} + (n - 1) \times 200h)$; where $n = 2$ to 4 for Framers 2 to 4.

The framer has three programmable pattern detectors. Typically, two of the detectors are used for “loop-up” and “loop-down” code detection. The user programs the codes to be detected in the Receive Up Code Definition registers ([T1RUPCD1](#) and [T1RUPCD2](#)) and the Receive Down Code Definition registers ([T1RDNCD1](#) and [T1RDNCD2](#)). The length of each pattern is selected via the Receive In-Band Code Control register ([T1RIBCC](#)). There is a third detector (Spare) and it is defined and controlled via the [T1RSCD1/T1RSCD2](#) and [T1RSCC](#) registers. When detecting a 16-bit pattern, both receive code definition registers are used together to form a 16-bit register. For 8-bit patterns, both receive code definition registers are filled with the same value. Detection of a 1-, 2-, 3-, 4-, 5-, 6-, and 7-bit pattern only requires the first receive code definition register to be filled. The framer detects repeating pattern codes in both framed and unframed circumstances with bit-error rates as high as $10E-2$. The detectors can handle both F-bit inserted and F-bit overwrite patterns. Writing the least significant byte of the receive code definition register resets the integration period for that detector. The code detector has a nominal integration period of 48ms. Thus, after about 48ms of receiving a valid code, the proper status bit (LUP, LDN, and LSP) is set to 1. Note that real-time status bits, as well as latched set and clear bits, are available for LUP, LDN, and LSP ([RRTS3](#) and [RLS3](#)). Normally codes are sent for a period of 5 seconds. It is recommended that the software poll the framer every 50ms to 100ms until 5 seconds has elapsed to ensure that the code is continuously present.

8.9.17 Framer Payload Loopbacks

The framer, payload, and remote loopbacks are controlled by Receive Control Register 3 ([RCR3](#)).

Table 8-32. Registers Related to Framer Payload Loopbacks

RECEIVE CONTROL REGISTER 3 (RCR3)	FRAMER ADDRESSES	FUNCTION
Framer Loopback	083h	Transmit data output from the framer is looped back to the receiver.
Payload Loopback	083h	The 192-bit payload data is looped back to the transmitter.
Remote Loopback	083h	Data recovered by the receiver is looped back to the transmitter.

Note: The addresses shown are for Framer 1. Addresses for Framers 2 to 4 can be calculated using the following: Framer n = (Framer 1 address + $(n - 1) \times 200h$); where $n = 2$ to 4 for Framers 2 to 4.

8.10 HDLC Controllers

8.10.1 Receive HDLC Controller

The DS26524 has an enhanced HDLC controller that can be mapped into a single time slot, or Sa4 to Sa8 bits (E1 mode), or the FDL (T1 mode). The HDLC controller has a 64-byte FIFO buffer in both the transmit and receive paths. The user can select any specific bits within the time slot(s) to assign to the HDLC controller, as well as specific Sa bits (E1 mode).

The HDLC controller performs all the necessary overhead for generating and receiving performance report messages (PRMs) as described in ANSI T1.403 and the messages as described in AT&T TR54016. The HDLC controller automatically generates and detects flags, generates and checks the CRC check sum, generates and detects abort sequences, stuffs and destuffs zeros, and byte aligns to the data stream. The 64-byte buffers in the HDLC controller are large enough to allow a full PRM to be received or transmitted without host intervention.

[Table 8-33](#) shows the registers related to the HDLC.

Table 8-33. Registers Related to the HDLC

REGISTER	FRAMER ADDRESSES	FUNCTION
Receive HDLC Control Register (RHC)	010h	Mapping of the HDLC to DS0 or FDL.
Receive HDLC Bit Suppress Register (RHBSE)	011h	Receive HDLC bit suppression register.
Receive HDLC FIFO Control Register (RHFC)	087h	Determines the length of the receive HDLC FIFO.
Receive HDLC Packet Bytes Available Register (RHPBA)	0B5h	Tells the user how many bytes are available in the receive HDLC FIFO.
Receive HDLC FIFO Register (RHF)	0B6h	The actual FIFO data.
Receive Real-Time Status Register 5 (RRTS5)	0B4h	Indicates the FIFO status.
Receive Latched Status Register 5 (RLS5)	094h	Latched status.
Receive Interrupt Mask Register 5 (RIM5)	0A4h	Interrupt mask for interrupt generation for the latched status.
Transmit HDLC Control Register 1 (THC1)	110h	Miscellaneous transmit HDLC control.
Transmit HDLC Bit Suppress Register (THBSE)	111h	Transmit HDLC bit suppress for bits not to be used.
Transmit HDLC Control Register 2 (THC2)	113h	HDLC to DS0 channel selection and other control.
Transmit HDLC FIFO Control Register (THFC)	187h	Used to control the transmit HDLC FIFO.
Transmit Real-Time Status Register 2 (TRTS2)	1B1h	Indicates the real-time status of the transmit HDLC FIFO.
Transmit HDLC Latched Status Register 2 (TLS2)	191h	Indicates the FIFO status.
Transmit Interrupt Mask Register 2 (HDLC) Register (TIM2)	1A1h	Interrupt mask for the latched status.
Transmit HDLC FIFO Buffer Available Register (TFBA)	1B3h	Indicates the number of bytes that can be written into the transmit FIFO.
Transmit HDLC FIFO Register (THF)	1B4h	Transmit HDLC FIFO.

Note: The addresses shown are for Framer 1. Addresses for Framers 2 to 4 can be calculated using the following: Framer n = (Framer 1 address + $(n - 1) \times 200h$); where $n = 2$ to 4 for Framers 2 to 4.

8.10.1.1 HDLC FIFO Control

Control of the transmit and receive FIFOs is accomplished via the Receive HDLC FIFO Control ([RHFC](#)) and Transmit HDLC FIFO Control ([THFC](#)) registers. The FIFO control registers set the watermarks for the FIFO.

When the receive FIFO fills above the high watermark, the RHWM bit ([RRTS5.1](#)) is set. RHWM and THRM are real-time bits and remain set as long as the FIFO's write pointer is above the watermark. When the transmit FIFO empties below the low watermark, the TLWM bit in the [TRTS2](#) register is set. TLWM is a real-time bit and remains set as long as the transmit FIFO's write pointer is below the watermark. If enabled, this condition can also cause an interrupt via the INTB pin.

If the receive HDLC FIFO does overrun, the current packet being processed is dropped. The receive FIFO is emptied. The packet status bit in [RRTS5](#) and [RLS5.5](#) (ROVR) indicate an overrun.

8.10.1.2 Receive HDLC Packet Bytes Available

The lower 7 bits of the Receive HDLC Packet Bytes Available register ([RHPBA](#)) indicates the number of bytes (0 to 64) that can be read from the receive FIFO. The value indicated by this register informs the host as to how many bytes can be read from the receive FIFO without going past the end of a message. This value refers to one of four possibilities: the first part of a packet, the continuation of a packet, the last part of a packet, or a complete packet. After reading the number of bytes indicated by this register, the host then checks the HDLC status registers for detailed message status.

If the value in the [RHPBA](#) register refers to the beginning portion of a message or continuation of a message, then the MSB of the RHPBA register returns a value of 1. This indicates that the host can safely read the number of bytes returned by the lower 7 bits of the RHPBA register, but there is no need to check the information register since the packet has not yet terminated (successfully or otherwise).

8.10.1.3 HDLC Status and Information

[RRTS5](#), [RLS5](#), and [TLS2](#) provide status information for the HDLC controller. When a particular event has occurred (or is occurring), the appropriate bit in one of these registers is set to 1. Some of the bits in these registers are latched and some are real-time bits that are not latched. This section contains register descriptions that list which bits are latched and which are real-time. With the latched bits, when an event occurs and a bit is set to 1, it remains set until the user reads and clears that bit. The bit is cleared when a 1 is written to the bit, and it will not be set again until the event has occurred again. The real-time bits report the current instantaneous conditions that are occurring and the history of these bits is not latched.

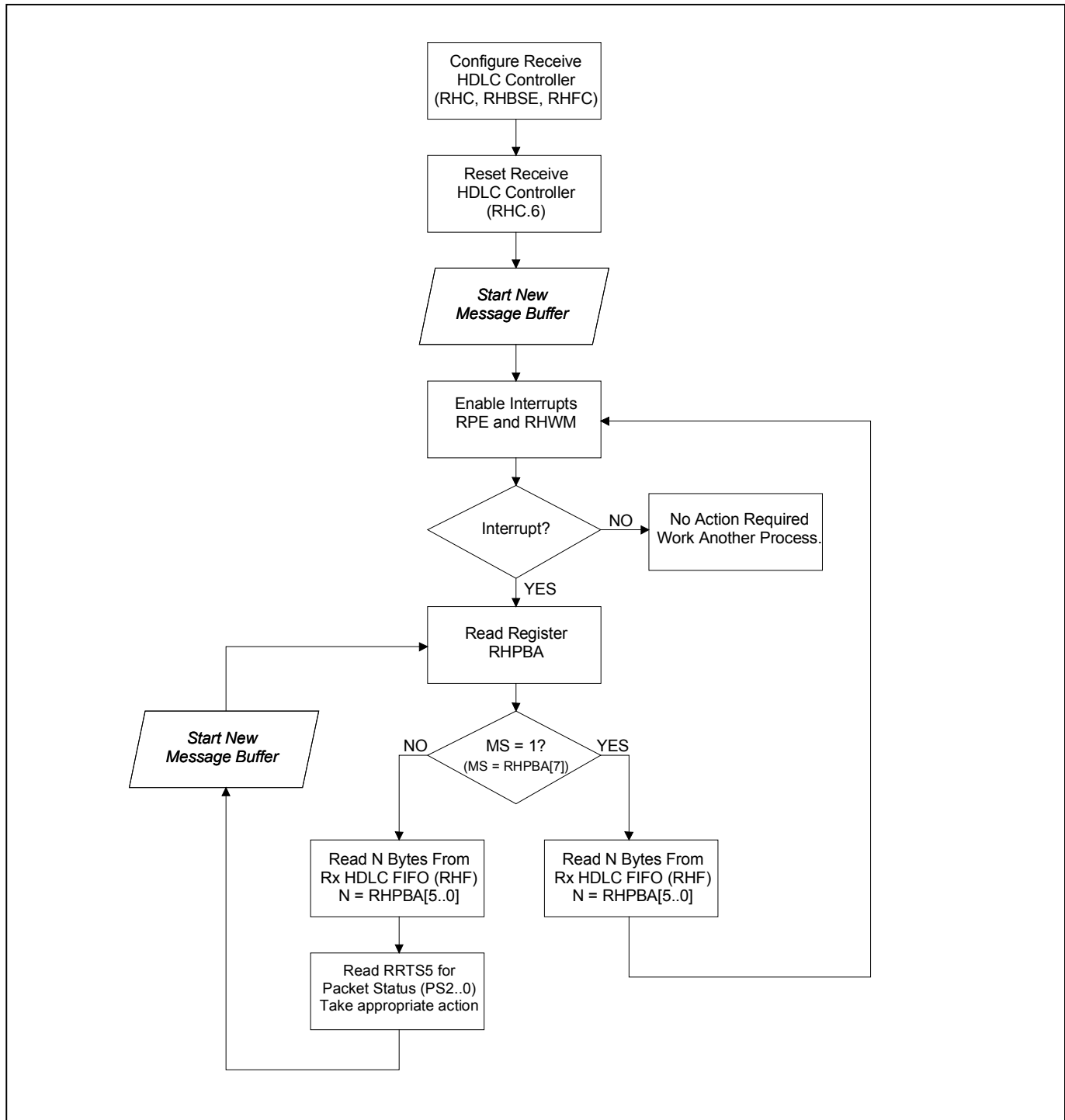
Like the other latched status registers, the user follows a read of the status bit with a write. The byte written to the register informs the device which of the latched bits the user wishes to clear (the real-time bits are not affected by writing to the status register). The user writes a byte to one of these registers, with a 1 in the bit positions he or she wishes to clear and a 0 in the bit positions he or she does not wish to clear.

The HDLC status registers [RLS5](#) and [TLS2](#) have the ability to initiate a hardware interrupt via the $\overline{\text{INTB}}$ output signal. Each of the events in this register can be either masked or unmasked from the interrupt pin via the HDLC interrupt mask registers [RIM5](#) and [TIM2](#). Interrupts force the $\overline{\text{INTB}}$ signal low when the event occurs. The $\overline{\text{INTB}}$ pin is allowed to return high (if no other interrupts are present) when the user reads the event bit that caused the interrupt to occur.

8.10.1.4 HDLC Receive Example

The HDLC status registers in the DS26524 allow for flexible software interface to meet the user's preferences. When receiving HDLC messages, the host can choose to be interrupt driven, or to poll to desired status registers, or a combination of polling and interrupt processes can be used. An example routine for using the DS26524 HDLC receiver is given in [Figure 8-9](#).

Figure 8-9. Receive HDLC Example



8.10.2 Transmit HDLC Controller

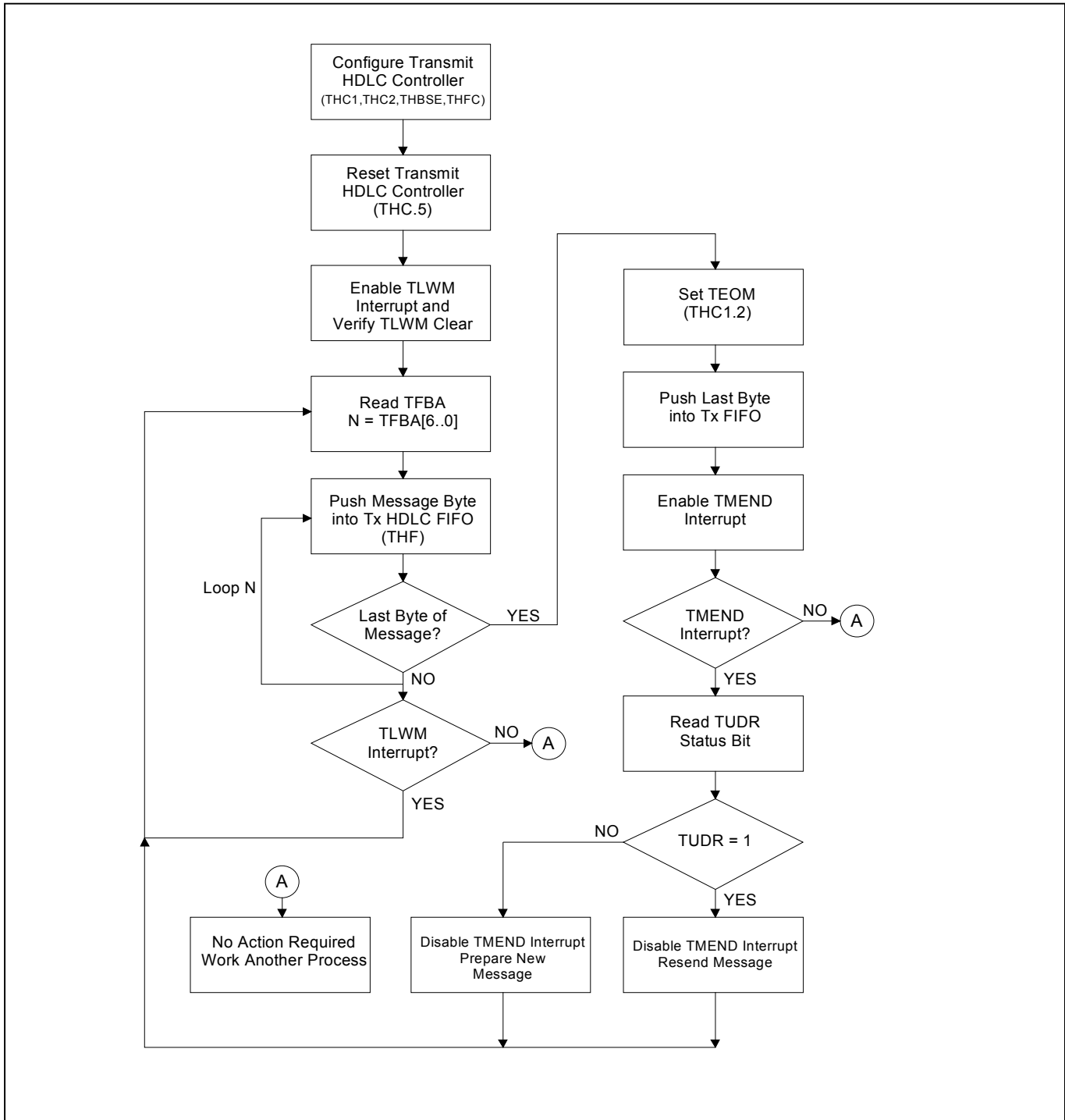
8.10.2.1 FIFO Information

The Transmit HDLC FIFO Buffer Available register ([TFBA](#)) indicates the number of bytes that can be written into the transmit FIFO. The count from this register informs the host as to how many bytes can be written into the transmit FIFO without overflowing the buffer. This is a real-time register. The count shall remain valid and stable during the read cycle.

8.10.2.2 HDLC Transmit Example

The HDLC status registers in the DS26524 allow for flexible software interface to meet the user's preferences. When transmitting HDLC messages, the host can choose to be interrupt driven, or to poll to desired status registers, or a combination of polling and interrupt processes can be used. An example routine for using the DS26524 HDLC receiver is given in [Figure 8-10](#).

Figure 8-10. HDLC Message Transmit Example



8.11 Line Interface Units (LIUs)

The DS26524 has four identical LIU transmit and receive front-ends for the four framers. Each LIU contains three sections: the transmitter, which waveshapes and drives the network line; the receiver, which handles clock and data recovery; and the jitter attenuator. The DS26524 LIUs can switch between T1 or E1 networks without changing any external components on either the transmit or receive side. [Figure 8-11](#) shows a recommended circuit for software-selected termination with protection. In this configuration, the device can connect to 100 Ω T1 twisted pair, 110 Ω J1 twisted pair, 75 Ω or 120 Ω E1 twisted pair without additional component changes. The signals between the framer and LIU are not accessible by the user, thus the framer and LIU cannot be separated. The transmitters have fast high-impedance capability and can be individually powered down.

The DS26524's transmit waveforms meet the corresponding G.703 and T1.102 specifications. Internal software-selectable transmit termination is provided for 100 Ω T1 twisted pair, 110 Ω J1 twisted pair, 120 Ω E1 twisted pair, and 75 Ω E1 coaxial applications. The receiver can connect to 100 Ω T1 twisted pair, 110 Ω J1 twisted pair, 120 Ω E1 twisted pair, and 75 Ω E1 coaxial. The receive LIU can function with a receive signal attenuation of up to 36dB for T1 mode and 43dB for E1 mode. The receiver sensitivity is programmable from 12dB to 43dB of cable loss. Also, a monitor gain setting can be enabled to provide 14dB, 20dB, 26dB, and 32dB of resistive gain.

Figure 8-11. Network Connection for Software-Selected Termination—Longitudinal Protection

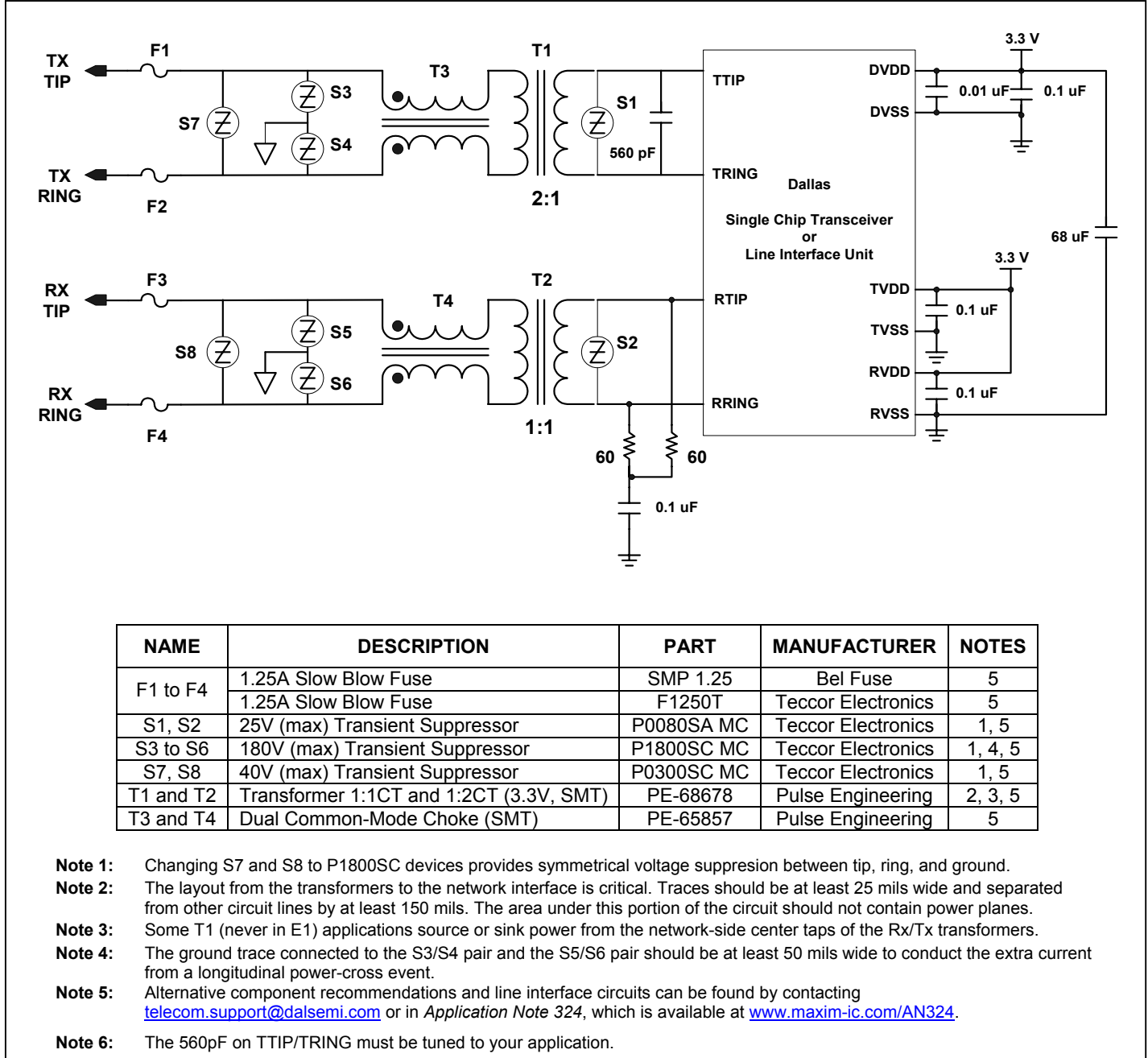


Table 8-34. Recommended Supply Decoupling

SUPPLY PINS	DECOUPLING CAPACITANCE	NOTES
DVDD/DVSS	$0.01\mu\text{F} + 0.1\mu\text{F} + 1\mu\text{F} + 10\mu\text{F}$	—
DVDDIO/DVSSIO	$0.01\mu\text{F} + 0.1\mu\text{F} + 1\mu\text{F} + 10\mu\text{F}$	—
ATVDD/ATVSS	$0.1\mu\text{F} (\text{x}8) + 1\mu\text{F} (\text{x}4) + 10\mu\text{F} (\text{x}2)$	It is recommended to use one $0.1\mu\text{F}$ capacitor for each ATVDD/ATVSS pair (8 total), one $1\mu\text{F}$ for every two ATVDD/ATVSS pairs (4 total), and two $10\mu\text{F}$ capacitors for the analog transmit supply pins. These capacitors should be located as close to the intended power pins as possible.
ARVDD/ARVSS	$0.1\mu\text{F} (\text{x}8) + 1\mu\text{F} (\text{x}4) + 10\mu\text{F} (\text{x}2)$	It is recommended to use one $0.1\mu\text{F}$ capacitor for each ARVDD/ARVSS pair (8 total), one $1\mu\text{F}$ for every two ARVDD/ARVSS pairs (4 total), and two $10\mu\text{F}$ capacitors for the analog receive supply pins. These capacitors should be located as close to the intended power pins as possible.
ACVDD/ACVSS	$0.1\mu\text{F} + 1\mu\text{F} + 10\mu\text{F}$	—

8.11.1 LIU Operation

The analog AMI/HDB3 waveforms off of the E1 lines or the AMI/B8ZS waveform off of the T1 lines are transformer coupled into the RTIP and RRING pins of the DS26524. The user has the option to use internal termination, software selectable for 75Ω/100Ω/110Ω/120Ω applications, or external termination. The LIU recovers clock and data from the analog signal and passes it through the jitter attenuation mux. The DS26524 contains an active filter that reconstructs the analog received signal for the nonlinear losses that occur in transmission. The receive circuitry also is configurable for various monitor applications. The device has a usable receive sensitivity of 0dB to -43dB for E1 and 0dB to -36dB for T1, which allows the device to operate on 0.63mm (22AWG) cables up to 2.5km (E1) and 6k feet (T1) in length. Data input to the transmit side of the LIU is sent via the jitter attenuation mux to the waveshaping circuitry and line driver. The DS26524 drives the E1 or T1 line from the TTIP and TRING pins via a coupling transformer. The line driver can handle both CEPT 30/ISDN-PRI lines for E1 and long-haul (CSU) or short-haul (DSX-1) lines for T1. The registers that control the LIU operation are shown in [Table 8-35](#).

Table 8-35. Registers Related to Control of DS26524 LIU

REGISTER	FRAMER ADDRESSES	FUNCTION
Global Transceiver Control Register 2 (GTCR2)	0F2h	Global transceiver control.
Global Transceiver Clock Control Register (GTCCR)	0F3h	MPS selections, backplane clock selections
Global LIU Software Reset Register (GLSRR)	0F5h	Software reset control for the LIU.
Global LIU Interrupt Status Register (GLISR)	0FBh	Interrupt status bit for each of the 4 LIUs.
Global LIU Interrupt Mask Register (GLIMR)	0FEh	Interrupt mask register for the LIU.
LIU Transmit Receive Control Register (LTRCR)	1000h	T1/J1/E1 selection, output tri-state, loss criteria.
LIU Transmit Impedance and Pulse Shape Selection Register (LTITSR)	1001h	Transmit pulse shape and impedance selection.
LIU Maintenance Control Register (LMCR)	1002h	Transmit maintenance and jitter attenuation control register.
LIU Real Status Register (LRSR)	1003h	LIU real-time status register.
LIU Status Interrupt Mask Register (LSIMR)	1004h	LIU mask registers based on latched status bits.
LIU Latched Status Register (LLSR)	1005h	LIU latched status bits related to loss, open circuit, etc.
LIU Receive Signal Level Register (LRSL)	1006h	LIU receive signal level indicator.
LIU Receive Impedance and Sensitivity Monitor Register (LRISMR)	1007h	LIU impedance match and sensitivity monitor.

Note: The addresses shown are for Framer 1. Addresses for Framers 2 to 4 can be calculated using the following framer: Framer $n = (\text{Framer 1 address} + (n - 1) \times 200h)$; where $n = 2$ to 4 for Framers 2 to 4.

8.11.2 Transmitter

NRZ data arrives from the framer transmitter; the data is encoded with HDB3 or B8ZS or AMI. The encoded data passes through a jitter attenuator if it is enabled for the transmit path. A digital sequencer and DAC are used to generate transmit waveforms compliant with T1.102 and G.703 pulse templates.

A line driver is used to drive an internal matched impedance circuit for provision of 75Ω, 100Ω, 110Ω, and 120Ω terminations. The transmitter couples to the E1 or T1 transmit twisted pair (or coaxial cable in some E1 applications) via a 1:2 step-up transformer. For the device to create the proper waveforms, the transformer used must meet the specifications listed in [Table 8-37](#). The transmitter requires a transmit clock of 2.048MHz for E1 or 1.544MHz for T1/J1 operation.

The DS26524 drivers have a short-circuit and open-circuit detection driver-fail monitor. The TXENABLE pin can high impedance the transmitter outputs for protection switching. The individual transmitters can also be placed in high impedance through register settings. The DS26524 also has functionality for powering down the transmitters individually. The relevant telecommunications specification compliance is shown in [Table 8-36](#).

Table 8-36. Telecommunications Specification Compliance for DS26524 Transmitters

TRANSMITTER FUNCTION	TELECOMMUNICATIONS COMPLIANCE
T1 Telecom Pulse Template Compliance	ANSI T1.403
T1 Telecom Pulse Template Compliance	ANSI T1.102
Transmit Electrical Characteristics for E1 Transmission and Return Loss Compliance	ITU-T G.703

Table 8-37. Transformer Specifications

SPECIFICATION		RECOMMENDED VALUE
Turns Ratio 3.3V Applications		1:1 (receive) and 1:2 (transmit) ±2%
Primary Inductance		600μH minimum
Leakage Inductance		1.0μH maximum
Intertwining Capacitance		40pF maximum
Transmit Transformer DC Resistance	Primary (Device Side)	1.0Ω maximum
	Secondary	2.0Ω maximum
Receive Transformer DC Resistance	Primary (Device Side)	1.2Ω maximum
	Secondary	1.2Ω maximum

8.11.2.1 Transmit-Line Pulse Shapes

The DS26524 transmitters can be selected individually to meet the pulse templates for E1 and T1/J1 modes. The T1/J1 pulse template is shown in [Figure 8-12](#). The E1 pulse template is shown in [Figure 8-13](#). The transmit pulse shape can be configured for each LIU on an individual basis. The LIU transmit impedance selection registers can be used to select an internal transmit terminating impedance of 100Ω for T1, 110Ω for J1 mode, 75Ω or 120Ω for E1 mode or no internal termination for E1 or T1 mode. The transmit pulse shape and terminating impedance is selected by [LTITSR](#) registers. The pulse shapes will be compliant to T1.102 and G.703. Pulse shapes are measured for compliance at the appropriate network interface (NI). For T1 long haul and E1, the pulse shape is measured at the far end. For T1 short haul, the pulse shape is measured at the near end.

Figure 8-12. T1/J1 Transmit Pulse Templates

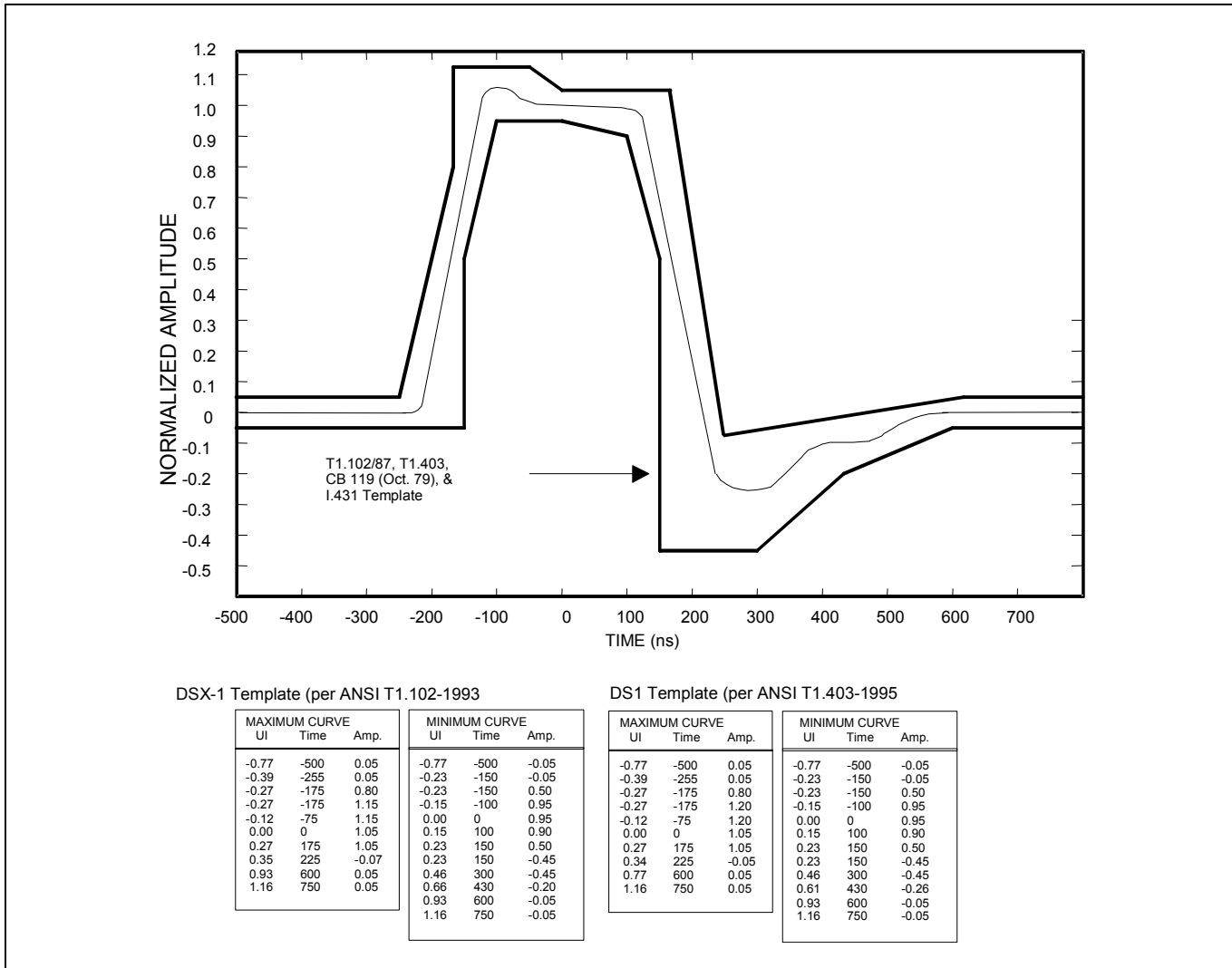
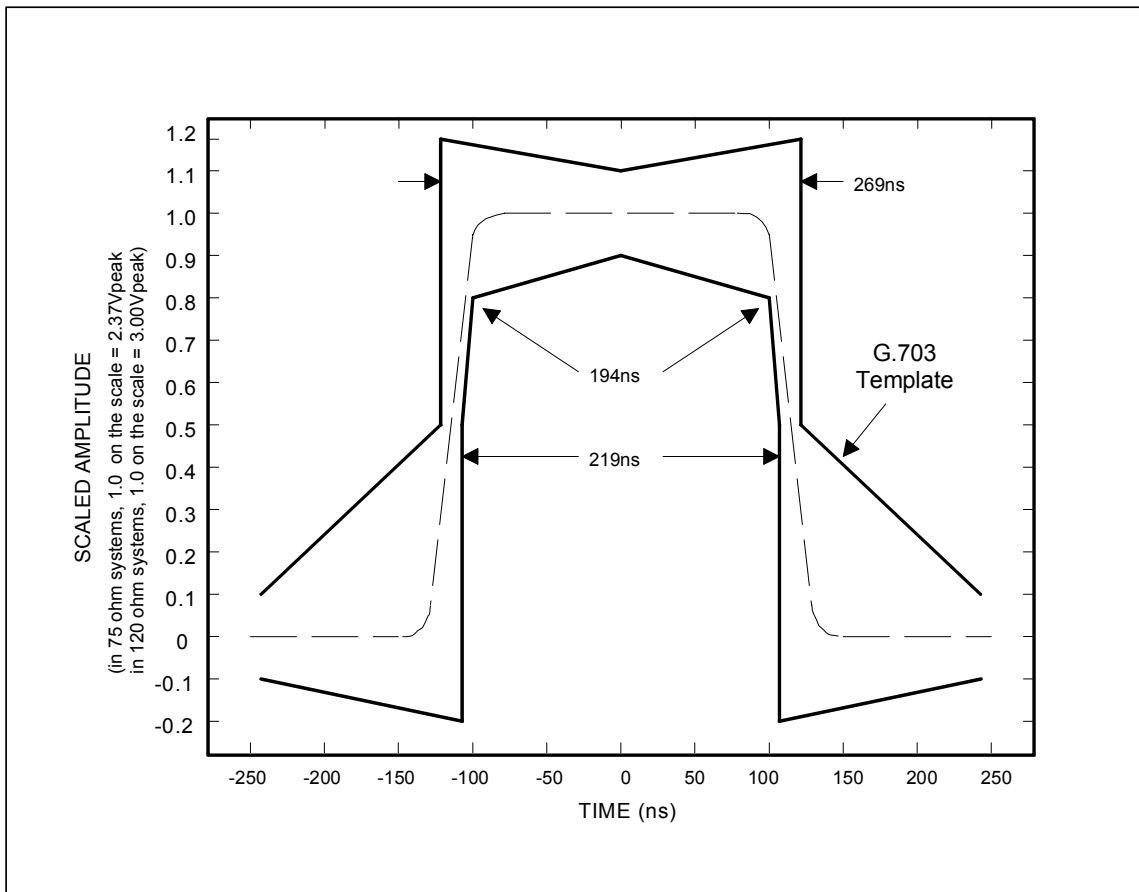


Figure 8-13. E1 Transmit Pulse Templates



8.11.2.2 Transmit Power-Down

The individual transmitters can be powered down by setting the TPDE bit in the LIU Maintenance Control register ([LMCR](#)). Note that powering down the transmit LIU results in a high-impedance state for the corresponding TTIP and TRING pins.

When transmit all ones (AIS) is invoked, continuous ones are transmitted using MCLK as the timing reference. Data input from the framer is ignored. AIS can be sent by setting a bit in the [LMCR](#). Transmit all ones will also be sent if the corresponding receiver goes into LOS state and the ATAIS bit is set in the [LMCR](#).

8.11.2.3 Transmit Short-Circuit Detector/Limiter

Each transmitter has an automatic short-circuit current limiter that activates when the load resistance is approximately 25Ω or less. SCS ([LRSR.2](#)) provides a real-time indication of when the current limiter is activated. The LIU Latched Status register ([LLSR](#)) provides latched versions of the information, which can be used to activate an interrupt when enabled via the [LSIMR](#) register.

8.11.2.4 Transmit Open-Circuit Detector

The DS26524 can also detect when the TTIP or TRING outputs are open circuited. OCS ([LRSR.1](#)) provides a real-time indication of when an open circuit is detected. Register [LLSR](#) provides latched versions of the information, which can be used to activate an interrupt when enabled via the [LSIMR](#) register. The open-circuit detect feature is not available in T1 CSU operating modes (LBO5, LBO6, and LBO7).

8.11.3 Receiver

The DS26524 contains four identical receivers. The four receivers are designed to be fully software-selectable for E1, T1, and J1 without the need to change any external resistors. The device couples to the receive E1 or T1 twisted pair (or coaxial cable in 75 Ω E1 applications) via a 1:1 or 2:1 transformer. See [Table 8-37](#) for transformer details. Receive termination and sensitivity are user configurable. Receive termination is configurable for 75 Ω , 100 Ω , 110 Ω , or 120 Ω termination by setting the appropriate RIMPM[1:0] bits ([LRISMR](#)). When using the internal termination feature, the resistors labeled Rr in [Figure 8-11](#) should be 60 Ω each. If external termination is required, the resistors need to be 37.5 Ω , 50 Ω , or 60 Ω each depending on the line impedance. Receive sensitivity is configurable by setting the appropriate RSMS[1:0] bits ([LRISMR](#)).

The DS26524 uses a digital clock recovery system. The resultant E1, T1, or J1 clock derived from MCLK is multiplied by 16 via an internal PLL and fed to the clock recovery system. The clock recovery system uses the clock from the PLL circuit to form a 16 times oversampler, which is used to recover the clock and data. This oversampling technique offers outstanding performance to meet jitter tolerance specifications shown in [Figure 8-15](#).

Normally, the clock that is output at the RCLK pin is the recovered clock from the E1 AMI/HDB3 or T1 AMI/B8ZS waveform presented at the RTIP and RRING inputs. If the jitter attenuator ([LTRCR](#)) is placed in the receive path (as is the case in most applications), the jitter attenuator restores the RCLK to an approximate 50% duty cycle. If the jitter attenuator is either placed in the transmit path or is disabled, the RCLK output can exhibit slightly shorter high cycles of the clock. This is due to the highly oversampled digital clock recovery circuitry. See [Table 12-2](#) for more details. When no signal is present at RTIP and RRING, a receive carrier loss (RCL) condition occurs and the RCLK is derived from the JACLK source.

8.11.3.1 Receive Level Indicator

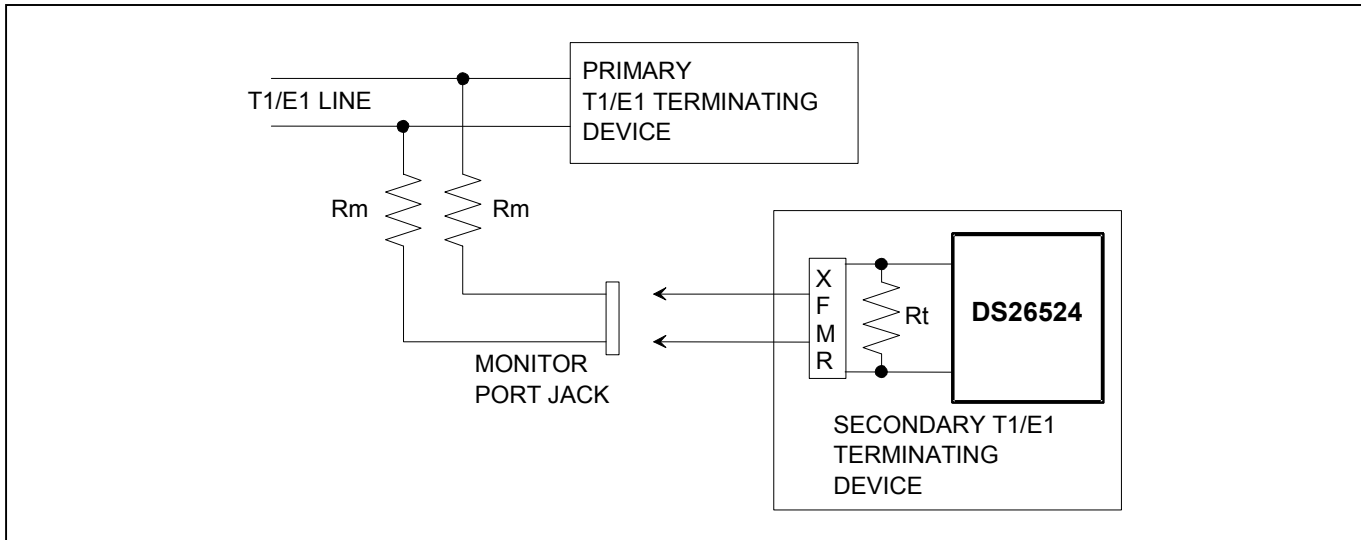
The DS26524 reports the signal strength at RTIP and RRING in approximately 2.5dB increments via RSL[3:0] located in the LIU Receive Signal Level register ([LRSL](#)). This feature is helpful when trouble shooting line performance problems.

8.11.3.2 Receive G.703 Section 10 Synchronization Signal

The DS26524 can receive a 2.048MHz square-wave synchronization clock as specified in Section 10 of ITU-T G.703. To use this mode, set the receive G.703 clock-enable bit RG703 ([LRISMR.7](#)) found in the LIU Receive Impedance and Sensitivity Monitor register ([LRISMR](#)).

8.11.3.3 Receiver Monitor Mode

The receive equalizer is equipped with a monitor mode function that is used to overcome the signal attenuation caused by the resistive bridge used in monitoring applications. This function allows for a resistive gain of up to 32dB, along with cable attenuation of 12dB to 30dB as shown in the LIU Receive Impedance and Sensitivity Monitor register ([LRISMR](#)).

Figure 8-14. Typical Monitor Application**8.11.3.4 Loss of Signal (LOS)**

The DS26524 uses both the digital and analog loss-detection method in compliance with the latest ANSI T1.231 for T1/J1 and ITU-T G.775, or ETS 300 233 for E1 mode of operation.

Loss of signal (LOS) is detected if the receiver level falls below a threshold analog voltage for certain duration. Alternatively, this can be termed as having received “0s” for a certain duration. The signal level and timing duration are defined in accordance with the ANSI T1.231, ITU-T G.775, or ETS 300 233 specifications.

For short-haul mode, the loss-detection thresholds are based on cable loss of 12dB to 18dB for both T1/J1 and E1 modes. The loss thresholds are selectable based on [Table 9-19](#). For long-haul mode, the LOS detection threshold is based on cable loss of 30dB to 38dB for T1/J1 and 30dB to 45dB for E1 mode. Note there is no explicit bit called short-haul mode selection. Loss declaration level is set at 3dB lower than the maximum sensitivity setting programmed in [Table 9-19](#).

The loss state is exited when the receiver detects a certain ones density at the maximum sensitivity level or higher, which is 3dB higher than the loss-detection level. The loss-detection signal level and loss-reset signal level are defined with hysteresis to prevent the receiver from bouncing between “LOS” and “no LOS” states. [Table 8-38](#) outlines the specifications governing the loss function.

Table 8-38. ANSI T1.231, ITU-T G.775, and ETS 300 233 Loss Criteria Specifications

CRITERIA	STANDARD		
	ANSI T1.231	ITU-T G.775	ETS 300 233
Loss Detection	No pulses are detected for 175 \pm 75 bits.	No pulses are detected for duration of 10 to 255-bit periods.	No pulses are detected for a duration of 2048-bit periods or 1ms.
Loss Reset	Loss is terminated if a duration of 12.5% ones are detected over duration of 175 \pm 75 bits. Loss is not terminated if 8 consecutive zeros are found if B8ZS encoding is used. If B8ZS is not used, loss is not terminated if 100 consecutive pulses are zero.	The incoming signal has transitions for duration of 10 to 255-bit periods.	Loss reset criteria are not defined.

8.11.3.5 ANSI T1.231 for T1 and J1 Modes

For short-haul mode, loss is declared if the received signal level is 3dB lower from the programmed value (based on [Table 9-19](#)) for a duration of 192-bit periods. Hence, if the sensitivity is programmed to be 12dB, loss will be declared at 15dB. LOS is reset if the following criteria are met:

- 1) 24 or more ones are detected in 192-bit period with a programmed sensitivity level measured at RTIP and RRING.
- 2) During the 192 bits, fewer than 100 consecutive zeros are detected.

For long-haul mode, loss is detected if the received signal level is 3dB lower from the programmed value (based on [Table 9-19](#)) for a duration of 192-bit periods. Hence, if the sensitivity is programmed at 30dB, loss declaration level will be 33dB. LOS is reset if the following criteria are met:

- 1) 24 or more ones are detected in 192-bit period with a programmed sensitivity level measured at RTIP and RRING.
- 2) During the 192 bits, fewer than 100 consecutive zeros are detected.

8.11.3.6 ITU-T G.775 for E1 Modes

For short-haul mode, loss is declared if the received signal level is 3dB lower from the programmed value (based on [Table 9-19](#)) for a duration of 192-bit periods. Hence, if the sensitivity is programmed to be 12dB, loss will be declared at 15dB. LOS is reset if the receive signal level is greater than or equal to the programmed sensitivity level for a duration of 192-bit periods.

For long-haul mode, loss is detected if the received signal level is 3dB lower from the programmed value (based on [Table 9-19](#)) for a duration of 192-bit periods. Hence, if the sensitivity is programmed at 30dB, loss declaration level will be 33dB. LOS is reset if the receive signal level is greater than or equal to the programmed sensitivity level for a duration of 192-bit periods.

8.11.3.7 ETS 200 233 for E1 Modes

For short-haul mode, loss is declared if the received signal level is 3dB lower from the programmed value (based on [Table 9-19](#)) continuous duration of 2048-bit periods (1ms). LOS is reset if the receive signal level is greater than or equal to programmed sensitivity level for a duration of 192-bit periods.

For long-haul mode, loss is declared if the received signal level is 3dB lower from the programmed value (based on [Table 9-19](#)) continuous duration of 2048-bit periods (1ms). LOS is reset if the receive signal level is greater than or equal to the programmed sensitivity level for a duration of 192-bit periods.

8.11.4 Jitter Attenuator

The DS26524 contains a jitter attenuator for each LIU that can be set to a depth of 32 or 128 bits via the JADS ([LTRCR.4](#)) bit in the LIU Transmit Receive Control register ([LTRCR](#)).

The 128-bit mode is used in applications where large excursions of wander are expected. The 32-bit mode is used in delay-sensitive applications. The characteristics of the attenuation are shown in [Figure 8-15](#). The jitter attenuator can be placed in either the receive path, the transmit path, or disabled by appropriately setting the JAPS1 and JAPS0 bits in [LTRCR](#).

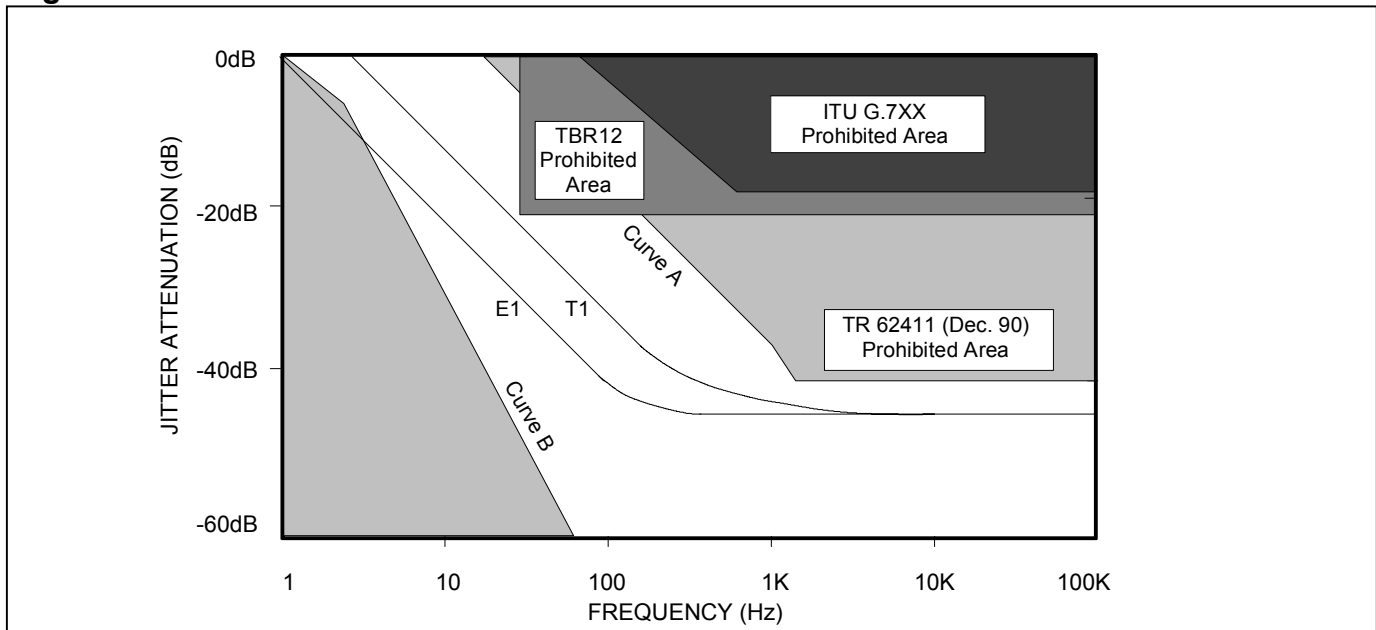
For the jitter attenuator to operate properly, a 2.048MHz, 1.544MHz, or a multiple of up to 8x clock must be applied at MCLK. See the Global Transceiver Clock Control register ([GTCCR](#)) for MCLK options. ITU-T specification G.703 requires an accuracy of ± 50 ppm for both T1/J1 and E1 applications. TR62411 and ANSI specs require an accuracy of ± 32 ppm for T1/J1 interfaces. Circuitry adjusts either the recovered clock from the clock/data recovery block or the clock applied at the TCLK pin to create a smooth jitter-free clock, which is used to clock data out of the jitter attenuator FIFO. It is acceptable to provide a gapped/bursty clock at the TCLK pin if the jitter attenuator is placed in the transmit side. If the incoming jitter exceeds either 120UI_{P-P} (buffer depth is 128 bits) or 28UI_{P-P} (buffer depth is 32 bits), the DS26524 sets the jitter attenuator limit trip set (JALTS) bit in the LIU Latched Status register ([LLSR.3](#)). In T1/J1 mode, the jitter attenuator corner frequency is 3.75Hz and in E1 mode it is 0.6Hz.

The DS26524 jitter attenuator is compliant with the following specifications shown in [Table 8-39](#).

Table 8-39. Jitter Attenuator Standards Compliance

STANDARD
ITU-T I.431, G.703, G.736, G.823
ETS 300 011, TBR 12/13
AT&T TR62411, TR43802
TR-TSY-009, TR-TSY-253, TR-TSY-499

Figure 8-15. Jitter Attenuation



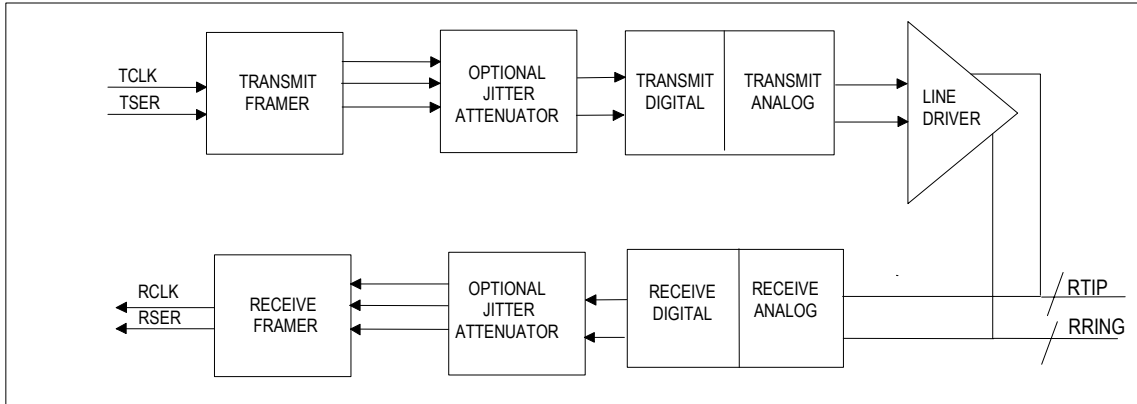
8.11.5 LIU Loopbacks

The DS26524 provides four LIU loopbacks for diagnostic purposes: analog loopback, local loopback, remote loopback, and dual loopback. In the loopback diagrams that follow, TSER, TCLK, RSER, and RCLK are inputs/outputs from the framer. Note that the framer input/output can be in IBO mode where a single TSER/RSER can be shared by up to eight framers.

8.11.5.1 Analog Loopback

The analog output of the transmitter TTIP and TRING is looped back to RTIP and RRING of the receiver. Data at RTIP and RRING is ignored in analog loopback. This is shown in [Figure 8-16](#).

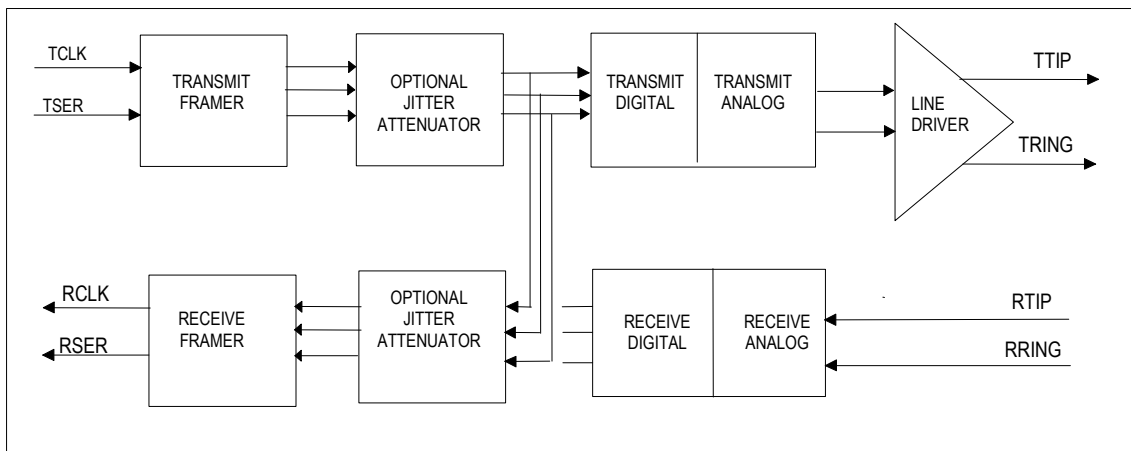
Figure 8-16. Analog Loopback



8.11.5.2 Local Loopback

The transmit system data (the internal signals TPOS, TNEG, and TCLK) is looped back to receive-side inputs to the receive jitter attenuator. The data is also output on TTIP and TRING. Signals at RTIP and RRING are ignored. This loopback is conceptually shown in [Figure 8-17](#).

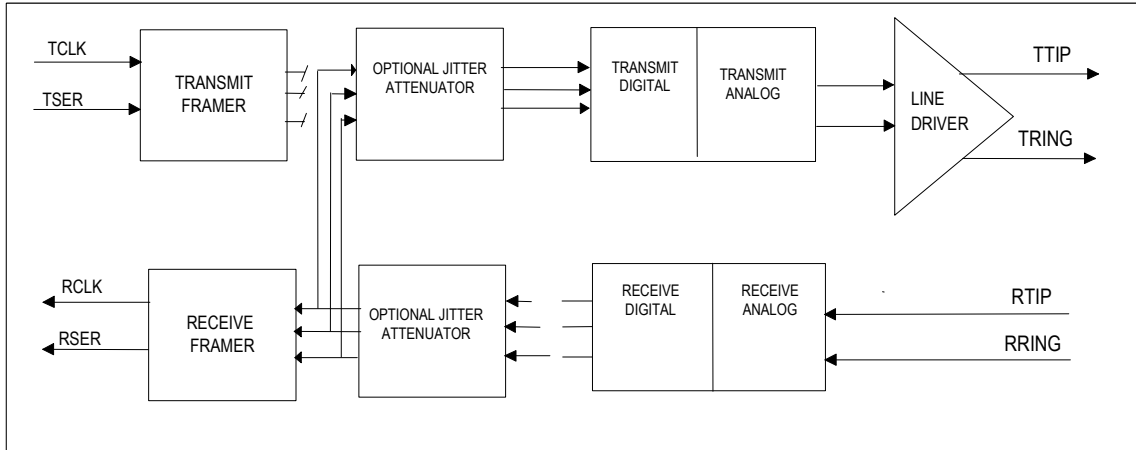
Figure 8-17. Local Loopback



8.11.5.3 Remote Loopback

The outputs decoded from the receive LIU are looped back to the transmit LIU. The inputs from the transmit framer are ignored during a remote loopback. This loopback is conceptually shown in [Figure 8-18](#).

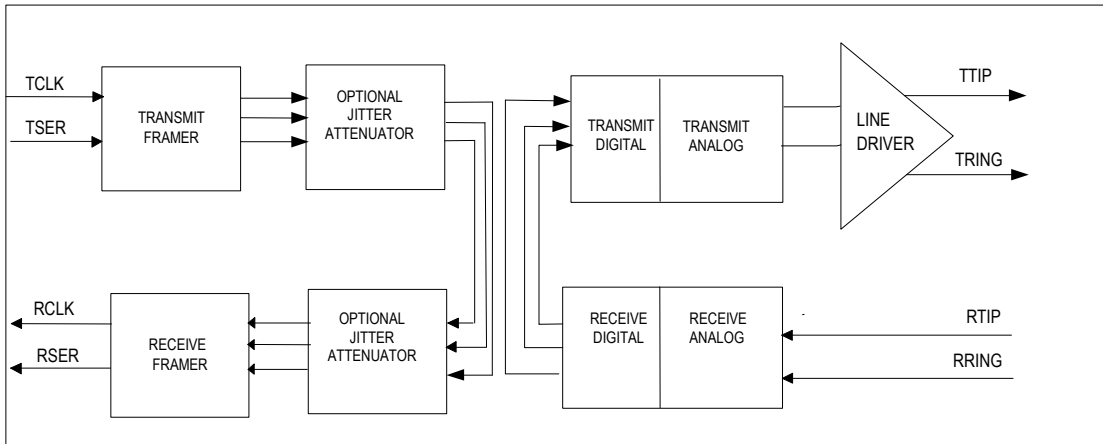
Figure 8-18. Remote Loopback



8.11.5.4 Dual Loopback

The inputs decoded from the receive LIU are looped back to the transmit LIU. The inputs from the transmit framer are looped back to the receiver with the optional jitter attenuator. This loopback is invoked if RLB and LLB are both set in the LIU Maintenance Control register ([LMCR](#)). This loopback is conceptually shown in [Figure 8-19](#).

Figure 8-19. Dual Loopback



8.12 Bit-Error-Rate Test (BERT) Function

The bit-error-rate tester (BERT) block can generate and detect both pseudorandom and repeating bit patterns. It is used to test and stress data-communication links. BERT functionality is dedicated for each of the transceivers. [Table 8-40](#) shows the registers related to the configure, control, and status of the BERT.

Table 8-40. Registers Related to BERT Configure, Control, and Status

REGISTER	FRAMER ADDRESSES	FUNCTION
Global BERT Interrupt Status Register (GBISR)	0FAh	When any of the four BERTs issue an interrupt, a bit is set.
Global BERT Interrupt Mask Register (GBIMR)	0FDh	When any of the four BERTs issue an interrupt, a bit is set.
Receive Expansion Port Control Register (RXPC)	08Ah	Enable for the receiver BERT.
Receive BERT Port Bit Suppress Register (RBPBS)	08Bh	Bit suppression for the receive BERT.
Receive BERT Port Channel Select Registers 1 to 4 (RBPCS1 : RBPCS4)	0D4h, 0D5h, 0D6h, 0D7h	Channels to be enabled for the framer to accept data from the BERT pattern generator.
Transmit Expansion Port Control Register (TXPC)	18Ah	Enable for the transmitter BERT
Transmit BERT Port Bit Suppress Register (TBPBS)	18Bh	Bit suppression for the transmit BERT
Transmit BERT Port Channel Select Registers 1 to 4 (TBPCS1 : TBPCS4)	1D4h, 1D5h, 1D6h, 1D7h	Channels to be enabled for the framer to accept data from the transmit BERT pattern generator.
BERT Alternating Word Count Rate Register (BAWC)	1100h	BERT alternating pattern count register.
BERT Repetitive Pattern Set Register 1 (BRP1)	1101h	BERT repetitive pattern set register 1.
BERT Repetitive Pattern Set Register 2 (BRP2)	1102h	BERT repetitive pattern set register 2.
BERT Repetitive Pattern Set Register 3 (BRP3)	1103h	BERT repetitive pattern set register 3.
BERT Repetitive Pattern Set Register 4 (BRP4)	1104h	BERT repetitive pattern set register 4.
BERT Control Register 1 (BC1)	1105h	Pattern selection and miscellaneous control.
BERT Control Register 2 (BC2)	1106h	BERT bit pattern length control.
BERT Bit Count Register 1 (BBC1)	1107h	BERT bit counter—increments for BERT bit clocks.
BERT Bit Count Register 2 (BBC2)	1108h	BERT bit counter.
BERT Bit Count Register 3 (BBC3)	1109h	BERT bit counter.
BERT Bit Count Register 4 (BBC4)	110Ah	BERT bit counter.
BERT Error Count Register 1 (BEC1)	110Bh	BERT error counter.
BERT Error Count Register 2 (BEC2)	110Ch	BERT error counter.
BERT Error Count Register 3 (BEC3)	110Dh	BERT error counter.
BERT Latched Status Register (BLSR)	110Eh	BERT status registers—denotes synchronization loss and other status.
BERT Status Interrupt Mask Register (BSIM)	110Fh	BERT Interrupt mask.

Note: The addresses shown are for Framer 1. Addresses for Framers 2 to 4 can be calculated using the following framer: Framer $n = (\text{Framer 1 address} + (n - 1) \times 200\text{h})$; where $n = 2$ to 4 for Framers 2 to 4.

The BERT block can generate and detect the following patterns:

- The pseudorandom patterns 2E7-1, 2E9-1, 2E11-1, 2E15-1, and QRSS
- A repetitive pattern from 1 to 32 bits in length
- Alternating (16-bit) words that flip every 1 to 256 words
- Daly pattern

The BERT function must be enabled and configured in the [TXPC](#) and [RXPC](#) registers for each port. The BERT can then be assigned on a per-channel basis for both the transmitter and receiver, using the special per-channel function in the [TBPCS1:TBPCS4](#) and [RBCS1:RBCS4](#) registers. Individual bit positions within the channels can be suppressed with the [TBPBS](#) and [RBPBS](#) registers. Using combinations of these functions, the BERT pattern can be transmitted and/or received in single or across multiple DS0s, contiguous or broken. Transmit and receive bandwidth assignments are independent of each other.

The BERT receiver has a 32-bit bit counter and a 24-bit error counter. The BERT receiver can generate interrupts on: a change in receive-synchronizer status, receive all zeros, receive all ones, error counter overflow, bit counter overflow, and bit error detection. Interrupts from each of these events can be masked within the BERT function via the BERT Status Interrupt Mask register ([BSIM](#)). If the software detects that the BERT has reported an event, then the software must read the BERT Latched Status register ([BLSR](#)) to determine which event(s) has occurred.

8.12.1 BERT Repetitive Pattern Set

These registers must be properly loaded for the BERT to generate and synchronize to a repetitive pattern, a pseudorandom pattern, alternating word pattern, or a Daly pattern. For a repetitive pattern that is fewer than 32 bits, the pattern should be repeated so that all 32 bits are used to describe the pattern. For example, if the pattern was the repeating 5-bit pattern ...01101... (where the rightmost bit is the one sent first and received first), then BRP1 should be loaded with ADh, BRP2 with B5h, BRP3 with D6h, and BRP4 should be loaded with 5Ah. For a pseudorandom pattern, all four registers should be loaded with all ones (i.e., FFh). For an alternating word pattern, one word should be placed into BRP1 and BRP2 and the other word should be placed into BRP3 and BRP4. For example, if the DDS stress pattern "7E" is to be described, the user would place 00h in BRP1, 00h in BRP2, 7Eh in BRP3, and 7Eh in BRP4, and the alternating word counter would be set to 50 (decimal) to allow 100 bytes of 00h followed by 100 bytes of 7Eh to be sent and received.

8.12.2 BERT Error Counter

Once the BERT has achieved synchronization, this 24-bit counter will increment for each data bit received in error. Toggling the LC control bit in BC1 can clear this counter. This counter saturates when full and will set the BECO status bit in the [BLSR](#) register.

9. DEVICE REGISTERS

Thirteen address bits are used to control the settings of the registers. The address map is compatible with the Dallas Semiconductor octal framer product, DS26528 and DS26401.

The registers control functions of the framers, LIU, and BERT within the DS26524. The map is divided into four framers, followed by four LIUs and four BERTs. Global registers (applicable to all four transceivers and BERTs) are located within the address space of Framer 1.

The bulk write mode is a special mode to write all four transceivers with one write command (see the [GTCR1](#) register). [Figure 9-1](#) shows the register map.

The register details are provided in the following tables. The framer registers bits are provided for Framer 0, and address bits A[11:8] determine the framer addressed.

9.1 Register Listings

Table 9-1. Register Address Ranges (in Hex)

CHANNEL	GLOBAL REGISTERS	RECEIVE FRAMER	TRANSMIT FRAMER	LIU	BERT
—	00F0–00FF	—	—	—	—
CH1	—	0000–00EF	0100–01EF	1000–101F	1100–110F
CH2	—	0200–02EF	0300–03EF	1020–103F	1110–111F
CH3	—	0400–04EF	0500–05EF	1040–105F	1120–112F
CH4	—	0600–06EF	0700–07EF	1060–107F	1130–113F

Figure 9-1. Register Memory Map for the DS26524

Adrs = 0000 0000 0000	Framer 1 Rx Regs 240 Regs	000
Adrs = 0000 1111 0000	Global Registers	0EF 0F0
Adrs = 0001 0000 0000	Framer 1 Tx Regs 240 Regs	0FF 100
Adrs = 0001 1111 0000	Reserved	1EF 1F0 1FF
Adrs = 0010 0000 0000	Framer 2 Regs	200
Adrs = 0100 0000 0000	Framer 3 Regs	3FF 400
Adrs = 0101 1111 1111 Adrs = 0110 0000 0000	Framer 4 Regs	5FF 600
Adrs = 0111 1111 1111 Adrs = 1000 0000 0000	Reserved	7FF 800
Adrs = 01111 1111 1111 Adrs = 10000 0000 0000	LIU Regs	FFF 1000
Adrs = 10000 1111 1111 Adrs = 10001 0000 0000	BERT	10FF 1100
Adrs = 10001 0111 1111	Reserved	117F
Adrs = 11111 1111 1111	Reserved	1FFF

9.1.1 Global Register List

Table 9-2. Global Register List

GLOBAL REGISTER LIST			
ADDRESS	NAME	DESCRIPTION	R/W
0F0h	GTCR1	Global Transceiver Control Register 1	R/W
0F1h	GFCR	Global Framer Control Register	R/W
0F2h	GTCR2	Global Transceiver Control Register 2	R/W
0F3h	GTCCR	Global Transceiver Clock Control Register	R/W
0F4h	—	Reserved	—
0F5h	GLSRR	Global LIU Software Reset Register	R/W
0F6h	GFSRR	Global Framer and BERT Software Reset Register	R/W
0F7h	—	Reserved	—
0F8h	IDR	Device Identification Register	R
0F9h	GFISR	Global Framer Interrupt Status Register	R
0FAh	GBISR	Global BERT Interrupt Status Register	R
0FBh	GLISR	Global LIU Interrupt Status Register	R
0FCh	GFIMR	Global Framer Interrupt Mask Register	R/W
0FDh	GBIMR	Global BERT Interrupt Mask Register	R/W
0FEh	GLIMR	Global LIU Interrupt Mask Register	R/W
01Fh	—	Reserved	—

Note 1: Reserved registers should only be written with all zeros.

Note 2: The global registers are located in the framer address space. The corresponding address space for the other framers is "Reserved," and should be initialized with all zeros for proper operation.

9.1.2 Framer Register List

Table 9-3. Framer Register List

Note: Only the Framer 1 address is presented here. The same set of register definitions applies for transceiver 2 to 4 in accordance with the DS26524 map offsets. Transceiver offset is $(n - 1) \times 200$ hex, where n designates the transceiver in question.

FRAMER REGISTER LIST			
ADDRESS	NAME	DESCRIPTION	R/W
000h–00Fh	—	Reserved	—
010h	RHC	Receive HDLC Control Register	R/W
011h	RHBSE	Receive HDLC Bit Suppress Register	R/W
012h	RDS0SEL	Receive Channel Monitor Select Register	R/W
013h	RSIGC	Receive-Signaling Control Register	R/W
014h	T1RCR2	Receive Control Register 2 (T1 Mode)	R/W
	E1RSAIMR	Receive Sa-Bit Interrupt Mask Register (E1 Mode)	
015h	T1RBOCC	Receive BOC Control Register (T1 Mode Only)	R/W
016h–01Fh	—	Reserved	—
020h	RIDR1	Receive Idle Code Definition Register 1	R/W
021h	RIDR2	Receive Idle Code Definition Register 2	R/W
022h	RIDR3	Receive Idle Code Definition Register 3	R/W
023h	RIDR4	Receive Idle Code Definition Register 4	R/W
024h	RIDR5	Receive Idle Code Definition Register 5	R/W
025h	RIDR6	Receive Idle Code Definition Register 6	R/W
026h	RIDR7	Receive Idle Code Definition Register 7	R/W
027h	RIDR8	Receive Idle Code Definition Register 8	R/W
028h	RIDR9	Receive Idle Code Definition Register 9	R/W
029h	RIDR10	Receive Idle Code Definition Register 10	R/W
02Ah	RIDR11	Receive Idle Code Definition Register 11	R/W
02Bh	RIDR12	Receive Idle Code Definition Register 12	R/W
02Ch	RIDR13	Receive Idle Code Definition Register 13	R/W
02Dh	RIDR14	Receive Idle Code Definition Register 14	R/W
02Eh	RIDR15	Receive Idle Code Definition Register 15	R/W
02Fh	RIDR16	Receive Idle Code Definition Register 16	R/W
030h	RIDR17	Receive Idle Code Definition Register 17	R/W
031h	RIDR18	Receive Idle Code Definition Register 18	R/W
032h	RIDR19	Receive Idle Code Definition Register 19	R/W
033h	RIDR20	Receive Idle Code Definition Register 20	R/W
034h	RIDR21	Receive Idle Code Definition Register 21	R/W
035h	RIDR22	Receive Idle Code Definition Register 22	R/W
036h	RIDR23	Receive Idle Code Definition Register 23	R/W
037h	RIDR24	Receive Idle Code Definition Register 24	R/W
038h	T1RSAOI1	Receive-Signaling All-Ones Insertion Register 1 (T1 Mode Only)	R/W
	RIDR25	Receive Idle Code Definition Register 25 (E1 Mode)	
039h	T1RSAOI2	Receive-Signaling All-Ones Insertion Register 2 (T1 Mode Only)	R/W
	RIDR26	Receive Idle Code Definition Register 26 (E1 Mode)	
03Ah	T1RSAOI3	Receive-Signaling All-Ones Insertion Register 3 (T1 Mode Only)	R/W
	RIDR27	Receive Idle Code Definition Register 27 (E1 Mode)	
03B	RIDR28	Receive Idle Code Definition Register 28 (E1 Mode)	—
03C	T1RDMWE1	T1 Receive Digital Milliwatt Enable Register 1 (T1 Mode Only)	R/W
	RIDR29	Receive Idle Code Definition Register 29 (E1 Mode)	
03Dh	T1RDMWE2	T1 Receive Digital Milliwatt Enable Register 2 (T1 Mode Only)	R/W
	RIDR30	Receive Idle Code Definition Register 30 (E1 Mode)	
03Eh	T1RDMWE3	T1 Receive Digital Milliwatt Enable Register 3 (T1 Mode Only)	R/W
	RIDR31	Receive Idle Code Definition Register 31 (E1 Mode)	

FRAMER REGISTER LIST			
ADDRESS	NAME	DESCRIPTION	R/W
03Fh	RIDR32	Receive Idle Code Definition Register 32 (E1 Mode)	—
040h	RS1	Receive-Signaling Register 1	R
041h	RS2	Receive-Signaling Register 2	R
042h	RS3	Receive-Signaling Register 3	R
043h	RS4	Receive-Signaling Register 4	R
044h	RS5	Receive-Signaling Register 5	R
045h	RS6	Receive-Signaling Register 6	R
046h	RS7	Receive-Signaling Register 7	R
047h	RS8	Receive-Signaling Register 8	R
048h	RS9	Receive-Signaling Register 9	R
049h	RS10	Receive-Signaling Register 10	R
04Ah	RS11	Receive-Signaling Register 11	R
04Bh	RS12	Receive-Signaling Register 12	R
04Ch	RS13	Receive-Signaling Register 13 (E1 Mode only)	—
04Dh	RS14	Receive-Signaling Register 14 (E1 Mode only)	—
04Eh	RS15	Receive-Signaling Register 15 (E1 Mode only)	—
04Fh	RS16	Receive-Signaling Register 16 (E1 Mode only)	—
050h	LCVCR1	Line Code Violation Count Register 1	R
051h	LCVCR2	Line Code Violation Count Register 2	R
052h	PCVCR1	Path Code Violation Count Register 1	R
053h	PCVCR2	Path Code Violation Count Register 2	R
054h	FOSCR1	Frames Out of Sync Count Register 1	R
055h	FOSCR2	Frames Out of Sync Count Register 2	R
056h	E1EBCR1	E-Bit Counter 1 (E1 Mode Only)	R
057h	E1EBCR2	E-Bit Counter 2 (E1 Mode Only)	R
058h–05Fh	—	Reserved	—
060	RDS0M	Receive DS0 Monitor Register	R
061	—	Reserved	—
062h	T1RFDL	Receive FDL Register (T1 Mode)	R
	E1RRTS7	Receive Real-Time Status Register 7 (E1 Mode)	
063h	T1RBOC	Receive BOC Register (T1 Mode)	R
064h	T1RSLC1	Receive SLC-96 Data Link Register 1 (T1 Mode)	R
	E1RAF	E1 Receive Align Frame Register (E1 Mode)	
065h	T1RSLC2	Receive SLC-96 Data Link Register 2 (T1 Mode)	R
	E1RNAF	E1 Receive Non-Align Frame Register (E1 Mode)	
066h	T1RSLC3	Receive SLC-96 Data Link Register 3 (T1 Mode)	R
	E1RSiAF	E1 Received Si Bits of the Align Frame Register (E1 Mode)	
067h	E1RSiNAF	Received Si Bits of the Non-Align Frame Register (E1 Mode)	R
068h	E1RRA	Received Remote Alarm Register (E1 Mode)	R
069h	E1RSa4	E1 Receive Sa4 Bits Register (E1 Mode Only)	R
06Ah	E1RSa5	E1 Receive Sa5 Bits Register (E1 Mode Only)	R
06Bh	E1RSa6	E1 Receive Sa6 Bits Register (E1 Mode Only)	R
06Ch	E1RSa7	E1 Receive Sa7 Bits Register (E1 Mode Only)	R
06Dh	E1RSa8	Receive Sa8 Bits Register (E1 Mode Only)	R
06Eh	SaBITS	E1 Receive SaX Bits Register	R
06Fh	Sa6CODE	Received Sa6 Codeword Register	R
070h–07Fh	—	Reserved	—
080h	RMMR	Receive Master Mode Register	R/W
081h	RCR1	Receive Control Register 1 (T1 Mode)	R/W
	RCR1	Receive Control Register 1 (E1 Mode)	
082h	T1RIBCC	Receive In-Band Code Control Register (T1 Mode)	R/W
	E1RCR2	Receive Control Register 2 (E1 Mode)	

FRAMER REGISTER LIST			
ADDRESS	NAME	DESCRIPTION	R/W
083h	RCR3	Receive Control Register 3	R/W
084h	RIOCR	Receive I/O Configuration Register	R/W
085h	RESCR	Receive Elastic Store Control Register	R/W
086h	ERCNT	Error-Counter Configuration Register	R/W
087h	RHFC	Receive HDLC FIFO Control Register	R/W
088h	RIBOC	Receive Interleave Bus Operation Control Register	R/W
089h	T1RSCC	In-Band Receive Spare Control Register (T1 Mode Only)	R/W
08Ah	RXPC	Receive Expansion Port Control Register	R/W
08B	RBPBS	Receive BERT Port Bit Suppress Register	R/W
08Ch–08Fh	—	Reserved	—
090h	RLS1	Receive Latched Status Register 1	R/W
091h	RLS2	Receive Latched Status Register 2	R/W
092h	RLS3	Receive Latched Status Register 3	R/W
093	RLS4	Receive Latched Status Register 4	R/W
094h	RLS5	Receive Latched Status Register 5 (HDLC)	R/W
095h	—	Reserved	—
096h	RLS7	Receive Latched Status Register 7 (T1 Mode)	R/W
	RLS7	Receive Latched Status Register 7 (E1 Mode)	
097h	—	Reserved	—
098h	RSS1	Receive-Signaling Status Register 1	R/W
099h	RSS2	Receive-Signaling Status Register 2	R/W
09Ah	RSS3	Receive-Signaling Status Register 3	R/W
09Bh	RSS4	Receive-Signaling Status Register 4 (E1 Mode Only)	R/W
09Ch	T1RSCD1	Receive Spare Code Definition Register 1 (T1 Mode Only)	R/W
09Dh	T1RSCD2	Receive Spare Code Definition Register 2 (T1 Mode Only)	R/W
09Eh	—	Reserved	—
09Fh	RIIR	Receive Interrupt Information Register	R/W
0A0h	RIM1	Receive Interrupt Mask Register 1	R/W
0A1h	RIM2	Receive Interrupt Mask Register 2 (E1 Mode Only)	R/W
0A2h	RIM3	Receive Interrupt Mask Register 3 (T1 Mode)	R/W
	RIM3	Receive Interrupt Mask Register 3 (E1 Mode)	
0A3h	RIM4	Receive Interrupt Mask Register 4	R/W
0A4h	RIM5	Receive Interrupt Mask Register 5 (HDLC)	R/W
0A5h	—	Reserved	—
0A6h	RIM7	Receive Interrupt Mask Register 7 (T1 Mode)	R/W
0A7h	—	Reserved	—
0A8h	RSCSE1	Receive-Signaling Change of State Enable Register 1	R/W
0A9h	RSCSE2	Receive-Signaling Change of State Enable Register 2	R/W
0AAh	RSCSE3	Receive-Signaling Change of State Enable Register 3	R/W
0ABh	RSCSE4	Receive-Signaling Change of State Enable Register 4 (E1 Mode Only)	—
0ACh	T1RUPCD1	Receive Up Code Definition Register 1 (T1 Mode Only)	R/W
0ADh	T1RUPCD2	Receive Up Code Definition Register 2 (T1 Mode Only)	R/W
0AEh	T1RDNCD1	Receive Down Code Definition Register 1 (T1 Mode Only)	R/W
0AFh	T1RDNCD2	Receive Down Code Definition Register 2 (T1 Mode Only)	R/W
0B0h	RRTS1	Receive Real-Time Status Register 1	R
0B1h	—	Reserved	—
0B2h	RRTS3	Receive Real-Time Status Register 3 (T1 Mode)	R
	RRTS3	Receive Real-Time Status Register 3 (E1 Mode)	
0B3h	—	Reserved	—
0B4h	RRTS5	Receive Real-Time Status Register 5 (HDLC)	R
0B5h	RHPBA	Receive HDLC Packet Bytes Available Register	R
0B6h	RHF	Receive HDLC FIFO Register	R

FRAMER REGISTER LIST			
ADDRESS	NAME	DESCRIPTION	R/W
0B7h–0BFh	—	Reserved	—
0C0h	RBCS1	Receive Blank Channel Select Register 1	R/W
0C1h	RBCS2	Receive Blank Channel Select Register 2	R/W
0C2h	RBCS3	Receive Blank Channel Select Register 3	R/W
0C3h	RBCS4	Receive Blank Channel Select Register 4 (E1 Mode Only)	R/W
0C4h	RCBR1	Receive Channel Blocking Register 1	R/W
0C5h	RCBR2	Receive Channel Blocking Register 2	R/W
0C6h	RCBR3	Receive Channel Blocking Register 3	R/W
0C7h	RCBR4	Receive Channel Blocking Register 4 (E1 Mode Only)	R/W
0C8h	RSI1	Receive-Signaling Reinsertion Enable Register 1	R/W
0C9h	RSI2	Receive-Signaling Reinsertion Enable Register 2	R/W
0CAh	RSI3	Receive-Signaling Reinsertion Enable Register 3	R/W
0CBh	RSI4	Receive-Signaling Reinsertion Enable Register 4 (E1 Mode Only)	R/W
0CCh	RGCCS1	Receive Gapped Clock Channel Select Register 1	R/W
0CDh	RGCCS2	Receive Gapped Clock Channel Select Register 2	R/W
0CEh	RGCCS3	Receive Gapped Clock Channel Select Register 3	R/W
0CFh	RGCCS4	Receive Gapped Clock Channel Select Register (E1 Mode Only)	R/W
0D0h	RCICE1	Receive Channel Idle Code Enable Register 1	R/W
0D1h	RCICE2	Receive Channel Idle Code Enable Register 2	R/W
0D2h	RCICE3	Receive Channel Idle Code Enable Register 3	R/W
0D3h	RCICE4	Receive Channel Idle Code Enable Register 4 (E1 Mode Only)	R/W
0D4h	RBPCS1	Receive BERT Port Channel Select Register 1	R/W
0D5h	RBPCS2	Receive BERT Port Channel Select Register 2	R/W
0D6h	RBPCS3	Receive BERT Port Channel Select Register 3	R/W
0D7h	RBPCS4	Receive BERT Port Channel Select Register (E1 Mode Only)	R/W
0D8h–0EFh	—	Reserved	—
0F0h–0FFh	Global Registers (Section 9.3)	See the Global Register list in Table 9-2 . Note that this space is “Reserved” in Framers 2 to 4.	R/W
100h–10Fh	—	Reserved	—
110h	THC1	Transmit HDLC Control Register 1	R/W
111h	THBSE	Transmit HDLC Bit Suppress Register	R/W
112h	—	Reserved	—
113h	THC2	Transmit HDLC Control Register 2	R/W
114h	E1TSACR	E1 Transmit Sa-Bit Control Register (E1 Mode)	R/W
115h–117h	—	Reserved	—
118h	SSIE1	Software-Signaling Insertion Enable Register 1	R/W
119h	SSIE2	Software-Signaling Insertion Enable Register 2	R/W
11Ah	SSIE3	Software-Signaling Insertion Enable Register 3	R/W
11Bh	SSIE4	Software-Signaling Insertion Enable Register 4 (E1 Mode Only)	R/W
11Ch–11Fh	—	Reserved	—
120h	TIDR1	Transmit Idle Code Definition Register 1	R/W
121h	TIDR2	Transmit Idle Code Definition Register 2	R/W
122h	TIDR3	Transmit Idle Code Definition Register 3	R/W
123h	TIDR4	Transmit Idle Code Definition Register 4	R/W
124h	TIDR5	Transmit Idle Code Definition Register 5	R/W
125h	TIDR6	Transmit Idle Code Definition Register 6	R/W
126h	TIDR7	Transmit Idle Code Definition Register 7	R/W
127h	TIDR8	Transmit Idle Code Definition Register 8	R/W
128h	TIDR9	Transmit Idle Code Definition Register 9	R/W
129h	TIDR10	Transmit Idle Code Definition Register 10	R/W
12Ah	TIDR11	Transmit Idle Code Definition Register 11	R/W

FRAMER REGISTER LIST			
ADDRESS	NAME	DESCRIPTION	R/W
12Bh	TIDR12	Transmit Idle Code Definition Register 12	R/W
12Ch	TIDR13	Transmit Idle Code Definition Register 13	R/W
12Dh	TIDR14	Transmit Idle Code Definition Register 14	R/W
12Eh	TIDR15	Transmit Idle Code Definition Register 15	R/W
12Fh	TIDR16	Transmit Idle Code Definition Register 16	R/W
130h	TIDR17	Transmit Idle Code Definition Register 17	R/W
131h	TIDR18	Transmit Idle Code Definition Register 18	R/W
132h	TIDR19	Transmit Idle Code Definition Register 19	R/W
133h	TIDR20	Transmit Idle Code Definition Register 20	R/W
134h	TIDR21	Transmit Idle Code Definition Register 21	R/W
135h	TIDR22	Transmit Idle Code Definition Register 22	R/W
136h	TIDR23	Transmit Idle Code Definition Register 23	R/W
137h	TIDR24	Transmit Idle Code Definition Register 24	R/W
138h	TIDR25	Transmit Idle Code Definition Register 25 (E1 Mode Only)	R/W
139h	TIDR26	Transmit Idle Code Definition Register 26 (E1 Mode Only)	R/W
13Ah	TIDR27	Transmit Idle Code Definition Register 27 (E1 Mode Only)	R/W
13Bh	TIDR28	Transmit Idle Code Definition Register 28 (E1 Mode Only)	R/W
13Ch	TIDR29	Transmit Idle Code Definition Register 29 (E1 Mode Only)	R/W
13Dh	TIDR30	Transmit Idle Code Definition Register 30 (E1 Mode Only)	R/W
13Eh	TIDR31	Transmit Idle Code Definition Register 31 (E1 Mode Only)	R/W
13Fh	TIDR32	Transmit Idle Code Definition Register 32 (E1 Mode Only)	R/W
140h	TS1	Transmit-Signaling Register 1	R/W
141h	TS2	Transmit-Signaling Register 2	R/W
142h	TS3	Transmit-Signaling Register 3	R/W
143h	TS4	Transmit-Signaling Register 4	R/W
144h	TS5	Transmit-Signaling Register 5	R/W
145h	TS6	Transmit-Signaling Register 6	R/W
146h	TS7	Transmit-Signaling Register 7	R/W
147h	TS8	Transmit-Signaling Register 8	R/W
148h	TS9	Transmit-Signaling Register 9	R/W
149h	TS10	Transmit-Signaling Register 10	R/W
14Ah	TS11	Transmit-Signaling Register 11	R/W
14Bh	TS12	Transmit-Signaling Register 12	R/W
14Ch	TS13	Transmit-Signaling Register 13	R/W
14Dh	TS14	Transmit-Signaling Register 14	R/W
14Eh	TS15	Transmit-Signaling Register 15	R/W
14Fh	TS16	Transmit-Signaling Register 16	R/W
150h	TCICE1	Transmit Channel Idle Code Enable Register 1	R/W
151h	TCICE2	Transmit Channel Idle Code Enable Register 2	R/W
152h	TCICE3	Transmit Channel Idle Code Enable Register 3	R/W
153h	TCICE4	Transmit Channel Idle Code Enable Register 4 (E1 Mode Only)	R/W
154h–161h	—	Reserved	—
162h	T1TFDL	Transmit FDL Register (T1 Mode Only)	R/W
163h	T1TBOC	Transmit BOC Register (T1 Mode Only)	R/W
164h	T1TSLC1	Transmit SLC-96 Data Link Register 1 (T1 Mode)	R/W
	E1TAF	Transmit Align Frame Register (E1 Mode)	
165h	T1TSLC2	Transmit SLC-96 Data Link Register 2 (T1 Mode)	R/W
	E1TNAF	Transmit Non-Align Frame Register (E1 Mode)	
166h	T1TSLC3	Transmit SLC-96 Data Link Register 3 (T1 Mode)	R/W
	E1TSiAF	Transmit Si Bits of the Align Frame Register (E1 Mode)	
167h	E1TSiNAF	Transmit Si Bits of the Non-Align Frame Register (E1 Mode Only)	R/W
168h	E1TRA	Transmit Remote Alarm Register (E1 Mode)	R/W

FRAMER REGISTER LIST			
ADDRESS	NAME	DESCRIPTION	R/W
169h	E1TSa4	Transmit Sa4 Bits Register (E1 Mode Only)	R/W
16Ah	E1TSa5	Transmit Sa5 Bits Register (E1 Mode Only)	R/W
16Bh	E1TSa6	Transmit Sa6 Bits Register (E1 Mode Only)	R/W
16Ch	E1TSa7	Transmit Sa7 Bits Register (E1 Mode Only)	R/W
16Dh	E1RSa8	Receive Sa8 Bits Register (E1 Mode Only)	R/W
16Eh–17Fh	—	Reserved	—
180h	TMMR	Transmit Master Mode Register	R/W
181h	TCR1	Transmit Control Register 1 (T1 Mode)	R/W
	TCR1	Transmit Control Register 1 (E1 Mode)	
182h	TCR2	Transmit Control Register 2 (T1 Mode)	R/W
	TCR2	Transmit Control Register 2 (E1 Mode)	
183h	TCR3	Transmit Control Register 3	R/W
184h	TIOCR	Transmit I/O Configuration Register	R/W
185h	TESCR	Transmit Elastic Store Control Register	R/W
186h	TCR4	Transmit Control Register 4 (T1 Mode Only)	R/W
187h	THFC	Transmit HDLC FIFO Control Register	R/W
188h	TIBOC	Transmit Interleave Bus Operation Control Register	R/W
189h	TDS0SEL	Transmit DS0 Channel Monitor Select Register	R/W
18Ah	TXPC	Transmit Expansion Port Control Register	R/W
18Bh	TBPBS	Transmit BERT Port Bit Suppress Register	R/W
18Ch–18Dh	—	Reserved	—
18Eh	TSYNCC	Transmit Synchronizer Control Register	R/W
18F	—	Reserved	—
190h	TLS1	Transmit Latched Status Register 1	R/W
191h	TLS2	Transmit Latched Status Register 2 (HDLC)	R/W
192h	TLS3	Transmit Latched Status Register 3 (Synchronizer)	R/W
193h–19Eh	—	Reserved	—
19Fh	TIIR	Transmit Interrupt Information Register	R/W
1A0h	TIM1	Transmit Interrupt Mask Register 1	R/W
1A1h	TIM2	Transmit Interrupt Mask Register 2 (HDLC)	R/W
1A2h	TIM3	Transmit Interrupt Mask Register 3 (Synchronizer)	R/W
1A3h–1ABh	—	Reserved	—
1ACh	T1TCD1	Transmit Code Definition Register 1 (T1 Mode Only)	R/W
1ADh	T1TCD2	Transmit Code Definition Register 2 (T1 Mode Only)	R/W
1AEh–1B0h	—	Reserved	—
1B1h	TRTS2	Transmit Real-Time Status Register 2 (HDLC)	R
1B2h	—	Reserved	—
1B3h	TFBA	Transmit HDLC FIFO Buffer Available	R
1B4h	THF	Transmit HDLC FIFO Register	W
1B5h–1BhA	—	Reserved	—
1BBh	TDS0M	Transmit DS0 Monitor Register	R
1BCh–1BFh	—	Reserved	—
1C0h	TBCS1	Transmit Blank Channel Select Register 1	R/W
1C1h	TBCS2	Transmit Blank Channel Select Register 2	R/W
1C2h	TBCS3	Transmit Blank Channel Select Register 3	R/W
1C3h	TBCS4	Transmit Blank Channel Select Register 4 (E1 Mode Only)	R/W
1C4h	TCBR1	Transmit Channel Blocking Register 1	R/W
1C5h	TCBR2	Transmit Channel Blocking Register 2	R/W
1C6h	TCBR3	Transmit Channel Blocking Register 3	R/W
1C7h	TCBR4	Transmit Channel Blocking Register 4 (E1 Mode Only)	R/W
1C8h	THSCS1	Transmit Hardware-Signaling Channel Select Register 1	R/W
1C9h	THSCS2	Transmit Hardware-Signaling Channel Select Register 2	R/W

FRAMER REGISTER LIST			
ADDRESS	NAME	DESCRIPTION	R/W
1CAh	THSCS3	Transmit Hardware-Signaling Channel Select Register 3	R/W
1CBh	THSCS4	Transmit Hardware-Signaling Channel Select Register 4 (E1 Mode Only)	R/W
1CCh	TGCCS1	Transmit Gapped-Clock Channel Select Register 1	R/W
1CDh	TGCCS2	Transmit Gapped-Clock Channel Select Register 2	R/W
1CEh	TGCCS3	Transmit Gapped-Clock Channel Select Register 3	R/W
1CFh	TGCCS4	Transmit Gapped-Clock Channel Select Register 4 (E1 Mode Only)	R/W
1D0h	PCL1	Per-Channel Loopback Enable Register 1	R/W
1D1h	PCL2	Per-Channel Loopback Enable Register 2	R/W
1D2h	PCL3	Per-Channel Loopback Enable Register 3	R/W
1D3h	PCL4	Per-Channel Loopback Enable Register 4 (E1 Mode Only)	R/W
1D4h	TBPCS1	Transmit BERT Port Channel Select Register 1	R/W
1D5h	TBPCS2	Transmit BERT Port Channel Select Register 2	R/W
1D6h	TBPCS3	Transmit BERT Port Channel Select Register 3	R/W
1D7h	TBPCS4	Transmit BERT Port Channel Select Register 4 (E1 Mode Only)	R/W
1D8h–1FFh	—	Reserved	—

9.1.3 LIU and BERT Register List

Table 9-4. LIU Register List

LIU REGISTER LIST		
ADDRESS	NAME	DESCRIPTION
1000h	LTRCR	LIU Transmit Receive Control Register
1001h	LTITSR	LIU Transmit Impedance and Pulse Shape Selection Register
1002h	LMCR	LIU Maintenance Control Register
1003h	LRSR	LIU Real Status Register
1004h	LSIMR	LIU Status Interrupt Mask Register
1005h	LLSR	LIU Latched Status Register
1006h	LRSL	LIU Receive Signal Level Register
1007	LRISMR	LIU Receive Impedance and Sensitivity Monitor Register
1008h–101Fh	—	Reserved

Table 9-5. BERT Register List

BERT REGISTER LIST		
ADDRESS	NAME	DESCRIPTION
1100h	BAWC	BERT Alternating Word Count Rate Register
1101h	BRP1	BERT Repetitive Pattern Set Register 1
1102h	BRP2	BERT Repetitive Pattern Set Register 2
1103h	BRP3	BERT Repetitive Pattern Set Register 3
1104h	BRP4	BERT Repetitive Pattern Set Register 4
1105h	BC1	BERT Control Register 1
1106h	BC2	BERT Control Register 2
1107h	BBC1	BERT Bit Count Register 1
1108h	BBC2	BERT Bit Count Register 2
1109h	BBC3	BERT Bit Count Register 3
110Ah	BBC4	BERT Bit Count Register 4
110Bh	BEC1	BERT Error Count Register 1
110Ch	BEC2	BERT Error Count Register 2
110Dh	BEC3	BERT Error Count Register 3
110Eh	BLSR	BERT Latched Status Register
110Fh	BSIM	BERT Status Interrupt Mask Register

9.2 Register Bit Maps

9.2.1 Global Register Bit Map

Table 9-6. Global Register Bit Map

ADDR	NAME	BIT 7	BIT 6	BIT 5	BIT 4	BIT 3	BIT 2	BIT 1	BIT 0
0F0h	GTCR1	—	—	RLOFLTS	GIBO	—	BWE	GCLE	GIPI
0F1h	GFCCR	IBOMS1	IBOMS0	BPCLK1	BPCLK0	RFLOSSFS	RFMSS	TCBCS	RCBCS
0F2h	GTCR2	—	—	—	—	—	LOSS	TSSYNCEOSEL	—
0F3h	GTCCR	BPREFSEL3	BPREFSEL2	BPREFSEL1	BPREFSEL0	BFREQSEL	FREQSEL	MPS1	MPS0
0F4h	—	—	—	—	—	—	—	—	—
0F5h	GLSRR	—	—	—	—	LSRST4	LSRST3	LSRST2	LSRST1
0F6h	GFSRR	—	—	—	—	FSRST4	FSRST3	FSRST2	FSRST1
0F7h	—	—	—	—	—	—	—	—	—
0F8h	IDR	ID7	ID6	ID5	ID4	ID3	ID2	ID1	ID0
0F9h	GFISR	—	—	—	—	FIS4	FIS3	FIS2	FIS1
0Fah	GBISR	—	—	—	—	BIS4	BIS3	BIS2	BIS1
0FBh	GLISR	—	—	—	—	LIS4	LIS3	LIS2	LIS1
0FCh	GFIMR	—	—	—	—	FIM4	FIM3	FIM2	FIM1
0FDh	GBIMR	—	—	—	—	BIM4	BIM3	BIM2	BIM1
0FEh	GLIMR	—	—	—	—	LIM4	LIM3	LIM2	LIM1

9.2.2 Framer Register Bit Map

[Table 9-7](#) contains the framer registers of the DS26524. Some registers have dual functionality based on the selection of T1/J1 or E1 operating mode in the [RMMR](#) and [TMMR](#) registers. These dual-function registers are shown below using two lines of text. The first line of text is the bit functionality for T1/J1 mode. The second line is the bit functionality in E1 mode, in *italics*. Bits that are not used for an operating mode are noted with a dash “—”. When there is only one set of bit definitions listed for a register, the bit functionality does not change with respect to the selection of T1/J1 or E1 mode. All registers not listed are reserved and should be initialized with a value of 00h for proper operation. The addresses shown are for Framer 1. Addresses for Framer 2 to 4 can be calculated using the following formula: Address for Framer N = (Framer 1 address + (N - 1) x 200h).

Table 9-7. Framer Register Bit Map

ADDR	NAME	BIT 7	BIT 6	BIT 5	BIT 4	BIT 3	BIT 2	BIT 1	BIT 0
010h	RHC	RCRCD	RHR	RHMS	RHCS4	RHCS3	RHCS2	RHCS1	RHCS0
011h	RHBSE	BSE8	BSE7	BSE6	BSE5	BSE4	BSE3	BSE2	BSE1
012h	RDS0SEL	—	—	—	RCM4	RCM3	RCM2	RCM1	RCM0
013h	RSIGC	—	—	—	RFSA1	—	RSFF	RSFE	RSIE
		—	—	—	CASMS	—	RSFF	RSFE	RSEI
014h	T1RCR2	—	—	—	RSLC96	OOF2	OOF1	RAIIE	RD4RM
	E1RSAIMR	—	—	—	<i>RSa4IM</i>	<i>RSa5IM</i>	<i>RSa6IM</i>	<i>RSa7IM</i>	<i>RSa8IM</i>
015h	T1RBOCC	RBR	—	RBD1	RBD0	—	RBF1	RBF0	—
020h	RIDR1	C7	C6	C5	C4	C3	C2	C1	C0
021h	RIDR2	C7	C6	C5	C4	C3	C2	C1	C0
022h	RIDR3	C7	C6	C5	C4	C3	C2	C1	C0
023h	RIDR4	C7	C6	C5	C4	C3	C2	C1	C0
024h	RIDR5	C7	C6	C5	C4	C3	C2	C1	C0
025h	RIDR6	C7	C6	C5	C4	C3	C2	C1	C0
026h	RIDR7	C7	C6	C5	C4	C3	C2	C1	C0
027h	RIDR8	C7	C6	C5	C4	C3	C2	C1	C0
028h	RIDR9	C7	C6	C5	C4	C3	C2	C1	C0
029h	RIDR10	C7	C6	C5	C4	C3	C2	C1	C0
02Ah	RIDR11	C7	C6	C5	C4	C3	C2	C1	C0
02Bh	RIDR12	C7	C6	C5	C4	C3	C2	C1	C0
02Ch	RIDR13	C7	C6	C5	C4	C3	C2	C1	C0
02Dh	RIDR14	C7	C6	C5	C4	C3	C2	C1	C0
02Eh	RIDR15	C7	C6	C5	C4	C3	C2	C1	C0
02Fh	RIDR16	C7	C6	C5	C4	C3	C2	C1	C0
030h	RIDR17	C7	C6	C5	C4	C3	C2	C1	C0
031h	RIDR18	C7	C6	C5	C4	C3	C2	C1	C0
032h	RIDR19	C7	C6	C5	C4	C3	C2	C1	C0
033h	RIDR20	C7	C6	C5	C4	C3	C2	C1	C0
034h	RIDR21	C7	C6	C5	C4	C3	C2	C1	C0
035h	RIDR22	C7	C6	C5	C4	C3	C2	C1	C0
036h	RIDR23	C7	C6	C5	C4	C3	C2	C1	C0
037h	RIDR24	C7	C6	C5	C4	C3	C2	C1	C0
038h	T1RSAOI1	CH8	CH7	CH6	CH5	CH4	CH3	CH2	CH1
	<i>RIDR25</i>	<i>C7</i>	<i>C6</i>	<i>C5</i>	<i>C4</i>	<i>C3</i>	<i>C2</i>	<i>C1</i>	<i>C0</i>
039h	T1RSAOI2	CH16	CH15	CH14	CH13	CH12	CH11	CH10	CH9
	<i>RIDR26</i>	<i>C7</i>	<i>C6</i>	<i>C5</i>	<i>C4</i>	<i>C3</i>	<i>C2</i>	<i>C1</i>	<i>C0</i>
03Ah	T1RSAOI3	CH24	CH23	CH22	CH21	CH20	CH19	CH18	CH17
	<i>RIDR27</i>	<i>C7</i>	<i>C6</i>	<i>C5</i>	<i>C4</i>	<i>C3</i>	<i>C2</i>	<i>C1</i>	<i>C0</i>

ADDR	NAME	BIT 7	BIT 6	BIT 5	BIT 4	BIT 3	BIT 2	BIT 1	BIT 0
03Bh	RIDR28	—	—	—	—	—	—	—	—
		C7	C6	C5	C4	C3	C2	C1	C0
03Ch	T1RDMWE1	CH8	CH7	CH6	CH5	CH4	CH3	CH2	CH1
	RIDR29	C7	C6	C5	C4	C3	C2	C1	C0
03Dh	T1RDMWE2	CH16	CH15	CH14	CH13	CH12	CH11	CH10	CH9
	RIDR30	C7	C6	C5	C4	C3	C2	C1	C0
03Eh	T1RDMWE3	CH24	CH23	CH22	CH21	CH20	CH19	CH18	CH17
	RIDR31	C7	C6	C5	C4	C3	C2	C1	C0
03Fh	RIDR32	—	—	—	—	—	—	—	—
		C7	C6	C5	C4	C3	C2	C1	C0
040h	RS1	CH1-A	CH1-B	CH1-C	CH1-D	CH13-A	CH13-B	CH13-C	CH13-D
		0	0	0	0	X	Y	X	X
041h	RS2	CH2-A	CH2-B	CH2-C	CH2-D	CH14-A	CH14-B	CH14-C	CH14-D
		CH1-A	CH1-B	CH1-C	CH1-D	CH16-A	CH16-B	CH16-C	CH16-D
042h	RS3	CH3-A	CH3-B	CH3-C	CH3-D	CH15-A	CH15-B	CH15-C	CH15-D
		CH2-A	CH2-B	CH2-C	CH2-D	CH17-A	CH17-B	CH17-C	CH17-D
043h	RS4	CH4-A	CH4-B	CH4-C	CH4-D	CH16-A	CH16-B	CH16-C	CH16-D
		CH3-A	CH3-B	CH3-C	CH3-D	CH18-A	CH18-B	CH18-C	CH18-D
044h	RS5	CH5-A	CH5-B	CH5-C	CH5-D	CH17-A	CH17-B	CH17-C	CH17-D
		CH4-A	CH4-B	CH4-C	CH4-D	CH19-A	CH19-B	CH19-C	CH19-D
045h	RS6	CH6-A	CH6-B	CH6-C	CH6-D	CH18-A	CH18-B	CH18-C	CH18-D
		CH5-A	CH5-B	CH5-C	CH5-D	CH20-A	CH20-B	CH20-C	CH20-D
046h	RS7	CH7-A	CH7-B	CH7-C	CH7-D	CH19-A	CH19-B	CH19-C	CH19-D
		CH6-A	CH6-B	CH6-C	CH6-D	CH21-A	CH21-B	CH21-C	CH21-D
047h	RS8	CH8-A	CH8-B	CH8-C	CH8-D	CH20-A	CH20-B	CH20-C	CH20-D
		CH7-A	CH7-B	CH7-C	CH7-D	CH22-A	CH22-B	CH22-C	CH22-D
048h	RS9	CH9-A	CH9-B	CH9-C	CH9-D	CH21-A	CH21-B	CH21-C	CH21-D
		CH8-A	CH8-B	CH8-C	CH8-D	CH23-A	CH23-B	CH23-C	CH23-D
049h	RS10	CH10-A	CH10-B	CH10-C	CH10-D	CH22-A	CH22-B	CH22-C	CH22-D
		CH9-A	CH9-B	CH9-C	CH9-D	CH24-A	CH24-B	CH24-C	CH24-D
04Ah	RS11	CH11-A	CH11-B	CH11-C	CH11-D	CH23-A	CH23-B	CH23-C	CH23-D
		CH10-A	CH10-B	CH10-C	CH10-D	CH25-A	CH25-B	CH25-C	CH25-D
04Bh	RS12	CH12-A	CH12-B	CH12-C	CH12-D	CH24-A	CH24-B	CH24-C	CH24-D
		CH11-A	CH11-B	CH11-C	CH11-D	CH26-A	CH26-B	CH26-C	CH26-D
04Ch	RS13	—	—	—	—	—	—	—	—
		CH12-A	CH12-B	CH12-C	CH12-D	CH27-A	CH27-B	CH27-C	CH27-D
04Dh	RS14	—	—	—	—	—	—	—	—
		CH13-A	CH13-B	CH13-C	CH13-D	CH28-A	CH28-B	CH28-C	CH28-D
04Eh	RS15	—	—	—	—	—	—	—	—
		CH14-A	CH14-B	CH14-C	CH14-D	CH29-A	CH29-B	CH29-C	CH29-D
04Fh	RS16	—	—	—	—	—	—	—	—
		CH15-A	CH15-B	CH15-C	CH15-D	CH30-A	CH30-B	CH30-C	CH30-D
050h	LCVCR1	LCVC15	LCVC14	LCVC13	LCVC12	LCVC11	LCVC10	LCVC9	LCCV8
051h	LCVCR2	LCVC7	LCVC6	LCVC5	LCVC4	LCVC3	LCVC2	LCVC1	LCVC0
052h	PCVCR1	PCVC15	PCVC14	PCVC13	PCVC12	PCVC11	PCVC10	PCVC9	PCVC8
053h	PCVCR2	PCVC7	PCVC6	PCVC5	PCVC4	PCVC3	PCVC2	PCVC1	PCVC0
054h	FOSCR1	FOS15	FOS14	FOS13	FOS12	FOS11	FOS10	FOS9	FOS8
055h	FOSCR2	FOS7	FOS6	FOS5	FOS4	FOS3	FOS2	FOS1	FOS0

ADDR	NAME	BIT 7	BIT 6	BIT 5	BIT 4	BIT 3	BIT 2	BIT 1	BIT 0
056h	E1EBCR1	EB15	EB14	EB13	EB12	EB11	EB10	EB9	EB8
057h	E1EBCR2	EB7	EB6	EB5	EB4	EB3	EB2	EB1	EB0
060h	RDS0M	B1	B2	B3	B4	B5	B6	B7	B8
061h	—	—	—	—	—	—	—	—	—
062h	T1RFDL	RFDL7	RFDL6	RFDL5	RFDL4	RFDL3	RFDL2	RFDL1	RFDL0
	E1RRTS7	CSC5	CSC4	CSC3	CSC2	CSC0	CRC4SA	CASSA	FASSA
063h	T1RBOC	—	—	RBOC5	RBOC4	RBOC3	RBOC2	RBOC1	RBOC0
064h	T1RSLC1	C8	C7	C6	C5	C4	C3	C2	C1
	E1RAF	Si	0	0	1	1	0	1	1
065h	T1RSLC2	M2	M1	S=0	S=1	S=0	C11	C10	C9
	E1RNAF	Si	1	A	Sa4	Sa5	Sa6	Sa7	Sa8
066h	T1RSLC3	S=1	S4	S3	S2	S1	A2	A1	M3
	E1RSiAF	SiF14	SiF12	SiF10	SiF8	SiF6	SiF4	SiF2	SiF0
067h	E1RSiNAF	SiF15	SiF13	SiF11	SiF9	SiF7	SiF5	SiF3	SiF1
068h	E1RRA	RRAF15	RRAF13	RRAF11	RRAF9	RRAF7	RRAF5	RRAF3	RRAF1
069h	E1RSa4	RSa4F15	RSa4F13	RSa4F11	RSa4F9	RSa4F7	RSa4F5	RSa4F3	RSa4F1
06Ah	E1RSa5	RSa5F15	RSa5F13	RSa5F11	RSa5F9	RSa5F7	RSa5F5	RSa5F3	RSa5F1
06Bh	E1RSa6	RSa6F15	RSa6F13	RSa6F11	RSa6F9	RSa6F7	RSa6F5	RSa6F3	RSa6F1
06Ch	E1RSa7	RSa7F15	RSa7F13	RSa7F11	RSa7F9	RSa7F7	RSa7F5	RSa7F3	RSa7F1
06Dh	E1RSa8	RSa8F15	RSa8F13	RSa8F11	RSa8F9	RSa8F7	RSa8F5	RSa8F3	RSa8F1
06Eh	SaBITS	—	—	—	Sa4	Sa5	Sa6	Sa7	Sa8
06Fh	Sa6CODE	—	—	—	—	Sa6n	Sa6n	Sa6n	Sa6n
080h	RMMR	FRM_EN	INIT_DONE	—	—	—	—	SFTRST	T1/E1
081h	RCR1 (T1)	SYNCT	RB8ZS	RFM	ARC	SYNCC	RJC	SYNCE	RESYNC
	RCR1 (E1)	—	RHDB3	RSIGM	RG802	RCRC4	FRC	SYNCE	RESYNC
082h	T1RIBCC	—	—	RUP2	RUP1	RUP0	RDN2	RDN1	RDN0
	E1RCR2	RSa8S	RSa7S	RSa6S	RSa5S	RSa4S	—	—	RLOSA
083h	RCR3	IDF	—	RSERC	—	—	—	PLB	FLB
084h	RIOCR	RCLKINV	RSYNCLINV	H100EN	RSCLKM	RSMS	RSIO	RSMS2	RSMS1
		RCLKINV	RSYNCLINV	H100EN	RSCLKM	—	RSIO	RSMS2	RSMS1
085h	RESCR	RDATFMT	RGCLKEN	—	RSZS	RESALGN	RESR	RESMDM	RESE
086h	ERCNT	1SECS	MCUS	MECU	ECUS	EAMS	FSBE	MOSCRF	LCVCRF
		1SECS	MCUS	MECU	ECUS	EAMS	—	—	LCVCRF
087h	RHFC	—	—	—	—	—	—	RFHWM1	RFHWM0
088h	RIBOC	—	IBS1	IBS0	IBOSEL	IBOEN	DA2	DA1	DA0
089h	T1RSCC	—	—	—	—	—	RSC2	RSC1	RSC0
08Ah	RXPC	—	—	—	—	—	RBPDIR	RBPDIR	RBPEN
		—	—	—	—	—	RBPDIR	—	RBPEN
08Bh	RBPBS	BPBSE8	BPBSE7	BPBSE6	BPBSE5	BPBSE4	BPBSE3	BPBSE2	BPBSE1
090h	RLS1	RRAIC	RAISC	RLOSC	RLOFC	RRAID	RAISD	RLOSD	RLOFD
091h	RLS2 (T1)	RPDV	—	COFA	8ZD	16ZD	SEFE	B8ZS	FBE
	RLS2 (E1)	—	CRCRC	CASRC	FASRC	RSA1	RSA0	RCMF	RAF
092h	RLS3 (T1)	LORCC	LSPC	LDNC	LUPC	LORCD	LSPD	LDND	LUPD
	RLS3 (E1)	LORCC	—	V52LNKC	RDMAC	LORCD	—	V52LNKD	RDMAD
093h	RLS4	RESF	RESEM	RSLIP	—	RSCOS	1SEC	TIMER	RMF
094h	RLS5	—	—	ROVR	RHOBT	RPE	RPS	RHWMS	RNES
096h	RLS7 (T1)	—	—	RRAI-CI	RAIS-CI	RSLC96	RFDLF	BC	BD
	RLS7 (E1)	—	—	—	—	—	—	Sa6CD	SaXCD

ADDR	NAME	BIT 7	BIT 6	BIT 5	BIT 4	BIT 3	BIT 2	BIT 1	BIT 0
097h	—	—	—	—	—	—	—	—	—
098h	RSS1	CH8	CH7	CH6	CH5	CH4	CH3	CH2	CH1
099h	RSS2	CH16	CH15	CH14	CH13	CH12	CH11	CH10	CH9
09Ah	RSS3	CH24	CH23	CH22	CH21	CH20	CH19	CH18	CH17
09Bh	RSS4	—	—	—	—	—	—	—	—
		<i>CH32</i>	<i>CH31</i>	<i>CH30</i>	<i>CH29</i>	<i>CH28</i>	<i>CH27</i>	<i>CH26</i>	<i>CH25</i>
09Ch	T1RSCD1	C7	C6	C5	C4	C3	C2	C1	C0
		—	—	—	—	—	—	—	—
09Dh	T1RSCD2	C7	C6	C5	C4	C3	C2	C1	C0
		—	—	—	—	—	—	—	—
09Fh	RIIR	—	RLS7	RLS6*	RLS5	RLS4	RLS3	RLS2**	RLS1
0A0h	RIM1	RRAIC	RAISC	RLOSC	RLOFC	RRAID	RAISD	RLOSD	RLOFD
0A1h	RIM2	—	—	—	—	—	—	—	—
		—	—	—	—	<i>RSA1</i>	<i>RSA0</i>	<i>RCMF</i>	<i>RAF</i>
0A2h	RIM3 (T1)	LORCC	LSPC	LDNC	LUPC	LORCD	LSPD	LDND	LUPD
	RIM3 (E1)	<i>LORCC</i>	—	<i>V52LNKC</i>	<i>RDMAC</i>	<i>LORCD</i>	—	<i>V52LNKD</i>	<i>RDMAD</i>
0A3h	RIM4	RESF	RESEM	RSLIP	—	RSCOS	1SEC	TIMER	RMF
0A4h	RIM5	—	—	ROVR	RHOBT	RPE	RPS	RHWMS	RNES
0A6h	RIM7 (T1)	—	—	RRAI-CI	RAIS-CI	RSLC96	RFDLF	BC	BD
	RIM7 (E1)	—	—	—	—	—	—	<i>Sa6CD</i>	<i>SaXCD</i>
0A8h	RSCSE1	CH8	CH7	CH6	CH5	CH4	CH3	CH2	CH1
0A9h	RSCSE2	CH16	CH15	CH14	CH13	CH12	CH11	CH10	CH9
0AAh	RSCSE3	CH24	CH23	CH22	CH21	CH20	CH19	CH18	CH17
0Abh	RSCSE4	—	—	—	—	—	—	—	—
		<i>CH32</i>	<i>CH31</i>	<i>CH30</i>	<i>CH29</i>	<i>CH28</i>	<i>CH27</i>	<i>CH26</i>	<i>CH25</i>
0ACh	T1RUPCD1	C7	C6	C5	C4	C3	C2	C1	C0
		—	—	—	—	—	—	—	—
0ADh	T1RUPCD2	C7	C6	C5	C4	C3	C2	C1	C0
		—	—	—	—	—	—	—	—
0AEh	T1RDNCD1	C7	C6	C5	C4	C3	C2	C1	C0
		—	—	—	—	—	—	—	—
0AFh	T1RDNCD2	C7	C6	C5	C4	C3	C2	C1	C0
		—	—	—	—	—	—	—	—
0B0h	RRTS1	—	—	—	—	RRAI	RAIS	RLOS	RLOF
0B2h	RRTS3 (T1)	—	—	—	—	LORC	LSP	LDN	LUP
	RRTS3 (E1)	—	—	—	—	<i>LORC</i>	—	<i>V52LNK</i>	<i>RDMA</i>
0B4h	RRTS5	—	PS2	PS1	PS0	—	—	RHWM	RNE
0B5h	RHPBA	MS	RPBA6	RPBA5	RPBA4	RPBA3	RPBA2	RPBA1	RPBA0
0B6h	RHE	RHD7	RHD6	RHD5	RHD4	RHD3	RHD2	RHD1	RHD0
0C0h	RBCS1	CH8	CH7	CH6	CH5	CH4	CH3	CH2	CH1
0C1h	RBCS2	CH16	CH15	CH14	CH13	CH12	CH11	CH10	CH9
0C2h	RBCS3	CH24	CH23	CH22	CH21	CH20	CH19	CH18	CH17
0C3h	RBCS4	—	—	—	—	—	—	—	—
		<i>CH32</i>	<i>CH31</i>	<i>CH30</i>	<i>CH29</i>	<i>CH28</i>	<i>CH27</i>	<i>CH26</i>	<i>CH25</i>
0C4h	RCBR1	CH8	CH7	CH6	CH5	CH4	CH3	CH2	CH1
0C5h	RCBR2	CH16	CH15	CH14	CH13	CH12	CH11	CH10	CH9
0C6h	RCBR3	CH24	CH23	CH22	CH21	CH20	CH19	CH18	CH17
0C7h	RCBR4	—	—	—	—	—	—	—	—
		<i>CH32</i>	<i>CH31</i>	<i>CH30</i>	<i>CH29</i>	<i>CH28</i>	<i>CH27</i>	<i>CH26</i>	<i>CH25(F-bit)</i>
0C8h	RS11	CH8	CH7	CH6	CH5	CH4	CH3	CH2	CH1

ADDR	NAME	BIT 7	BIT 6	BIT 5	BIT 4	BIT 3	BIT 2	BIT 1	BIT 0
0C9h	RSI2	CH16	CH15	CH14	CH13	CH12	CH11	CH10	CH9
0CAh	RSI3	CH24	CH23	CH22	CH21	CH200	CH19	CH18	CH17
0CBh	RSI4	—	—	—	—	—	—	—	—
		<i>CH32</i>	<i>CH31</i>	<i>CH30</i>	<i>CH29</i>	<i>CH28</i>	<i>CH27</i>	<i>CH26</i>	<i>CH25</i>
0CCh	RGCCS1	CH8	CH7	CH6	CH5	CH4	CH3	CH2	CH1
0CDh	RGCCS2	CH16	CH15	CH14	CH13	CH12	CH11	CH10	CH9
0CEh	RGCCS3	CH24	CH23	CH22	CH21	CH20	CH19	CH18	CH17
0CFh	RGCCS4	—	—	—	—	—	—	—	—
		<i>CH32</i>	<i>CH31</i>	<i>CH30</i>	<i>CH29</i>	<i>CH28</i>	<i>CH27</i>	<i>CH26</i>	<i>CH25(F-bit)</i>
0D0h	RCICE1	CH8	CH7	CH6	CH5	CH4	CH3	CH2	CH1
0D1h	RCICE2	CH16	CH15	CH14	CH13	CH12	CH11	CH10	CH9
0D2h	RCICE3	CH24	CH23	CH22	CH21	CH20	CH19	CH18	CH17
0D3h	RCICE4	—	—	—	—	—	—	—	—
		<i>CH32</i>	<i>CH31</i>	<i>CH30</i>	<i>CH29</i>	<i>CH28</i>	<i>CH27</i>	<i>CH26</i>	<i>CH25</i>
0D4h	RBPCS1	CH8	CH7	CH6	CH5	CH4	CH3	CH2	CH1
0D5h	RBPCS2	CH16	CH15	CH14	CH13	CH12	CH11	CH10	CH9
0D6h	RBPCS3	CH24	CH23	CH22	CH21	CH20	CH19	CH18	CH17
0D7h	RBPCS4	—	—	—	—	—	—	—	—
		<i>CH32</i>	<i>CH31</i>	<i>CH30</i>	<i>CH29</i>	<i>CH28</i>	<i>CH27</i>	<i>CH26</i>	<i>CH25</i>
110h	THC1	NOFS	TEOML	THR	THMS	TFS	TEOM	TZSD	TCRCD
111h	THBSE	TBSE8	TBSE7	TBSE6	TBSE5	TBSE4	TBSE3	TBSE2	TBSE1
113h	THC2	TABT	SBOC	THCEN	THCS4	THCS3	THCS2	THCS1	THCS0
		<i>TABT</i>	—	<i>THCEN</i>	<i>THCS4</i>	<i>THCS3</i>	<i>THCS2</i>	<i>THCS1</i>	<i>THCS0</i>
118h	SSIE1	CH8	CH7	CH6	CH5	CH4	CH3	CH2	CH1
119h	SSIE2	CH16	CH15	CH14	CH13	CH12	CH11	CH10	CH9
11Ah	SSIE3	CH24	CH23	CH22	CH21	CH20	CH19	CH18	CH17
11Bh	SSIE4	—	—	—	—	—	—	—	—
		<i>CH32</i>	<i>CH31</i>	<i>CH30</i>	<i>CH29</i>	<i>CH28</i>	<i>CH27</i>	<i>CH26</i>	<i>CH25</i>
120h	TIDR1	C7	C6	C5	C4	C3	C2	C1	C0
121h	TIDR2	C7	C6	C5	C4	C3	C2	C1	C0
122h	TIDR3	C7	C6	C5	C4	C3	C2	C1	C0
123h	TIDR4	C7	C6	C5	C4	C3	C2	C1	C0
124h	TIDR5	C7	C6	C5	C4	C3	C2	C1	C0
125h	TIDR6	C7	C6	C5	C4	C3	C2	C1	C0
126h	TIDR7	C7	C6	C5	C4	C3	C2	C1	C0
127h	TIDR8	C7	C6	C5	C4	C3	C2	C1	C0
128h	TIDR9	C7	C6	C5	C4	C3	C2	C1	C0
129h	TIDR10	C7	C6	C5	C4	C3	C2	C1	C0
12Ah	TIDR11	C7	C6	C5	C4	C3	C2	C1	C0
12Bh	TIDR12	C7	C6	C5	C4	C3	C2	C1	C0
12Ch	TIDR13	C7	C6	C5	C4	C3	C2	C1	C0
12Dh	TIDR14	C7	C6	C5	C4	C3	C2	C1	C0
12Eh	TIDR15	C7	C6	C5	C4	C3	C2	C1	C0
12Fh	TIDR16	C7	C6	C5	C4	C3	C2	C1	C0
130h	TIDR17	C7	C6	C5	C4	C3	C2	C1	C0
131h	TIDR18	C7	C6	C5	C4	C3	C2	C1	C0
132h	TIDR19	C7	C6	C5	C4	C3	C2	C1	C0
133h	TIDR20	C7	C6	C5	C4	C3	C2	C1	C0
134h	TIDR21	C7	C6	C5	C4	C3	C2	C1	C0

ADDR	NAME	BIT 7	BIT 6	BIT 5	BIT 4	BIT 3	BIT 2	BIT 1	BIT 0
135h	TIDR22	C7	C6	C5	C4	C3	C2	C1	C0
136h	TIDR23	C7	C6	C5	C4	C3	C2	C1	C0
137h	TIDR24	C7	C6	C5	C4	C3	C2	C1	C0
138h	TIDR25	—	—	—	—	—	—	—	—
		C7	C6	C5	C4	C3	C2	C1	C0
139h	TIDR26	—	—	—	—	—	—	—	—
		C7	C6	C5	C4	C3	C2	C1	C0
13Ah	TIDR27	—	—	—	—	—	—	—	—
		C7	C6	C5	C4	C3	C2	C1	C0
13Bh	TIDR28	—	—	—	—	—	—	—	—
		C7	C6	C5	C4	C3	C2	C1	C0
13Ch	TIDR29	—	—	—	—	—	—	—	—
		C7	C6	C5	C4	C3	C2	C1	C0
13Dh	TIDR30	—	—	—	—	—	—	—	—
		C7	C6	C5	C4	C3	C2	C1	C0
13Eh	TIDR31	—	—	—	—	—	—	—	—
		C7	C6	C5	C4	C3	C2	C1	C0
13Fh	TIDR32	—	—	—	—	—	—	—	—
		C7	C6	C5	C4	C3	C2	C1	C0
140h	TS1	CH1-A	CH1-B	CH1-C	CH1-D	CH13-A	CH13-B	CH13-C	CH13-D
		0	0	0	0	X	Y	X	X
141h	TS2	CH2-A	CH2-B	CH2-C	CH2-D	CH14-A	CH14-B	CH14-C	CH14-D
		CH1-A	CH1-B	CH1-C	CH1-D	CH16-A	CH16-B	CH16-C	CH16-D
142h	TS3	CH3-A	CH3-B	CH3-C	CH3-D	CH15-A	CH15-B	CH15-C	CH15-D
		CH2-A	CH2-B	CH2-C	CH2-D	CH17-A	CH17-B	CH17-C	CH17-D
143h	TS4	CH4-A	CH4-B	CH4-C	CH4-D	CH16-A	CH16-B	CH16-C	CH16-D
		CH3-A	CH3-B	CH3-C	CH3-D	CH18-A	CH18-B	CH18-C	CH18-D
144h	TS5	CH5-A	CH5-B	CH5-C	CH5-D	CH17-A	CH17-B	CH17-C	CH17-D
		CH4-A	CH4-B	CH4-C	CH4-D	CH19-A	CH19-B	CH19-C	CH19-D
145h	TS6	CH6-A	CH6-B	CH6-C	CH6-D	CH18-A	CH18-B	CH18-C	CH18-D
		CH5-A	CH5-B	CH5-C	CH5-D	CH20-A	CH20-B	CH20-C	CH20-D
146h	TS7	CH7-A	CH7-B	CH7-C	CH7-D	CH19-A	CH19-B	CH19-C	CH19-D
		CH6-A	CH6-B	CH6-C	CH6-D	CH21-A	CH21-B	CH21-C	CH21-D
147h	TS8	CH8-A	CH8-B	CH8-C	CH8-D	CH20-A	CH20-B	CH20-C	CH20-D
		CH7-A	CH7-B	CH7-C	CH7-D	CH22-A	CH22-B	CH22-C	CH22-D
148h	TS9	CH9-A	CH9-B	CH9-C	CH9-D	CH21-A	CH21-B	CH21-C	CH21-D
		CH8-A	CH8-B	CH8-C	CH8-D	CH23-A	CH23-B	CH23-C	CH23-D
149h	TS10	CH10-A	CH10-B	CH10-C	CH10-D	CH22-A	CH22-B	CH22-C	CH22-D
		CH9-A	CH9-B	CH9-C	CH9-D	CH24-A	CH24-B	CH24-C	CH24-D
14Ah	TS11	CH11-A	CH11-B	CH11-C	CH11-D	CH23-A	CH23-B	CH23-C	CH23-D
		CH10-A	CH10-B	CH10-C	CH10-D	CH25-A	CH25-B	CH25-C	CH25-D
14Bh	TS12	CH12-A	CH12-B	CH12-C	CH12-D	CH24-A	CH24-B	CH24-C	CH24-D
		CH11-A	CH11-B	CH11-C	CH11-D	CH26-A	CH26-B	CH26-C	CH26-D
14Ch	TS13	—	—	—	—	—	—	—	—
		CH12-A	CH12-B	CH12-C	CH12-D	CH27-A	CH27-B	CH27-C	CH27-D
14Dh	TS14	—	—	—	—	—	—	—	—
		CH13-A	CH13-B	CH13-C	CH13-D	CH28-A	CH28-B	CH28-C	CH28-D

ADDR	NAME	BIT 7	BIT 6	BIT 5	BIT 4	BIT 3	BIT 2	BIT 1	BIT 0
14Eh	TS15	—	—	—	—	—	—	—	—
		CH14-A	CH14-B	CH14-C	CH14-D	CH29-A	CH29-B	CH29-C	CH29-D
14Fh	TS16	—	—	—	—	—	—	—	—
		CH15-A	CH15-B	CH15-C	CH15-D	CH30-A	CH30-B	CH30-C	CH30-D
150h	TCICE1	CH8	CH7	CH6	CH5	CH4	CH3	CH2	CH1
151h	TCICE2	CH16	CH15	CH14	CH13	CH12	CH11	CH10	CH9
152h	TCICE3	CH24	CH23	CH22	CH21	CH20	CH19	CH18	CH17
153h	TCICE4	—	—	—	—	—	—	—	—
		CH32	CH31	CH30	CH29	CH28	CH27	CH26	CH25
162h	T1TFDL	TFDL7	TFDL6	TFDL5	TFDL4	TFDL3	TFDL2	TFDL1	TFDL0
		—	—	—	—	—	—	—	—
163h	T1TBOC	—	—	TBOC5	TBOC4	TBOC3	TBOC2	TBOC1	TBOC0
		—	—	—	—	—	—	—	—
164h	T1TSLC1 E1TAF	C8	C7	C6	C5	C4	C3	C2	C1
		Si	0	0	1	1	0	1	1
165h	T1TSLC2 E1TNAF	M2	M1	S=0	S=1	S=0	C11	C10	C9
		Si	1	A	Sa4	Sa5	Sa6	Sa7	Sa8
166h	T1TSLC3 E1TSiAF	S=1	S4	S3	S2	S1	A2	A1	M3
		TSiF14	TSiF12	TSiF10	TSiF8	TSiF6	TSiF4	TSiF2	TSiF0
167h	E1TSiNAF	—	—	—	—	—	—	—	—
		TsiF15	TSiF13	TSiF11	TSiF9	TSiF7	TSiF5	TSiF3	TSiF1
168h	E1TRA	—	—	—	—	—	—	—	—
		TRAF15	TRAF13	TRAF11	TRAF9	TRAF7	TRAF5	TRAF3	TRAF1
169h	E1TSa4	—	—	—	—	—	—	—	—
		TSa4F15	TSa4F13	TSa4F11	TSa4F9	TSa4F7	TSa4F5	TSa4F3	TSa4F1
16Ah	E1TSa5	—	—	—	—	—	—	—	—
		TSa5F15	TSa5F13	TSa5F11	TSa5F9	TSa5F7	TSa5F5	TSa5F3	TSa5F1
16Bh	E1TSa6	—	—	—	—	—	—	—	—
		TSa6F15	TSa6F13	TSa6F11	TSa6F9	TSa6F7	TSa6F5	TSa6F3	TSa6F1
16Ch	E1TSa7	—	—	—	—	—	—	—	—
		TSa7F15	TSa7F13	TSa7F11	TSa7F9	TSa7F7	TSa7F5	TSa7F3	TSa7F1
16Dh	E1TSa8	—	—	—	—	—	—	—	—
		TSa8F15	TSa8F13	TSa8F11	TSa8F9	TSa8F7	TSa8F5	TSa8F3	TSa8F1
180h	IMMR	FRM_EN	INIT_DONE	—	—	—	—	SFTRST	T1/E1
181h	TCR1 (T1) TCR1 (E1)	TJC	TFPT	TCPT	TSSE	GB7S	TB8ZS	TAIS	TRAI
		TTPPT	T16S	TG802	TSiS	TSA1	THDB3	TAIS	TCRC4
182h	TCR2 (T1) TCR2 (E1)	TFDLS	TSLC96	—	FBCT2	FBCT1	TD4RM	PDE	TB7ZS
		AEBE	AAIS	ARA	Sa4S	Sa5S	Sa6S	Sa7S	Sa8S
183h	TCR3	ODF	ODM	TCSS1	TCSS0	MFRS	TFM	IBPV	TLOOP
		ODF	ODM	TCSS1	TCSS0	MFRS	—	IBPV	CRC4R
184h	TIOCR	TCLKINV	TSYNCINV	TSSYNCINV	TSCLKM	TSSM	TSIO	TSDW	TSM
		TCLKINV	TSYNCINV	TSSYNCINV	TSCLKM	TSSM	TSIO	—	TSM
185h	TESCR	TDATFMT	TGCLKEN	—	TSZS	TESALGN	TESR	TESMDM	TESE
186h	TCR4	—	—	—	—	TRAIM	TAISM	TC1	TC0
		—	—	—	—	—	—	—	—
187h	THFC	—	—	—	—	—	—	TFLWM1	TFLWM2
188h	TIBOC	—	IBS1	IBS0	IBOSEL	IBOEN	DA2	DA1	DA0
189h	TDS0SEL	—	—	—	TCM4	TCM3	TCM2	TCM1	TCM0

ADDR	NAME	BIT 7	BIT 6	BIT 5	BIT 4	BIT 3	BIT 2	BIT 1	BIT 0
18Ah	TXPC	—	—	—	—	—	TBPDIR	TBPFUS	TBPEN
18Bh	TBPBS	BPBSE8	BPBSE7	BPBSE6	BPBSE5	BPBSE4	BPBSE3	BPBSE2	BPBSE1
18Eh	TSYNCC	—	—	—	—	—	TSEN	SYNCE	RESYNC
		—	—	—	—	CRC4	TSEN	SYNCE	RESYNC
190h	TLS1	TESF	TESEM	TSLIP	TSLC96	TPDV	TMF	LOTCC	LOTC
		TESF	TESEM	TSLIP	—	TAF	TMF	LOTCC	LOTC
191h	TLS2	—	—	—	TFDLE	TUDR	TMEND	TLWMS	TNFS
		—	—	—	—	TUDR	TMEND	TLWMS	TNFS
192h	TLS3	—	—	—	—	—	—	LOF	LOFD
19Fh	TIIR	—	—	—	—	—	TLS3	TLS2	TLS1
1A0h	TIM1	TESF	TESEM	TSLIP	TSLC96	TPDV	TMF	LOTCC	LOTC
		TESF	TESEM	TSLIP	—	TAF	TMF	LOTCC	LOTC
1A1h	TIM2	—	—	—	TFDLE	TUDR	TMEND	TLWMS	TNFS
		—	—	—	—	TUDR	TMEND	TLWMS	TNFS
1A2h	TIM3	—	—	—	—	—	—	—	LOFD
1ACh	T1TCD1	C7	C6	C5	C4	C3	C2	C1	C0
		—	—	—	—	—	—	—	—
ADh	T1TCD2	C7	C6	C5	C4	C3	C2	C1	C0
		—	—	—	—	—	—	—	—
1B1h	TRTS2	—	—	—	—	EMPTY	TFULL	TLWMS	TNF
1B3h	TFBA	—	TFBA6	TFBA5	TFBA4	TFBA3	TFBA2	TFBA1	TFBA0
1B4h	THE	THD7	THD6	THD5	THD4	THD3	THD2	THD1	THD0
1BBh	TDSOM	B1	B2	B3	B4	B5	B6	B7	B8
1C0h	TBCS1	CH8	CH7	CH6	CH5	CH4	CH3	CH2	CH1
1C1h	TBCS2	CH16	CH15	CH14	CH13	CH12	CH11	CH10	CH9
1C2h	TBCS3	CH24	CH23	CH22	CH21	CH20	CH19	CH18	CH17
1C3h	TBCS4	—	—	—	—	—	—	—	—
		CH32	CH31	CH30	CH29	CH28	CH27	CH26	CH25
1C4h	TCBR1	CH8	CH7	CH6	CH5	CH4	CH3	CH2	CH1
1C5h	TCBR2	CH16	CH15	CH14	CH13	CH12	CH11	CH10	CH9
1C6h	TCBR3	CH24	CH23	CH22	CH21	CH20	CH19	CH18	CH17
1C7h	TCBR4	—	—	—	—	—	—	—	—
		CH32	CH31	CH30	CH29	CH28	CH27	CH26	CH25:Fbit
1C8h	THSCS1	CH8	CH7	CH6	CH5	CH4	CH3	CH2	CH1
1C9h	THSCS2	CH16	CH15	CH14	CH13	CH12	CH11	CH10	CH9
1CAh	THSCS3	CH24	CH23	CH22	CH21	CH20	CH19	CH18	CH17
1CBh	THSCS4	—	—	—	—	—	—	—	—
		CH32	CH31	CH30	CH29	CH28	CH27	CH26	CH25
1CCh	TGCCS1	CH8	CH7	CH6	CH5	CH4	CH3	CH2	CH1
1CDh	TGCCS2	CH16	CH15	CH14	CH13	CH12	CH11	CH10	CH9
1CEh	TGCCS3	CH24	CH23	CH22	CH21	CH20	CH19	CH18	CH17
1CFh	TGCCS4	—	—	—	—	—	—	—	—
		CH32	CH31	CH30	CH29	CH28	CH27	CH26	CH25(F-bit)
1D0h	PCL1	CH8	CH7	CH6	CH5	CH4	CH3	CH2	CH1
1D1h	PCL2	CH16	CH15	CH14	CH13	CH12	CH11	CH10	CH9
1D2h	PCL3	CH24	CH23	CH22	CH21	CH20	CH19	CH18	CH17
1D3h	PCL4	—	—	—	—	—	—	—	—
		CH32	CH31	CH30	CH29	CH28	CH27	CH26	CH25

ADDR	NAME	BIT 7	BIT 6	BIT 5	BIT 4	BIT 3	BIT 2	BIT 1	BIT 0
1D4h	TBPCS1	CH8	CH7	CH6	CH5	CH4	CH3	CH2	CH1
1D5h	TBPCS2	CH16	CH15	CH14	CH13	CH12	CH11	CH10	CH9
1D6h	TBPCS3	CH24	CH23	CH22	CH21	CH20	CH19	CH18	CH17
1D7h	TBPCS4	—	—	—	—	—	—	—	—
		CH32	CH31	CH30	CH29	CH28	CH27	CH26	CH25

*RLS6 is reserved for future use.

**Currently, RLS2 does not create an interrupt, therefore this bit is not used in T1 mode.

9.2.3 LIU Register Bit Map

Table 9-8. LIU Register Bit Map

ADDR	NAME	BIT 7	BIT 6	BIT 5	BIT 4	BIT 3	BIT 2	BIT 1	BIT 0
1000h	LTRCR	—	—	—	JADS	JAPS1	JAPS0	T1J1E1S	LSC
1001h	LTISR	—	TIMPTOFF	TIMPL1	TIMPL0	—	L2	L1	L0
1002h	LMCR	TAIS	ATAIS	LLB	ALB	RLB	TPDE	RPDE	TE
1003h	LRSR	—	—	OEQ	UEQ	—	SCS	OCS	LOSS
1004h	LSIMR	JALTCIM	OCCIM	SCCIM	LOSCIM	JALTSIM	OCDIM	SCDIM	LOSDIM
1005h	LLSR	JALTC	OCC	SCC	LOSC	JALTS	OCD	SCD	LOSD
1006h	LRSL	RSL3	RSL2	RLS1	RLS0	—	—	—	—
1007h	LRISMR	RG703	RIMPOFF	RIMPM1	RIMPM0	RTR	RMONEN	RSMS1	RSMS0

9.2.4 BERT Register Bit Map

Table 9-9. BERT Register Bit Map

ADDR	NAME	BIT 7	BIT 6	BIT 5	BIT 4	BIT 3	BIT 2	BIT 1	BIT 0
1100h	BAWC	ACNT7	ACNT6	ACNT5	ACNT4	ACNT3	ACNT2	ACNT1	ACNT0
1101h	BRP1	RPAT7	RPAT6	RPAT5	RPAT4	RPAT3	RPAT2	RPAT1	RPAT0
1102h	BRP2	RPAT15	RPAT14	RPAT13	RPAT12	RPAT11	RPAT10	RPAT9	RPAT8
1103h	BRP3	RPAT23	RPAT22	RPAT21	RPAT20	RPAT19	RPAT18	RPAT17	RPAT16
1104h	BRP4	RPAT31	RPAT30	RPAT29	RPAT28	RPAT27	RPAT26	RPAT25	RPAT24
1105h	BC1	TC	TINV	RINV	PS2	PS1	PS0	LC	RESYNC
1106h	BC2	EIB2	EIB1	EIB0	SBE	RPL3	RPL2	RPL1	RPL0
1107h	BBC1	BBC7	BBC6	BBC5	BBC4	BBC3	BBC2	BBC1	BBC0
1108h	BBC2	BBC15	BBC14	BBC13	BBC12	BBC11	BBC10	BBC9	BBC8
1109h	BBC3	BBC23	BBC22	BBC21	BBC20	BBC19	BBC18	BBC17	BBC16
110Ah	BBC4	BBC31	BBC30	BBC29	BBC28	BBC27	BBC26	BBC25	BBC24
110Bh	BEC1	EC7	EC6	EC5	EC4	EC3	EC2	EC1	EC0
110Ch	BEC2	EC15	EC14	EC13	EC12	EC11	EC10	EC9	EC8
110Dh	BEC3	EC23	EC22	EC21	EC20	EC19	EC18	EC17	EC16
110Eh	BLSR	—	BBED	BBCO	BECO	BRA1	BRA0	BRLOS	BSYNC
110Fh	BSIM	—	BBED	BBCO	BECO	BRA1	BRA0	BRLOS	BSYNC

9.3 Global Register Definitions

Functions contained in the global registers include: framer reset, LIU reset, device ID, BERT interrupt status, framer interrupt status, IBO configuration, MCLK configuration, and BPCLK configuration. The global registers bit descriptions are presented in this section.

Table 9-10. Global Register Set

ADDRESS	NAME	DESCRIPTION	R/W
0F0h	GTCR1	Global Transceiver Control Register 1	R/W
0F1h	GFCR	Global Framer Control Register	R/W
0F2h	GTCR2	Global Transceiver Control Register 2	R/W
0F3h	GTCCR	Global Transceiver Clock Control Register	R/W
0F4h	—	Reserved	—
0F5h	GLSRR	Global LIU Software Reset Register	R/W
0F6h	GFSRR	Global Framer and BERT Software Reset Register	R/W
0F7h	—	Reserved	—
0F8h	IDR	Device Identification Register	R
0F9h	GFISR	Global Framer Interrupt Status Register	R
0FAh	GBISR	Global BERT Interrupt Status Register	R
0FBh	GLISR	Global LIU Interrupt Status Register	R
0FCh	GFIMR	Global Framers Interrupt Mask Register	R/W
0FDh	GBIMR	Global BERT Interrupt Mask Register	R/W
0FEh	GLIMR	Global LIU Interrupt Mask Register	R/W
01Fh	—	Reserved	—

Note 1: Reserved registers should only be written with all zeros.

Note 2: The global registers are located in the framer address space. The corresponding address space for the other seven framers is "Reserved," and should be initialized with all zeros for proper operation.

Register Name **GTCR1**
 Register Description: **Global Transceiver Control Register 1**
 Register Address: **0F0h**

Bit #	7	6	5	4	3	2	1	0
Name	—	—	RLOFLTS	GIBO	—	BWE	GCLE	GIPI
Default	0	0	0	0	0	0	0	0

Bit 5: Receive Loss of Frame/Loss of Transmit Clock Indication Select (RLOFLTS).

- 0 = RLOF/LTCx pin indicates framer receive loss of frame
- 1 = RLOF/LTCx pin indicates framer loss of transmit clock

Bit 4: Global IBO Enable (GIBO). This bit is used to select either the internal mux for IBO operation or an external wire-OR operation. Normally this bit should be set = 0 and the internal mux used.

- 0 = Use internal IBO mux
- 1 = Externally wire-OR TSERs and RSERs for IBO operation

Bit 2: Bulk Write Enable (BWE). When this bit is set, a port write to one of the quad ports is mapped into all four ports. This applies to the framer, BERT, and LIU register sets. It must be cleared before performing a read operation. This bit is useful for device initialization.

- 0 = Normal operation
- 1 = Bulk write is enabled

Bit 1: Global Counter Latch Enable (GCLE). A low-to-high transition on this bit will, when enabled, latch the framer performance monitor counters. Each framer can be independently enabled to accept this input. This bit must be cleared and set again to perform another counter latch.

Bit 0: Global Interrupt Pin Inhibit (GIPI).

- 0 = Normal operation. Interrupt pin ($\overline{\text{INTB}}$) will toggle low on an unmasked interrupt condition.
- 1 = Interrupt inhibit. Interrupt pin ($\overline{\text{INTB}}$) is forced high (inactive) when this bit is set.

Register Name: **GFCR**
 Description: **Global Framer Control Register**
 Register Address: **0F1h**

Bit #	7	6	5	4	3	2	1	0
Name	IBOMS1	IBOMS0	BPCLK1	BPCLK0	RFLOSSFS	RFMSS	TCBCS	RCBCS
Default	0	0	0	0	0	0	0	0

Bits 7 and 6: Interleave Bus Operation Mode Select 1 and 0 (IBOMS[1:0]). These bits determine the configuration of the IBO (interleaved bus) multiplexer. These bits should be used in conjunction with the Rx and Tx IBO control registers within each of the framer units. Additional information concerning the IBO multiplexer is given in Section [8.8.2](#).

IBOMS1	IBOMS0	IBO MODE
0	0	IBO multiplexer disabled
0	1	2 devices on bus (4.096MHz)
1	0	4 devices on bus (8.192MHz)
1	1	8 devices on bus (16.384MHz)

Bits 5 and 4: Backplane Clock Select 1 and 0 (BPCLK[1:0]). These bits determine the clock frequency output on the BPCLK pin.

BPCLK1	BPCLK0	BPCLK FREQUENCY
0	0	2.048MHz
0	1	4.096MHz
1	0	8.192MHz
1	1	16.384MHz

Bit 3: Receive Loss of Signal/Signaling Freeze Select (RLOSSFS). This bit controls the function of all four AL/RSIGF/FLOS pins. The receive LOS is further selected between framer LOS and LIU LOS by [GTCR2.2](#).

- 0 = AL/RSIGF/FLOS pin outputs RLOS[1:4] (receive loss)
- 1 = AL/RSIGF/FLOS pin outputs RSIGF[1:4] (receive-signaling freeze)

Bit 2: Receive Frame/Multiframe Sync Select (RFMSS). This bit controls the function of all four RMSYNC/RFSYNC pins.

- 0 = RMSYNC/RFSYNC pin outputs RFSYNC[1:4] (receive frame sync)
- 1 = RMSYNC/RFSYNC pin outputs RMSYNC[1:4] (receive multiframe sync)

Bit 1: Transmit Channel Block/Clock Select (TCBCS). This bit controls the function of all four TCHBLK/CLK pins.

- 0 = TCHBLK/CLK pin outputs TCHBLK[1:4] (transmit channel block)
- 1 = TCHBLK/CLK pin outputs TCHCLK[1:4] (transmit channel clock)

Bit 0: Receive Channel Block/Clock Select (RCBCS). This bit controls the function of all four RCHBLK/CLK pins.

- 0 = RCHBLK/CLK pin outputs RCHBLK[1:4] (receive channel block)
- 1 = RCHBLK/CLK pin outputs RCHCLK[1:4] (receive channel clock)

Register Name: **GTCR2**
 Register Description: **Global Transceiver Control Register 2**
 Register Address: **0F2h**

Bit #	7	6	5	4	3	2	1	0
Name	—	—	—	—	—	LOSS	TSSYNCEOSEL	—
Default	0	0	0	0	0	0	0	0

Bit 2: LOS Selection (LOSS). If this bit is set, the AL/RSIGF/FLOS pins can be driven with LIU loss. If reset, they are driven by framer LOS. The selection of whether to drive AL/RSIGF/FLOS pins with LOS (analog or digital) or signalling freeze is controlled by [GFCR.2](#). This selection affects all ports.

Bit 1: Transmit System Synchronization I/O Select (TSSYNCEOSEL). If this bit is set to a 1, the TSSYNCEO is an 8kHz output synchronous to the BPCLK. This “frame pulse” can be used in conjunction with the backplane clock to provide IBO signals for a system backplane. If this bit is reset, TSSYNCEO is an input. An 8kHz frame pulse is required for transmit synchronization and IBO operation.

Register Name: **GTCCR**
 Register Description: **Global Transceiver Clock Control Register**
 Register Address: **0F3h**

Bit #	7	6	5	4	3	2	1	0
Name	BPREFSEL3	BPREFSEL2	BPREFSEL1	BPREFSEL0	BFREQSEL	FREQSEL	MPS1	MPS0
Default	0	0	0	0	0	0	0	0

Bits 7 to 4: Backplane Clock Reference Selects (BPREFSEL[3:0]). These bits select which reference clock source will be used for BPCLK generation. The BPCLK can be generated from the LIU recovered clock, an external reference, or derivatives of MCLK input. This is shown in [Table 9-11](#). See [Figure 8-1](#) for additional information.

Bit 3: Backplane Frequency Select (BFREQSEL). In conjunction with BPRFSEL[3:0], this bit identifies the reference clock frequency used by the DS26524 backplane clock generation circuit. Note that the setting of this bit should match the T1E1 selection for the LIU whose recovered clock is being used to generate the backplane clock. See [Figure 8-1](#) for additional information.

- 0 = Backplane reference clock is 2.048MHz.
- 1 = Backplane reference clock is 1.544MHz.

Bit 2: Frequency Selection (FREQSEL). In conjunction with the MPS[1:0] bits, this bit selects the external MCLK frequency of the signal input at the MCLK pin of the DS26524.

- 0 = The external master clock is 2.048MHz or multiple thereof.
- 1 = The external master clock is 1.544MHz or multiple thereof.

Bits 1 and 0: Master Period Select 1 and 0 (MPS[1:0]). In conjunction with the FREQSEL bit, these bits select the external MCLK frequency of the signal input at the MCLK pin of the DS26524. This is shown in [Table 9-12](#).

Table 9-11. Backplane Reference Clock Select

BPREFSEL3	BPREFSEL2	BPREFSEL1	BPREFSEL0	BFREQSEL	REFERENCE CLOCK SOURCE
0	0	0	0	0	2.048MHz RCLK1
0	0	0	0	1	1.544MHz RCLK1
0	0	0	1	0	2.048MHz RCLK2
0	0	0	1	1	1.544MHz RCLK2
0	0	1	0	0	2.048MHz RCLK3
0	0	1	0	1	1.544MHz RCLK3
0	0	1	1	0	2.048MHz RCLK4
0	0	1	1	1	1.544MHz RCLK4
1	0	0	0	1	1.544MHz derived from MCLK. (REFCLKIO is an output.)
1	0	0	1	0	2.048MHz derived from MCLK. (REFCLKIO is an output.)
1	0	1	0	0	2.048MHz external clock input at REFCLKIO. (REFCLKIO is an input.)
1	0	1	0	1	1.544MHz external clock input at REFCLKIO. (REFCLKIO is an input.)

Table 9-12. Master Clock Input Selection

FREQSEL	MPS1	MPS0	MCLK (MHz \pm 50ppm)
0	0	0	2.048
0	0	1	4.096
0	1	0	8.192
0	1	1	16.384
1	0	0	1.544
1	0	1	3.088
1	1	0	6.176
1	1	1	12.352

Register Name: **GLSRR**
 Register Description: **Global LIU Software Reset Register**
 Register Address: **0F5h**

Bit #	7	6	5	4	3	2	1	0
Name	—	—	—	—	LSRST4	LSRST3	LSRST2	LSRST1
Default	0	0	0	0	0	0	0	0

Bit 3: Channel 4 LIU Software Reset (LSRST4). LIU logic and registers are reset with a 0-to-1 transition in this bit. The reset is released when a zero is written to this bit.

0 = Normal operation
 1 = Reset LIU

Bit 2: Channel 3 LIU Software Reset (LSRST3). LIU logic and registers are reset with a 0-to-1 transition in this bit. The reset is released when a zero is written to this bit.

0 = Normal operation
 1 = Reset LIU

Bit 1: Channel 2 LIU Software Reset (LSRST2). LIU logic and registers are reset with a 0-to-1 transition in this bit. The reset is released when a zero is written to this bit.

0 = Normal operation
 1 = Reset LIU

Bit 0: Channel 1 LIU Software Reset (LSRST1). LIU logic and registers are reset with a 0-to-1 transition in this bit. The reset is released when a zero is written to this bit.

0 = Normal operation
 1 = Reset LIU

Register Name: **GFSRR**
 Register Description: **Global Framer and BERT Software Reset Register**
 Register Address: **0F6h**

Bit #	7	6	5	4	3	2	1	0
Name	—	—	—	—	FSRST4	FSRST3	FSRST2	FSRST1
Default	0	0	0	0	0	0	0	0

Bit 3: Channel 4 Framer and BERT Software Reset (FSRST4). Framer logic and registers are reset with a 0-to-1 transition in this bit. The reset is released when a zero is written to this bit.

0 = Normal operation

1 = Reset framer and BERT

Bit 2: Channel 3 Framer and BERT Software Reset (FSRST3). Framer logic and registers are reset with a 0-to-1 transition in this bit. The reset is released when a zero is written to this bit.

0 = Normal operation

1 = Reset framer and BERT

Bit 1: Channel 2 Framer and BERT Software Reset (FSRST2). Framer logic and registers are reset with a 0-to-1 transition in this bit. The reset is released when a zero is written to this bit.

0 = Normal operation

1 = Reset framer and BERT

Bit 0: Channel 1 Framer and BERT Software Reset (FSRST1). Framer logic and registers are reset with a 0-to-1 transition in this bit. The reset is released when a zero is written to this bit.

0 = Normal operation

1 = Reset framer and BERT

Register Name: **IDR**
 Register Description: **Device Identification Register**
 Register Address: **0F8h**

Bit #	7	6	5	4	3	2	1	0
Name	ID7	ID6	ID5	ID4	ID3	ID2	ID1	ID0
Default	0	1	1	0	0	0	0	1

Bits 7 to 3: Device ID (ID[7:3]). The upper five bits of the IDR are used to display the DS26524 ID.

Table 9-13. Device ID Codes in this Product Family

DEVICE	ID7	ID6	ID5	ID4	ID3
DS26528	0	1	0	1	1
DS26524	0	1	1	0	0
DS26522	0	1	1	0	1
DS26521	0	1	1	1	0

Bits 2 to 0: Silicon Revision Bits (ID[2:0]). The lower three bits of the IDR are used to display a sequential number denoting the die revision of the chip. The initial silicon revision = "000," and is incremented with each silicon revision. This value is not the same as the two-character device revision on the top brand of the device. This is due to the fact that portions of the device assembly other than the silicon may change, causing the device revision increment on the brand without having a revision of the silicon. ID0 is the LSB of a decimal code that represents the chip revision.

Register Name: **GFISR**
 Register Description: **Global Framer Interrupt Status Register**
 Register Address: **0F9h**

Bit #	7	6	5	4	3	2	1	0
Name	—	—	—	—	FIS4	FIS3	FIS2	FIS1
Default	0	0	0	0	0	0	0	0

The GFISR register reports the framer interrupt status for each of the four T1/E1 framers. A logic one in the associated bit location indicates a framer has set its interrupt signal.

Bit 3: Framer Interrupt Status 4 (FIS4).

0 = Framer 4 has not issued an interrupt.

1 = Framer 4 has issued an interrupt.

Bit 0: Framer Interrupt Status 3 (FIS3).

0 = Framer 3 has not issued an interrupt.

1 = Framer 3 has issued an interrupt.

Bit 0: Framer Interrupt Status 2 (FIS2).

0 = Framer 2 has not issued an interrupt.

1 = Framer 2 has issued an interrupt.

Bit 0: Framer Interrupt Status 1 (FIS1).

0 = Framer 1 has not issued an interrupt.

1 = Framer 1 has issued an interrupt.

Register Name: **GBISR**
 Register Description: **Global BERT Interrupt Status Register**
 Register Address: **0FAh**

Bit #	7	6	5	4	3	2	1	0
Name	—	—	—	—	BIS4	BIS3	BIS2	BIS1
Default	0	0	0	0	0	0	0	0

The GBISR register reports the interrupt status for each of the four T1/E1 bit error-rate testers (BERTs). A logic one in the associated bit location indicates a BERT has set its interrupt signal.

Bit 3: BERT Interrupt Status 4 (BIS4).

0 = BERT 4 has not issued an interrupt.

1 = BERT 4 has issued an interrupt.

Bit 2: BERT Interrupt Status 3 (BIS3).

0 = BERT 3 has not issued an interrupt.

1 = BERT 3 has issued an interrupt.

Bit 1: BERT Interrupt Status 2 (BIS2).

0 = BERT 2 has not issued an interrupt.

1 = BERT 2 has issued an interrupt.

Bit 0: BERT Interrupt Status 1 (BIS1).

0 = BERT 1 has not issued an interrupt.

1 = BERT 1 has issued an interrupt.

Register Name: **GLISR**
 Register Description: **Global LIU Interrupt Status Register**
 Register Address: **0FBh**

Bit #	7	6	5	4	3	2	1	0
Name	—	—	—	—	LIS4	LIS3	LIS2	LIS1
Default	0	0	0	0	0	0	0	0

The GLISR register reports the LIU interrupt status for each of the four T1/E1 LIUs. A logic one in the associated bit location indicates a LIU has set its interrupt signal.

Bit 3: LIU Interrupt Status 4 (LIS4).

0 = LIU 4 has not issued an interrupt.

1 = LIU 4 has issued an interrupt.

Bit 2: LIU Interrupt Status 3 (LIS3).

0 = LIU 3 has not issued an interrupt.

1 = LIU 3 has issued an interrupt.

Bit 1: LIU Interrupt Status 2 (LIS2).

0 = LIU 2 has not issued an interrupt.

1 = LIU 2 has issued an interrupt.

Bit 0: LIU Interrupt Status 1 (LIS1).

0 = LIU 1 has not issued an interrupt.

1 = LIU 1 has issued an interrupt.

Register Name: **GFIMR**
 Register Description: **Global Framer Interrupt Mask Register**
 Register Address: **0FCh**

Bit #	7	6	5	4	3	2	1	0
Name	—	—	—	—	FIM4	FIM3	FIM2	FIM1
Default	0	0	0	0	0	0	0	0

Bit 3: Framer 4 Interrupt Mask (FIM4).

0 = Interrupt masked.
 1 = Interrupt enabled.

Bit 2: Framer 3 Interrupt Mask (FIM3).

0 = Interrupt masked.
 1 = Interrupt enabled.

Bit 1: Framer 2 Interrupt Mask (FIM2).

0 = Interrupt masked.
 1 = Interrupt enabled.

Bit 0: Framer 1 Interrupt Mask (FIM1).

0 = Interrupt masked.
 1 = Interrupt enabled.

Register Name: **GBIMR**
 Register Description: **Global BERT Interrupt Mask Register**
 Register Address: **0FDh**

Bit #	7	6	5	4	3	2	1	0
Name	—	—	—	—	BIM4	BIM3	BIM2	BIM1
Default	0	0	0	0	0	0	0	0

Bit 3: BERT Interrupt Mask 4 (BIM4).

0 = Interrupt masked.
 1 = Interrupt enabled.

Bit 2: BERT Interrupt Mask 3 (BIM3).

0 = Interrupt masked.
 1 = Interrupt enabled.

Bit 1: BERT Interrupt Mask 2 (BIM2).

0 = Interrupt masked.
 1 = Interrupt enabled.

Bit 0: BERT Interrupt Mask 1 (BIM1).

0 = Interrupt masked.
 1 = Interrupt enabled.

Register Name: **GLIMR**
 Register Description: **Global LIU Interrupt Mask Register**
 Register Address: **0FEh**

Bit #	7	6	5	4	3	2	1	0
Name	—	—	—	—	LIM4	LIM3	LIM2	LIM1
Default	0	0	0	0	0	0	0	0

Bit 3: LIU Interrupt Mask 4 (LIM4).

0 = Interrupt masked.
 1 = Interrupt enabled.

Bit 2: LIU Interrupt Mask 3 (LIM3).

0 = Interrupt masked.
 1 = Interrupt enabled.

Bit 1: LIU Interrupt Mask 2 (LIM2).

0 = Interrupt masked.
 1 = Interrupt enabled.

Bit 0: LIU Interrupt Mask 1 (LIM1).

0 = Interrupt masked.
 1 = Interrupt enabled.

9.4 Framer Register Definitions

See [Table 9-3](#) for the complete framer register list.

9.4.1 Receive Register Definitions

Register Name: **RHC**
 Register Description: **Receive HDLC Control Register**
 Register Address: **010h + (200h x n): where n = 0 to 3, for Ports 1 to 4**

Bit #	7	6	5	4	3	2	1	0
Name	RCRCD	RHR	RHMS	RHCS4	RHCS3	RHCS2	RHCS1	RHCS0
Default	0	0	0	0	0	0	0	0

Bit 7: Receive CRC-16 Display (RCRCD).

- 0 = Do not write received CRC-16 code to FIFO (default)
- 1 = Write received CRC-16 code to FIFO after last octet of packet

Bit 6: Receive HDLC Reset (RHR). Will reset the receive HDLC controller and flush the receive FIFO. Note that this bit is a acknowledged reset. The host should set this bit and the DS26524 will clear it once the reset operation is complete. The DS26524 will complete the HDLC reset within two frames.

- 0 = Normal operation
- 1 = Reset receive HDLC controller and flush the receive FIFO

Bit 5: Receive HDLC Mapping Select (RHMS).

- 0 = Receive HDLC assigned to channels
- 1 = Receive HDLC assigned to FDL (T1 mode), Sa bits (E1 mode)

Bit 4 to 0: Receive HDLC Channel Select 4 to 0 (RHCS[4:0]). These bits determine which DS0 is mapped to the HDLC controller when enabled with RHMS = 0. RHCS[4:0] = all 0s selects channel 1, RHCS[4:0] = all 1s selects channel 32 (E1). A change to the receive HDLC channel select is acknowledged only after a receive HDLC reset (RHR).

Register Name: **RHBSE**
 Register Description: **Receive HDLC Bit Suppress Register**
 Register Address: **011h + (200h x n): where n = 0 to 3, for Ports 1 to 4**

Bit #	7	6	5	4	3	2	1	0
Name	BSE8	BSE7	BSE6	BSE5	BSE4	BSE3	BSE2	BSE1
Default	0	0	0	0	0	0	0	0

Bit 7: Receive Channel Bit 8 Suppress (BSE8). MSB of the channel. Set to one to stop this bit from being used.

Bit 6: Receive Channel Bit 7 Suppress (BSE7). Set to one to stop this bit from being used.

Bit 5: Receive Channel Bit 6 Suppress (BSE6). Set to one to stop this bit from being used.

Bit 4: Receive Channel Bit 5 Suppress (BSE5). Set to one to stop this bit from being used.

Bit 3: Receive Channel Bit 4 Suppress (BSE4). Set to one to stop this bit from being used.

Bit 2: Receive Channel Bit 3 Suppress (BSE3). Set to one to stop this bit from being used.

Bit 1: Receive Channel Bit 2 Suppress (BSE2). Set to one to stop this bit from being used.

Bit 0: Receive Channel Bit 1 Suppress (BSE1). LSB of the channel. Set to one to stop this bit from being used.

Register Name: **RDS0SEL**
 Register Description: **Receive Channel Monitor Select Register**
 Register Address: **012h + (200h x n): where n = 0 to 3, for Ports 1 to 4**

Bit #	7	6	5	4	3	2	1	0
Name	—	—	—	RCM4	RCM3	RCM2	RCM1	RCM0
Default	0	0	0	0	0	0	0	0

Bits 4 to 0: Receive Channel Monitor Bits (RCM[4:0]). RCM0 is the LSB of a 5-bit channel select that determines which receive DS0 channel data will appear in the RDS0M register.

Register Name: **RSIGC**
 Register Description: **Receive-Signaling Control Register**
 Register Address: **013h + (200h x n): where n = 0 to 3, for Ports 1 to 4**

Bit #	7	6	5	4	3	2	1	0
Name	—	—	—	RFSA1	—	RSFF	RSFE	RSIE
	—	—	—	CASMS	—	RSFF	RSFE	RSIE
Default	0	0	0	0	0	0	0	0

Bit 4 (T1 Mode): Receive Force Signaling All Ones (RFSA1).

0 = do not force robbed bit signaling to all ones

1 = force signaling bits to all ones on a per-channel basis according to the [T1RSAOI1:T1RSAOI3](#) registers.

Bit 4 (E1 Mode): CAS Mode Select (CASMS).

0 = The DS26524 will initiate a resync when two consecutive multiframe alignment signals have been received with an error.

1 = The DS26524 will initiate a resync when two consecutive multiframe alignment signals have been received with an error, or 1 multiframe has been received with all the bits in time slot 16 in state 0.

Alignment criteria is met when at least one bit in state 1 is present in the time slot 16 preceding the multiframe alignment signal first detected (G.732 alternate criteria).

Bit 2: Receive-Signaling Force Freeze (RSFF). Freezes receive-side signaling at RSIG (and RSER if receive-signaling reinsertion is enabled); will override receive freeze enable (RFE).

0 = do not force a freeze event

1 = force a freeze event

Bit 1: Receive-Signaling Freeze Enable (RSFE).

0 = no freezing of receive-signaling data will occur

1 = allow freezing of receive-signaling data at RSIG (and RSER if receive-signaling reinsertion is enabled)

Bit 0: Receive-Signaling Integration Enable (RSIE).

0 = signaling changes of state reported on any change in selected channels

1 = signaling must be stable for three multiframes in order for a change of state to be reported

Register Name: **T1RCR2 (T1 Mode)**
 Register Description: **Receive Control Register 2**
 Register Address: **014h + (200h x n): where n = 0 to 3, for Ports 1 to 4**

Bit #	7	6	5	4	3	2	1	0
Name	—	—	—	RSLC96	OOF2	OOF1	RAIIE	RD4RM
Default	0	0	0	0	0	0	0	0

Bit 4: Receive SLC-96 Synchronizer Enable (RSLC96). See Section [8.9.4.5](#) for SLC-96 details.

0 = SLC-96 synchronizer is disabled

1 = SLC-96 synchronizer is enabled

Bits 3 and 2: Out of Frame Select Bits (OOF[2:1]).

OOF2	OOF1	OUT OF FRAME CRITERIA
0	0	2/4 frame bits in error
0	1	2/5 frame bits in error
1	0	2/6 frame bits in error
1	1	2/6 frame bits in error

Bit 1: Receive RAI Integration Enable (RAIIE). The ESF RAI indication can be interrupted for a period not to exceed 100ms per interruption (T1.403). In ESF mode, setting RAIIE will cause the RAI status from the DS26524 to be integrated for 200ms.

0 = RAI detects when 16 consecutive patterns of 00FF appear in the FDL.

RAI clears when 14 or fewer patterns of 00FF hex out of 16 possible appear in the FDL.

1 = RAI detects when the condition has been present for greater than 200ms.

RAI clears when the condition has been absent for greater than 200ms.

Bit 0: Receive-Side D4 Remote Alarm Select (RD4RM).

0 = zeros in bit 2 of all channels

1 = a one in the S-bit position of frame 12 (J1 Yellow Alarm Mode)

Register Name: **E1RSAIMR (E1 Mode Only)**
 Register Description: **Receive Sa-Bit Interrupt Mask Register**
 Register Address: **014h + (200h x n): where n = 0 to 3, for Ports 1 to 4**

Bit #	7	6	5	4	3	2	1	0
Name	—	—	—	RSa4IM	RSa5IM	RSa6IM	RSa7IM	RSa8IM
Default	0	0	0	0	0	0	0	0

Bit 4: Sa4 Change Detect Interrupt Mask (RSa4IM). This bit will enable the change detect interrupt for the Sa4 bits. Any change of state of the Sa4 bit will then generate an interrupt in [RLS7.0](#) to indicate the change of state.

0 = interrupt masked
 1 = interrupt enabled

Bit 3: Sa5 Change Detect Interrupt Mask (RSa5IM). This bit will enable the change detect interrupt for the Sa5 bits. Any change of state of the Sa5 bit will then generate an interrupt in [RLS7.0](#) to indicate the change of state.

0 = interrupt masked
 1 = interrupt enabled

Bit 2: Sa6 Change Detect Interrupt Mask (RSa6IM). This bit will enable the change detect interrupt for the Sa6 bits. Any change of state of the Sa6 bit will then generate an interrupt in [RLS7.0](#) to indicate the change of state.

0 = interrupt masked
 1 = interrupt enabled

Bit 1: Sa7 Change Detect Interrupt Mask (RSa7IM). This bit will enable the change detect interrupt for the Sa7 bits. Any change of state of the Sa7 bit will then generate an interrupt in [RLS7.0](#) to indicate the change of state.

0 = interrupt masked
 1 = interrupt enabled

Bit 0: Sa8 Change Detect Interrupt Mask (RSa8IM). This bit will enable the change detect interrupt for the Sa8 bits. Any change of state of the Sa8 bit will then generate an interrupt in [RLS7.0](#) to indicate the change of state.

0 = interrupt masked
 1 = interrupt enabled

Register Name: **T1RBOCC (T1 Mode Only)**
 Register Description: **Receive BOC Control Register**
 Register Address: **015h + (200h x n): where n = 0 to 3, for Ports 1 to 4**

Bit #	7	6	5	4	3	2	1	0
Name	RBR	—	RBD1	RBD0	—	RBF1	RBF0	—
Default	0	0	0	0	0	0	0	0

Bit 7: Receive BOC Reset (RBR). The host should set this bit to force a reset of the BOC circuitry. Note that this is an acknowledged reset, that is, the host need only set the bit and the DS26524 will clear it once the reset operation is complete (less than 250µs). Modifications to the RBF[1:0] and RBD[1:0] bits will not be applied to the BOC controller until a BOC reset has been completed.

Bits 5 and 4: Receive BOC Disintegration Bits (RBD[1:0]). The BOC disintegration filter sets the number of message bits that must be received without a valid BOC to set the BC bit indicating that a valid BOC is no longer being received.

RBD1	RBD0	CONSECUTIVE MESSAGE BITS FOR BOC CLEAR IDENTIFICATION
0	0	16
0	1	32
1	0	48
1	1	64 (See Note 1)

Bits 2 and 1: Receive BOC Filter Bits (RBF[1:0]). The BOC filter sets the number of consecutive patterns that must be received without error prior to an indication of a valid message.

RBF1	RBF0	CONSECUTIVE BOC CODES FOR VALID SEQUENCE IDENTIFICATION
0	0	None
0	1	3
1	0	5
1	1	7 (See Note 1)

Note 1: The DS26524's BOC controller does not integrate and disintegrate concurrently. Therefore, if the maximum integration time and the maximum disintegration time are used together, BOC messages that repeat fewer than 11 times may not be detected.

Register Name: **RIDR1 to RIDR32**
 Register Description: **Receive Idle Code Definition Registers 1 to 32**
 Register Address: **020h to 03Fh + (200h x n): where n = 0 to 3, for Ports 1 to 4**

Bit #	7	6	5	4	3	2	1	0
Name	C7	C6	C5	C4	C3	C2	C1	C0
Default	0	0	0	0	0	0	0	0

Bits 7 to 0: Per-Channel Idle Code Bits (C[7:0]). C0 is the LSB of the code (this bit is transmitted last). Address 020h is for channel 1. Address 037h is for channel 24. Address 03Fh is for channel 32. RIDR1:RIDR24 are T1 mode only. RIDR25:RIDR32 are E1 mode only.

Register Name: **T1RSAOI1, T1RSAOI2, T1RSAOI3 (T1 Mode Only)**
 Register Description: **Receive-Signaling All-Ones Insertion Registers 1 to 3**
 Register Address: **038h, 039h, 03Ah + (200h x n): where n = 0 to 3, for Ports 1 to 4**

Bit #	(MSB) 7	6	5	4	3	2	1	0 (LSB)	
Name	CH8	CH7	CH6	CH5	CH4	CH3	CH2	CH1	T1RSAOI1
	CH16	CH15	CH14	CH13	CH12	CH11	CH10	CH9	T1RSAOI2
	CH24	CH23	CH22	CH21	CH20	CH19	CH18	CH17	T1RSAOI3
Default	0	0	0	0	0	0	0	0	

Setting any of the CH[1:24] bits in the T1RSAOI1:T1RSAOI3 registers will cause signaling data to be replaced with logic ones as reported on RSER. The RSIG signal will continue to report received signaling data. Note that this feature must be enabled with control bit [RSIGC.4](#).

Register Name: **T1RDMWE1, T1RDMWE2, T1RDMWE3 (T1 Mode Only)**
 Register Description: **T1 Receive Digital Milliwatt Enable Registers 1 to 3**
 Register Address: **03Ch, 03Dh, 03Eh + (200h x n): where n = 0 to 3, for Ports 1 to 4**

Bit #	(MSB) 7	6	5	4	3	2	1	0 (LSB)	
Name	CH8	CH7	CH6	CH5	CH4	CH3	CH2	CH1	T1RDMWE1
	CH16	CH15	CH14	CH13	CH12	CH11	CH10	CH9	T1RDMWE2
	CH24	CH23	CH22	CH21	CH20	CH19	CH18	CH17	T1RDMWE3
Default	0	0	0	0	0	0	0	0	

Bits 7 to 0: Receive Digital Milliwatt Enable for Channels 1 to 24 (CH[1:24]).

0 =do not affect the receive data associated with this channel

1 = replace the receive data associated with this channel with digital milliwatt code

Register Name: **RS1 to RS16**
 Register Description: **Receive-Signaling Registers 1 to 16**
 Register Address: **040h to 04Fh + (200h x n): where n = 0 to 3, for Ports 1 to 4**

T1 Mode:
(MSB)

				(LSB)				
CH1-A	CH1-B	CH1-C	CH1-D	CH13-A	CH13-B	CH13-C	CH13-D	RS1
CH2-A	CH2-B	CH2-C	CH2-D	CH14-A	CH14-B	CH14-C	CH14-D	RS2
CH3-A	CH3-B	CH3-C	CH3-D	CH15-A	CH15-B	CH15-C	CH15-D	RS3
CH4-A	CH4-B	CH4-C	CH4-D	CH16-A	CH16-B	CH16-C	CH16-D	RS4
CH5-A	CH5-B	CH5-C	CH5-D	CH17-A	CH17-B	CH17-C	CH17-D	RS5
CH6-A	CH6-B	CH6-C	CH6-D	CH18-A	CH18-B	CH18-C	CH18-D	RS6
CH7-A	CH7-B	CH7-C	CH7-D	CH19-A	CH19-B	CH19-C	CH19-D	RS7
CH8-A	CH8-B	CH8-C	CH8-D	CH20-A	CH20-B	CH20-C	CH20-D	RS8
CH9-A	CH9-B	CH9-C	CH9-D	CH21-A	CH21-B	CH21-C	CH21-D	RS9
CH10-A	CH10-B	CH10-C	CH10-D	CH22-A	CH22-B	CH22-C	CH22-D	RS10
CH11-A	CH11-B	CH11-C	CH11-D	CH23-A	CH23-B	CH23-C	CH23-D	RS11
CH12-A	CH12-B	CH12-C	CH12-D	CH24-A	CH24-B	CH24-C	CH24-D	RS12

E1 Mode:
(MSB)

				(LSB)				
0	0	0	0	X	Y	X	X	RS1
CH1-A	CH1-B	CH1-C	CH1-D	CH16-A	CH16-B	CH16-C	CH16-D	RS2
CH2-A	CH2-B	CH2-C	CH2-D	CH17-A	CH17-B	CH17-C	CH17-D	RS3
CH3-A	CH3-B	CH3-C	CH3-D	CH18-A	CH18-B	CH18-C	CH18-D	RS4
CH4-A	CH4-B	CH4-C	CH4-D	CH19-A	CH19-B	CH19-C	CH19-D	RS5
CH5-A	CH5-B	CH5-C	CH5-D	CH20-A	CH20-B	CH20-C	CH20-D	RS6
CH6-A	CH6-B	CH6-C	CH6-D	CH21-A	CH21-B	CH21-C	CH21-D	RS7
CH7-A	CH7-B	CH7-C	CH7-D	CH22-A	CH22-B	CH22-C	CH22-D	RS8
CH8-A	CH8-B	CH8-C	CH8-D	CH23-A	CH23-B	CH23-C	CH23-D	RS9
CH9-A	CH9-B	CH9-C	CH9-D	CH24-A	CH24-B	CH24-C	CH24-D	RS10
CH10-A	CH10-B	CH10-C	CH10-D	CH25-A	CH25-B	CH25-C	CH25-D	RS11
CH11-A	CH11-B	CH11-C	CH11-D	CH26-A	CH26-B	CH26-C	CH26-D	RS12
CH12-A	CH12-B	CH12-C	CH12-D	CH27-A	CH27-B	CH27-C	CH27-D	RS13
CH13-A	CH13-B	CH13-C	CH13-D	CH28-A	CH28-B	CH28-C	CH28-D	RS14
CH14-A	CH14-B	CH14-C	CH14-D	CH29-A	CH29-B	CH29-C	CH29-D	RS15
CH15-A	CH15-B	CH15-C	CH15-D	CH30-A	CH30-B	CH30-C	CH30-D	RS16

In the ESF framing mode, there can be up to four signaling bits per channel (A, B, C, and D). In the D4 framing mode, there are only two signaling bits per channel (A and B). In the D4 framing mode, the framer will repeat the A and B signaling data in the C and D bit locations. Therefore, when the framer is operated in D4 framing mode, the user will need to retrieve the signaling bits every 1.5ms as opposed to 3ms for ESF mode. The receive-signaling registers are frozen and not updated during a loss of sync condition. They will contain the most recent signaling information before the "OOF" occurred.

Register Name: **LCVCR1**
 Register Description: **Line Code Violation Count Register 1**
 Register Address: **050h + (200h x n): where n = 0 to 3, for Ports 1 to 4**

Bit #	7	6	5	4	3	2	1	0
Name	LCVC15	LCVC14	LCVC13	LCVC12	LCVC11	LCVC10	LCVC9	LCVC8
Default	0	0	0	0	0	0	0	0

Bits 7 to 0: Line Code Violation Counter Bits 15 to 8 (LCVC[15:8]). LCVC15 is the MSB of the 16-bit code violation count.

Register Name: **LCVCR2**
 Register Description: **Line Code Violation Count Register 2**
 Register Address: **051h + (200h x n): where n = 0 to 3, for Ports 1 to 4**

Bit #	7	6	5	4	3	2	1	0
Name	LCVC7	LCVC6	LCVC5	LCVC4	LCVC3	LCVC2	LCVC1	LCVC0
Default	0	0	0	0	0	0	0	0

Bits 7 to 0: Line Code Violation Counter Bits 7 to 0 (LCVC[7:0]). LCVC0 is the LSB of the 16-bit code violation count.

Register Name: **PCVCR1**
 Register Description: **Path Code Violation Count Register 1**
 Register Address: **052h + (200h x n): where n = 0 to 3, for Ports 1 to 4**

Bit #	7	6	5	4	3	2	1	0
Name	PCVC15	PCVC14	PCVC13	PCVC12	PCVC11	PCVC10	PCVC9	PCVC8
Default	0	0	0	0	0	0	0	0

Bits 7 to 0: Path Code Violation Counter Bits 15 to 8 (PCVC[15:8]). PCVC15 is the MSB of the 16-bit path code violation count.

Register Name: **PCVCR2**
 Register Description: **Path Code Violation Count Register 2**
 Register Address: **053h + (200h x n): where n = 0 to 3, for Ports 1 to 4**

Bit #	7	6	5	4	3	2	1	0
Name	PCVC7	PCVC6	PCVC5	PCVC4	PCVC3	PCVC2	PCVC1	PCVC0
Default	0	0	0	0	0	0	0	0

Bits 7 to 0: Path Code Violation Counter Bits 0 to 7 (PCVC[7:0]). PCVC0 is the LSB of the 16-bit path code violation count.

Register Name: **FOSCR1**
 Register Description: **Frames Out of Sync Count Register 1**
 Register Address: **054h + (200h x n): where n = 0 to 3, for Ports 1 to 4**

Bit #	7	6	5	4	3	2	1	0
Name	FOS15	FOS14	FOS13	FOS12	FOS11	FOS10	FOS9	FOS8
Default	0	0	0	0	0	0	0	0

Bits 7 to 0: Frames Out of Sync Counter Bits 15 to 8 (FOS[15:8]). FOS15 is the MSB of the 16-bit frames out of sync count.

Register Name: **FOSCR2**
 Register Description: **Frames Out of Sync Count Register 2**
 Register Address: **055h + (200h x n): where n = 0 to 3, for Ports 1 to 4**

Bit #	7	6	5	4	3	2	1	0
Name	FOS7	FOS6	FOS5	FOS4	FOS3	FOS2	FOS1	FOS0
Default	0	0	0	0	0	0	0	0

Bits 7 to 0: Frames Out of Sync Counter Bits 7 to 0 (FOS[7:0]). FOS0 is the LSB of the 16-bit frames out of sync count.

Register Name: **E1EBCR1 (E1 Mode Only)**
 Register Description: **E-Bit Count Register 1**
 Register Address: **056h + (200h x n): where n = 0 to 3, for Ports 1 to 4**

Bit #	7	6	5	4	3	2	1	0
Name	EB15	EB14	EB13	EB12	EB11	EB10	EB9	EB8
Default	0	0	0	0	0	0	0	0

Bits 7 to 0: E-Bit Counter Bits 15 to 8 (EB[15:8]). EB15 is the MSB of the 16-bit E-bit count.

Register Name: **E1EBCR2 (E1 Mode Only)**
 Register Description: **E-Bit Count Register 2**
 Register Address: **057h + (200h x n): where n = 0 to 3, for Ports 1 to 4**

Bit #	7	6	5	4	3	2	1	0
Name	EB7	EB6	EB5	EB4	EB3	EB2	EB1	EB0
Default	0	0	0	0	0	0	0	0

Bits 7 to 0: E-Bit Counter Bits 7 to 0 (EB[7:0]). EB0 is the LSB of the 16-bit E-bit count.

Register Name: **RDS0M**
 Register Description: **Receive DS0 Monitor Register**
 Register Address: **060h + (200h x n): where n = 0 to 3, for Ports 1 to 4**

Bit #	7	6	5	4	3	2	1	0
Name	B1	B2	B3	B4	B5	B6	B7	B8
Default	0	0	0	0	0	0	0	0

Bits 7 to 0: Receive DS0 Channel Bits (B[1:8]). Receive channel data that has been selected by the Receive Channel Monitor Select register ([RDS0SEL](#)). B8 is the LSB of the DS0 channel (last bit to be received).

Register Name: **E1RFRID (E1 Mode Only)**
 Register Description: **Receive Firmware Revision ID Register**
 Register Address: **061h + (200h x n): where n = 0 to 3, for Ports 1 to 4**

Bit #	7	6	5	4	3	2	1	0
Name	FR7	FR6	FR5	FR4	FR3	FR2	FR1	FR0
Default	0	0	0	0	0	0	0	0

Bits 7 to 0: Firmware Revision (FR[7:0]). This read-only register reports the current revision of the receive firmware.

Register Name: **T1RFDL (T1 Mode)**
 Register Description: **Receive FDL Register**
 Register Address: **062h + (200h x n): where n = 0 to 3, for Ports 1 to 4**

Bit #	7	6	5	4	3	2	1	0
Name	RFDL7	RFDL6	RFDL5	RFDL4	RFDL3	RFDL2	RFDL1	RFDL0
Default	0	0	0	0	0	0	0	0

Note: This register has an alternate definition for E1 mode. See [E1RRTS7](#).

Bit 7: Receive FDL Bit 7 (RFDL7). MSB of the received FDL code.

Bit 6: Receive FDL Bit 6 (RFDL6).

Bit 5: Receive FDL Bit 5 (RFDL5).

Bit 4: Receive FDL Bit 4 (RFDL4).

Bit 3: Receive FDL Bit 3 (RFDL3).

Bit 2: Receive FDL Bit 2 (RFDL2).

Bit 1: Receive FDL Bit 1 (RFDL1).

Bit 0: Receive FDL Bit 0 (RFDL0). LSB of the received FDL code.

Register Name: **E1RRTS7 (E1 Mode)**
 Register Description: **Receive Real-Time Status Register 7**
 Register Address: **062h + (200h x n): where n = 0 to 3, for Ports 1 to 4**

Bit #	7	6	5	4	3	2	1	0
Name	CSC5	CSC4	CSC3	CSC2	CSC0	CRC4SA	CASSA	FASSA
Default	0	0	0	0	0	0	0	0

Note: This register has an alternate definition for T1 mode. See [T1RFDL](#). All bits in this register are real-time (not latched).

Bits 7 to 3: CRC-4 Sync Counter Bits (CSC[5:2] and CSC0). The CRC-4 sync counter increments each time the 8ms CRC-4 multiframe search times out. The counter is cleared when the framer has successfully obtained synchronization at the CRC-4 level. The counter can also be cleared by disabling the CRC-4 mode ([RCR1.3](#) = 0). This counter is useful for determining the amount of time the framer has been searching for synchronization at the CRC-4 level. ITU-T G.706 suggests that if synchronization at the CRC-4 level cannot be obtained within 400ms, then the search should be abandoned and proper action taken. The CRC-4 sync counter will saturate (not rollover). CSC0 is the LSB of the 6-bit counter. (CSC1 is omitted to allow resolution to > 400ms using 5 bits.)

Bit 2: CRC-4 MF Sync Active (CRC4SA). Set while the synchronizer is searching for the CRC-4 MF alignment word.

Bit 1: CAS MF Sync Active (CASSA). Set while the synchronizer is searching for the CAS MF alignment word.

Bit 0: FAS Sync Active (FASSA). Set while the synchronizer is searching for alignment at the FAS level.

Register Name: **T1RBOC (T1 Mode)**
 Register Description: **Receive BOC Register**
 Register Address: **063h + (200h x n): where n = 0 to 3, for Ports 1 to 4**

Bit #	7	6	5	4	3	2	1	0
Name	—	—	RBOC5	RBOC4	RBOC3	RBOC2	RBOC1	RBOC0
Default	0	0	0	0	0	0	0	0

Bit 5: BOC Bit 5 (RBOC5).

Bit 4: BOC Bit 4 (RBOC4).

Bit 3: BOC Bit 3 (RBOC3).

Bit 2: BOC Bit 2 (RBOC2).

Bit 1: BOC Bit 1 (RBOC1).

Bit 0: BOC Bit 0 (RBOC0).

The T1RBOC register always contains the last valid BOC received. The Receive FDL register ([T1RFDL](#)) reports the incoming Facility Data Link (FDL) or the incoming Fs bits. The LSB is received first. In D4 framing mode, RFDL updates on multiframe boundaries and reports the six Fs bits in RFDL[5:0].

Register Name: **T1RSLC1, T1RSLC2, T1RSLC3 (T1 Mode)**
 Register Description: **Receive SLC-96 Data Link Registers 1 to 3**
 Register Address: **064h, 065h, 066h + (200h x n): where n = 0 to 3, for Ports 1 to 4**

Bit #	(MSB) 7	6	5	4	3	2	1	0 (LSB)	
Name	C8	C7	C6	C5	C4	C3	C2	C1	T1RSLC1
	M2	M1	S=0	S=1	S=0	C11	C10	C9	T1RSLC2
	S=1	S4	S3	S2	S1	A2	A1	M3	T1RSLC3
Default	0	0	0	0	0	0	0	0	

Note: These registers have an alternate definition for E1 mode. See [E1RAF](#), [E1RNAF](#), and [E1RSIAF](#).

Register Name: **E1RAF (E1 Mode)**
 Register Description: **E1 Receive Align Frame Register**
 Register Address: **064h + (200h x n): where n = 0 to 3, for Ports 1 to 4**

Bit #	7	6	5	4	3	2	1	0
Name	Si	0	0	1	1	0	1	1
Default	0	0	0	0	0	0	0	0

Note: This register has an alternate definition for T1 mode. See [T1RSLC1](#).

Bit 7: International Bit (Si).

Bit 6: Frame Alignment Signal Bit (0).

Bit 5: Frame Alignment Signal Bit (0).

Bit 4: Frame Alignment Signal Bit (1).

Bit 3: Frame Alignment Signal Bit (1).

Bit 2: Frame Alignment Signal Bit (0).

Bit 1: Frame Alignment Signal Bit (1).

Bit 0: Frame Alignment Signal Bit (1).

Register Name: **E1RNAF (E1 Mode)**
 Register Description: **E1 Receive Non-Align Frame Register**
 Register Address: **065h + (200h x n): where n = 0 to 3, for Ports 1 to 4**

Bit #	7	6	5	4	3	2	1	0
Name	Si	1	A	Sa4	Sa5	Sa6	Sa7	Sa8
Default	0	0	0	0	0	0	0	0

Note: This register has an alternate definition for T1 mode. See [T1RSLC2](#).

Bit 7: International Bit (Si).

Bit 6: Frame Non-Alignment Signal Bit (1).

Bit 5: Remote Alarm (A).

Bit 4: Additional Bit 4 (Sa4).

Bit 3: Additional Bit 5 (Sa5).

Bit 2: Additional Bit 6 (Sa6).

Bit 1: Additional Bit 7 (Sa7).

Bit 0: Additional Bit 8 (Sa8).

Register Name: **E1RSiAF (E1 Mode)**
 Register Description: **E1 Received Si Bits of the Align Frame Register**
 Register Address: **066h + (200h x n): where n = 0 to 3, for Ports 1 to 4**

Bit #	7	6	5	4	3	2	1	0
Name	SiF14	SiF12	SiF10	SiF8	SiF6	SiF4	SiF2	SiF0
Default	0	0	0	0	0	0	0	0

Note: This register has an alternate definition for T1 mode. See [T1RSLC3](#).

Bit 7: Si Bit of Frame 14 (SiF14).

Bit 6: Si Bit of Frame 12 (SiF12).

Bit 5: Si Bit of Frame 10 (SiF10).

Bit 4: Si Bit of Frame 8 (SiF8).

Bit 3: Si Bit of Frame 6 (SiF6).

Bit 2: Si Bit of Frame 4 (SiF4).

Bit 1: Si Bit of Frame 2 (SiF2).

Bit 0: Si Bit of Frame 0 (SiF0).

Register Name: **E1RSiNAF (E1 Mode Only)**
 Register Description: **Receive Si Bits of the Non-Align Frame Register**
 Register Address: **067h + (200h x n): where n = 0 to 3, for Ports 1 to 4**

Bit #	7	6	5	4	3	2	1	0
Name	SiF15	SiF13	SiF11	SiF9	SiF7	SiF5	SiF3	SiF1
Default	0	0	0	0	0	0	0	0

Bit 7: Si Bit of Frame 15 (SiF15).

Bit 6: Si Bit of Frame 13 (SiF13).

Bit 5: Si Bit of Frame 11 (SiF11).

Bit 4: Si Bit of Frame 9 (SiF9).

Bit 3: Si Bit of Frame 7 (SiF7).

Bit 2: Si Bit of Frame 5 (SiF5).

Bit 1: Si Bit of Frame 3 (SiF3).

Bit 0: Si Bit of Frame 1 (SiF1).

Register Name: **E1RRA (E1 Mode Only)**
 Register Description: **Receive Remote Alarm Register**
 Register Address: **068h + (200h x n): where n = 0 to 3, for Ports 1 to 4**

Bit #	7	6	5	4	3	2	1	0
Name	RRAF15	RRAF13	RRAF11	RRAF9	RRAF7	RRAF5	RRAF3	RRAF1
Default	0	0	0	0	0	0	0	0

Bit 7: Remote Alarm Bit of Frame 15 (RRAF15).

Bit 6: Remote Alarm Bit of Frame 13 (RRAF13).

Bit 5: Remote Alarm Bit of Frame 11 (RRAF11).

Bit 4: Remote Alarm Bit of Frame 9 (RRAF9).

Bit 3: Remote Alarm Bit of Frame 7 (RRAF7).

Bit 2: Remote Alarm Bit of Frame 5 (RRAF5).

Bit 1: Remote Alarm Bit of Frame 3 (RRAF3).

Bit 0: Remote Alarm Bit of Frame 1 (RRAF1).

Register Name: **E1RSa4 (E1 Mode Only)**
 Register Description: **Receive Sa4 Bits Register**
 Register Address: **069h + (200h x n): where n = 0 to 3, for Ports 1 to 4**

Bit #	7	6	5	4	3	2	1	0
Name	RSa4F15	RSa4F13	RSa4F11	RSa4F9	RSa4F7	RSa4F5	RSa4F3	RSa4F1
Default	0	0	0	0	0	0	0	0

Bit 7: Sa4 Bit of Frame 15 (RSa4F15).

Bit 6: Sa4 Bit of Frame 13 (RSa4F13).

Bit 5: Sa4 Bit of Frame 11 (RSa4F11).

Bit 4: Sa4 Bit of Frame 9 (RSa4F9).

Bit 3: Sa4 Bit of Frame 7 (RSa4F7).

Bit 2: Sa4 Bit of Frame 5 (RSa4F5).

Bit 1: Sa4 Bit of Frame 3 (RSa4F3).

Bit 0: Sa4 Bit of Frame 1 (RSa4F1).

Register Name: **E1RSa5 (E1 Mode Only)**
 Register Description: **Receive Sa5 Bits Register**
 Register Address: **06Ah + (200h x n): where n = 0 to 3, for Ports 1 to 4**

Bit #	7	6	5	4	3	2	1	0
Name	RSa5F15	RSa5F13	RSa5F11	RSa5F9	RSa5F7	RSa5F5	RSa5F3	RSa5F1
Default	0	0	0	0	0	0	0	0

Bit 7: Sa5 Bit of Frame 15 (RSa5F15).

Bit 6: Sa5 Bit of Frame 13 (RSa5F13).

Bit 5: Sa5 Bit of Frame 11 (RSa5F11).

Bit 4: Sa5 Bit of Frame 9 (RSa5F9).

Bit 3: Sa5 Bit of Frame 7 (RSa5F7).

Bit 2: Sa5 Bit of Frame 5 (RSa5F5).

Bit 1: Sa5 Bit of Frame 3 (RSa5F3).

Bit 0: Sa5 Bit of Frame 1 (RSa5F1).

Register Name: **E1RSa6 (E1 Mode Only)**
 Register Description: **Receive Sa6 Bits Register**
 Register Address: **06Bh + (200h x n): where n = 0 to 3, for Ports 1 to 4**

Bit #	7	6	5	4	3	2	1	0
Name	RSa6F15	RSa6F13	RSa6F11	RSa6F9	RSa6F7	RSa6F5	RSa6F3	RSa6F1
Default	0	0	0	0	0	0	0	0

Bit 7: Sa6 Bit of Frame 15 (RSa6F15).

Bit 6: Sa6 Bit of Frame 13 (RSa6F13).

Bit 5: Sa6 Bit of Frame 11 (RSa6F11).

Bit 4: Sa6 Bit of Frame 9 (RSa6F9).

Bit 3: Sa6 Bit of Frame 7 (RSa6F7).

Bit 2: Sa6 Bit of Frame 5 (RSa6F5).

Bit 1: Sa6 Bit of Frame 3 (RSa6F3).

Bit 0: Sa6 Bit of Frame 1 (RSa6F1).

Register Name: **E1RSa7 (E1 Mode Only)**
 Register Description: **Receive Sa7 Bits Register**
 Register Address: **06Ch + (200h x n): where n = 0 to 3, for Ports 1 to 4**

Bit #	7	6	5	4	3	2	1	0
Name	RSa7F15	RSa7F13	RSa7F11	RSa7F9	RSa7F7	RSa7F5	RSa7F3	RSa7F1
Default	0	0	0	0	0	0	0	0

Bit 7: Sa7 Bit of Frame 15 (RSa7F15).

Bit 6: Sa7 Bit of Frame 13 (RSa7F13).

Bit 5: Sa7 Bit of Frame 11 (RSa7F11).

Bit 4: Sa7 Bit of Frame 9 (RSa7F9).

Bit 3: Sa7 Bit of Frame 7 (RSa7F7).

Bit 2: Sa7 Bit of Frame 5 (RSa7F5).

Bit 1: Sa7 Bit of Frame 3 (RSa7F3).

Bit 0: Sa7 Bit of Frame 1 (RSa7F1).

Register Name: **E1RSa8 (E1 Mode Only)**
 Register Description: **Receive Sa8 Bits Register**
 Register Address: **06Dh + (200h x n): where n = 0 to 3, for Ports 1 to 4**

Bit #	7	6	5	4	3	2	1	0
Name	RSa8F15	RSa8F13	RSa8F11	RSa8F9	RSa8F7	RSa8F5	RSa8F3	RSa8F1
Default	0	0	0	0	0	0	0	0

Bit 7: Sa8 Bit of Frame 15 (RSa8F15).

Bit 6: Sa8 Bit of Frame 13 (RSa8F13).

Bit 5: Sa8 Bit of Frame 11 (RSa8F11).

Bit 4: Sa8 Bit of Frame 9 (RSa8F9).

Bit 3: Sa8 Bit of Frame 7 (RSa8F7).

Bit 2: Sa8 Bit of Frame 5 (RSa8F5).

Bit 1: Sa8 Bit of Frame 3 (RSa8F3).

Bit 0: Sa8 Bit of Frame 1 (RSa8F1).

Register Name: **SaBITS**
 Register Description: **Receive SaX Bits Register**
 Register Address: **06Eh + (200h x n): where n = 0 to 3, for Ports 1 to 4**

Bit #	7	6	5	4	3	2	1	0
Name	—	—	—	Sa4	Sa5	Sa6	Sa7	Sa8
Default	0	0	0	0	0	0	0	0

This register indicates the last received SaX bit. This can be used in conjunction with the [RLS7](#) register to determine which SaX bits have changed. The user can program which Sa bit positions should be monitored via the [E1RSAIMR](#) register, and when a change is detected through an interrupt in [RLS7.0](#), the user can determine which bit has changed by reading this register and comparing it with previous known values.

Bit 4: Last Received Sa4 Bit (Sa4).

Bit 3: Last Received Sa5 Bit (Sa5).

Bit 2: Last Received Sa6 Bit (Sa6).

Bit 1: Last Received Sa7 Bit (Sa7).

Bit 0: Last Received Sa8 Bit (Sa8).

Register Name: **Sa6CODE**
 Register Description: **Received Sa6 Codeword Register**
 Register Address: **06Fh + (200h x n): where n = 0 to 3, for Ports 1 to 4**

Bit #	7	6	5	4	3	2	1	0
Name	—	—	—	—	Sa6n	Sa6n	Sa6n	Sa6n
Default	0	0	0	0	0	0	0	0

This register reports the received Sa6 codeword per ETS 300 233. The bits are monitored on a submultiframe asynchronous basis, so the pattern reported could be one of multiple patterns that would represent a valid codeword. The table below indicates which patterns reported in this register correspond to a given valid Sa6 codeword.

Bits 3 to 0: Sa6 Codeword Bit (Sa6n).

VALID Sa6 CODE	POSSIBLE REPORTED PATTERNS
Sa6_8	1000, 0100, 0010, 0001
Sa6_A	1010, 0101
Sa6_C	110, 0110, 0011, 1001
Sa6_E	1110, 0111, 1011, 1101
Sa6_F	1111

Register Name: **RMMR**
 Register Description: **Receive Master Mode Register**
 Register Address: **080h + (200h x n): where n = 0 to 3, for Ports 1 to 4**

Bit #	7	6	5	4	3	2	1	0
Name	FRM_EN	INIT_DONE	—	—	—	—	SFTRST	T1/E1
Default	0	0	0	0	0	0	0	0

Bit 7: Framer Enable (FRM_EN). This bit must be set to the desired state before writing INIT_DONE.
 0 = Framer disabled—held in low-power state
 1 = Framer enabled—all features active

Bit 6: Initialization Done (INIT_DONE). The user must set this bit once he has written the configuration registers. The host is required to write or clear all device registers prior to setting this bit. Once INIT_DONE is set, the DS26524 will check the FRM_EN bit and, if enabled, will begin operation based on the initial configuration.

Bit 1: Soft Reset (SFTRST). Level sensitive soft reset. Should be taken high then low to reset the receiver.
 0 = Normal operation
 1 = Reset the receiver

Bit 0: Receiver T1/E1 Mode Select (T1/E1). Sets operating mode for receiver only! This bit must be set to the desired state before writing INIT_DONE.
 0 = T1 operation
 1 = E1 operation

Register Name: **RCR1 (T1 Mode)**
 Register Description: **Receive Control Register 1**
 Register Address: **081h + (200h x n): where n = 0 to 3, for Ports 1 to 4**

Bit #	7	6	5	4	3	2	1	0
Name	SYNCT	RB8ZS	RFM	ARC	SYNCC	RJC	SYNCE	RESYNC
Default	0	0	0	0	0	0	0	0

Note: This register has an alternate definition for E1 mode. See [RCR1](#).

Bit 7: Sync Time (SYNCT).

- 0 = qualify 10 bits
- 1 = qualify 24 bits

Bit 6: Receive B8ZS Enable (RB8ZS).

- 0 = B8ZS disabled
- 1 = B8ZS enabled

Bit 5: Receive Frame Mode Select (RFM).

- 0 = ESF framing mode
- 1 = D4 framing mode

Bit 4: Auto Resync Criteria (ARC).

- 0 = resync on OOF or LOS event
- 1 = resync on OOF only

Bit 3: Sync Criteria (SYNCC).

In D4 Framing Mode:

- 0 = search for Ft pattern, then search for Fs pattern
- 1 = cross couple Ft and Fs pattern

In ESF Framing Mode:

- 0 = search for FPS pattern only
- 1 = search for FPS and verify with CRC-6

Bit 2: Receive Japanese CRC6 Enable (RJC).

- 0 = use ANSI:AT&T:ITU-T CRC-6 calculation (normal operation)
- 1 = use Japanese standard JT-G704 CRC-6 calculation

Bit 1: Sync Enable (SYNCE).

- 0 = auto resync enabled
- 1 = auto resync disabled

Bit 0: Resynchronize (RESYNC). When toggled from low to high, a resynchronization of the receive-side framer is initiated. Must be cleared and set again for a subsequent resync.

Register Name: **RCR1 (E1 Mode)**
 Register Description: **Receive Control Register 1**
 Register Address: **081h + (200h x n): where n = 0 to 3, for Ports 1 to 4**

Bit #	7	6	5	4	3	2	1	0
Name	—	RHDB3	RSIGM	RG802	RCRC4	FRC	SYNCE	RESYNC
Default	0	0	0	0	0	0	0	0

Note: This register has an alternate definition for T1 mode. See [RCR1](#).

Bit 6: Receive HDB3 Enable (RHDB3).

- 0 = HDB3 disabled
- 1 = HDB3 enabled (decoded per O.162)

Bit 5: Receive-Signaling Mode Select (RSIGM).

- 0 = CAS signaling mode
- 1 = CCS signaling mode

Bit 4: Receive G.802 Enable (RG802). See [Figure 10-23](#) for details.

- 0 = do not force RCHBLK high during bit 1 of time slot 26
- 1 = force RCHBLK high during bit 1 of time slot 26

Bit 3: Receive CRC-4 Enable (RCRC4).

- 0 = CRC-4 disabled
- 1 = CRC-4 enabled

Bit 2: Frame Resync Criteria (FRC).

- 0 = resync if FAS received in error three consecutive times
- 1 = resync if FAS or bit 2 of non-FAS is received in error three consecutive times

Bit 1: Sync Enable (SYNCE).

- 0 = auto resync enabled
- 1 = auto resync disabled

Bit 0: Resynchronize (RESYNC). When toggled from low to high, a resynchronization of the receive-side framer is initiated. Must be cleared and set again for a subsequent resync.

Register Name: **T1RIBCC (T1 Mode)**
 Register Description: **Receive In-Band Code Control Register**
 Register Address: **082h + (200h x n): where n = 0 to 3, for Ports 1 to 4**

Bit #	7	6	5	4	3	2	1	0
Name	—	—	RUP2	RUP1	RUP0	RDN2	RDN1	RDN0
Default	0	0	0	0	0	0	0	0

Note: This register has an alternate definition for E1 mode. See [E1RCR2](#).

Bits 5 to 3: Receive Up Code Length Definition Bits (RUP[2:0]).

RUP2	RUP1	RUP0	LENGTH SELECTED
0	0	0	1 bits
0	0	1	2 bits
0	1	0	3 bits
0	1	1	4 bits
1	0	0	5 bits
1	0	1	6 bits
1	1	0	7 bits
1	1	1	8 : 16 bits

Bits 2 to 0: Receive Down Code Length Definition Bits (RDN[2:0]).

RDN2	RDN1	RDN0	LENGTH SELECTED
0	0	0	1 bits
0	0	1	2 bits
0	1	0	3 bits
0	1	1	4 bits
1	0	0	5 bits
1	0	1	6 bits
1	1	0	7 bits
1	1	1	8 : 16 bits

Register Name: **E1RCR2 (E1 Mode)**
 Register Description: **Receive Control Register 2**
 Register Address: **082h + (200h x n): where n = 0 to 3, for Ports 1 to 4**

Bit #	7	6	5	4	3	2	1	0
Name	RSa8S	RSa7S	RSa6S	RSa5S	RSa4S	—	—	RLOSA
Default	0	0	0	0	0	0	0	0

Note: This register has an alternate definition for T1 mode. See [T1RIBCC](#).

Bit 7: Sa8 Bit Select (RSa8S). Set to one to have RLCLK pulse at the Sa8 bit position; set to zero to force RLCLK low during Sa8 bit position.

Bit 6: Sa7 Bit Select (RSa7S). Set to one to have RLCLK pulse at the Sa7 bit position; set to zero to force RLCLK low during Sa7 bit position.

Bit 5: Sa6 Bit Select (RSa6S). Set to one to have RLCLK pulse at the Sa6 bit position; set to zero to force RLCLK low during Sa6 bit position.

Bit 4: Sa5 Bit Select (RSa5S). Set to one to have RLCLK pulse at the Sa5 bit position; set to zero to force RLCLK low during Sa5 bit position.

Bit 3: Sa4 Bit Select (RSa4S). Set to one to have RLCLK pulse at the Sa4 bit position; set to zero to force RLCLK low during Sa4 bit position.

Bit 0: Receive Loss of Signal Alternate Criteria (RLOSA). Defines the criteria for a loss-of-signal condition.

0 = LOS declared upon 255 consecutive zeros (125µs)

1 = LOS declared upon 2048 consecutive zeros (1ms)

Register Name: **RCR3**
 Register Description: **Receive Control Register 3**
 Register Address: **083h + (200h x n): where n = 0 to 3, for Ports 1 to 4**

Bit #	7	6	5	4	3	2	1	0
Name	IDF	—	RSERC	—	—	—	PLB	FLB
Default	0	0	0	0	0	0	0	0

Bit 7: Input Data Format (IDF).

0 = bipolar data is expected at RTIP and RRING (either AMI or B8ZS)

1 = NRZ data is expected at RTIP. The BPV counter will be disabled and RRING will be ignored by the DS26524.

Bit 5: RSER Control (RSERC).

0 = allow RSER to output data as received under all conditions (normal operation)

1 = force RSER to one under loss of frame alignment conditions

Bit 1: Payload Loopback (PLB).

0 = loopback disabled

1 = loopback enabled

When PLB is enabled, the following will occur:

- 1) Data will be transmitted from the TTIP and TRING pins synchronous with RCLK instead of TCLK.
- 2) All the receive-side signals will continue to operate normally.
- 3) The TCHCLK and TCHBLK signals are forced low.
- 4) Data at the TSER, TDATA, and TSIG pins is ignored.
- 5) The TLCLK signal will become synchronous with RCLK instead of TCLK.

In a PLB situation, the DS26524 loops the 192 bits (248 for E1) of payload data (with BPVs corrected) from the receive section back to the transmit section. The transmitter follows the frame alignment provided by the receiver. The receive frame boundary is automatically fed into the transmit section, such that the transmit frame position is locked to the receiver (i.e., TSYNC is sourced from RSYNC). The FPS framing pattern, CRC-6 calculation, and the FDL bits (FAS word, Si, Sa, E-bits, and CRC-4 for E1) are not looped back. Rather, they are reinserted by the DS26524 (i.e., the transmit section will modify the payload as if it was input at TSER).

Bit 0: Framer Loopback (FLB).

0 = loopback disabled

1 = loopback enabled

This loopback is useful in testing and debugging applications. In FLB, the DS26524 loops data from the transmit side back to the receive side. When FLB is enabled, the following will occur:

- 1) (T1 mode) An unframed all-ones code will be transmitted at TTIP and TRING.
(E1 mode) Normal data will be transmitted at TTIP and TRING.
- 2) Data at RTIP and RRING will be ignored.
- 3) All receive-side signals will take on timing synchronous with TCLK instead of RCLK.
- 4) Note that it is not acceptable to have RCLK tied to TCLK during this loopback because this will cause an unstable condition.

Register Name: **RIOCR**
 Register Description: **Receive I/O Configuration Register**
 Register Address: **084h + (200h x n): where n = 0 to 3, for Ports 1 to 4**

Bit #	7	6	5	4	3	2	1	0
Name	RCLKINV	RSYNCINV	H100EN	RSCLKM	RSMS	RSIO	RSMS2	RSMS1
	<i>RCLKINV</i>	<i>RSYNCINV</i>	<i>H100EN</i>	<i>RSCLKM</i>	—	<i>RSIO</i>	<i>RSMS2</i>	<i>RSMS1</i>
Default	0	0	0	0	0	1	0	0

Bit 7: RCLK Invert (RCLKINV).

0 = no inversion
 1 = invert RCLK as input

Bit 6: RSYNC Invert (RSYNCINV).

0 = no inversion
 1 = invert RSYNC as either input or output

Bit 5: H.100 SYNC Mode (H100EN). See Section [8.8.3](#) for more information.

0 = normal operation
 1 = RSYNC and TSSYNCIO signals are shifted

Bit 4: RSYCLK Mode Select (RSCLKM).

0 = if RSYCLK is 1.544MHz
 1 = if RSYCLK is 2.048MHz or IBO enabled

Bit 3: RSYNC Multiframe Skip Control (RSMS) (T1 Mode Only). Useful in framing format conversions from D4 to ESF. This function is not available when the receive-side elastic store is enabled. RSYNC must be set to output multiframe pulses.

0 = RSYNC will output a pulse at every multiframe
 1 = RSYNC will output a pulse at every other multiframe

Bit 2: RSYNC I/O Select (RSIO). (Note: This bit must be set to zero when elastic store is disabled) The default value for this bit is a logic 1 so that the default state of RSYNC is as an input.

0 = RSYNC is an output
 1 = RSYNC is an input (only valid if elastic store enabled)

Bit 1: RSYNC Mode Select 2 (RSMS2).

T1 Mode: RSYNC pin must be programmed in the output frame mode.

0 = do not pulse double-wide in signaling frames
 1 = do pulse double-wide in signaling frames

E1 Mode: RSYNC pin must be programmed in the output multiframe mode.

0 = RSYNC outputs CAS multiframe boundaries
 1 = RSYNC outputs CRC-4 multiframe boundaries

In E1 mode, RSMS2 also selects which multiframe signal is available at the RMSYNC pin, regardless of the configuration for RSYNC. When RSMS2 = 0, RMSYNC outputs CAS multiframe boundaries; when RSMS2 = 1, RMSYNC outputs CRC-4 multiframe boundaries.

Bit 0: RSYNC Mode Select 1 (RSMS1). Selects frame or multiframe pulse when RSYNC pin is in output mode. In input mode (elastic store must be enabled) multiframe mode is only useful when receive-signaling reinsertion is enabled.

0 = frame mode
 1 = multiframe mode

Register Name: **RESCR**
 Register Description: **Receive Elastic Store Control Register**
 Register Address: **085h + (200h x n): where n = 0 to 3, for Ports 1 to 4**

Bit #	7	6	5	4	3	2	1	0
Name	RDATFMT	RGCLKEN	—	RSZS	RESALGN	RESR	RESMDM	RESE
Default	0	0	0	0	0	0	0	0

Bit 7: Receive Channel Data Format (RDATFMT).

- 0 = 64kbps (data contained in all 8 bits)
- 1 = 56kbps (data contained in 7 out of the 8 bits)

Bit 6: Receive Gapped Clock Enable (RGCLKEN).

- 0 = RCHCLK functions normally
- 1 = Enable gapped bit clock output on RCHCLK

Note: *RGPKEN and RDATFMT are not associated with the elastic store and are explained in the fractional support section.*

Bit 4: Receive Slip Zone Select (RSZS). This bit determines the minimum distance allowed between the elastic store read and write pointers before forcing a controlled slip. This bit only applies during T1-to-E1 or E1-to-T1 conversion applications.

- 0 = force a slip at 9 bytes or less of separation (used for clustered blank channels)
- 1 = force a slip at 2 bytes or less of separation (used for distributed blank channels and minimum delay mode)

Bit 3: Receive Elastic Store Align (RESALGN). Setting this bit from 0 to 1 forces the receive elastic store's write/read pointers to a minimum separation of half a frame. No action is taken if the pointer separation is already greater or equal to half a frame. If pointer separation is less than half a frame, the command is executed and the data is disrupted. Should be toggled after RSYCLK has been applied and is stable. Must be cleared and set again for a subsequent align.

Bit 2: Receive Elastic Store Reset (RESR). Setting this bit from 0 to 1 forces the read pointer into the same frame that the write pointer is exiting, minimizing the delay through the elastic store. If this command should place the pointers within the slip zone (see bit 4), then an immediate slip occurs and the pointers move back to opposite frames. Should be toggled after RSYCLK has been applied and is stable. Do not leave this bit set HIGH.

Bit 1: Receive Elastic Store Minimum Delay Mode (RESMDM).

- 0 = elastic stores operate at full two-frame depth
- 1 = elastic stores operate at 32-bit depth

Bit 0: Receive Elastic Store Enable (RESE).

- 0 = elastic store is bypassed
- 1 = elastic store is enabled

Register Name: **ERCNT**
 Register Description: **Error-Counter Configuration Register**
 Register Address: **086h + (200h x n): where n = 0 to 3, for Ports 1 to 4**

Bit #	7	6	5	4	3	2	1	0
Name	1SECS	MCUS	MECU	ECUS	EAMS	FSBE	MOSCRF	LCVCRF
	<i>1SECS</i>	<i>MCUS</i>	<i>MECU</i>	<i>ECUS</i>	<i>EAMS</i>	—	—	<i>LCVCRF</i>
Default	0	0	0	0	0	0	0	0

Bit 7: One-Second Select (1SECS). This bit allows for synchronization of the error counter updates between multiple ports. When ERCNT.3 = 0, setting this bit (on a specific framer) will update the framer's error counters on the transition of the one-second timer from framer 1. Note that this bit should always be clear for framer 1.

- 0 = use the one-second timer that is internal to the framer
- 1 = use the one-second timer from framer 1 to latch updates

Bit 6: Manual Counter Update Select (MCUS). When manual update mode is enabled with EAMS, this bit can be used to allow the incoming LATCH_CNT signal to latch all counters.

- 0 = MECU is used to manually latch counters
- 1 = counters are latched on the rising edge of the LATCH_CNT signal

Bit 5: Manual Error Counter Update (MECU). When enabled by ERCNT.3, the changing of this bit from 0 to 1 allows the next clock cycle to load the error counter registers with the latest counts and reset the counters. The user must wait a minimum of 250µs before reading the error count registers to allow for proper update.

Bit 4: Error Counter Update Select (ECUS).

T1 Mode:

- 0 = update error counters once a second
- 1 = update error counters every 42ms (333 frames)

E1 Mode:

- 0 = update error counters once a second
- 1 = update error counters every 62.5ms (500 frames)

Bit 3: Error Accumulation Mode Select (EAMS).

- 0 = automatic updating of error counters enabled. The state of ERCNT.4 determines accumulation time (timed update)
- 1 = user toggling of ERCNT.5 determines accumulation time (manual update)

Bit 2: PCVCR Fs-Bit Error Report Enable (FSBE) (T1 Mode Only).

- 0 = do not report bit errors in Fs-bit position; only Ft-bit position
- 1 = report bit errors in Fs-bit position as well as Ft-bit position

Bit 1: Multiframe Out of Sync Count Register Function Select (MOSCRF) (T1 Mode Only).

- 0 = count errors in the framing bit position
- 1 = count the number of multiframe out of sync

Bit 0: T1 Line Code Violation Count Register Function Select (LCVCRF).

- 0 = do not count excessive zeros
- 1 = count excessive zeros

Register Name: **RHFC**
 Register Description: **Receive HDLC FIFO Control Register**
 Register Address: **087h + (200h x n): where n = 0 to 3, for Ports 1 to 4**

Bit #	7	6	5	4	3	2	1	0
Name	—	—	—	—	—	—	RFHWM1	RFHWM0
Default	0	0	0	0	0	0	0	0

Bits 1 and 0: Receive FIFO High Watermark Select (RFHWM[1:0]).

RFHWM1	RFHWM0	RECEIVE FIFO WATERMARK (BYTES)
0	0	4
0	1	16
1	0	32
1	1	48

Register Name: **RIBOC**
 Register Description: **Receive Interleave Bus Operation Control Register**
 Register Address: **088h + (200h x n): where n = 0 to 3, for Ports 1 to 4**

Bit #	7	6	5	4	3	2	1	0
Name	—	IBS1	IBS0	IBOSEL	IBOEN	DA2	DA1	DA0
Default	0	0	0	0	0	0	0	0

Bits 6 and 5: IBO Bus Size Bits (IBS[1:0]). Indicates how many devices on the bus.

IBS1	IBS0	BUS SIZE
0	0	2 devices on bus (4.096MHz)
0	1	4 devices on bus (8.192MHz)
1	0	8 devices on bus (16.384MHz)
1	1	Reserved for future use

Bit 4: Interleave Bus Operation Select (IBOSEL). This bit selects channel or frame interleave mode.
 0 = Channel Interleave
 1 = Frame Interleave

Bit 3: Interleave Bus Operation Enable (IBOEN).
 0 = interleave bus operation disabled
 1 = interleave bus operation enabled

Bits 2 to 0: Device Assignment Bits (DA[2:0]).

DA2	DA1	DA0	DEVICE POSITION
0	0	0	1st device on bus
0	0	1	2nd device on bus
0	1	0	3rd device on bus
0	1	1	4th device on bus
1	0	0	5th device on bus
1	0	1	6th device on bus
1	1	0	7th device on bus
1	1	1	8th device on bus

Register Name: **T1RSCC (T1 Mode Only)**
 Register Description: **In-Band Receive Spare Control Register**
 Register Address: **089h + (200h x n): where n = 0 to 3, for Ports 1 to 4**

Bit #	7	6	5	4	3	2	1	0
Name	—	—	—	—	—	RSC2	RSC1	RSC0
Default	0	0	0	0	0	0	0	0

Bits 2 to 0: Receive Spare Code Length Definition Bits (RSC[2:0]).

RSC2	RSC1	RSC0	LENGTH SELECTED (BITS)
0	0	0	1
0	0	1	2
0	1	0	3
0	1	1	4
1	0	0	5
1	0	1	6
1	1	0	7
1	1	1	8:16

Register Name: **RXPC**
 Register Description: **Receive Expansion Port Control Register**
 Register Address: **08Ah + (200h x n): where n = 0 to 3, for Ports 1 to 4**

Bit #	7	6	5	4	3	2	1	0
Name	—	—	—	—	—	RBPDIR	RBPFUS	RBPEN
Default	0	0	0	0	0	0	0	0

Bit 2: Receive BERT Port Direction Control (RBPDIR).

0 = Normal (line) operation. Receive BERT port receives data from the receive framer.

1 = System (backplane) operation. Receive BERT port receives data from the transmit path. The transmit path enters the receive BERT on the line side of the elastic store (if enabled).

Bit 1: Receive BERT Port Framed/Unframed Select (RBPFUS) (T1 Mode Only).

0 = The receive BERT will *not* clock data from the F-bit position (framed).

1 = The receive BERT will clock data from the F-bit position (unframed).

Bit 0: Receive BERT Port Enable (RBPEN).

0 = Receive BERT port is not active.

1 = Receive BERT port is active.

Register Name: **RBPBS**
 Register Description: **Receive BERT Port Bit Suppress Register**
 Register Address: **08Bh + (200h x n): where n = 0 to 3, for Ports 1 to 4**

Bit #	7	6	5	4	3	2	1	0
Name	BPBSE8	BPBSE7	BPBSE6	BPBSE5	BPBSE4	BPBSE3	BPBSE2	BPBSE1
Default	0	0	0	0	0	0	0	0

Bit 7: Receive Channel Bit 8 Suppress (BPBSE8). MSB of the channel. Set to one to stop this bit from being used.

Bit 6: Receive Channel Bit 7 Suppress (BPBSE7). Set to one to stop this bit from being used.

Bit 5: Receive Channel Bit 6 Suppress (BPBSE6). Set to one to stop this bit from being used.

Bit 4: Receive Channel Bit 5 Suppress (BPBSE5). Set to one to stop this bit from being used.

Bit 3: Receive Channel Bit 4 Suppress (BPBSE4). Set to one to stop this bit from being used.

Bit 2: Receive Channel Bit 3 Suppress (BPBSE3). Set to one to stop this bit from being used.

Bit 1: Receive Channel Bit 2 Suppress (BPBSE2). Set to one to stop this bit from being used.

Bit 0: Receive Channel Bit 1 Suppress (BPBSE1). LSB of the channel. Set to one to stop this bit from being used.

Register Name: **RLS1**
 Register Description: **Receive Latched Status Register 1**
 Register Address: **090h + (200h x n): where n = 0 to 3, for Ports 1 to 4**

Bit #	7	6	5	4	3	2	1	0
Name	RRAIC	RAISC	RLOSC	RLOFC	RRAID	RAISD	RLOSD	RLOFD
Default	0	0	0	0	0	0	0	0

Note: All bits in this register are latched and can create interrupts.

Bit 7: Receive Remote Alarm Indication Condition Clear (RRAIC). Falling edge detect of RRAI. Set when a RRAI condition has cleared.

Bit 6: Receive Alarm Indication Signal Condition Clear (RAISC). Falling edge detect of RAIS. Set when a RAIS condition has cleared.

Bit 5: Receive Loss of Signal Condition Clear (RLOSC). Falling edge detect of RLOS. Set when an RLOS condition has cleared.

Bit 4: Receive Loss of Frame Condition Clear (RLOFC). Falling edge detect of RLOF. Set when an RLOF condition has cleared.

Bit 3: Receive Remote Alarm Indication Condition Detect (RRAID). Rising edge detect of RRAI. Set when a remote alarm is received at RTIP and RRING.

Bit 2: Receive Alarm Indication Signal Condition Detect (RAISD). Rising edge detect of RAIS. Set when an unframed all-ones code is received at RTIP and RRING.

Bit 1: Receive Loss of Signal Condition Detect (RLOSD). Rising edge detect of RLOS. Set when 192 consecutive zeros have been detected at RTIP and RRING.

Bit 0: Receive Loss of Frame Condition Detect (RLOFD). Rising edge detect of RLOF. Set when the DS26524 has lost synchronized to the received data stream.

Register Name: **RLS2 (T1 Mode)**
 Register Description: **Receive Latched Status Register 2**
 Register Address: **091h + (200h x n): where n = 0 to 3, for Ports 1 to 4**

Bit #	7	6	5	4	3	2	1	0
Name	RPDV	—	COFA	8ZD	16ZD	SEFE	B8ZS	FBE
Default	0	0	0	0	0	0	0	0

Note: All bits in these register are latched. This register does not create interrupts. See [RLS2](#) for E1 mode.

Bit 7: Receive Pulse Density Violation Event (RPDV). Set when the receive data stream does not meet the ANSI T1.403 requirements for pulse density.

Bit 5: Change of Frame Alignment Event (COFA). Set when the last resync resulted in a change of frame or multiframe alignment.

Bit 4: Eight Zero Detect Event (8ZD). Set when a string of at least eight consecutive zeros (regardless of the length of the string) have been received.

Bit 3: Sixteen Zero Detect Event (16ZD). Set when a string of at least 16 consecutive zeros (regardless of the length of the string) have been received.

Bit 2: Severely Errored Framing Event (SEFE). Set when two out of six framing bits (Ft or FPS) are received in error.

Bit 1: B8ZS Codeword Detect Event (B8ZS). Set when a B8ZS codeword is detected at RTIP and RRING independent of whether the B8ZS mode is selected or not. Useful for automatically setting the line coding.

Bit 0: Frame Bit Error Event (FBE). Set when a Ft (D4) or FPS (ESF) framing bit is received in error.

Register Name: **RLS2 (E1 Mode)**
 Register Description: **Receive Latched Status Register 2**
 Register Address: **091h + (200h x n): where n = 0 to 3, for Ports 1 to 4**

Bit #	7	6	5	4	3	2	1	0
Name	—	CRCRC	CASRC	FASRC	RSA1	RSA0	RCMF	RAF
Default	0	0	0	0	0	0	0	0

Note: All bits in this register are latched. Bits 0 to 3 can cause interrupts. There is no associated real-time register. See [RLS2](#) for T1 mode.

Bit 6: CRC Resync Criteria Met Event (CRCRC). Set when 915:1000 codewords are received in error.

Bit 5: CAS Resync Criteria Met Event (CASRC). Set when two consecutive CAS MF alignment words are received in error.

Bit 4: FAS Resync Criteria Met Event (FASRC). Set when three consecutive FAS words are received in error.

Bit 3: Receive-Signaling All-Ones Event (RSA1). Set when the contents of time slot 16 contains fewer than three zeros over 16 consecutive frames. This alarm is not disabled in the CCS signaling mode.

Bit 2: Receive-Signaling All-Zeros Event (RSA0). Set when over a full MF, time slot 16 contains all zeros.

Bit 1: Receive CRC-4 Multiframe Event (RCMF). Set on CRC-4 multiframe boundaries. This bit continues to be set every 2ms on an arbitrary boundary if CRC-4 is disabled.

Bit 0: Receive Align Frame Event (RAF). Set approximately every 250 μ s to alert the host that Si and Sa bits are available in the RAF and RNAF registers.

Register Name: **RLS3 (T1 Mode)**
 Register Description: **Receive Latched Status Register 3**
 Register Address: **092h + (200h x n): where n = 0 to 3, for Ports 1 to 4**

Bit #	7	6	5	4	3	2	1	0
Name	LORCC	LSPC	LDNC	LUPC	LORCD	LSPD	LDND	LUPD
Default	0	0	0	0	0	0	0	0

Note: All bits in this register are latched and can create interrupts. See [RLS3](#) for E1 mode.

Bit 7: Loss of Receive Clock Condition Clear (LORCC). Falling edge detect of LORC. Set when an LORC condition was detected and then removed.

Bit 6: Spare Code Detected Condition Clear (LSPC). Falling edge detect of LSP. Set when a spare-code match condition was detected and then removed.

Bit 5: Loop-Down Code Detected Condition Clear (LDNC). Falling edge detect of LDN. Set when a loop-down condition was detected and then removed.

Bit 4: Loop-Up Code Detected Condition Clear (LUPC). Falling edge detect of LUP. Set when a loop-up condition was detected and then removed.

Bit 3: Loss of Receive Clock Condition Detect (LORCD). Rising edge detect of LORC. Set when the RCLK pin has not transitioned for one channel time.

Bit 2: Spare Code Detected Condition Detect (LSPD). Rising edge detect of LSP. Set when the spare code as defined in the [T1RSCD1:T1RSCD2](#) registers is being received.

Bit 1: Loop-Down Code Detected Condition Detect (LDND). Rising edge detect of LDN. Set when the loop-down code as defined in the [T1RDNCD1:T1RDNCD2](#) register is being received.

Bit 0: Loop-Up Code Detected Condition Detect (LUPD). Rising edge detect of LUP. Set when the loop-up code as defined in the [T1RUPCD1:T1RUPCD2](#) register is being received.

Register Name: **RLS3 (E1 Mode)**
 Register Description: **Receive Latched Status Register 3**
 Register Address: **092h + (200h x n): where n = 0 to 3, for Ports 1 to 4**

Bit #	7	6	5	4	3	2	1	0
Name	LORCC	—	V52LNKC	RDMAC	LORCD	—	V52LNKD	RDMAD
Default	0	0	0	0	0	0	0	0

Note: All bits in this register are latched and can create interrupts. See [RLS3](#) for T1 mode.

Bit 7: Loss of Receive Clock Clear (LORCC). Change of state indication. Set when an LORC condition has cleared (falling edge detect of LORC)

Bit 5: V5.2 Link Detected Clear (V52LNKC). Change of state indication. Set when a V52LNK condition has cleared (falling edge detect of V52LNK).

Bit 4: Receive Distant MF Alarm Clear (RDMAC). Change of state indication. Set when an RDMA condition has cleared (falling edge detect of RDMA).

Bit 3: Loss of Receive Clock Detect (LORCD). Change of state indication. Set when the RCLK pin has not transitioned for one channel time (rising edge detect of LORC).

Bit 1: V5.2 Link Detect (V52LNKD). Change of state indication. Set on detection of a V5.2 link identification signal. (G.965). This is the rising edge detect of V52LNK.

Bit 0: Receive Distant MF Alarm Detect (RDMAD). Change of state indication. Set when bit 6 of time slot 16 in frame 0 has been set for two consecutive multiframes. This alarm is not disabled in the CCS signaling mode. This is the rising edge detect of RDMA.

Register Name: **RLS4**
 Register Description: **Receive Latched Status Register 4**
 Register Address: **093h + (200h x n): where n = 0 to 3, for Ports 1 to 4**

Bit #	7	6	5	4	3	2	1	0
Name	RESF	RESEM	RSLIP	—	RSCOS	1SEC	TIMER	RMF
Default	0	0	0	0	0	0	0	0

Note: All bits in this register are latched and can create interrupts.

Bit 7: Receive Elastic Store Full Event (RESF). Set when the receive elastic store buffer fills and a frame is deleted.

Bit 6: Receive Elastic Store Empty Event (RESEM). Set when the receive elastic store buffer empties and a frame is repeated.

Bit 5: Receive Elastic Store Slip Occurrence Event (RSLIP). Set when the receive elastic store has either repeated or deleted a frame.

Bit 3: Receive-Signaling Change-of-State Event (RSCOS). Set when any channel selected by the Receive-Signaling Change-of-State Interrupt Enable registers ([RSCSE1](#):RSCSE3) changes signaling state.

Bit 2: One-Second Timer (1SEC). Set on every one-second interval based on RCLK.

Bit 1: Timer Event (TIMER). This status bit indicates that the performance monitor counters have been updated and are available to be read by the host. The error counter update interval as determined by the settings in the Error Counter Configuration register ([ERCNT](#)).

T1 Mode: Set on increments of one second or 42ms based on RCLK, or a manual latch event.

E1 Mode: Set on increments of one second or 62.5ms based on RCLK, or a manual latch event.

Bit 0: Receive Multiframe Event (RMF).

T1 Mode: Set every 1.5ms on D4 MF boundaries or every 3ms on ESF MF boundaries.

E1 Mode: Set every 2.0ms on receive CAS multiframe boundaries to alert host the signaling data is available. Continues to set on an arbitrary 2.0ms boundary when CAS signaling is not enabled.

Register Name: **RLS5**
 Register Description: **Receive Latched Status Register 5 (HDLC)**
 Register Address: **094h + (200h x n): where n = 0 to 3, for Ports 1 to 4**

Bit #	7	6	5	4	3	2	1	0
Name	—	—	ROVR	RHOBT	RPE	RPS	RHWMS	RNES
Default	0	0	0	0	0	0	0	0

Note: All bits in this register are latched and can cause interrupts.

Bit 5: Receive FIFO Overrun (ROVR). Set when the receive HDLC controller has terminated packet reception because the FIFO buffer is full.

Bit 4: Receive HDLC Opening Byte Event (RHOBT). Set when the next byte available in the receive FIFO is the first byte of a message.

Bit 3: Receive Packet-End Event (RPE). Set when the HDLC controller detects either the finish of a valid message (i.e., CRC check complete) or when the controller has experienced a message fault such as a CRC checking error, or an overrun condition, or an abort has been seen. This is a latched bit and will be cleared when read.

Bit 2: Receive Packet-Start Event (RPS). Set when the HDLC controller detects an opening byte. This is a latched bit and will be cleared when read.

Bit 1: Receive FIFO Above High Watermark Set Event (RHWMS). Set when the receive 64-byte FIFO crosses the high watermark as defined by the Receive HDLC FIFO Control register ([RHFC](#)). Rising edge detect of RHWM.

Bit 0: Receive FIFO Not Empty Set Event (RNES). Set when the receive FIFO has transitioned from empty to not empty (at least one byte has been put into the FIFO). Rising edge detect of RNE.

Register Name: **RLS7 (T1 Mode)**
 Register Description: **Receive Latched Status Register 7**
 Register Address: **096h + (200h x n): where n = 0 to 3, for Ports 1 to 4**

Bit #	7	6	5	4	3	2	1	0
Name	—	—	RRAI-CI	RAIS-CI	RSLC96	RFDLF	BC	BD
Default	0	0	0	0	0	0	0	0

Note: All bits in this register are latched and can create interrupts. See [RLS7](#) for E1 mode.

Bit 5: Receive RAI-CI Detect (RRAI-CI). Set when an RAI-CI pattern has been detected by the receiver. This bit is active in ESF framing mode only, and will set only if an RAI condition is being detected ([RRTS1.3](#)). When the host reads (and clears) this bit, it will set again each time the RAI-CI pattern is detected (approximately every 1.1 seconds).

Bit 4: Receive AIS-CI Detect (RAIS-CI). Set when an AIS-CI pattern has been detected by the receiver. This bit will set only if an AIS condition is being detected ([RRTS1.2](#)). This is a latched bit that must be cleared by the host, and will set again each time the AIS-CI pattern is detected (approximately every 1.2 seconds).

Bit 3: Receive SLC-96 Alignment Event (RSLC96). Set when a valid SLC-96 alignment pattern is detected in the Fs-bit stream, and the RSLCx registers have data available for retrieval. See Section [8.9.4.5](#) for more information.

Bit 2: Receive FDL Register Full Event (RFDLF). Set when the 8-bit [T1RFDL](#) register is full. Useful for SLC-96 operation, or manual extraction of FDL data bits. See Section [8.9.5.4](#) for more information.

Bit 1: BOC Clear Event (BC). Set when a valid BOC is no longer detected (with the disintegration filter applied).

Bit 0: BOC Detect Event (BD). Set when a valid BOC has been detected (with the BOC filter applied).

Register Name: **RLS7 (E1 Mode)**
 Register Description: **Receive Latched Status Register 7**
 Register Address: **096h + (200h x n): where n = 0 to 3, for Ports 1 to 4**

Bit #	7	6	5	4	3	2	1	0
Name	—	—	—	—	—	—	Sa6CD	SaXCD
Default	0	0	0	0	0	0	0	0

Note: All bits in this register are latched and can create interrupts. See [RLS7](#) for T1 mode.

Bit 1: Sa6 Codeword Detect (Sa6CD). Set when a valid codeword (per ETS 300 233) is detected in the Sa6 bit positions.

Bit 0: SaX Bit Change Detect (SaXCD). Set when a bit change is detected in the SaX bit position. The enabled SaX bits are selected by the [E1RSAIMR](#) register.

Register Name: **RSS1, RSS2, RSS3, RSS4**
 Register Description: **Receive-Signaling Status Registers 1 to 4**
 Register Address: **098h, 099h, 09Ah, 09Bh + (200h x n): where n = 0 to 3, for Ports 1 to 4**

Bit #	(MSB) 7	6	5	4	3	2	1	0 (LSB)	
Name	CH8	CH7	CH6	CH5	CH4	CH3	CH2	CH1*	RSS1
	CH16	CH15	CH14	CH13	CH12	CH11	CH10	CH9	RSS2
	CH24	CH23	CH22	CH21	CH20	CH19	CH18	CH17*	RSS3
	CH32	CH31	CH30	CH29	CH28	CH27	CH26	CH25	RSS4
Default	0	0	0	0	0	0	0	0	(E1 Mode Only)

Note: Status bits in this register are latched.

When a channel's signaling data changes state, the respective bit in registers [RSS1:RSS4](#) will be set and latched. The RSCOS bit ([RLS4.3](#)) will be set if the channel was also enabled by setting the appropriate bit in [RSCSE1:4](#). The $\overline{\text{INTB}}$ signal will go low if enabled by the interrupt mask bit [RIM4.3](#). The bit will remain set until read.

*Note that in E1 CAS mode, the LSB of RSS1 would typically represent the CAS alignment bits, and the LSB of [RSS3](#) represents reserved bits and the distant multiframe alarm.

Register Name: **T1RSCD1 (T1 Mode Only)**
 Register Description: **Receive Spare Code Definition Register 1**
 Register Address: **09Ch + (200h x n): where n = 0 to 3, for Ports 1 to 4**

Bit #	7	6	5	4	3	2	1	0
Name	C7	C6	C5	C4	C3	C2	C1	C0
Default	0	0	0	0	0	0	0	0

Note: Writing this register resets the detector's integration period.

Bit 7: Receive Spare Code Definition Bit 7 (C7). First bit of the repeating pattern.

Bit 6: Receive Spare Code Definition Bit 6 (C6). A Don't Care if a 1-bit length is selected.

Bit 5: Receive Spare Code Definition Bit 5 (C5). A Don't Care if a 1- or 2-bit length is selected.

Bit 4: Receive Spare Code Definition Bit 4 (C4). A Don't Care if a 1- to 3-bit length is selected.

Bit 3: Receive Spare Code Definition Bit 3 (C3). A Don't Care if a 1- to 4-bit length is selected.

Bit 2: Receive Spare Code Definition Bit 2 (C2). A Don't Care if a 1- to 5-bit length is selected.

Bit 1: Receive Spare Code Definition Bit 1 (C1). A Don't Care if a 1- to 6-bit length is selected.

Bit 0: Receive Spare Code Definition Bit 0 (C0). A Don't Care if a 1- to 7-bit length is selected.

Register Name: **T1RSCD2 (T1 Mode Only)**
 Register Description: **Receive Spare Code Definition Register 2**
 Register Address: **09Dh + (200h x n): where n = 0 to 3, for Ports 1 to 4**

Bit #	7	6	5	4	3	2	1	0
Name	C7	C6	C5	C4	C3	C2	C1	C0
Default	0	0	0	0	0	0	0	0

Bit 7: Receive Spare Code Definition Bit 7 (C7). A Don't Care if a 1- to 7-bit length is selected.

Bit 6: Receive Spare Code Definition Bit 6 (C6). A Don't Care if a 1- to 7-bit length is selected.

Bit 5: Receive Spare Code Definition Bit 5 (C5). A Don't Care if a 1- to 7-bit length is selected.

Bit 4: Receive Spare Code Definition Bit 4 (C4). A Don't Care if a 1- to 7-bit length is selected.

Bit 3: Receive Spare Code Definition Bit 3 (C3). A Don't Care if a 1- to 7-bit length is selected.

Bit 2: Receive Spare Code Definition Bit 2 (C2). A Don't Care if a 1- to 7-bit length is selected.

Bit 1: Receive Spare Code Definition Bit 1 (C1). A Don't Care if a 1- to 7-bit length is selected.

Bit 0: Receive Spare Code Definition Bit 0 (C0). A Don't Care if a 1- to 7-bit length is selected.

Register Name: **RIIR**
 Register Description: **Receive Interrupt Information Register**
 Register Address: **09Fh + (200h x n): where n = 0 to 3, for Ports 1 to 4**

Bit #	7	6	5	4	3	2	1	0
Name	—	RLS7	RLS6*	RLS5	RLS4	RLS3	RLS2**	RLS1
Default	0	0	0	0	0	0	0	0

*RLS6 is reserved for future use.

**Currently, RLS2 does not create an interrupt, therefore this bit is not used in T1 mode.

The Receive Interrupt Information register ([RIIR](#)) indicates which of the DS26524 status registers are generating an interrupt. When an interrupt occurs, the host can read RIIR to quickly identify which of the receive status registers is (are) causing the interrupt(s). The RIIR bits clear once the appropriate interrupt has been serviced and cleared, as long as no additional, unmasked interrupt condition is present in the associated status register. Status bits that have been masked via the Receive Interrupt Mask (RIMx) registers will also be masked from the RIIR register.

Register Name: **RIM1**
 Register Description: **Receive Interrupt Mask Register 1**
 Register Address: **0A0h + (200h x n): where n = 0 to 3, for Ports 1 to 4**

Bit #	7	6	5	4	3	2	1	0
Name	RRAIC	RAISC	RLOSC	RLOFC	RRAID	RAISD	RLOSD	RLOFD
Default	0	0	0	0	0	0	0	0

Bit 7: Receive Remote Alarm Indication Condition Clear (RRAIC).

0 = interrupt masked
 1 = interrupt enabled

Bit 6: Receive Alarm Indication Signal Condition Clear (RAISC).

0 = interrupt masked
 1 = interrupt enabled

Bit 5: Receive Loss of Signal Condition Clear (RLOSC).

0 = interrupt masked
 1 = interrupt enabled

Bit 4: Receive Loss of Frame Condition Clear (RLOFC).

0 = interrupt masked
 1 = interrupt enabled

Bit 3: Receive Remote Alarm Indication Condition Detect (RRAID).

0 = interrupt masked
 1 = interrupt enabled

Bit 2: Receive Alarm Indication Signal Condition Detect (RAISD).

0 = interrupt masked
 1 = interrupt enabled

Bit 1: Receive Loss of Signal Condition Detect (RLOSD).

0 = interrupt masked
 1 = interrupt enabled

Bit 0: Receive Loss of Frame Condition Detect (RLOFD).

0 = interrupt masked
 1 = interrupt enabled

Register Name: **RIM2 (E1 Mode Only)**
 Register Description: **Receive Interrupt Mask Register 2**
 Register Address: **0A1h + (200h x n): where n = 0 to 3, for Ports 1 to 4**

Bit #	7	6	5	4	3	2	1	0
Name	—	—	—	—	RSA1	RSA0	RCMF	RAF
Default	0	0	0	0	0	0	0	0

Bit 3: Receive-Signaling All-Ones Event (RSA1).

0 = interrupt masked
 1 = interrupt enabled

Bit 2: Receive-Signaling All-Zeros Event (RSA0).

0 = interrupt masked
 1 = interrupt enabled

Bit 1: Receive CRC-4 Multiframe Event (RCMF).

0 = interrupt masked
 1 = interrupt enabled

Bit 0: Receive Align Frame Event (RAF).

0 = interrupt masked
 1 = interrupt enabled

Register Name: **RIM3 (T1 Mode)**
 Register Description: **Receive Interrupt Mask Register 3**
 Register Address: **0A2h + (200h x n): where n = 0 to 3, for Ports 1 to 4**

Bit #	7	6	5	4	3	2	1	0
Name	LORCC	LSPC	LDNC	LUPC	LORCD	LSPD	LDND	LUPD
Default	0	0	0	0	0	0	0	0

Note: For E1 mode, see [RIM3](#).

Bit 7: Loss of Receive Clock Condition Clear (LORCC).

0 = interrupt masked
 1 = interrupt enabled

Bit 6: Spare Code Detected Condition Clear (LSPC).

0 = interrupt masked
 1 = interrupt enabled

Bit 5: Loop-Down Code Detected Condition Clear (LDNC).

0 = interrupt masked
 1 = interrupt enabled

Bit 4: Loop-Up Code Detected Condition Clear (LUPC).

0 = interrupt masked
 1 = interrupt enabled

Bit 3: Loss of Receive Clock Condition Detect (LORCD).

0 = interrupt masked
 1 = interrupt enabled

Bit 2: Spare Code Detected Condition Detect (LSPD).

0 = interrupt masked
 1 = interrupt enabled

Bit 1: Loop-Down Code Detected Condition Detect (LDND).

0 = interrupt masked
 1 = interrupt enabled

Bit 0: Loop-Up Code Detected Condition Detect (LUPD).

0 = interrupt masked
 1 = interrupt enabled

Register Name: **RIM3 (E1 Mode)**
 Register Description: **Receive Interrupt Mask Register 3**
 Register Address: **0A2h + (200h x n): where n = 0 to 3, for Ports 1 to 4**

Bit #	7	6	5	4	3	2	1	0
Name	LORCC	—	V52LNKC	RDMAC	LORCD	—	V52LNKD	RDMAD
Default	0	0	0	0	0	0	0	0

Note: For T1 mode, see [RIM3](#).

Bit 7: Loss of Receive Clock Clear (LORCC).

0 = interrupt masked
 1 = interrupt enabled

Bit 5: V5.2 Link Detected Clear (V52LNKC).

0 = interrupt masked
 1 = interrupt enabled

Bit 4: Receive Distant MF Alarm Clear (RDMAC).

0 = interrupt masked
 1 = interrupt enabled

Bit 3: Loss of Receive Clock Detect (LORCD).

0 = interrupt masked
 1 = interrupt enabled

Bit 1: V5.2 Link Detect (V52LNKD).

0 = interrupt masked
 1 = interrupt enabled

Bit 0: Receive Distant MF Alarm Detect (RDMAD).

0 = interrupt masked
 1 = interrupt enabled

Register Name: **RIM4**
 Register Description: **Receive Interrupt Mask Register 4**
 Register Address: **0A3h + (200h x n): where n = 0 to 3, for Ports 1 to 4**

Bit #	7	6	5	4	3	2	1	0
Name	RESF	RESEM	RSLIP	—	RSCOS	1SEC	TIMER	RMF
Default	0	0	0	0	0	0	0	0

Bit 7: Receive Elastic Store Full Event (RESF).

0 = interrupt masked
 1 = interrupt enabled

Bit 6: Receive Elastic Store Empty Event (RESEM).

0 = interrupt masked
 1 = interrupt enabled

Bit 5: Receive Elastic Store Slip Occurrence Event (RSLIP).

0 = interrupt masked
 1 = interrupt enabled

Bit 3: Receive-Signaling Change-of-State Event (RSCOS).

0 = interrupt masked
 1 = interrupt enabled

Bit 2: One-Second Timer (1SEC).

0 = interrupt masked
 1 = interrupt enabled

Bit 1: Timer Event (TIMER).

0 = interrupt masked
 1 = interrupt enabled

Bit 0: Receive Multiframe Event (RMF).

0 = interrupt masked
 1 = interrupt enabled

Register Name: **RIM5**
 Register Description: **Receive Interrupt Mask Register 5 (HDLC)**
 Register Address: **0A4h + (200h x n): where n = 0 to 3, for Ports 1 to 4**

Bit #	7	6	5	4	3	2	1	0
Name	—	—	ROVR	RHOBT	RPE	RPS	RHWMS	RNES
Default	0	0	0	0	0	0	0	0

Bit 5: Receive FIFO Overrun (ROVR).

0 = interrupt masked
 1 = interrupt enabled

Bit 4: Receive HDLC Opening Byte Event (RHOBT).

0 = interrupt masked
 1 = interrupt enabled

Bit 3: Receive Packet-End Event (RPE).

0 = interrupt masked
 1 = interrupt enabled

Bit 2: Receive Packet-Start Event (RPS).

0 = interrupt masked
 1 = interrupt enabled

Bit 1: Receive FIFO Above High Watermark Set Event (RHWMS).

0 = interrupt masked
 1 = interrupt enabled

Bit 0: Receive FIFO Not Empty Set Event (RNES).

0 = interrupt masked
 1 = interrupt enabled

Register Name: **RIM7 (T1 Mode)**
 Register Description: **Receive Interrupt Mask Register 7 (BOC:FDL)**
 Register Address: **0A6h + (200h x n): where n = 0 to 3, for Ports 1 to 4**

Bit #	7	6	5	4	3	2	1	0
Name	—	—	RRAI-CI	RAIS-CI	RSLC96	RFDLF	BC	BD
Default	0	0	0	0	0	0	0	0

Note: For E1 mode, see [RIM7](#).

Bit 5: Receive RAI-CI (RRAI-CI).

0 = interrupt masked
 1 = interrupt enabled

Bit 4: Receive AIS-CI (RAIS-CI).

0 = interrupt masked
 1 = interrupt enabled

Bit 3: Receive SLC-96 (RSLC96).

0 = interrupt masked
 1 = interrupt enabled

Bit 2: Receive FDL Register Full (RFDLF).

0 = interrupt masked
 1 = interrupt enabled

Bit 1: BOC Clear Event (BC).

0 = interrupt masked
 1 = interrupt enabled

Bit 0: BOC Detect Event (BD).

0 = interrupt masked
 1 = interrupt enabled

Register Name: **RIM7 (E1 Mode)**
 Register Description: **Receive Interrupt Mask Register 7 (BOC:FDL)**
 Register Address: **A6h + (200h x n): where n = 0 to 3, for Ports 1 to 4**

Bit #	7	6	5	4	3	2	1	0
Name	—	—	—	—	—	—	Sa6CD	SaXCD
Default	0	0	0	0	0	0	0	0

Note: For T1 mode, see [RIM7](#).

Bit 1: Sa6 Codeword Detect. This bit will enable the interrupt generated when a valid codeword (per ETS 300 233) is detected in the Sa6 bits.

0 = interrupt masked
 1 = interrupt enabled

Bit 0: SaX Change Detect. This bit will enable the interrupt generated when a change of state is detected in any of the unmasked SaX bit positions. The masked or unmasked SaX bits are selected by the [E1RSAIMR](#) register.

0 = interrupt masked
 1 = interrupt enabled

Register Name: **RSCSE1, RSCSE2, RSCSE3, RSCSE4**
 Register Description: **Receive-Signaling Change of State Enable Registers 1 to 4**
 Register Address: **0A8h, 0A9h, 0AAh, 0Abh + (200h x n): where n = 0 to 3, for Ports 1 to 4**

Bit #	(MSB) 7	6	5	4	3	2	1	0 (LSB)	
Name	CH8	CH7	CH6	CH5	CH4	CH3	CH2	CH1	RSCSE1
	CH16	CH15	CH14	CH13	CH12	CH11	CH10	CH9	RSCSE2
	CH24	CH23	CH22	CH21	CH20	CH19	CH18	CH17	RSCSE3
	<i>CH32</i>	<i>CH31</i>	<i>CH30</i>	<i>CH29</i>	<i>CH28</i>	<i>CH27</i>	<i>CH26</i>	<i>CH25</i>	RSCSE4 (E1 Mode Only)
Default	0	0	0	0	0	0	0	0	

Setting any of the CH[1:32] bits in the RSCSE1:RSCSE4 registers will cause RSCOS ([RLS4.3](#)) to be set when that channel's signaling data changes state.

Register Name: **T1RUPCD1 (T1 Mode Only)**
 Register Description: **Receive Up Code Definition Register 1**
 Register Address: **0ACh + (200h x n): where n = 0 to 3, for Ports 1 to 4**

Bit #	7	6	5	4	3	2	1	0
Name	C7	C6	C5	C4	C3	C2	C1	C0
Default	0	0	0	0	0	0	0	0

Note: Writing this register resets the detector's integration period.

Bit 7: Receive Up Code Definition Bit 7 (C7). First bit of the repeating pattern.

Bit 6: Receive Up Code Definition Bit 6 (C6). A Don't Care if a 1-bit length is selected.

Bit 5: Receive Up Code Definition Bit 5 (C5). A Don't Care if a 1- or 2-bit length is selected.

Bit 4: Receive Up Code Definition Bit 4 (C4). A Don't Care if a 1- to 3-bit length is selected.

Bit 3: Receive Up Code Definition Bit 3 (C3). A Don't Care if a 1- to 4-bit length is selected.

Bit 2: Receive Up Code Definition Bit 2 (C2). A Don't Care if a 1- to 5-bit length is selected.

Bit 1: Receive Up Code Definition Bit 1 (C1). A Don't Care if a 1- to 6-bit length is selected.

Bit 0: Receive Up Code Definition Bit 0 (C0). A Don't Care if a 1- to 7-bit length is selected.

Register Name: **T1RUPCD2 (T1 Mode Only)**
 Register Description: **Receive Up Code Definition Register 2**
 Register Address: **0ADh + (200h x n): where n = 0 to 3, for Ports 1 to 4**

Bit #	7	6	5	4	3	2	1	0
Name	C7	C6	C5	C4	C3	C2	C1	C0
Default	0	0	0	0	0	0	0	0

Bit 7: Receive Up Code Definition Bit 7 (C7). A Don't Care if a 1- to 7-bit length is selected.

Bit 6: Receive Up Code Definition Bit 6 (C6). A Don't Care if a 1- to 7-bit length is selected.

Bit 5: Receive Up Code Definition Bit 5 (C5). A Don't Care if a 1- to 7-bit length is selected.

Bit 4: Receive Up Code Definition Bit 4 (C4). A Don't Care if a 1- to 7-bit length is selected.

Bit 3: Receive Up Code Definition Bit 3 (C3). A Don't Care if a 1- to 7-bit length is selected.

Bit 2: Receive Up Code Definition Bit 2 (C2). A Don't Care if a 1- to 7-bit length is selected.

Bit 1: Receive Up Code Definition Bit 1 (C1). A Don't Care if a 1- to 7-bit length is selected.

Bit 0: Receive Up Code Definition Bit 0 (C0). A Don't Care if a 1- to 7-bit length is selected.

Register Name: **T1RDNCD1 (T1 Mode Only)**
 Register Description: **Receive Down Code Definition Register 1**
 Register Address: **0AEh + (200h x n): where n = 0 to 3, for Ports 1 to 4**

Bit #	7	6	5	4	3	2	1	0
Name	C7	C6	C5	C4	C3	C2	C1	C0
Default	0	0	0	0	0	0	0	0

Note: Writing this register resets the detector's integration period.

Bit 7: Receive Down Code Definition Bit 7 (C7). First bit of the repeating pattern.

Bit 6: Receive Down Code Definition Bit 6 (C6). A Don't Care if a 1-bit length is selected.

Bit 5: Receive Down Code Definition Bit 5 (C5). A Don't Care if a 1- or 2-bit length is selected.

Bit 4: Receive Down Code Definition Bit 4 (C4). A Don't Care if a 1- to 3-bit length is selected.

Bit 3: Receive Down Code Definition Bit 3 (C3). A Don't Care if a 1- to 4-bit length is selected.

Bit 2: Receive Down Code Definition Bit 2 (C2). A Don't Care if a 1- to 5-bit length is selected.

Bit 1: Receive Down Code Definition Bit 1 (C1). A Don't Care if a 1- to 6-bit length is selected.

Bit 0: Receive Down Code Definition Bit 0 (C0). A Don't Care if a 1- to 7-bit length is selected.

Register Name: **T1RDNCD2 (T1 Mode Only)**
 Register Description: **Receive Down Code Definition Register 2**
 Register Address: **0AFh + (200h x n): where n = 0 to 3, for Ports 1 to 4**

Bit #	7	6	5	4	3	2	1	0
Name	C7	C6	C5	C4	C3	C2	C1	C0
Default	0	0	0	0	0	0	0	0

Bit 7: Receive Down Code Definition Bit 7 (C7). A Don't Care if a 1- to 7-bit length is selected.

Bit 6: Receive Down Code Definition Bit 6 (C6). A Don't Care if a 1- to 7-bit length is selected.

Bit 5: Receive Down Code Definition Bit 5 (C5). A Don't Care if a 1- to 7-bit length is selected.

Bit 4: Receive Down Code Definition Bit 4 (C4). A Don't Care if a 1- to 7-bit length is selected.

Bit 3: Receive Down Code Definition Bit 3 (C3). A Don't Care if a 1- to 7-bit length is selected.

Bit 2: Receive Down Code Definition Bit 2 (C2). A Don't Care if a 1- to 7-bit length is selected.

Bit 1: Receive Down Code Definition Bit 1 (C1). A Don't Care if a 1- to 7-bit length is selected.

Bit 0: Receive Down Code Definition Bit 0 (C0). A Don't Care if a 1- to 7-bit length is selected.

Register Name: **RRTS1**
 Register Description: **Receive Real-Time Status Register 1**
 Register Address: **0B0h + (200h x n): where n = 0 to 3, for Ports 1 to 4**

Bit #	7	6	5	4	3	2	1	0
Name	—	—	—	—	RRAI	RAIS	RLOS	RLOF
Default	0	0	0	0	0	0	0	0

Note: All bits in this register are real-time (not latched).

Bit 3: Receive Remote Alarm Indication Condition (RRAI). Set when a remote alarm is received at RTIP and RRING.

Bit 2: Receive Alarm Indication Signal Condition (RAIS). Set when an unframed all-ones code is received at RTIP and RRING.

Bit 1: Receive Loss of Signal Condition (RLOS). Set when 192 consecutive zeros have been detected after the B8ZS/HDB3 decoder.

Bit 0: Receive Loss of Frame Condition (RLOF). Set when the DS26524 is not synchronized to the received data stream.

Register Name: **RRTS3 (T1 Mode)**
 Register Description: **Receive Real-Time Status Register 3**
 Register Address: **0B2h + (200h x n): where n = 0 to 3, for Ports 1 to 4**

Bit #	7	6	5	4	3	2	1	0
Name	—	—	—	—	LORC	LSP	LDN	LUP
Default	0	0	0	0	0	0	0	0

Note: All bits in this register are real-time (not latched). See [RRTS3](#) for E1 mode.

Bit 3: Loss of Receive Clock Condition (LORC). Set when the RCLK pin has not transitioned for one channel time.

Bit 2: Spare Code Detected Condition (LSP). Set when the spare code as defined in the [T1RSCD1:T1RSCD2](#) registers is being received.

Bit 1: Loop-Down Code Detected Condition (LDN). Set when the loop-down code as defined in the [T1RDNCD1:T1RDNCD2](#) register is being received.

Bit 0: Loop-Up Code Detected Condition (LUP). Set when the loop-up code as defined in the [T1RUPCD1:T1RUPCD2](#) register is being received.

Register Name: **RRTS3 (E1 Mode)**
 Register Description: **Receive Real-Time Status Register 3**
 Register Address: **0B2h + (200h x n): where n = 0 to 3, for Ports 1 to 4**

Bit #	7	6	5	4	3	2	1	0
Name	—	—	—	—	LORC	—	V52LNK	RDMA
Default	0	0	0	0	0	0	0	0

Note: All bits in this register are real-time (not latched). See [RRTS3](#) for T1 mode.

Bit 3: Loss of Receive Clock Condition (LORC). Set when the RCLK pin has not transitioned for one channel time.

Bit 1: V5.2 Link Detected Condition (V52LNK). Set on detection of a V5.2 link identification signal (G.965).

Bit 0: Receive Distant MF Alarm Condition (RDMA). Set when bit 6 of time slot 16 in frame 0 has been set for two consecutive multiframes. This alarm is not disabled in the CCS signaling mode.

Register Name: **RRTS5**
 Register Description: **Receive Real-Time Status Register 5 (HDLC)**
 Register Address: **0B4h + (200h x n): where n = 0 to 3, for Ports 1 to 4**

Bit #	7	6	5	4	3	2	1	0
Name	—	PS2	PS1	PS0	—	—	RHWM	RNE
Default	0	0	0	0	0	0	0	0

Note: All bits in this register are real time.

Bits 6 to 4: Receive Packet Status (PS[2:0]). These are real-time bits indicating the status as of the last read of the receive FIFO.

PS2	PS1	PS0	PACKET STATUS
0	0	0	In Progress: End of message has not yet been reached.
0	0	1	Packet OK: Packet ended with correct CRC codeword.
0	1	0	CRC Error: A closing flag was detected, preceded by a corrupt CRC codeword.
0	1	1	Abort: Packet ended because an abort signal was detected (7 or more ones in a row).
1	0	0	Overrun: HDLC controller terminated reception of packet because receive FIFO is full.

Bit 1: Receive FIFO Above High Watermark Condition (RHWM). Set when the receive 64-byte FIFO fills beyond the high watermark as defined by the Receive HDLC FIFO Control register (RHFC). This is a real-time bit.

Bit 0: Receive FIFO Not Empty Condition (RNE). Set when the receive 64-byte FIFO has at least one byte available for a read. This is a real-time bit.

Register Name: **RHPBA**
 Register Description: **Receive HDLC Packet Bytes Available Register**
 Register Address: **0B5h + (200h x n): where n = 0 to 3, for Ports 1 to 4**

Bit #	7	6	5	4	3	2	1	0
Name	MS	RPBA6	RPBA5	RPBA4	RPBA3	RPBA2	RPBA1	RPBA0
Default	0	0	0	0	0	0	0	0

Bit 7: Message Status (MS).

0 = Bytes indicated by RPBA[6:0] are the end of a message. Host must check the HDLC status register for details.

1 = Bytes indicated by RPBA[6:0] are the beginning or continuation of a message. The host does not need to check the HDLC status. The MS bit returns to a value of 1 when the Rx HDLC FIFO is empty.

Bits 6 to 0: Receive FIFO Packet Bytes Available Count (RPBA[6:0]). RPBA0 is the LSB.

Register Name: **RHF**
 Register Description: **Receive HDLC FIFO Register**
 Register Address: **0B6h + (200h x n): where n = 0 to 3, for Ports 1 to 4**

Bit #	7	6	5	4	3	2	1	0
Name	RHD7	RHD6	RHD5	RHD4	RHD3	RHD2	RHD1	RHD0
Default	0	0	0	0	0	0	0	0

Bit 7: Receive HDLC Data Bit 7 (RHD7). MSB of a HDLC packet data byte.

Bit 6: Receive HDLC Data Bit 6 (RHD6).

Bit 5: Receive HDLC Data Bit 5 (RHD5).

Bit 4: Receive HDLC Data Bit 4 (RHD4).

Bit 3: Receive HDLC Data Bit 3 (RHD3).

Bit 2: Receive HDLC Data Bit 2 (RHD2).

Bit 1: Receive HDLC Data Bit 1 (RHD1).

Bit 0: Receive HDLC Data Bit 0 (RHD0). LSB of a HDLC packet data byte.

Register Name: **RBCS1, RBCS2, RBCS3, RBCS4**
 Register Description: **Receive Blank Channel Select Registers 1 to 4**
 Register Address: **0C0h, 0C1h, 0C2h, 0C3h + (200h x n): where n = 0 to 3, for Ports 1 to 4**

Bit #	7	6	5	4	3	2	1	0	
Name	CH8	CH7	CH6	CH5	CH4	CH3	CH2	CH1	RBCS1 RBCS2 RBCS3 RBCS4 (E1 Mode Only)
	CH16	CH15	CH14	CH13	CH12	CH11	CH10	CH9	
	CH24	CH23	CH22	CH21	CH20	CH19	CH18	CH17	
	CH32	CH31	CH30	CH29	CH28	CH27	CH26	CH25	
Default	0	0	0	0	0	0	0	0	

Bit 7 to 0: Receive Blank Channel Select for Channels 1 to 32 (CH[1:32]).

0 = Do not blank this channel (channel data is available on RSER)

1 = Data on RSER is forced to all ones for this channel

Note that when two or more sequential channels are chosen to be blanked, the receive-slip zone select bit should be set to 0. If the blank channels are distributed (such as 1, 5, 9, 13, 17, 21, 25, 29), the RSZS bit can be set to 1, which may provide a lower occurrence of slips in certain applications.

Register Name: **RCBR1, RCBR2, RCBR3, RCBR4**
 Register Description: **Receive Channel Blocking Registers 1 to 4**
 Register Address: **0C4h, 0C5h, 0C6h, 0C7h + (200h x n): where n = 0 to 3, for Ports 1 to 4**

Bit #	7	6	5	4	3	2	1	0	
Name	CH8	CH7	CH6	CH5	CH4	CH3	CH2	CH1	RCBR1
	CH16	CH15	CH14	CH13	CH12	CH11	CH10	CH9	RCBR2
	CH24	CH23	CH22	CH21	CH20	CH19	CH18	CH17	RCBR3
	<i>CH32</i>	<i>CH31</i>	<i>CH30</i>	<i>CH29</i>	<i>CH28</i>	<i>CH27</i>	<i>CH26</i>	<i>CH25 (F-bit)</i>	RCBR4* (E1 Mode Only)
Default	0	0	0	0	0	0	0	0	

Bits 7 to 0: Receive Channel Blocking Control Bits for Channels 1 to 32 (CH[1:32]).

0 = force the RCHBLK pin to remain low during this channel time

1 = force the RCHBLK pin high during this channel time

***Note that RCBR4 has two functions:**

When 2.048MHz backplane mode is selected, this register allows the user to enable the channel blocking signal for any of the 32 possible backplane channels.

When 1.544MHz backplane mode is selected, the LSB of this register determines whether or not the RCHBLK signal will pulse high during the F-Bit time. In this mode, [RCBR4.1:RCBR4.7](#) should be set to 0.

[RCBR4.0](#) = 0, do not pulse RCHBLK during the F-bit.

[RCBR4.0](#) = 1, pulse RCHBLK during the F-bit.

Register Name: **RSI1, RSI2, RSI3, RSI4**
 Register Description: **Receive-Signaling Reinsertion Enable Registers 1 to 4**
 Register Address: **0C8h, 0C9h, 0CAh, 0CBh + (200h x n): where n = 0 to 3, for Ports 1 to 4**

Bit #	7	6	5	4	3	2	1	0	
Name	CH8	CH7	CH6	CH5	CH4	CH3	CH2	CH1	RSI1
	CH16	CH15	CH14	CH13	CH12	CH11	CH10	CH9	RSI2
	CH24	CH23	CH22	CH21	CH20	CH19	CH18	CH17	RSI3
	<i>CH32</i>	<i>CH31</i>	<i>CH30</i>	<i>CH29</i>	<i>CH28</i>	<i>CH27</i>	<i>CH26</i>	<i>CH25</i>	RSI4 (E1 Mode Only)
Default	0	0	0	0	0	0	0	0	

Setting any of the CH[1:24] bits in the RSI1:RSI3 registers causes signaling data to be reinserted for the associated channel. RSI4 is used for 2.048MHz backplane operation.

Register Name: **RGCCS1, RGCCS2, RGCCS3, RGCCS4**
 Register Description: **Receive Gapped-Clock Channel Select Registers 1 to 4**
 Register Address: **0CCh, 0CDh, 0CEh, 0CFh + (200h x n): where n = 0 to 3, for Ports 1 to 4**

Bit #	7	6	5	4	3	2	1	0	
Name	CH8	CH7	CH6	CH5	CH4	CH3	CH2	CH1	RGCCS1
	CH16	CH15	CH14	CH13	CH12	CH11	CH10	CH9	RGCCS2
	CH24	CH23	CH22	CH21	CH20	CH19	CH18	CH17	RGCCS3
	CH32	CH31	CH30	CH29	CH28	CH27	CH26	CH25 (F-bit)	RGCCS4* (E1 Mode Only)
Default	0	0	0	0	0	0	0	0	

Bits 7 to 0: Receive Gapped Clock Channel Select Bits for Channels 1 to 32 (CH[1:32]).

0 = no clock is present on RCHCLK during this channel time

1 = force a clock on RCHCLK during this channel time. The clock will be synchronous with RCLK if the elastic store is disabled, and synchronous with RSYCLK if the elastic store is enabled.

***Note that RGCCS4 has two functions:**

When 2.048MHz backplane mode is selected, this register allows the user to enable the gapped clock on RCHCLK for any of the 32 possible backplane channels.

When 1.544MHz backplane mode is selected, the LSB of this register determines whether or not a clock is generated on RCHCLK during the F-bit time:

RGCCS4.0 = 0, do not generate a clock during the F-bit.

RGCCS4.0 = 1, generate a clock during the F-bit.

In this mode, RGCCS4.1:RGCCS4.7 should be set to 0.

Register Name: **RCICE1, RCICE2, RCICE3, RCICE4**
 Register Description: **Receive Channel Idle Code Enable Registers 1 to 4**
 Register Address: **0D0h, 0D1h, 0D2h, 0D3h + (200h x n): where n = 0 to 3, for Ports 1 to 4**

Bit #	(MSB) 7	6	5	4	3	2	1	0 (LSB)	
Name	CH8	CH7	CH6	CH5	CH4	CH3	CH2	CH1	RCICE1
	CH16	CH15	CH14	CH13	CH12	CH11	CH10	CH9	RCICE2
	CH24	CH23	CH22	CH21	CH20	CH19	CH18	CH17	RCICE3
	CH32	CH31	CH30	CH29	CH28	CH27	CH26	CH25	RCICE4 (E1 Mode Only)
Default	0	0	0	0	0	0	0	0	

Bits 7 to 0: Receive Channel Idle Code Insertion Control Bits for Channels 1 to 32 (CH[1:32]).

0 = do not insert data from the Idle Code Array into the receive data stream

1 = insert data from the Idle Code Array into the receive data stream

Register Name: **RBPCS1, RBPCS2, RBPCS3, RBPCS4**
 Register Description: **Receive BERT Port Channel Select Registers 1 to 4**
 Register Address: **0D4h, 0D5h, 0D6h, 0D7h + (200h x n): where n = 0 to 3, for Ports 1 to 4**

Bit #	(MSB) 7	6	5	4	3	2	1	0 (LSB)	
Name	CH8	CH7	CH6	CH5	CH4	CH3	CH2	CH1	RBPCS1
	CH16	CH15	CH14	CH13	CH12	CH11	CH10	CH9	RBPCS2
	CH24	CH23	CH22	CH21	CH20	CH19	CH18	CH17	RBPCS3
	<i>CH32</i>	<i>CH31</i>	<i>CH30</i>	<i>CH29</i>	<i>CH28</i>	<i>CH27</i>	<i>CH26</i>	<i>CH25</i>	RBPCS4 (E1 Mode Only)
Default	0	0	0	0	0	0	0	0	

Bits 7 to 0: BERT Port Channel Select Receive Channels 1 to 32 (CH[1:32]).

0 = Do not enable the receive BERT clock for the associated channel time, or map the selected channel data out of the receive BERT port.

1 = Enable the receive BERT clock for the associated channel time, and allow mapping of the selected channel data out of the receive BERT port. Multiple or all channels may be selected simultaneously.

9.4.2 Transmit Register Definitions

Register Name: **THC1**
 Register Description: **Transmit HDLC Control Register 1**
 Register Address: **110h + (200h x n): where n = 0 to 3, for Ports 1 to 4**

Bit #	7	6	5	4	3	2	1	0
Name	NOFS	TEOML	THR	THMS	TFS	TEOM	TZSD	TCRCD
Default	0	0	0	0	0	0	0	0

Bit 7: Number of Flags Select (NOFS).

- 0 = send one flag between consecutive messages
- 1 = send two flags between consecutive messages

Bit 6: Transmit End of Message and Loop (TEOML). To loop on a message, this bit should be set to a one just before the last data byte of an HDLC packet is written into the transmit FIFO. The message will repeat until the user clears this bit or a new message is written to the transmit FIFO. If the host clears the bit, the looping message will complete then flags will be transmitted until new message is written to the FIFO. If the host terminates the loop by writing a new message to the FIFO the loop will terminate, one or two flags will be transmitted and the new message will start. If not disabled via TCRCD, the transmitter will automatically append a 2-byte CRC code to the end of all messages.

Bit 5: Transmit HDLC Reset (THR). Will reset the transmit HDLC controller and flush the transmit FIFO. An abort followed by 7Eh or FFh flags/idle will be transmitted until a new packet is initiated by writing new data into the FIFO. This is an acknowledged reset, that is, the host need only to set the bit and the DS26524 will clear it once the reset operation is complete. Total time for the reset is less than 250µs.

- 0 = Normal operation
- 1 = Reset transmit HDLC controller and flush the transmit FIFO

Bit 4: Transmit HDLC Mapping Select (THMS).

- 0 = Transmit HDLC assigned to channels
- 1 = Transmit HDLC assigned to FDL (T1 mode), Sa bits (E1 mode). This mode must be enabled with [TCR2.7](#).

Bit 3: Transmit Flag/Idle Select (TFS). This bit selects the inter-message fill character after the closing and before the opening flags (7Eh).

- 0 = 7Eh
- 1 = FFh

Bit 2: Transmit End of Message (TEOM). Should be set to a one just before the last data byte of an HDLC packet is written into the transmit FIFO at THF. If not disabled via TCRCD, the transmitter will automatically append a 2-byte CRC code to the end of the message.

Bit 1: Transmit Zero Stuffer Defeat (TZSD). The zero stuffer function automatically inserts a zero in the message field (between the flags) after five consecutive ones to prevent the emulation of a flag or abort sequence by the data pattern. The receiver automatically removes (destuffs) any zero after five ones in the message field.

- 0 = enable the zero stuffer (normal operation)
- 1 = disable the zero stuffer

Bit 0: Transmit CRC Defeat (TCRCD). A 2-byte CRC code is automatically appended to the outbound message. This bit can be used to disable the CRC function.

- 0 = enable CRC generation (normal operation)
- 1 = disable CRC generation

Register Name: **THBSE**
 Register Description: **Transmit HDLC Bit Suppress Register**
 Register Address: **111h + (200h x n): where n = 0 to 3, for Ports 1 to 4**

Bit #	7	6	5	4	3	2	1	0
Name	TBSE8	TBSE7	TBSE6	TBSE5	TBSE4	TBSE3	TBSE2	TBSE1
Default	0	0	0	0	0	0	0	0

Bit 7: Transmit Bit 8 Suppress (TBSE8). MSB of the channel. Set to one to stop this bit from being used.

Bit 6: Transmit Bit 7 Suppress (TBSE7). Set to one to stop this bit from being used.

Bit 5: Transmit Bit 6 Suppress (TBSE6). Set to one to stop this bit from being used.

Bit 4: Transmit Bit 5 Suppress (TBSE5). Set to one to stop this bit from being used.

Bit 3: Transmit Bit 4 Suppress (TBSE4). Set to one to stop this bit from being used.

Bit 2: Transmit Bit 3 Suppress (TBSE3). Set to one to stop this bit from being used.

Bit 1: Transmit Bit 2 Suppress (TBSE2). Set to one to stop this bit from being used.

Bit 0: Transmit Bit 1 Suppress (TBSE1). LSB of the channel. Set to one to stop this bit from being used.

Register Name: **THC2**
 Register Description: **Transmit HDLC Control Register 2**
 Register Address: **113h + (200h x n): where n = 0 to 3, for Ports 1 to 4**

Bit #	7	6	5	4	3	2	1	0
Name	TABT	SBOC	THCEN	THCS4	THCS3	THCS2	THCS1	THCS0
	<i>TABT</i>	—	<i>THCEN</i>	<i>THCS4</i>	<i>THCS3</i>	<i>THCS2</i>	<i>THCS1</i>	<i>THCS0</i>
Default	0	0	0	0	0	0	0	0

Bit 7: Transmit Abort (TABT). A 0-to-1 transition will cause the FIFO contents to be dumped and one FEh abort to be sent followed by 7Eh or FFh flags/idle until a new packet is initiated by writing new data into the FIFO. Must be cleared and set again for a subsequent abort to be sent.

Bit 6: Send BOC (SBOC) (T1 Mode Only). Set = 1 to transmit the BOC code placed in bits 0 to 5 of the [T1TBOC](#) register.

Bit 5: Transmit HDLC Controller Enable (THCEN).

0 = Transmit HDLC controller is not enabled.

1 = Transmit HDLC controller is enabled.

Bits 4 to 0: Transmit HDLC Channel Select (THCS[4:0]). Determines which DSO channel will carry the HDLC message if enabled. Changes to this value are acknowledged only upon a transmit HDLC controller reset (THR at [THC1.5](#)).

Register Name: **E1TSACR (E1 Mode)**
 Register Description: **E1 Transmit Sa-Bit Control Register**
 Register Address: **114h + (200h x n): where n = 0 to 3, for Ports 1 to 4**

Bit #	7	6	5	4	3	2	1	0
Name	SiAF	SiNAF	RA	Sa4	Sa5	Sa6	Sa7	Sa8
Default	0	0	0	0	0	0	0	0

Bit 7: International Bit in Align Frame Insertion Control Bit (SiAF).

0 = do not insert data from the TSiAF register into the transmit data stream
 1 = insert data from the TSiAF register into the transmit data stream

Bit 6: International Bit in Non-Align Frame Insertion Control Bit (SiNAF).

0 = do not insert data from the TSiNAF register into the transmit data stream
 1 = insert data from the TSiNAF register into the transmit data stream

Bit 5: Remote Alarm Insertion Control Bit (RA).

0 = do not insert data from the TRA register into the transmit data stream
 1 = insert data from the TRA register into the transmit data stream

Bit 4: Additional Bit 4 Insertion Control Bit (Sa4).

0 = do not insert data from the TSa4 register into the transmit data stream
 1 = insert data from the TSa4 register into the transmit data stream

Bit 3: Additional Bit 5 Insertion Control Bit (Sa5).

0 = do not insert data from the TSa5 register into the transmit data stream
 1 = insert data from the TSa5 register into the transmit data stream

Bit 2: Additional Bit 6 Insertion Control Bit (Sa6).

0 = do not insert data from the TSa6 register into the transmit data stream
 1 = insert data from the TSa6 register into the transmit data stream

Bit 1: Additional Bit 7 Insertion Control Bit (Sa7).

0 = do not insert data from the TSa7 register into the transmit data stream
 1 = insert data from the TSa7 register into the transmit data stream

Bit 0: Additional Bit 8 Insertion Control Bit (Sa8).

0 = do not insert data from the TSa8 register into the transmit data stream
 1 = insert data from the TSa8 register into the transmit data stream

Register Name: **SSIE1, SSIE2, SSIE3, SSIE4**
 Register Description: **Software-Signaling Insertion Enable Registers 1 to 4**
 Register Address: **118h, 119h, 11Ah, 11Bh + (200h x n): where n = 0 to 3, for Ports 1 to 4**

Bit #	(MSB) 7	6	5	4	3	2	1	0 (LSB)	
Name	CH8	CH7	CH6	CH5	CH4	CH3	CH2	CH1	SSIE1 SSIE2 SSIE3 SSIE4 (E1 Mode Only)
	CH16	CH15	CH14	CH13	CH12	CH11	CH10	CH9	
	CH24	CH23	CH22	CH21	CH20	CH19	CH18	CH17	
	<i>CH32</i>	<i>CH31</i>	<i>CH30</i>	<i>CH29</i>	<i>CH28</i>	<i>CH27</i>	<i>CH26</i>	<i>CH25</i>	
Default	0	0	0	0	0	0	0	0	

Bits 7 to 0: Software Signaling Insertion Enable for Channels 1 to 32 (CH[1:32]). These bits determine which channels are to have signaling inserted from the transmit-signaling registers.

0 = do not source signaling data from the TS registers for this channel

1 = source signaling data from the TS registers for this channel

Register Name: **TIDR1 to TIDR32**
 Register Description: **Transmit Idle Code Definition Registers 1 to 32**
 Register Address: **120h to 13Fh + (200h x n): where n = 0 to 3, for Ports 1 to 4**

Bit #	7	6	5	4	3	2	1	0
Name	C7	C6	C5	C4	C3	C2	C1	C0
Default	0	0	0	0	0	0	0	0

Bits 7 to 0: Per-Channel Idle Code Bits (C[7:0]). C0 is the LSB of the code (this bit is transmitted last). Address 120h is for channel 1, address 13Fh is for channel 32. TIDR1:TIDR24 are T1 mode. TIDR25:TIDR32 are E1 mode.

Register Name: **TS1 to TS16**
 Register Description: **Transmit-Signaling Registers 1 to 16**
 Register Address: **140h to 14Fh + (200h x n): where n = 0 to 3, for Ports 1 to 4**

T1 Mode:

Bit #	(MSB) 7	6	5	4	3	2	1	0 (LSB)	
Name	CH1-A	CH1-B	CH1-C	CH1-D	CH13-A	CH13-B	CH13-C	CH13-D	TS1
	CH2-A	CH2-B	CH2-C	CH2-D	CH14-A	CH14-B	CH14-C	CH14-D	TS2
	CH3-A	CH3-B	CH3-C	CH3-D	CH15-A	CH15-B	CH15-C	CH15-D	TS3
	CH4-A	CH4-B	CH4-C	CH4-D	CH16-A	CH16-B	CH16-C	CH16-D	TS4
	CH5-A	CH5-B	CH5-C	CH5-D	CH17-A	CH17-B	CH17-C	CH17-D	TS5
	CH6-A	CH6-B	CH6-C	CH6-D	CH18-A	CH18-B	CH18-C	CH18-D	TS6
	CH7-A	CH7-B	CH7-C	CH7-D	CH19-A	CH19-B	CH19-C	CH19-D	TS7
	CH8-A	CH8-B	CH8-C	CH8-D	CH20-A	CH20-B	CH20-C	CH20-D	TS8
	CH9-A	CH9-B	CH9-C	CH9-D	CH21-A	CH21-B	CH21-C	CH21-D	TS9
	CH10-A	CH10-B	CH10-C	CH10-D	CH22-A	CH22-B	CH22-C	CH22-D	TS10
	CH11-A	CH11-B	CH11-C	CH11-D	CH23-A	CH23-B	CH23-C	CH23-D	TS11
	CH12-A	CH12-B	CH12-C	CH12-D	CH24-A	CH24-B	CH24-C	CH24-D	TS12

Note: In D4 framing mode, the C and D bits are not used.

E1 Mode:

Bit #	(MSB) 7	6	5	4	3	2	1	0 (LSB)	
Name	0	0	0	0	X	Y	X	X	TS1
	CH1-A	CH1-B	CH1-C	CH1-D	CH16-A	CH16-B	CH16-C	CH16-D	TS2
	CH2-A	CH2-B	CH2-C	CH2-D	CH17-A	CH17-B	CH17-C	CH17-D	TS3
	CH3-A	CH3-B	CH3-C	CH3-D	CH18-A	CH18-B	CH18-C	CH18-D	TS4
	CH4-A	CH4-B	CH4-C	CH4-D	CH19-A	CH19-B	CH19-C	CH19-D	TS5
	CH5-A	CH5-B	CH5-C	CH5-D	CH20-A	CH20-B	CH20-C	CH20-D	TS6
	CH6-A	CH6-B	CH6-C	CH6-D	CH21-A	CH21-B	CH21-C	CH21-D	TS7
	CH7-A	CH7-B	CH7-C	CH7-D	CH22-A	CH22-B	CH22-C	CH22-D	TS8
	CH8-A	CH8-B	CH8-C	CH8-D	CH23-A	CH23-B	CH23-C	CH23-D	TS9
	CH9-A	CH9-B	CH9-C	CH9-D	CH24-A	CH24-B	CH24-C	CH24-D	TS10
	CH10-A	CH10-B	CH10-C	CH10-D	CH25-A	CH25-B	CH25-C	CH25-D	TS11
	CH11-A	CH11-B	CH11-C	CH11-D	CH26-A	CH26-B	CH26-C	CH26-D	TS12
	CH12-A	CH12-B	CH12-C	CH12-D	CH27-A	CH27-B	CH27-C	CH27-D	TS13
	CH13-A	CH13-B	CH13-C	CH13-D	CH28-A	CH28-B	CH28-C	CH28-D	TS14
	CH14-A	CH14-B	CH14-C	CH14-D	CH29-A	CH29-B	CH29-C	CH29-D	TS15
	CH15-A	CH15-B	CH15-C	CH15-D	CH30-A	CH30-B	CH30-C	CH30-D	TS16

Register Name: **TCICE1, TCICE2, TCICE3, TCICE4**
 Register Description: **Transmit Channel Idle Code Enable Registers 1 to 4**
 Register Address: **150h, 151h, 152h, 153h + (200h x n): where n = 0 to 3, for Ports 1 to 4**

Bit #	(MSB) 7	6	5	4	3	2	1	0 (LSB)	
Name	CH8	CH7	CH6	CH5	CH4	CH3	CH2	CH1	TCICE1
	CH16	CH15	CH14	CH13	CH12	CH11	CH10	CH9	TCICE2
	CH24	CH23	CH22	CH21	CH20	CH19	CH18	CH17	TCICE3
	<i>CH32</i>	<i>CH31</i>	<i>CH30</i>	<i>CH29</i>	<i>CH28</i>	<i>CH27</i>	<i>CH26</i>	<i>CH25</i>	TCICE4 (E1 Mode Only)
Default	0	0	0	0	0	0	0	0	

The Transmit Channel Idle Code Enable registers (TCICE1:TCICE4) are used to determine which of the 24 T1 channels (or 32 E1 channels) from the backplane should be overwritten with the code placed in the Transmit Idle Code Definition register ([TIDR1](#):TIDR32).

Bits 7 to 0: Transmit Channels 1 to 32 Code Insertion Control Bits (CH[1:32]).

0 = do not insert data from the Idle Code Array into the transmit data stream

1 = insert data from the Idle Code Array into the transmit data stream

Register Name: **TFRID**
 Register Description: **Transmit Firmware Revision ID Register**
 Register Address: **161h + (200h x n): where n = 0 to 3, for Ports 1 to 4**

Bit #	7	6	5	4	3	2	1	0
Name	FR7	FR6	FR5	FR4	FR3	FR2	FR1	FR0
Default	0	0	0	0	0	0	0	0

Bits 7 to 0: Firmware Revision (FR[7:0]). This read-only register reports the transmitter firmware revision.

Register Name: **T1TFDL (T1 Mode)**
 Register Description: **Transmit FDL Register**
 Register Address: **162h + (200h x n): where n = 0 to 3, for Ports 1 to 4**

Bit #	7	6	5	4	3	2	1	0
Name	TFDL7	TFDL6	TFDL5	TFDL4	TFDL3	TFDL2	TFDL1	TFDL0
Default	0	0	0	0	0	0	0	0

Note: Also used to insert Fs framing pattern in D4 framing mode.

The Transmit FDL register (T1TFDL) contains the Facility Data Link (FDL) information that is to be inserted on a byte basis into the outgoing T1 data stream. The LSB is transmitted first. In D4 mode, only the lower six bits are used.

Bit 7: Transmit FDL Bit 7 (TFDL7). MSB of the transmit FDL code.

Bit 6: Transmit FDL Bit 6 (TFDL6).

Bit 5: Transmit FDL Bit 5 (TFDL5).

Bit 4: Transmit FDL Bit 4 (TFDL4).

Bit 3: Transmit FDL Bit 3 (TFDL3).

Bit 2: Transmit FDL Bit 2 (TFDL2).

Bit 1: Transmit FDL Bit 1 (TFDL1).

Bit 0: Transmit FDL Bit 0 (TFDL0). LSB of the transmit FDL code.

Register Name: **T1TBOC (T1 Mode Only)**
 Register Description: **Transmit BOC Register**
 Register Address: **163h + (200h x n): where n = 0 to 3, for Ports 1 to 4**

Bit #	7	6	5	4	3	2	1	0
Name	—	—	TBOC5	TBOC4	TBOC3	TBOC2	TBOC1	TBOC0
Default	0	0	0	0	0	0	0	0

Bit 5: Transmit BOC Bit 5 (TBOC5). MSB of the transmit BOC code.

Bit 4: Transmit BOC Bit 4 (TBOC4).

Bit 3: Transmit BOC Bit 3 (TBOC3).

Bit 2: Transmit BOC Bit 2 (TBOC2).

Bit 1: Transmit BOC Bit 1 (TBOC1).

Bit 0: Transmit BOC Bit 0 (TBOC0). LSB of the transmit BOC code.

Register Name: **T1TSLC1, T1TSLC2, T1TSLC3 (T1 Mode)**
 Register Description: **Transmit SLC-96 Data Link Registers 1 to 3**
 Register Address: **164h, 165h, 166h + (200h x n): where n = 0 to 3, for Ports 1 to 4**

Bit #	(MSB) 7	6	5	4	3	2	1	0 (LSB)	
Name	C8	C7	C6	C5	C4	C3	C2	C1	T1TSLC1
	M2	M1	S=0	S=1	S=0	C11	C10	C9	T1TSLC2
	S=1	S4	S3	S2	S1	A2	A1	M3	T1TSLC3
Default	0	0	0	0	0	0	0	0	

Note: See [E1TAF](#), [E1TNAF](#), and [E1TSlAF](#) for E1 modes.

Register Name: **E1TAF (E1 Mode)**
 Register Description: **Transmit Align Frame Register**
 Register Address: **164h + (200h x n): where n = 0 to 3, for Ports 1 to 4**

Bit #	7	6	5	4	3	2	1	0
Name	Si	0	0	1	1	0	1	1
Default	0	0	0	1	1	0	1	1

Bit 7: International Bit (Si).

Bit 6: Frame Alignment Signal Bit (0).

Bit 5: Frame Alignment Signal Bit (0).

Bit 4: Frame Alignment Signal Bit (1).

Bit 3: Frame Alignment Signal Bit (1).

Bit 2: Frame Alignment Signal Bit (0).

Bit 1: Frame Alignment Signal Bit (1).

Bit 0: Frame Alignment Signal Bit (1).

Register Name: **E1TNAF (E1 Mode)**
 Register Description: **Transmit Non-Align Frame Register**
 Register Address: **165h + (200h x n): where n = 0 to 3, for Ports 1 to 4**

Bit #	7	6	5	4	3	2	1	0
Name	Si	1	A	Sa4	Sa5	Sa6	Sa7	Sa8
Default	0	1	0	0	0	0	0	0

Bit 7: International Bit (Si).

Bit 6: Frame Non-Alignment Signal Bit (1).

Bit 5: Remote Alarm (Used to Transmit the Alarm) (A).

Bit 4: Additional Bit 4 (Sa4).

Bit 3: Additional Bit 5 (Sa5).

Bit 2: Additional Bit 6 (Sa6).

Bit 1: Additional Bit 7 (Sa7).

Bit 0: Additional Bit 8 (Sa8).

Register Name: **E1TSiAF (E1 Mode)**
 Register Description: **Transmit Si Bits of the Align Frame Register**
 Register Address: **166h + (200h x n): where n = 0 to 3, for Ports 1 to 4**

Bit #	7	6	5	4	3	2	1	0
Name	TSiF14	TSiF12	TSiF10	TSiF8	TSiF6	TSiF4	TSiF2	TSiF0
Default	0	0	0	0	0	0	0	0

Bit 7: Si Bit of Frame 14 (TSiF14).

Bit 6: Si Bit of Frame 12 (TSiF12).

Bit 5: Si Bit of Frame 10 (TSiF10).

Bit 4: Si Bit of Frame 8 (TSiF8).

Bit 3: Si Bit of Frame 6 (TSiF6).

Bit 2: Si Bit of Frame 4 (TSiF4).

Bit 1: Si Bit of Frame 2 (TSiF2).

Bit 0: Si Bit of Frame 0 (TSiF0).

Register Name: **E1TSiNAF (E1 Mode Only)**
 Register Description: **Transmit Si Bits of the Non-Align Frame Register**
 Register Address: **167h + (200h x n): where n = 0 to 3, for Ports 1 to 4**

Bit #	7	6	5	4	3	2	1	0
Name	TSiF15	TSiF13	TSiF11	TSiF9	TSiF7	TSiF5	TSiF3	TSiF1
Default	0	0	0	0	0	0	0	0

Bit 7: Si Bit of Frame 15 (TSiF15).

Bit 6: Si Bit of Frame 13 (TSiF13).

Bit 5: Si Bit of Frame 11 (TSiF11).

Bit 4: Si Bit of Frame 9 (TSiF9).

Bit 3: Si Bit of Frame 7 (TSiF7).

Bit 2: Si Bit of Frame 5 (TSiF5).

Bit 1: Si Bit of Frame 3 (TSiF3).

Bit 0: Si Bit of Frame 1 (TSiF1).

Register Name: **E1TRA (E1 Mode Only)**
 Register Description: **Transmit Remote Alarm Register**
 Register Address: **168h + (200h x n): where n = 0 to 3, for Ports 1 to 4**

Bit #	7	6	5	4	3	2	1	0
Name	TRAF15	TRAF13	TRAF11	TRAF9	TRAF7	TRAF5	TRAF3	TRAF1
Default	0	0	0	0	0	0	0	0

Bit 7: Remote Alarm Bit of Frame 15 (TRAF15).

Bit 6: Remote Alarm Bit of Frame 13 (TRAF13).

Bit 5: Remote Alarm Bit of Frame 11 (TRAF11).

Bit 4: Remote Alarm Bit of Frame 9 (TRAF9).

Bit 3: Remote Alarm Bit of Frame 7 (TRAF7).

Bit 2: Remote Alarm Bit of Frame 5 (TRAF5).

Bit 1: Remote Alarm Bit of Frame 3 (TRAF3).

Bit 0: Remote Alarm Bit of Frame 1 (TRAF1).

Register Name: **E1TSa4 (E1 Mode Only)**
 Register Description: **Transmit Sa4 Bits Register**
 Register Address: **169h + (200h x n): where n = 0 to 3, for Ports 1 to 4**

Bit #	7	6	5	4	3	2	1	0
Name	TSa4F15	TSa4F13	TSa4F11	TSa4F9	TSa4F7	TSa4F5	TSa4F3	TSa4F1
Default	0	0	0	0	0	0	0	0

Bit 7: Sa4 Bit of Frame 15 (TSa4F15).

Bit 6: Sa4 Bit of Frame 13 (TSa4F13).

Bit 5: Sa4 Bit of Frame 11 (TSa4F11).

Bit 4: Sa4 Bit of Frame 9 (TSa4F9).

Bit 3: Sa4 Bit of Frame 7 (TSa4F7).

Bit 2: Sa4 Bit of Frame 5 (TSa4F5).

Bit 1: Sa4 Bit of Frame 3 (TSa4F3).

Bit 0: Sa4 Bit of Frame 1 (TSa4F1).

Register Name: **E1TSa5 (E1 Mode Only)**
 Register Description: **Transmit Sa5 Bits Register**
 Register Address: **16Ah + (200h x n): where n = 0 to 3, for Ports 1 to 4**

Bit #	7	6	5	4	3	2	1	0
Name	TSa5F15	TSa5F13	TSa5F11	TSa5F9	TSa5F7	TSa5F5	TSa5F3	TSa5F1
Default	0	0	0	0	0	0	0	0

Bit 7: Sa5 Bit of Frame 15 (TSa5F15).

Bit 6: Sa5 Bit of Frame 13 (TSa5F13).

Bit 5: Sa5 Bit of Frame 11 (TSa5F11).

Bit 4: Sa5 Bit of Frame 9 (TSa5F9).

Bit 3: Sa5 Bit of Frame 7 (TSa5F7).

Bit 2: Sa5 Bit of Frame 5 (TSa5F5).

Bit 1: Sa5 Bit of Frame 3 (TSa5F3).

Bit 0: Sa5 Bit of Frame 1 (TSa5F1).

Register Name: **E1TSa6 (E1 Mode)**
 Register Description: **Transmit Sa6 Bits Register**
 Register Address: **16Bh + (200h x n): where n = 0 to 3, for Ports 1 to 4**

Bit #	7	6	5	4	3	2	1	0
Name	TSa6F15	TSa6F13	TSa6F11	TSa6F9	TSa6F7	TSa6F5	TSa6F3	TSa6F1
Default	0	0	0	0	0	0	0	0

Bit 7: Sa6 Bit of Frame 15 (TSa6F15).

Bit 6: Sa6 Bit of Frame 13 (TSa6F13).

Bit 5: Sa6 Bit of Frame 11 (TSa6F11).

Bit 4: Sa6 Bit of Frame 9 (TSa6F9).

Bit 3: Sa6 Bit of Frame 7 (TSa6F7).

Bit 2: Sa6 Bit of Frame 5 (TSa6F5).

Bit 1: Sa6 Bit of Frame 3 (TSa6F3).

Bit 0: Sa6 Bit of Frame 1 (TSa6F1).

Register Name: **E1TSa7 (E1 Mode Only)**
 Register Description: **Transmit Sa7 Bits Register**
 Register Address: **16Ch + (200h x n): where n = 0 to 3, for Ports 1 to 4**

Bit #	7	6	5	4	3	2	1	0
Name	TSa7F15	TSa7F13	TSa7F11	TSa7F9	TSa7F7	TSa7F5	TSa7F3	TSa7F1
Default	0	0	0	0	0	0	0	0

Bit 7: Sa7 Bit of Frame 15 (TSa7F15).

Bit 6: Sa7 Bit of Frame 13 (TSa7F13).

Bit 5: Sa7 Bit of Frame 11 (TSa7F11).

Bit 4: Sa7 Bit of Frame 9 (TSa7F9).

Bit 3: Sa7 Bit of Frame 7 (TSa7F7).

Bit 2: Sa7 Bit of Frame 5 (TSa7F5).

Bit 1: Sa7 Bit of Frame 3 (TSa7F3).

Bit 0: Sa7 Bit of Frame 1 (TSa7F1).

Register Name: **E1TSa8 (E1 Mode Only)**
 Register Description: **Transmit Sa8 Bits Register**
 Register Address: **16Dh + (200h x n): where n = 0 to 3, for Ports 1 to 4**

Bit #	7	6	5	4	3	2	1	0
Name	TSa8F15	TSa8F13	TSa8F11	TSa8F9	TSa8F7	TSa8F5	TSa8F3	TSa8F1
Default	0	0	0	0	0	0	0	0

Bit 7: Sa8 Bit of Frame 15 (TSa8F15).

Bit 6: Sa8 Bit of Frame 13 (TSa8F13).

Bit 5: Sa8 Bit of Frame 11 (TSa8F11).

Bit 4: Sa8 Bit of Frame 9 (TSa8F9).

Bit 3: Sa8 Bit of Frame 7 (TSa8F7).

Bit 2: Sa8 Bit of Frame 5 (TSa8F5).

Bit 1: Sa8 Bit of Frame 3 (TSa8F3).

Bit 0: Sa8 Bit of Frame 1 (TSa8F1).

Register Name: **TMMR**
 Register Description: **Transmit Master Mode Register**
 Register Address: **180h + (200h x n): where n = 0 to 3, for Ports 1 to 4**

Bit #	7	6	5	4	3	2	1	0
Name	FRM_EN	INIT_DONE	—	—	—	—	SFTRST	T1/E1
Default	0	0	0	0	0	0	0	0

Bit 7: Framer Enable (FRM_EN). This bit must be set to the desired state before writing INIT_DONE.
 0 = Framer disabled—held in low-power state
 1 = Framer enabled—all features active

Bit 6: Initialization Done (INIT_DONE). The user must set this bit once he has written the configuration registers. The host is required to write or clear all device registers prior to setting this bit. Once INIT_DONE is set, the DS26524 will check the FRM_EN bit and, if enabled will begin operation based on the initial configuration.

Bit 1: Soft Reset (SFTRST). Level sensitive-soft reset. Should be taken high then low to reset the transceiver.
 0 = Normal operation
 1 = Reset the transceiver

Bit 0: Transmitter T1/E1 Mode Select (T1/E1). Sets operating mode for transmitter only! This bit must be written with the desired value prior to setting INIT_DONE.
 0 = T1 operation
 1 = E1 operation

Register Name: **TCR1 (T1 Mode)**
 Register Description: **Transmit Control Register 1**
 Register Address: **181h + (200h x n): where n = 0 to 3, for Ports 1 to 4**

Bit #	7	6	5	4	3	2	1	0
Name	TJC	TFPT	TCPT	TSSE	GB7S	TB8ZS	TAIS	TRAI
Default	0	0	0	0	0	0	0	0

Note: See [TCR1](#) for E1 mode.

Bit 7: Transmit Japanese CRC-6 Enable (TJC).

- 0 = use ANSI/AT&T:ITU-T CRC-6 calculation (normal operation)
- 1 = use Japanese standard JT-G704 CRC-6 calculation

Bit 6: Transmit F-Bit Pass Through (TFPT).

- 0 = F-bits sourced internally
- 1 = F-bits sampled at TSER

Bit 5: Transmit CRC Pass Through (TCPT).

- 0 = source CRC-6 bits internally
- 1 = CRC-6 bits sampled at TSER during F-bit time

Bit 4: Transmit Software-Signaling Enable (TSSE). This function is enabled by TB7ZS ([TCR2.0](#)).

- 0 = do not source signaling data from the TSx registers regardless of the SSIEx registers. The SSIEx registers still define which channels are to have B7 stuffing performed.
- 1 = source signaling data as enabled by the SSIEx registers.

Bit 3: Global Bit 7 Stuffing (GB7S). This function is enabled by TB7ZS ([TCR2.0](#)).

- 0 = allow the SSIEx registers to determine which channels containing all zeros are to be bit 7 stuffed
- 1 = force bit 7 stuffing in all zero-byte channels of that port, regardless of how the SSIEx registers are programmed

Bit 2: Transmit B8ZS Enable (TB8ZS).

- 0 = B8ZS disabled
- 1 = B8ZS enabled

Bit 1: Transmit Alarm Indication Signal (TAIS).

- 0 = transmit data normally
- 1 = transmit an unframed all-ones code at TPOS and TNEG

Bit 0: Transmit Remote Alarm Indication (TRAI).

- 0 = do not transmit remote alarm
- 1 = transmit remote alarm

Register Name: **TCR1 (E1 Mode)**
 Register Description: **Transmit Control Register 1**
 Register Address: **181h + (200h x n): where n = 0 to 3, for Ports 1 to 4**

Bit #	7	6	5	4	3	2	1	0
Name	TTPT	T16S	TG802	TSiS	TSA1	THDB3	TAIS	TCRC4
Default	0	0	0	0	0	0	0	0

Note: See [TCR1](#) for T1 mode.

Bit 7: Transmit Time Slot 0 Pass Through (TTPT).

0 = FAS bits/Sa bits/remote alarm sourced internally from the [E1TAF](#) and [E1TNAF](#) registers
 1 = FAS bits/Sa bits/remote alarm sourced from TSER

Bit 6: Transmit Time Slot 16 Data Select (T16S). See Section [8.9.4](#) on software signaling.

0 = time slot 16 determined by the SSIEx and [THSCS1:THSCS4](#) registers
 1 = source time slot 16 from [TS1](#):TS16 registers

Bit 5: Transmit G.802 Enable (TG802). See Section [10.4](#).

0 = do not force TCHBLK high during bit 1 of time slot 26
 1 = force TCHBLK high during bit 1 of time slot 26

Bit 4: Transmit International Bit Select (TSiS).

0 = sample Si bits at TSER pin
 1 = source Si bits from [E1TAF](#) and [E1TNAF](#) registers (in this mode, TCR1.7 must be set to 0)

Bit 3: Transmit-Signaling All Ones (TSA1).

0 = normal operation
 1 = force time slot 16 in every frame to all ones

Bit 2: Transmit HDB3 Enable (THDB3).

0 = HDB3 disabled
 1 = HDB3 enabled

Bit 1: Transmit AIS (TAIS).

0 = transmit data normally
 1 = transmit an unframed all-ones code at TPOS and TNEG

Bit 0: Transmit CRC-4 Enable (TCRC4).

0 = CRC-4 disabled
 1 = CRC-4 enabled

Register Name: **TCR2 (T1 Mode)**
 Register Description: **Transmit Control Register 2**
 Register Address: **182h + (200h x n): where n = 0 to 3, for Ports 1 to 4**

Bit #	7	6	5	4	3	2	1	0
Name	TFDLS	TSLC96	—	FBCT2	FBCT1	TD4RM	PDE	TB7ZS
Default	0	0	0	0	0	0	0	0

Note: See [TCR2](#) for E1 mode.

Bit 7: TFDL Register Select (TFDLS).

- 0 = source FDL or Fs bits from the internal TFDL register or the SLC-96 data formatter (TCR2.6)
- 1 = source FDL or Fs bits from the internal HDLC controller

Bit 6: Transmit SLC-96 (TSLC96). Set this bit to a one in SLC-96 framing applications. Must be set to source the SLC-96 alignment pattern and data from the [T1TSLC1:T1TSLC3](#) registers. See Section [8.9.4.4](#) for details.

- 0 = SLC-96 insertion disabled
- 1 = SLC-96 insertion enabled

Bit 4: F-Bit Corruption Type 2 (FBCT2). Setting this bit high enables the corruption of one Ft (D4 framing mode) or FPS (ESF framing mode) bit in every 128 Ft or FPS bits as long as the bit remains set.

Bit 3: F-Bit Corruption Type 1 (FBCT1). A low-to-high transition of this bit causes the next three consecutive Ft (D4 framing mode) or FPS (ESF framing mode) bits to be corrupted causing the remote end to experience a loss of synchronization.

Bit 2: Transmit D4 RAI Select (TD4RM).

- 0 = zeros in bit 2 of all channels
- 1 = a one in the S-bit position of frame 12

Bit 1: Pulse Density Enforcer Enable (PDE). The framer always examines both the transmit and receive data streams for violations of the following rules which are required by ANSI T1.403: no more than 15 consecutive zeros and at least N ones in each and every time window of $8 \times (N + 1)$ bits where $N = 1$ through 23. Violations for the transmit and receive data streams are reported in the [TLS1.3](#) and [RLS2.7](#) bits, respectively. When this bit is set to one, the DS26524 will force the transmitted stream to meet this requirement no matter the content of the transmitted stream. When running B8ZS, this bit should be set to zero since B8ZS-encoded data streams cannot violate the pulse density requirements.

- 0 = disable transmit pulse density enforcer
- 1 = enable transmit pulse density enforcer

Bit 0: Transmit-Side Bit 7 Zero-Suppression Enable (TB7ZS).

- 0 = no stuffing occurs
- 1 = force bit 7 to a one as determined by the GB7S bit at [TCR1.3](#)

Register Name: **TCR2 (E1 Mode)**
 Register Description: **Transmit Control Register 2**
 Register Address: **182h + (200h x n): where n = 0 to 3, for Ports 1 to 4**

Bit #	7	6	5	4	3	2	1	0
Name	AEBE	AAIS	ARA	Sa4S	Sa5S	Sa6S	Sa7S	Sa8S
Default	0	0	0	0	0	0	0	0

Note: See [TCR2](#) for T1 mode.

Bit 7: Automatic E-Bit Enable (AEBE).

- 0 = E-bits not automatically set in the transmit direction
- 1 = E-bits automatically set in the transmit direction

Bit 6: Automatic AIS Generation (AAIS).

- 0 = disabled
- 1 = enabled

Bit 5: Automatic Remote Alarm Generation (ARA).

- 0 = disabled
- 1 = enabled

Bit 4: Sa4 Bit Select (Sa4S). Set to one to source the Sa4 bit; set to zero to not source the Sa4 bit.

Bit 3: Sa5 Bit Select (Sa5S). Set to one to source the Sa5 bit; set to zero to not source the Sa5 bit.

Bit 2: Sa6 Bit Select (Sa6S). Set to one to source the Sa6 bit; set to zero to not source the Sa6 bit

Bit 1: Sa7 Bit Select (Sa7S). Set to one to source the Sa7 bit; set to zero to not source the Sa7 bit.

Bit 0: Sa8 Bit Select (Sa8S). Set to one to source the Sa8 bit; set to zero to not source the Sa8 bit.

Register Name: **TCR3**
 Register Description: **Transmit Control Register 3**
 Register Address: **183h + (200h x n): where n = 0 to 3, for Ports 1 to 4**

Bit #	7	6	5	4	3	2	1	0
Name	ODF	ODM	TCSS1	TCSS0	MFRS	TFM	IBPV	TLOOP
	<i>ODF</i>	<i>ODM</i>	<i>TCSS1</i>	<i>TCSS0</i>	<i>MFRS</i>	—	<i>IBPV</i>	<i>CRC4R</i>
Default	0	0	0	0	0	0	0	0

Bit 7: Output Data Format (ODF).

0 = bipolar data at TTIP and TRING
 1 = NRZ data at TTIP; TRING = 0

Bit 6: Output Data Mode (ODM).

0 = pulses at TTIP and TRING are one full TCLK period wide
 1 = pulses at TTIP and TRING are 1/2 TCLK period wide

Bits 5 and 4: Transmit Clock Source Select 1 and 0 (TCSS[1:0]).

TCSS1	TCSS0	TRANSMIT CLOCK SOURCE
0	0	The TCLK pin is always the source of transmit clock.
0	1	Switch to the clock present at RCLK when the signal at the TCLK pin fails to transition after one channel time.
1	0	Reserved
1	1	Use the signal present at RCLK as the transmit clock. The TCLK pin is ignored.

Bit 3: Multiframe Reference Select (MFRS). This bit selects the source for the transmit formatter multiframe boundary.

0 = Normal operation. Transmit multiframe boundary is determined by line-side counters referenced to TSYNC when TSYNC is an input. Free-running when TSYNC is an output.

1 = Pass-forward operation. Transmit multiframe boundary determined by system-side counters referenced to TSSYNCIO (input mode 3), which is then passed forward to the line-side clock domain. This mode can only be used when the transmit elastic store is enabled with a synchronous backplane (i.e., no frame slips allowed). This mode must be used to allow transmit hardware-signaling insertion while the transmit elastic store is enabled.

Bit 2: Transmit Frame Mode Select (TFM) (T1 Mode Only).

0 = ESF framing mode
 1 = D4 framing mode

Bit 1: Insert BPV (IBPV). A 0-to-1 transition on this bit will cause a single bipolar violation (BPV) to be inserted into the transmit data stream. Once this bit has been toggled from 0 to 1, the device waits for the next occurrence of three consecutive ones to insert the BPV. This bit must be cleared and set again for a subsequent error to be inserted.

Bit 0 (T1 Mode): Transmit Loop Code Enable (TLOOP). See Section [8.9.15](#) for details.

0 = transmit data normally
 1 = replace normal transmitted data with repeating code as defined in registers [T1TCD1](#) and [T1TCD2](#)

Bit 0 (E1 Mode): CRC-4 Recalculate (CRC4R).

0 = transmit CRC-4 generation and insertion operates in normal mode
 1 = transmit CRC-4 generation operates according to G.706 Intermediate Path Recalculation method

Register Name: **TIOCR**
 Register Description: **Transmit I/O Configuration Register**
 Register Address: **184h + (200h x n): where n = 0 to 3, for Ports 1 to 4**

Bit #	7	6	5	4	3	2	1	0
Name	TCLKINV	TSYNCINV	TSSYNCINV	TSCLKM	TSSM	TSIO	TSDW	TSM
Default	0	0	0	0	0	0	—	TSM

Bit 7: TCLK Invert (TCLKINV).

0 = No inversion
 1 = Invert

Bit 6: TSYNC Invert (TSYNCINV).

0 = No inversion
 1 = Invert

Bit 5: TSSYNCIO Invert (TSSYNCINV) (Input Mode Only).

0 = No inversion
 1 = Invert

Bit 4: TSYCLK Mode Select (TSCLKM).

0 = if TSYCLK is 1.544MHz
 1 = if TSYCLK is 2.048/4.096/8.192MHz or IBO enabled (see Section [8.8.2](#) for details on IBO function)

Bit 3: TSSYNCIO Mode Select (TSSM). Selects frame or multiframe mode for the TSSYNCIO pin.

0 = frame mode
 1 = multiframe mode

Bit 2: TSYNC I/O Select (TSIO).

0 = TSYNC is an input
 1 = TSYNC is an output

Bit 1: TSYNC Double-Wide (TSDW) (T1 Mode Only). (Note: This bit must be set to zero when TSM = 1 or when TSIO = 0.)

0 = do not pulse double-wide in signaling frames
 1 = do pulse double-wide in signaling frames

Bit 0: TSYNC Mode Select (TSM). Selects frame or multiframe mode for the TSYNC pin.

0 = frame mode
 1 = multiframe mode

Register Name: **TESCR**
 Register Description: **Transmit Elastic Store Control Register**
 Register Address: **185h + (200h x n): where n = 0 to 3, for Ports 1 to 4**

Bit #	7	6	5	4	3	2	1	0
Name	TDATFMT	TGCLKEN	—	TSZS	TESALGN	TESR	TESMDM	TESE
Default	0	0	0	0	0	0	0	0

Note: Bits 7 and 6 are used for fractional backplane support. See Section [8.8.5](#).

Bit 7: Transmit Channel Data Format (TDATFMT).

- 0 = 64kbps (data contained in all 8 bits)
- 1 = 56kbps (data contained in 7 out of the 8 bits)

Bit 6: Transmit Gapped-Clock Enable (TGCLKEN).

- 0 = TCHCLK functions normally
- 1 = enable gapped bit clock output on TCHCLK

Bit 4: Transmit Slip Zone Select (TSZS). This bit determines the minimum distance allowed between the elastic store read and write pointers before forcing a controlled slip. This bit is only applies during T1-to-E1 or E1-to-T1 conversion applications.

- 0 = force a slip at 9 bytes or less of separation (used for clustered blank channels)
- 1 = force a slip at 2 bytes or less of separation (used for distributed blank channels)

Bit 3: Transmit Elastic Store Align (TESALGN). Setting this bit from 0 to 1 will force the transmit elastic store's write/read pointers to a minimum separation of half a frame. No action will be taken if the pointer separation is already greater or equal to half a frame. If pointer separation is less than half a frame, the command will be executed and the data will be disrupted. Should be toggled after TSYCLK has been applied and is stable. Must be cleared and set again for a subsequent align.

Bit 2: Transmit Elastic Store Reset (TESR). Setting this bit from 0 to 1 will force the read pointer into the same frame that the write pointer is exiting, minimizing the delay through the elastic store. If this command should place the pointers within the slip zone (see bit 4), then an immediate slip will occur and the pointers will move back to opposite frames. Should be toggled after TSYCLK has been applied and is stable. Do not leave this bit set HIGH.

Bit 1: Transmit Elastic Store Minimum-Delay Mode (TESMDM).

- 0 = elastic stores operate at full two-frame depth
- 1 = elastic stores operate at 32-bit depth

Bit 0: Transmit Elastic Store Enable (TESE).

- 0 = elastic store is bypassed
- 1 = elastic store is enabled

Register Name: **TCR4 (T1 Mode Only)**
 Register Description: **Transmit Control Register 4**
 Register Address: **186h + (200h x n): where n = 0 to 3, for Ports 1 to 4**

Bit #	7	6	5	4	3	2	1	0
Name	—	—	—	—	TRAIM	TAISM	TC1	TC0
Default	0	0	0	0	0	0	0	0

Bits 3: Transmit RAI Mode (TRAIM). Determines the pattern sent when TRAI ([TCR1.0](#)) is activated in ESF frame mode only.

- 0 = transmit normal RAI upon activation with [TCR1.0](#)
- 1 = transmit RAI-CI (T1.403) upon activation with [TCR1.0](#)

Bits 2: Transmit AIS Mode (TAISM). Determines the pattern sent when TAIS ([TCR1.1](#)) is activated.

- 0 = transmit normal AIS (unframed all ones) upon activation with [TCR1.1](#)
- 1 = transmit AIS-CI (T1.403) upon activation with [TCR1.1](#)

Bits 1 and 0: Transmit Code Length Definition Bits (TC[1:0]).

TC1	TC0	LENGTH SELECTED (BITS)
0	0	5
0	1	6 : 3
1	0	7
1	1	16 : 8 : 4 : 2 : 1

Register Name: **THFC**
 Register Description: **Transmit HDLC FIFO Control Register**
 Register Address: **187h + (200h x n): where n = 0 to 3, for Ports 1 to 4**

Bit #	7	6	5	4	3	2	1	0
Name	—	—	—	—	—	—	TFLWM1	TFLWM2
Default	0	0	0	0	0	0	0	0

Bits 1 and 0: Transmit HDLC FIFO Low Watermark Select (TFLWM[1:2]).

TFLWM1	TFLWM2	TRANSMIT FIFO WATERMARK (BYTES)
0	0	4
0	1	16
1	0	32
1	1	48

Register Name: **TIBOC**
 Register Description: **Transmit Interleave Bus Operation Control Register**
 Register Address: **188h + (200h x n): where n = 0 to 3, for Ports 1 to 4**

Bit #	7	6	5	4	3	2	1	0
Name	—	IBS1	IBS0	IBOSEL	IBOEN	DA2	DA1	DA0
Default	0	0	0	0	0	0	0	0

Bits 6 and 5: IBO Bus Size (IBS[1:0]). Indicates how many devices are on the bus.

IBS1	IBS0	BUS SIZE
0	0	2 devices on bus
0	1	4 devices on bus
1	0	8 devices on bus
1	1	Reserved for future use

Bit 4: Interleave Bus Operation Select (IBOSEL). This bit selects channel or frame interleave mode.
 0 = Channel Interleave
 1 = Frame Interleave

Bit 3: Interleave Bus Operation Enable (IBOEN).
 0 = Interleave Bus Operation disabled
 1 = Interleave Bus Operation enabled

Bits 2 to 0: Device Assignment Bits (DA[2:0]).

DA2	DA1	DA0	DEVICE POSITION
0	0	0	1st device on bus
0	0	1	2nd device on bus
0	1	0	3rd device on bus
0	1	1	4th device on bus
1	0	0	5th device on bus
1	0	1	6th device on bus
1	1	0	7th device on bus
1	1	1	8th device on bus

Register Name: **TDS0SEL**
 Register Description: **Transmit DS0 Channel Monitor Select Register**
 Register Address: **189h + (200h x n): where n = 0 to 3, for Ports 1 to 4**

Bit #	7	6	5	4	3	2	1	0
Name	—	—	—	TCM4	TCM3	TCM2	TCM1	TCM0
Default	0	0	0	0	0	0	0	0

Bits 4 to 0: Transmit Channel Monitor Bits (TCM[4:0]). TCM0 is the LSB of a 5-bit channel select that determines which transmit channel data will appear in the [TDS0M](#) register. Channels 1 to 32 are represented by a 5-bit BCD code from 0 to 31. TCM[4:0] = all zeros selects channel 1, TCM[4:0] = 11111 selects channel 32.

Register Name: **TXPC**
 Register Description: **Transmit Expansion Port Control Register**
 Register Address: **18Ah + (200h x n): where n = 0 to 3, for Ports 1 to 4**

Bit #	7	6	5	4	3	2	1	0
Name	—	—	—	—	—	TBPDIR	TBPFUS	TBPEN
Default	0	0	0	0	0	0	0	0

Bit 2: Transmit BERT Port Direction Control (TBPDIR).

0 = Normal (line) operation. Transmit BERT port sources data into the transmit path.

1 = System (backplane) operation. Transmit BERT port sources data into the receive path (RDATA). In this mode the data out of the transmit BERT is muxed into the receive path at RDATA (the line side of the elastic store).

Bit 1: Transmit BERT Port Framed/Unframed Select (TBPFUS).

0 = The transmit BERT will *not* clock data into the F-bit position (framed)

1 = The transmit BERT will clock data into the F-bit position (unframed)

Bit 0: Transmit BERT Port Enable (TBPEN).

0 = Transmit BERT port is not active

1 = Transmit BERT port is active

Register Name: **TBPBS**
 Register Description: **Transmit BERT Port Bit Suppress Register**
 Register Address: **18Bh + (200h x n): where n = 0 to 3, for Ports 1 to 4**

Bit #	7	6	5	4	3	2	1	0
Name	BPBSE8	BPBSE7	BPBSE6	BPBSE5	BPBSE4	BPBSE3	BPBSE2	BPBSE1
Default	0	0	0	0	0	0	0	0

Bit 7: Transmit Channel Bit 8 Suppress (BPBSE8). MSB of the channel. Set to one to stop this bit from being used.

Bit 6: Transmit Channel Bit 7 Suppress (BPBSE7). Set to one to stop this bit from being used.

Bit 5: Transmit Channel Bit 6 Suppress (BPBSE6). Set to one to stop this bit from being used.

Bit 4: Transmit Channel Bit 5 Suppress (BPBSE5). Set to one to stop this bit from being used.

Bit 3: Transmit Channel Bit 4 Suppress (BPBSE4). Set to one to stop this bit from being used.

Bit 2: Transmit Channel Bit 3 Suppress (BPBSE3). Set to one to stop this bit from being used.

Bit 1: Transmit Channel Bit 2 Suppress (BPBSE2). Set to one to stop this bit from being used.

Bit 0: Transmit Channel Bit 1 Suppress (BPBSE1). LSB of the channel. Set to one to stop this bit from being used.

Register Name: **TSYNCC**
 Register Description: **Transmit Synchronizer Control Register**
 Register Address: **18Eh + (200h x n): where n = 0 to 3, for Ports 1 to 4**

Bit #	7	6	5	4	3	2	1	0
Name	—	—	—	—	—	TSEN	SYNCE	RESYNC
	—	—	—	—	CRC4	TSEN	SYNCE	RESYNC
Default	0	0	0	0	0	0	0	0

Bit 3: CRC-4 Enable (CRC4) (E1 Mode Only).

0 = Do not search for the CRC-4 multiframe word

1 = Search for the CRC-4 multiframe word

Bit 2: Transmit Synchronizer Enable (TSEN).

0 = Transmit synchronizer disabled

1 = Transmit synchronizer enabled

Bit 1: Sync Enable (SYNCE).

0 = auto resync enabled

1 = auto resync disabled

Bit 0: Resynchronize (RESYNC). When toggled from low to high, a resynchronization of the transmit-side framer is initiated. Must be cleared and set again for a subsequent resync.

Register Name: **TLS1**
 Register Description: **Transmit Latched Status Register 1**
 Register Address: **190h + (200h x n): where n = 0 to 3, for Ports 1 to 4**

Bit #	7	6	5	4	3	2	1	0
Name	TESF	TESEM	TSLIP	TSLC96	TPDV	TMF	LOTCC	LOTCC
	<i>TESF</i>	<i>TESEM</i>	<i>TSLIP</i>	—	<i>TAF</i>	<i>TMF</i>	<i>LOTCC</i>	<i>LOTCC</i>
Default	0	0	0	0	0	0	0	0

Note: All bits in this register are latched and can cause interrupts.

Bit 7: Transmit Elastic Store Full Event (TESF). Set when the transmit elastic store buffer fills and a frame is deleted.

Bit 6: Transmit Elastic Store Empty Event (TESEM). Set when the transmit elastic store buffer empties and a frame is repeated.

Bit 5: Transmit Elastic Store Slip Occurrence Event (TSLIP). Set when the transmit elastic store has either repeated or deleted a frame.

Bit 4: Transmit SLC-96 Multiframe Event (TSLC96) (T1 Mode Only). When enabled by [TCR2.6](#), this bit will set once per SLC-96 multiframe (72 frames) to alert the host that new data may be written to the [T1TSLC1:T1TSLC3](#) registers. See Section [8.9.4.4](#) for more information.

Bit 3 (T1 Mode): Transmit Pulse Density Violation Event (TPDV). Set when the transmit data stream does not meet the ANSI T1.403 requirements for pulse density.

Bit 3 (E1 Mode): Transmit Align Frame Event (TAF). Set every 250µs to alert the host that the [E1TAF](#) and [E1TNAF](#) registers need to be updated.

Bit 2: Transmit Multiframe Event (TMF). In T1 mode, this bit is set every 1.5ms on D4 MF boundaries or every 3ms on ESF MF boundaries. In E1 operation, this bit is set every 2ms (regardless if CRC-4 is enabled) on transmit multiframe boundaries. Used to alert the host that signaling data needs to be updated.

Bit 1: Loss of Transmit Clock Condition Clear (LOTCC). Set when the LOTC condition has cleared (a clock has been sensed at the TCLK pin).

Bit 0: Loss of Transmit Clock Condition (LOTCC). Set when the TCLK pin has not transitioned for approximately 3 clock periods. Will force the LOTC bit high if enabled. This bit can be cleared by the host even if the condition is still present. LOTC will remain high while the condition exists, even if the host has cleared the status bit. If enabled by [TIM1.0](#), the $\overline{\text{INTB}}$ pin will transition low when this bit is set, and transition high when this bit is cleared (if no other unmasked interrupt conditions exist).

Register Name: **TLS2**
 Register Description: **Transmit Latched Status Register 2 (HDLC)**
 Register Address: **191h + (200h x n): where n = 0 to 3, for Ports 1 to 4**

Bit #	7	6	5	4	3	2	1	0
Name	—	—	—	TFDLE	TUDR	TMEND	TLWMS	TNFS
	—	—	—	—	TUDR	TMEND	TLWMS	TNFS
Default	0	0	0	0	0	0	0	0

Note: All bits in this register are latched and can create interrupts.

Bit 4: Transmit FDL Register Empty (TFDLE) (T1 Mode Only). Set when the TFDL register has shifted out all 8 bits. Useful if the user wants to manually use the TFDL register to send messages, instead of using the HDLC or BOC controller circuits.

Bit 3: Transmit FIFO Underrun Event (TUDR). Set when the transmit FIFO empties out without having seen the TMEND bit set. An abort is automatically sent.

Bit 2: Transmit Message End Event (TMEND). Set when the transmit HDLC controller has finished sending a message.

Bit 1: Transmit FIFO Below Low Watermark Set Condition (TLWMS). Set when the transmit 64-byte FIFO empties beyond the low watermark as defined by the transmit low watermark bit (TLWM), rising edge detect of TLWM.

Bit 0: Transmit FIFO Not Full Set Condition (TNFS). Set when the transmit 64-byte FIFO has at least one empty byte available for write. Rising edge detect of TNF. Indicates change of state from full to not full.

Register Name: **TLS3**
 Register Description: **Transmit Latched Status Register 3 (Synchronizer)**
 Register Address: **192h + (200h x n): where n = 0 to 3, for Ports 1 to 4**

Bit #	7	6	5	4	3	2	1	0
Name	—	—	—	—	—	—	LOF	LOFD
Default	0	0	0	0	0	0	0	0

Note: Some bits in this register are latched and can create interrupts.

Bit 1: Loss of Frame (LOF). A real-time bit that indicates that the transmit synchronizer is searching for the sync pattern in the incoming data stream.

Bit 0: Loss of Frame Synchronization Detect (LOFD). This latched bit is set when the transmit synchronizer is searching for the sync pattern in the incoming data stream.

Register Name: **TIIR**
 Register Description: **Transmit Interrupt Information Register**
 Register Address: **19Fh + (200h x n): where n = 0 to 3, for Ports 1 to 4**

Bit #	7	6	5	4	3	2	1	0
Name	—	—	—	—	—	TLS3	TLS2	TLS1
Default	0	0	0	0	0	0	0	0

The Transmit Interrupt Information register provides an indication of which status registers are generating an interrupt. When an interrupt occurs, the host can read TIIR to quickly identify which of the transmit status registers are causing the interrupt(s). These are real-time registers in that the bits will clear once the appropriate interrupt has been serviced and cleared.

Bit 2: Transmit Latched Status Register 3 Interrupt Status (TLS3).

0 = no interrupt pending
 1 = interrupt pending

Bit 1: Transmit Latched Status Register 2 Interrupt Status (TLS2).

0 = no interrupt pending
 1 = interrupt pending

Bit 0: Transmit Latched Status Register 1 Interrupt Status (TLS1).

0 = no interrupt pending
 1 = interrupt pending

Register Name: **TIM1**
 Register Description: **Transmit Interrupt Mask Register 1**
 Register Address: **1A0h + (200h x n): where n = 0 to 3, for Ports 1 to 4**

Bit #	7	6	5	4	3	2	1	0
Name	TESF	TESEM	TSLIP	TSLC96	TPDV	TMF	LOTCC	LOTCC
	<i>TESF</i>	<i>TESEM</i>	<i>TSLIP</i>	—	<i>TAF</i>	<i>TMF</i>	<i>LOTCC</i>	<i>LOTCC</i>
Default	0	0	0	0	0	0	0	0

Bit 7: Transmit Elastic Store Full Event (TESF).

0 = interrupt masked
 1 = interrupt enabled

Bit 6: Transmit Elastic Store Empty Event (TESEM).

0 = interrupt masked
 1 = interrupt enabled

Bit 5: Transmit Elastic Store Slip Occurrence Event (TSLIP).

0 = interrupt masked
 1 = interrupt enabled

Bit 4: Transmit SLC-96 Multiframe Event (TSLC96) (T1 Mode Only).

0 = interrupt masked
 1 = interrupt enabled

Bit 3 (T1 Mode): Transmit Pulse Density Violation Event (TPDV).

0 = interrupt masked
 1 = interrupt enabled

Bit 3 (E1 Mode): Transmit Align Frame Event (TAF).

0 = interrupt masked
 1 = interrupt enabled

Bit 2: Transmit Multiframe Event (TMF).

0 = interrupt masked
 1 = interrupt enabled

Bit 1: Loss of Transmit Clock Clear Condition (LOTCC).

0 = interrupt masked
 1 = interrupt enabled

Bit 0: Loss of Transmit Clock Condition (LOTCC).

0 = interrupt masked
 1 = interrupt enabled

Register Name: **TIM2**
 Register Description: **Transmit Interrupt Mask Register 2 (HDLC)**
 Register Address: **1A1h + (200h x n): where n = 0 to 3, for Ports 1 to 4**

Bit #	7	6	5	4	3	2	1	0
Name	—	—	—	TFDLE	TUDR	TMEND	TLWMS	TNFS
	—	—	—	—	TUDR	TMEND	TLWMS	TNFS
Default	0	0	0	0	0	0	0	0

Bit 4: Transmit FDL Register Empty (TFDLE) (T1 Mode Only).

0 = interrupt masked
 1 = interrupt enabled

Bit 3: Transmit FIFO Underrun Event (TUDR).

0 = interrupt masked
 1 = interrupt enabled

Bit 2: Transmit Message End Event (TMEND).

0 = interrupt masked
 1 = interrupt enabled

Bit 1: Transmit FIFO Below Low Watermark Set Condition (TLWMS).

0 = interrupt masked
 1 = interrupt enabled

Bit 0: Transmit FIFO Not Full Set Condition (TNFS).

0 = interrupt masked
 1 = interrupt enabled

Register Name: **TIM3**
 Register Description: **Transmit Interrupt Mask Register 3 (Synchronizer)**
 Register Address: **1A2h + (200h x n): where n = 0 to 3, for Ports 1 to 4**

Bit #	7	6	5	4	3	2	1	0
Name	—	—	—	—	—	—	—	LOFD
Default	0	0	0	0	0	0	0	0

Bit 0: Loss of Frame Synchronization Detect (LOFD).

0 = interrupt masked
 1 = interrupt enabled

Register Name: **T1TCD1 (T1 Mode Only)**
 Register Description: **Transmit Code Definition Register 1**
 Register Address: **1ACh + (200h x n): where n = 0 to 3, for Ports 1 to 4**

Bit #	7	6	5	4	3	2	1	0
Name	C7	C6	C5	C4	C3	C2	C1	C0
Default	0	0	0	0	0	0	0	0

Bit 7: Transmit Code Definition Bit 7 (C7). First bit of the repeating pattern.

Bit 6: Transmit Code Definition Bit 6 (C6).

Bit 5: Transmit Code Definition Bit 5 (C5).

Bit 4: Transmit Code Definition Bit 4 (C4).

Bit 3: Transmit Code Definition Bit 3 (C3).

Bit 2: Transmit Code Definition Bit 2 (C2). A Don't Care if a 5-bit length is selected.

Bit 1: Transmit Code Definition Bit 1 (C1). A Don't Care if a 5- or 6-bit length is selected.

Bit 0: Transmit Code Definition Bit 0 (C0). A Don't Care if a 5-, 6-, or 7-bit length is selected.

Register Name: **T1TCD2 (T1 Mode Only)**
 Register Description: **Transmit Code Definition Register 2**
 Register Address: **1ADh + (200h x n): where n = 0 to 3, for Ports 1 to 4**

Bit #	7	6	5	4	3	2	1	0
Name	C7	C6	C5	C4	C3	C2	C1	C0
Default	0	0	0	0	0	0	0	0

Bit 7: Transmit Code Definition Bit 7 (C7). A Don't Care if a 5-, 6-, or 7-bit length is selected.

Bit 6: Transmit Code Definition Bit 6 (C6). A Don't Care if a 5-, 6-, or 7-bit length is selected.

Bit 5: Transmit Code Definition Bit 5 (C5). A Don't Care if a 5-, 6-, or 7-bit length is selected.

Bit 4: Transmit Code Definition Bit 4 (C4). A Don't Care if a 5-, 6-, or 7-bit length is selected.

Bit 3: Transmit Code Definition Bit 3 (C3). A Don't Care if a 5-, 6-, or 7-bit length is selected.

Bit 2: Transmit Code Definition Bit 2 (C2). A Don't Care if a 5-, 6-, or 7-bit length is selected.

Bit 1: Transmit Code Definition Bit 1 (C1). A Don't Care if a 5-, 6-, or 7-bit length is selected.

Bit 0: Transmit Code Definition Bit 0 (C0). A Don't Care if a 5-, 6-, or 7-bit length is selected.

Register Name: **TRTS2**
 Register Description: **Transmit Real-Time Status Register 2 (HDLC)**
 Register Address: **1B1h + (200h x n): where n = 0 to 3, for Ports 1 to 4**

Bit #	7	6	5	4	3	2	1	0
Name	—	—	—	—	EMPTY	TFULL	TLWM	TNF
Default	0	0	0	0	0	0	0	0

Note: All bits in this register are real time.

Bit 3: Transmit FIFO Empty (EMPTY). A real-time bit that is set high when the FIFO is empty.

Bit 2: Transmit FIFO Full (TFULL). A real-time bit that is set high when the FIFO is full.

Bit 1: Transmit FIFO Below Low Watermark Condition (TLWM). Set when the transmit 64-byte FIFO empties beyond the low watermark as defined by the transmit low watermark bits (TLWM).

Bit 0: Transmit FIFO Not Full Condition (TNF). Set when the transmit 64-byte FIFO has at least one byte available.

Register Name: **TFBA**
 Register Description: **Transmit HDLC FIFO Buffer Available**
 Register Address: **1B3h + (200h x n): where n = 0 to 3, for Ports 1 to 4**

Bit #	7	6	5	4	3	2	1	0
Name	—	TFBA6	TFBA5	TFBA4	TFBA3	TFBA2	TFBA1	TFBA0
Default	0	0	0	0	0	0	0	0

Bits 6 to 0: Transmit FIFO Bytes Available (TFBA[6:0]). TFBA0 is the LSB.

Register Name: **THF**
 Register Description: **Transmit HDLC FIFO Register**
 Register Address: **1B4h + (200h x n): where n = 0 to 3, for Ports 1 to 4**

Bit #	7	6	5	4	3	2	1	0
Name	THD7	THD6	THD5	THD4	THD3	THD2	THD1	THD0
Default	0	0	0	0	0	0	0	0

Bit 7: Transmit HDLC Data Bit 7 (THD7). MSB of an HDLC packet data byte.

Bit 6: Transmit HDLC Data Bit 6 (THD6).

Bit 5: Transmit HDLC Data Bit 5 (THD5).

Bit 4: Transmit HDLC Data Bit 4 (THD4).

Bit 3: Transmit HDLC Data Bit 3 (THD3).

Bit 2: Transmit HDLC Data Bit 2 (THD2).

Bit 1: Transmit HDLC Data Bit 1 (THD1).

Bit 0: Transmit HDLC Data Bit 0 (THD0). LSB of an HDLC packet data byte.

Register Name: **TDS0M**
 Register Description: **Transmit DS0 Monitor Register**
 Register Address: **1BBh + (200h x n): where n = 0 to 3, for Ports 1 to 4**

Bit #	7	6	5	4	3	2	1	0
Name	B1	B2	B3	B4	B5	B6	B7	B8
Default	0	0	0	0	0	0	0	0

Bits 7 to 0: Transmit DS0 Channel Bits (B[1:8]). Transmit channel data that has been selected by the Transmit DS0 Channel Monitor Select register ([TDS0SEL](#)). B8 is the LSB of the DS0 channel (last bit to be transmitted).

Register Name: **TBCS1, TBCS2, TBCS3, TBCS4**
 Register Description: **Transmit Blank Channel Select Registers 1 to 4**
 Register Address: **1C0h, 1C1h, 1C2h, 1C3h + (200h x n): where n = 0 to 3, for Ports 1 to 4**

Bit #	(MSB) 7	6	5	4	3	2	1	0 (LSB)	
Name	CH8	CH7	CH6	CH5	CH4	CH3	CH2	CH1	TBCS1
	CH16	CH15	CH14	CH13	CH12	CH11	CH10	CH9	TBCS2
	CH24	CH23	CH22	CH21	CH20	CH19	CH18	CH17	TBCS3
	<i>CH32</i>	<i>CH31</i>	<i>CH30</i>	<i>CH29</i>	<i>CH28</i>	<i>CH27</i>	<i>CH26</i>	<i>CH25</i>	TBCS4 (E1 Mode Only)
Default	0	0	0	0	0	0	0	0	

Bits 7 to 0: Transmit Blank Channel Select for Channels 1 to 32 (CH[1:32]).

0 = transmit TSER data from this channel

1 = ignore TSER data from this channel

Note that when two or more sequential channels are chosen to be ignored, the receive slip zone select bit should be set to zero. If the ignore channels are distributed (such as 1, 5, 9, 13, 17, 21, 25, 29), the RSZS bit can be set to one, which may provide a lower occurrence of slips in certain applications.

Register Name: **TCBR1, TCBR2, TCBR3, TCBR4**
 Register Description: **Transmit Channel Blocking Registers 1 to 4**
 Register Address: **1C4h, 1C5h, 1C6h, 1C7h + (200h x n): where n = 0 to 3, for Ports 1 to 4**

Bit #	(MSB)							(LSB)	
Name	CH8	CH7	CH6	CH5	CH4	CH3	CH2	CH1	TCBR1
	CH16	CH15	CH14	CH13	CH12	CH11	CH10	CH9	TCBR2
	CH24	CH23	CH22	CH21	CH20	CH19	CH18	CH17	TCBR3
	CH32	CH31	CH30	CH29	CH28	CH27	CH26	CH25 (F-bit)	TCBR4* (E1 Mode Only)
Default	0	0	0	0	0	0	0	0	

Bits 7 to 0: Transmit Channel Blocking Channels 1 to 32 Control Bits (CH[1:32]).

0 = force the TCHBLK pin to remain low during this channel time

1 = force the TCHBLK pin high during this channel time

***Note that TCBR4 has two functions:**

When 2.048MHz backplane mode is selected, this register allows the user to enable the channel blocking signal for any of the 32 possible backplane channels.

When 1.544MHz backplane mode is selected, the LSB of this register determines whether or not the TCHBLK signal will pulse high during the F-bit time:

TCBR4.0 = 0: Do not pulse TCHBLK during the F-bit.

TCBR4.0 = 1: Pulse TCHBLK during the F-bit.

In this mode, TCBR4.1 to TCBR4.7 should be set to 0.

Register Name: **THSCS1, THSCS2, THSCS3, THSCS4**
 Register Description: **Transmit Hardware-Signaling Channel Select Registers 1 to 4**
 Register Address: **1C8h, 1C9h, 1CAh, 1CBh + (200h x n): where n = 0 to 3, for Ports 1 to 4**

Bit #	(MSB) 7	6	5	4	3	2	1	0 (LSB)	
Name	CH8	CH7	CH6	CH5	CH4	CH3	CH2	CH1	THSCS1
	CH16	CH15	CH14	CH13	CH12	CH11	CH10	CH9	THSCS2
	CH24	CH23	CH22	CH21	CH20	CH19	CH18	CH17	THSCS3
	CH32	CH31	CH30	CH29	CH28	CH27	CH26	CH25	THSCS4* (E1 Mode Only)
Default	0	0	0	0	0	0	0	0	

Bits 7 to 0: Transmit Hardware-Signaling Channel Select for Channels 1 to 32 (CH[1:32]). These bits determine which channels have signaling data inserted from the TSIG pin into the TSER PCM data.

0 = do not source signaling data from the TSIG pin for this channel

1 = source signaling data from the TSIG pin for this channel

***Note that THSCS4 is only used in 2.048MHz backplane applications.**

Register Name: **TGCCS1, TGCCS2, TGCCS3, TGCCS4**
 Register Description: **Transmit Gapped-Clock Channel Select Registers 1 to 4**
 Register Address: **1CCh, 1CDh, 1CEh, 1CFh + (200h x n): where n = 0 to 3, for Ports 1 to 4**

Bit #	(MSB)							(LSB)	
Name	CH8	CH7	CH6	CH5	CH4	CH3	CH2	CH1	TGCCS1
	CH16	CH15	CH14	CH13	CH12	CH11	CH10	CH9	TGCCS2
	CH24	CH23	CH22	CH21	CH20	CH19	CH18	CH17	TGCCS3
	CH32	CH31	CH30	CH29	CH28	CH27	CH26	CH25 (F-bit)	TGCCS4* (E1 Mode Only)
Default	0	0	0	0	0	0	0	0	

Bits 7 to 0: Transmit Gapped-Clock Channel Select Channels 1 to 32 (CH[1:32]).

0 = no clock is present on TCHCLK during this channel time

1 = force a clock on TCHCLK during this channel time. The clock will be synchronous with TCLK if the elastic store is disabled, and synchronous with TSYCLK if the elastic store is enabled.

***Note that TGCCS4 has two functions:**

When 2.048MHz backplane mode is selected, this register allows the user to enable the gapped clock on TCHCLK for any of the 32 possible backplane channels.

When 1.544MHz backplane mode is selected, the LSB of this register determines whether or not a clock is generated on TCHCLK during the F-bit time:

TGCCS4.0 = 0: Do not generate a clock during the F-bit

TGCCS4.0 = 1: Generate a clock during the F-bit

In this mode, TGCCS4.1 to TGCCS4.7 should be set to 0.

Register Name: **PCL1, PCL2, PCL3, PCL4**
 Register Description: **Per-Channel Loopback Enable Registers 1 to 4**
 Register Address: **1D0h, 1D1h, 1D2h, 1D3h + (200h x n): where n = 0 to 3, for Ports 1 to 4**

Bit #	(MSB)							(LSB)	
Name	CH8	CH7	CH6	CH5	CH4	CH3	CH2	CH1	PCL1
	CH16	CH15	CH14	CH13	CH12	CH11	CH10	CH9	PCL2
	CH24	CH23	CH22	CH21	CH20	CH19	CH18	CH17	PCL3
	<i>CH32</i>	<i>CH31</i>	<i>CH30</i>	<i>CH29</i>	<i>CH28</i>	<i>CH27</i>	<i>CH26</i>	<i>CH25</i>	PCL4 (E1 Mode Only)
Default	0	0	0	0	0	0	0	0	

Bits 7 to 0: Per-Channel Loopback Enable for Channels 1 to 32 (CH[1:32]).

0 = loopback disabled

1 = enable loopback; source data from the corresponding receive channel

Register Name: **TBPCS1, TBPCS2, TBPCS3, TBPCS4**
 Register Description: **Transmit BERT Port Channel Select Registers 1 to 4**
 Register Address: **1D4h, 1D5h, 1D6h, 1D7h + (200h x n): where n = 0 to 3, for Ports 1 to 4**

Bit #	(MSB) 7	6	5	4	3	2	1	0 (LSB)	
Name	CH8	CH7	CH6	CH5	CH4	CH3	CH2	CH1	TBPCS1
	CH16	CH15	CH14	CH13	CH12	CH11	CH10	CH9	TBPCS2
	CH24	CH23	CH22	CH21	CH20	CH19	CH18	CH17	TBPCS3
	<i>CH32</i>	<i>CH31</i>	<i>CH30</i>	<i>CH29</i>	<i>CH28</i>	<i>CH27</i>	<i>CH26</i>	<i>CH25</i>	TBPCS4 (E1 Mode Only)
Default	0	0	0	0	0	0	0	0	

Setting any of the CH[1:32] bits in the TBPCS1:TBPCS4 registers will enable the transmit BERT clock for the associated channel time, and allow mapping of the selected channel data out of the receive BERT port. Multiple or all channels can be selected simultaneously.

9.5 LIU Register Definitions

Table 9-14. LIU Register Set

ADDRESS	NAME	DESCRIPTION	R/W
1000h	LTRCR	LIU Transmit Receive Control Register	R/W
1001h	LTITSR	LIU Transmit Impedance and Pulse Shape Selection Register	R/W
1002h	LMCR	LIU Maintenance Control Register	R/W
1003h	LRSR	LIU Real Status Register	R
1004h	LSIMR	LIU Status Interrupt Mask Register	R/W
1005h	LLSR	LIU Latched Status Register	R/W
1006h	LRSL	LIU Receive Signal Level Register	R
1007h	LRISMR	LIU Receive Impedance and Sensitivity Monitor Register	R/W
1008h–101Fh	—	Reserved	—

Note: Reserved registers should only be written with all zeros.

Register Name: **LTRCR**
 Register Description: **LIU Transmit Receive Control Register**
 Register Address: **1000h + (20h x n): where n = 0 to 3, for Ports 1 to 4**

Bit #	7	6	5	4	3	2	1	0
Name	—	—	—	JADS	JAPS1	JAPS0	T1J1E1S	LSC
Default	0	0	0	0	0	0	0	0

Bit 4: Jitter Attenuator Depth Select (JADS).

0 = Jitter attenuator FIFO depth set to 128 bits.

1 = Jitter attenuator FIFO depth set to 32 bits. Use for delay-sensitive applications.

Bits 3 and 2: Jitter Attenuator Position Select 1 and 0 (JAPS[1:0]). These bits are used to select the position of the jitter attenuator.

JAPS1	JAPS0	FUNCTION
0	0	Jitter attenuator is in the receive path.
0	1	Jitter attenuator is in the transmit path.
1	0	Jitter attenuator is not used.
1	1	Jitter attenuator is not used.

Bit 1: T1J1E1 Selection (T1J1E1S). This bit configures the LIU for E1 or T1/J1 operation.

0 = E1

1 = T1 or J1

Bit 0: LOS Criteria Selection (LCS). This bit is used for LIU LOS selection criteria.

E1 Mode:

0 = G.775

1 = ETS 300 233

T1/J1 Mode:

0 = T1.231

1 = T1.231

Register Name: **LTITSR**
 Register Description: **LIU Transmit Impedance and Pulse Shape Selection Register**
 Register Address: **1001h + (20h x n): where n = 0 to 3, for Ports 1 to 4**

Bit #	7	6	5	4	3	2	1	0
Name	—	TIMPTOFF	TIMPL1	TIMPL0	—	L2	L1	L0
Default	0	0	0	0	0	0	0	0

Bit 6: Transmit Impedance Off (TIMPTOFF).

- 0 = Enable transmit terminating impedance.
- 1 = Disable transmit terminating impedance.

Bits 5 and 4: Transmit Load Impedance 1 and 0 (TIMPL[1:0]). These bits are used to select the transmit load impedance. These must be set to match the cable impedance. Even if the internal load impedance is turned off (via TIMPTOFF); the external cable impedance must be specified for optimum operation. For J1 applications, use 110Ω. See [Table 9-15](#).

Bits 2 to 0: Line Build-Out Select 2 to 0 (L[2:0]). Used to select the transmit waveshape. The waveshape has a voltage level and load impedance associated with it once the T1/J1 or E1 selection is made by settings in the [LTRCR](#) register. See [Table 9-16](#).

Table 9-15. Transmit Load Impedance Selection

TIMPL1	TIMPL0	IMPEDANCE SELECTION
0	0	75Ω
0	1	100Ω
1	0	110Ω
1	1	120Ω

Table 9-16. Transmit Pulse Shape Selection

L2	L1	L0	MODE	IMPEDANCE	NOMINAL VOLTAGE
0	0	0	E1	75Ω	2.37V
0	0	1	E1	120Ω	3.0V

L2	L1	L0	MODE	CABLE LENGTH	MAX ALLOWED CABLE LOSS
0	0	0	T1/J1	DSX-1/0dB CSU, 0ft–133ft ABAM 100Ω	0.6dB
0	0	1	T1/J1	DSX-1, 133ft–266ft ABAM 100Ω	1.2dB
0	1	0	T1/J1	DSX-1, 266ft–399ft ABAM 100Ω	1.8dB
0	1	1	T1/J1	DSX-1, 399ft–533ft ABAM 100Ω	2.4dB
1	0	0	T1/J1	DSX-1, 533ft–655ft ABAM 100Ω	3.0dB
1	0	1	T1/J1	-7.5dB CSU	—
1	1	0	T1/J1	-15dB CSU	—
1	1	1	T1/J1	-22.5dB CSU	—

Register Name: **LMCR**
 Register Description: **LIU Maintenance Control Register**
 Register Address: **1002h + (20h x n): where n = 0 to 3, for Ports 1 to 4**

Bit #	7	6	5	4	3	2	1	0
Name	TAIS	ATAIS	LLB	ALB	RLB	TPDE	RPDE	TE
Default	0	0	0	0	0	0	0	0

Bit 7: Transmit AIS (TAIS). Alarm Indication Signal (AIS) is sent using MCLK as the reference clock. The transmit data coming from the framer is ignored.

0 = TAIS is disabled.

1 = Output an unframed all-ones pattern (AIS) at TTIP and TRING.

Bit 6: Automatic Transmit AIS (ATAIS).

0 = ATAIS is disabled.

1 = Automatically transmit AIS on the occurrence of an LIU LOS.

Bit 5: Local Loopback (LLB). See Section [8.11.5.2](#) for operational details.

0 = LLB is disabled.

1 = LLB is enabled.

Bit 4: Analog Loopback (ALB). See Section [8.11.5.1](#) for operational details.

0 = ALB is disabled.

1 = ALB is enabled.

Bit 3: Remote Loopback (RLB). See Section [8.11.5.3](#) for operational details.

0 = Remote loopback is disabled.

1 = Remote loopback is enabled.

In this loopback, received data passes all the way through the receive LIU and is then transmitted back through the transmit side of the LIU. Data will continue to pass through the receive-side framer of the DS26524 as it would normally and the data from the transmit side of the framer will be ignored.

Bit 2: Transmit Power-Down Enable (TPDE).

0 = Transmitter power enabled.

1 = Transmitter powered down. TTIP/TRING outputs are high impedance.

Bit 1: Receiver Power-Down Enable (RPDE).

0 = Receiver power enabled.

1 = Receiver powered down.

Bit 0: Transmit Enable (TE). This function is overridden by the TXENABLE pin.

0 = TTIP/TRING outputs are high impedance.

1 = TTIP/TRING outputs enabled.

Register Name: **LRSR**
 Register Description: **LIU Real Status Register**
 Register Address: **1003h + (20h x n): where n = 0 to 3, for Ports 1 to 4**

Bit #	7	6	5	4	3	2	1	0
Name	—	—	OEQ	UEQ	—	SCS	OCS	LOSS
Default	0	0	0	0	0	0	0	0

Bit 5: Over Equalized (OEQ). The equalizer is over equalized. This can happen if there is very large unexpected resistive loss. This could result if monitor mode is used and the device is not placed in monitor mode. This indicator provides more qualitative information to the receive loss indicators.

Bit 4: Under Equalized (UEQ). The equalizer is under equalized. A signal with a very high resistive gain is being applied. This indicator provides more qualitative information to the receive loss indicators.

Bit 2: Short-Circuit Status (SCS). A real-time bit that is set when the LIU detects that the TTIP and TRING outputs are short-circuited. The load resistance must be 25Ω (typically) or less for short-circuit detection.

Bit 1: Open-Circuit Status (OCS). A real-time bit that is set when the LIU detects that the TTIP and TRING outputs are open-circuited.

Bit 0: Loss-of-Signal Status (LOSS). A real-time bit that is set when the LIU detects a LOS condition at RTIP and RRING.

Register Name: **LSIMR**
 Register Description: **LIU Status Interrupt Mask Register**
 Register Address: **1004h + (20h x n): where n = 0 to 3, for Ports 1 to 4**

Bit #	7	6	5	4	3	2	1	0
Name	JALTCIM	OCCIM	SCCIM	LOSCIM	JALTSIM	OCDIM	SCDIM	LOSDIM
Default	0	0	0	0	0	0	0	0

Bit 7: Jitter Attenuator Limit Trip Clear Interrupt Mask (JALTCIM).

0 = Interrupt masked.
 1 = Interrupt enabled.

Bit 6: Open-Circuit Clear Interrupt Mask (OCCIM).

0 = Interrupt masked.
 1 = Interrupt enabled.

Bit 5: Short-Circuit Clear Interrupt Mask (SCCIM).

0 = Interrupt masked.
 1 = Interrupt enabled.

Bit 4: Loss of Signal Clear Interrupt Mask (LOSCIM).

0 = Interrupt masked.
 1 = Interrupt enabled.

Bit 3: Jitter Attenuator Limit Trip Set Interrupt Mask (JALTSIM).

0 = Interrupt masked.
 1 = Interrupt enabled.

Bit 2: Open-Circuit Detect Interrupt Mask (OCDIM).

0 = Interrupt masked.
 1 = Interrupt enabled.

Bit 1: Short-Circuit Detect Interrupt Mask (SCDIM).

0 = Interrupt masked.
 1 = Interrupt enabled.

Bit 0: Loss of Signal Detect Interrupt Mask (LOSDIM).

0 = Interrupt masked.
 1 = Interrupt enabled.

Register Name: **LLSR**
 Register Description: **LIU Latched Status Register**
 Register Address: **1005h + (20h x n): where n = 0 to 3, for Ports 1 to 4**

Bit #	7	6	5	4	3	2	1	0
Name	JALTC	OCC	SCC	LOSC	JALTS	OCD	SCD	LOSD
Default	0	0	0	0	0	0	0	0

Note: All bits in this register are latched and can create interrupts.

Bit 7: Jitter Attenuator Limit Trip Clear (JALTC). This latched bit is set when a jitter attenuator limit trip condition was detected and then removed.

Bit 6: Open-Circuit Clear (OCC). This latched bit is set when an open-circuit condition was detected at TTIP and TRING and then removed.

Bit 5: Short-Circuit Clear (SCC). This latched bit is set when a short-circuit condition was detected at TTIP and TRING and then removed.

Bit 4: Loss of Signal Clear (LOSC). This latched bit is set when a loss-of-signal condition was detected at RTIP and RRING and then removed.

Bit 3: Jitter Attenuator Limit Trip Set (JALTS). This latched bit is set when the jitter attenuator limit trip condition is detected.

Bit 2: Open-Circuit Detect (OCD). This latched bit is set when an open-circuit condition is detected at TTIP and TRING. This bit is not functional in T1 CSU operating modes (T1 LBO 5, LBO 6, and LBO 7).

Bit 1: Short-Circuit Detect (SCD). This latched bit is set when a short-circuit condition is detected at TTIP and TRING. This bit is not functional in T1 CSU operating modes (T1 LBO 5, LBO 6, and LBO 7).

Bit 0: Loss of Signal Detect (LOSD). This latched bit is set when an LOS condition is detected at RTIP and RRING.

Register Name: **LRSL**
 Register Description: **LIU Receive Signal Level Register**
 Register Address: **1006h + (20h x n): where n = 0 to 3, for Ports 1 to 4**

Bit #	7	6	5	4	3	2	1	0
Name	RSL3	RSL2	RLS1	RLS0	—	—	—	—
Default	0	0	0	0	0	0	0	0

Bits 7 to 4: Receiver Signal Level 3 to 0 (RSL[3:0]). Real-time receive signal level as shown in [Table 9-17](#). Note that the range of signal levels reported the RSL[3:0] is limited by the Equalizer Gain Limit (EGL) in short-haul applications.

Table 9-17. Receive Level Indication

RSL3	RSL2	RSL1	RSL0	RECEIVE LEVEL (dB)	
				T1	E1
0	0	0	0	> -2.5	> -2.5
0	0	0	1	-2.5 to -5	-2.5 to -5
0	0	1	0	-5 to -7.5	-5 to -7.5
0	0	1	1	-7.5 to -10	-7.5 to -10
0	1	0	0	-10 to -12.5	-10 to -12.5
0	1	0	1	-12.5 to -15	-12.5 to -15
0	1	1	0	-15 to -17.5	-15 to -17.5
0	1	1	1	-17.5 to -20	-17.5 to -20
1	0	0	0	-20 to -23	-20 to -23
1	0	0	1	-23 to -26	-23 to -26
1	0	1	0	-26 to -29	-26 to -29
1	0	1	1	-29 to -32	-29 to -32
1	1	0	0	-32 to -36	-32 to -36
1	1	0	1	< -36	-36 to -40
1	1	1	0	—	-40 to -44
1	1	1	1	—	< -44

Register Name: **LRISMR**
 Register Description: **LIU Receive Impedance and Sensitivity Monitor Register**
 Register Address: **1007h + (20h x n): where n = 0 to 3, for Ports 1 to 4**

Bit #	7	6	5	4	3	2	1	0
Name	RG703	RIMPOFF	RIMPM1	RIMPM0	RTR	RMONEN	RSMS1	RSMS0
Default	0	0	0	0	0	0	0	0

Bit 7: Receive G.703 Clock Enable (RG703). If this bit is set, the receiver expects a 2.048MHz or 1.544MHz clock from the RTIP/RRING, based on the selection of T1 (1.544) or E1 (2.048) mode in the [LTRCR](#) register.

Bit 6: Receive Impedance Termination Off (RIMPOFF).
 0 = Receive terminating impedance match is enabled.
 1 = Receive terminating impedance match is disabled.

Bits 5 and 4: Receive Impedance Match 1 and 0 (RIMPM[1:0]). These bits are used to select the receive impedance match value. These must be set according to the cable impedance. Even if the internal receive match impedance is turned off (RIMPOFF); the external cable impedance must be specified for optimum operation by RIMPM1 to 0. See [Table 9-18](#).

Bit 3: Receiver Turns Ratio (RTR).
 0 = Receive transformer turns ratio is 1:1.
 1 = Receive transformer turns ratio is 2:1. This option should only be used in short-haul applications.

Bit 2: Receiver Monitor Mode Enable (RMONEN).
 0 = Disable receive monitor mode.
 1 = Enable receive monitor mode. Resistive gain is added with the maximum sensitivity. The receiver sensitivity is determined by RSMS1 and RSMS0.

Bits 1 and 0: Receiver Sensitivity/Monitor Gain Select 1 and 0 (RSMS[1:0]). These bits are used to select the receiver sensitivity level and additional gain in monitoring applications. The monitor mode (RMONEN) adds resistive gain to compensate for the signal loss caused by the isolation resistors. See [Table 9-19](#) and [Table 9-20](#).

Table 9-18. Receive Impedance Selection

RIMPM[1:0]	RECEIVE IMPEDANCE SELECTED (Ω)
00	75
01	100
10	110
11	120

Table 9-19. Receiver Sensitivity Selection with Monitor Mode Disabled

RMONEN	RSMS[1:0]	RECEIVER MONITOR MODE GAIN (dB)	RECEIVER SENSITIVITY (MAX CABLE LOSS ALLOWED) (dB)
0	00	0	12
0	01	0	18
0	10	0	30
0	11	0	36 for T1; 43 for E1

Table 9-20. Receiver Sensitivity Selection with Monitor Mode Enabled

RMONEN	RSMS[1:0]	RECEIVER MONITOR MODE GAIN (dB)	RECEIVER SENSITIVITY (MAX CABLE LOSS ALLOWED) (dB)
1	00	14	30
1	01	20	22.5
1	10	26	17.5
1	11	32	12

9.6 BERT Register Definitions

Table 9-21. BERT Register Set

ADDR	NAME	DESCRIPTION	R/W
1100h	BAWC	BERT Alternating Word Count Rate Register	R
1101h	BRP1	BERT Repetitive Pattern Set Register 1	R/W
1102h	BRP2	BERT Repetitive Pattern Set Register 2	R/W
1103h	BRP3	BERT Repetitive Pattern Set Register 3	R/W
1104h	BRP4	BERT Repetitive Pattern Set Register 4	R/W
1105h	BC1	BERT Control Register 1	R/W
1106h	BC2	BERT Control Register 2	R/W
1107h	BBC1	BERT Bit Count Register 1	R
1108h	BBC2	BERT Bit Count Register 2	R
1109h	BBC3	BERT Bit Count Register 3	R
110Ah	BBC4	BERT Bit Count Register 4	R
110Bh	BEC1	BERT Error Count Register 1	R
110Ch	BEC2	BERT Error Count Register 2	R
110Dh	BEC3	BERT Error Count Register 3	R
110Eh	BLSR	BERT Latched Status Register	R
110Fh	BSIM	BERT Status Interrupt Mask Register	R/W

Register Name: **BAWC**
 Register Description: **BERT Alternating Word Count Rate Register**
 Register Address: **1100h + (10h x n): where n = 0 to 3, for Ports 1 to 4**

Bit #	7	6	5	4	3	2	1	0
Name	ACNT7	ACNT6	ACNT5	ACNT4	ACNT3	ACNT2	ACNT1	ACNT0
Default	0	0	0	0	0	0	0	0

Bits 7 to 0: Alternating Word Count Rate Bits 7 to 0 (ACNT[7:0]). When the BERT is programmed in the alternating word mode, the words will repeat for the count loaded into this register, then flip to the other word and again repeat for the number of times loaded into this register. ACNT0 is the LSB of the 8-bit alternating word count rate counter.

Register Name: **BRP1**
 Register Description: **BERT Repetitive Pattern Set Register 1**
 Register Address: **1101h + (10h x n): where n = 0 to 3, for Ports 1 to 4**

Bit #	7	6	5	4	3	2	1	0
Name	RPAT7	RPAT6	RPAT5	RPAT4	RPAT3	RPAT2	RPAT1	RPAT0
Default	0	0	0	0	0	0	0	0

Bits 7 to 0: BERT Repetitive Pattern Set Bits 7 to 0 (RPAT[7:0]). RPAT0 is the LSB of the 32-bit repetitive pattern.

Register Name: **BRP2**
 Register Description: **BERT Repetitive Pattern Set Register 2**
 Register Address: **1102h + (10h x n): where n = 0 to 3, for Ports 1 to 4**

Bit #	7	6	5	4	3	2	1	0
Name	RPAT15	RPAT14	RPAT13	RPAT12	RPAT11	RPAT10	RPAT9	RPAT8
Default	0	0	0	0	0	0	0	0

Bits 7 to 0: BERT Repetitive Pattern Set Bits 15 to 8 (RPAT[15:8]).

Register Name: **BRP3**
 Register Description: **BERT Repetitive Pattern Set Register 3**
 Register Address: **1103h + (10h x n): where n = 0 to 3, for Ports 1 to 4**

Bit #	7	6	5	4	3	2	1	0
Name	RPAT23	RPAT22	RPAT21	RPAT20	RPAT19	RPAT18	RPAT17	RPAT16
Default	0	0	0	0	0	0	0	0

Bits 7 to 0: BERT Repetitive Pattern Set Bits 23 to 16 (RPAT[23:16]).

Register Name: **BRP4**
 Register Description: **BERT Repetitive Pattern Set Register 4**
 Register Address: **1104h + (10h x n): where n = 0 to 3, for Ports 1 to 4**

Bit #	7	6	5	4	3	2	1	0
Name	RPAT31	RPAT30	RPAT29	RPAT28	RPAT27	RPAT26	RPAT25	RPAT24
Default	0	0	0	0	0	0	0	0

Bits 7 to 0: BERT Repetitive Pattern Set Bits 31 to 24 (RPAT[31:24]). RPAT31 is the MSB of the 32-bit repetitive pattern.

Register Name: **BC1**
 Register Description: **BERT Control Register 1**
 Register Address: **1105h + (10h x n): where n = 0 to 3, for Ports 1 to 4**

Bit #	7	6	5	4	3	2	1	0
Name	TC	TINV	RINV	PS2	PS1	PS0	LC	RESYNC
Default	0	0	0	0	0	0	0	0

Bit 7: Transmit Pattern Load (TC). A low-to-high transition loads the pattern generator with the pattern that is to be generated. This bit should be toggled from low to high whenever the host wishes to load a new pattern. Must be cleared and set again for subsequent loads.

Bit 6: Transmit Invert Data Enable (TINV).

0 = do not invert the outgoing data stream
 1 = invert the outgoing data stream

Bit 5: Receive Invert Data Enable (RINV).

0 = do not invert the incoming data stream
 1 = invert the incoming data stream

Bits 4 to 2: Pattern Select Bits 2 to 0 (PS[2:0]). These bits select data pattern used by the transmit and receive circuits. See [Table 9-22](#).

Table 9-22. BERT Pattern Select

PS2	PS1	PS0	PATTERN DEFINITION
0	0	0	Pseudorandom 2E7-1
0	0	1	Pseudorandom 2E11-1
0	1	0	Pseudorandom 2E15-1
0	1	1	Pseudorandom Pattern QRSS. A $2^{20} - 1$ pattern with 14 consecutive zero restriction.
1	0	0	Repetitive Pattern
1	0	1	Alternating Word Pattern
1	1	0	Modified 55 Octet (Daly) Pattern. The Daly pattern is a repeating 55 octet pattern that is byte-aligned into the active DS0 time slots. The pattern is defined in an ATIS (Alliance for Telecommunications Industry Solutions) Committee T1 Technical Report Number 25 (November 1993).
1	1	1	Pseudorandom 2E-9-1

Bit 1: Load Bit and Error Counter (LC). A low-to-high transition latches the current bit and error counts into the registers [BBC1](#), [BBC2](#), [BBC3](#), [BBC4](#) and [BEC1](#), [BEC2](#), and [BEC3](#), and clears the internal count. This bit should be toggled from low to high whenever the host wishes to begin a new acquisition period. Must be cleared and set again for subsequent loads.

Bit 0: Force Resynchronization (RESYNC). A low-to-high transition forces the receive BERT synchronizer to resynchronize to the incoming data stream. This bit should be toggled from low to high whenever the host wishes to acquire synchronization on a new pattern. Must be cleared and set again for a subsequent resynchronization.

Register Name: **BC2**
 Register Description: **BERT Control Register 2**
 Register Address: **1106h + (10h x n): where n = 0 to 3, for Ports 1 to 4**

Bit #	7	6	5	4	3	2	1	0
Name	EIB2	EIB1	EIB0	SBE	RPL3	RPL2	RPL1	RPL0
Default	0	0	0	0	0	0	0	0

Bits 7 to 5: Error Insert Bits 2 to 0 (EIB[2:0]). Will automatically insert bit errors at the prescribed rate into the generated data pattern. Can be used for verifying error detection features. See [Table 9-23](#).

Table 9-23. BERT Error Insertion Rate

EIB2	EIB1	EIB0	ERROR RATE INSERTED
0	0	0	No errors automatically inserted
0	0	1	10E-1
0	1	0	10E-2
0	1	1	10E-3
1	0	0	10E-4
1	0	1	10E-5
1	1	0	10E-6
1	1	1	10E-7

Bit 4: Single Bit Error Insert (SBE). A low-to-high transition will create a single bit error. Must be cleared and set again for a subsequent bit error to be inserted.

Bits 3 to 0: Repetitive Pattern Length Select 3 to 0 (RPL[3:0]). RPL0 is the LSB and RPL3 is the MSB of a nibble that describes how long the repetitive pattern is. The valid range is 17 (0000) to 32 (1111). These bits are ignored if the receive BERT is programmed for a pseudorandom pattern. To create repetitive patterns fewer than 17 bits in length, the user must set the length to an integer number of the desired length that is less than or equal to 32. For example, to create a 6-bit pattern, the user can set the length to 18 (0001) or to 24 (0111) or to 30 (1101). See [Table 9-24](#).

Table 9-24. BERT Repetitive Pattern Length Select

LENGTH (BITS)	RPL3	RPL2	RPL1	RPL0
17	0	0	0	0
18	0	0	0	1
19	0	0	1	0
20	0	0	1	1
21	0	1	0	0
22	0	1	0	1
23	0	1	1	0
24	0	1	1	1
25	1	0	0	0
26	1	0	0	1
27	1	0	1	0
28	1	0	1	1
29	1	1	0	0
30	1	1	0	1
31	1	1	1	0
32	1	1	1	1

Register Name: **BBC1**
 Register Description: **BERT Bit Count Register 1**
 Register Address: **1107h + (10h x n): where n = 0 to 3, for Ports 1 to 4**

Bit #	7	6	5	4	3	2	1	0
Name	BBC7	BBC6	BBC5	BBC4	BBC3	BBC2	BBC1	BBC0
Default	0	0	0	0	0	0	0	0

Bits 7 to 0: BERT Bit Counter Bits 7 to 0 (BBC[7:0]). BBC0 is the LSB of the 32-bit counter.

Register Name: **BBC2**
 Register Description: **BERT Bit Count Register 2**
 Register Address: **1108h + (10h x n): where n = 0 to 3, for Ports 1 to 4**

Bit #	7	6	5	4	3	2	1	0
Name	BBC15	BBC14	BBC13	BBC12	BBC11	BBC10	BBC9	BBC8
Default	0	0	0	0	0	0	0	0

Bits 7 to 0: BERT Bit Counter Bits 15 to 8 (BBC[15:8]).

Register Name: **BBC3**
 Register Description: **BERT Bit Count Register 3**
 Register Address: **1109h + (10h x n): where n = 0 to 3, for Ports 1 to 4**

Bit #	7	6	5	4	3	2	1	0
Name	BBC23	BBC22	BBC21	BBC20	BBC19	BBC18	BBC17	BBC16
Default	0	0	0	0	0	0	0	0

Bits 7 to 0: BERT Bit Counter Bits 23 to 16 (BBC[23:16]).

Register Name: **BBC4**
 Register Description: **BERT Bit Count Register 4**
 Register Address: **110Ah + (10h x n): where n = 0 to 3, for Ports 1 to 4**

Bit #	7	6	5	4	3	2	1	0
Name	BBC31	BBC30	BBC29	BBC28	BBC27	BBC26	BBC25	BBC24
Default	0	0	0	0	0	0	0	0

Bits 7 to 0: BERT Bit Counter Bits 31 to 24 (BBC[31:24]). BBC31 is the MSB of the 32-bit counter.

Register Name: **BEC1**
 Register Description: **BERT Error Count Register 1**
 Register Address: **110Bh + (10h x n): where n = 0 to 3, for Ports 1 to 4**

Bit #	7	6	5	4	3	2	1	0
Name	EC7	EC6	EC5	EC4	EC3	EC2	EC1	EC0
Default	0	0	0	0	0	0	0	0

Bits 7 to 0: Error Counter Bits 7 to 0 (EC[7:0]). EC0 is the LSB of the 24-bit counter.

Register Name: **BEC2**
 Register Description: **BERT Error Count Register 2**
 Register Address: **110Ch + (10h x n): where n = 0 to 3, for Ports 1 to 4**

Bit #	7	6	5	4	3	2	1	0
Name	EC15	EC14	EC13	EC12	EC11	EC10	EC9	EC8
Default	0	0	0	0	0	0	0	0

Bits 7 to 0: Error Counter Bits 15 to 8 (EC[15:8]).

Register Name: **BEC3**
 Register Description: **BERT Error Count Register 3**
 Register Address: **110Dh + (10h x n): where n = 0 to 3, for Ports 1 to 4**

Bit #	7	6	5	4	3	2	1	0
Name	EC23	EC22	EC21	EC20	EC19	EC18	EC17	EC16
Default	0	0	0	0	0	0	0	0

Bits 7 to 0: Error Counter Bits 23 to 16 (EC[23:16]). EC23 is the MSB of the 24-bit counter.

Register Name: **BLSR**
 Register Description: **BERT Latched Status Register**
 Register Address: **110Eh + (10h x n); where n = 0 to 3, for Ports 1 to 4**

Bit #	7	6	5	4	3	2	1	0
Name	—	BBED	BBCO	BECO	BRA1	BRA0	BRLOS	BSYNC
Default	0	0	0	0	0	0	0	0

Note: All bits in this register are latched and can create interrupts.

Bit 6: BERT Bit-Error-Detected Event (BBED). A latched bit that is set when a bit error is detected. The receive BERT must be in synchronization for it to detect bit errors.

Bit 5: BERT Bit Counter Overflow Event (BBCO). A latched bit that is set when the 32-bit BERT bit counter (BBC) overflows.

Bit 4: BERT Error Counter Overflow Event (BECO). A latched bit that is set when the 24-bit BERT error counter (BEC) overflows.

Bit 3: BERT Receive All-Ones Condition (BRA1). A latched bit that is set when 32 consecutive ones are received.

Bit 2: BERT Receive All-Zeros Condition (BRA0). A latched bit that is set when 32 consecutive zeros are received.

Bit 1: BERT Receive Loss of Synchronization Condition (BRLOS). A latched bit that is set whenever the receive BERT begins searching for a pattern.

Bit 0: BERT in Synchronization Condition (BSYNC). Will be set when the incoming pattern matches for 32 consecutive bit positions.

Register Name: **BSIM**
 Register Description: **BERT Status Interrupt Mask Register**
 Register Address: **110Fh + (10h x n): where n = 0 to 3, for Ports 1 to 4**

Bit #	7	6	5	4	3	2	1	0
Name	—	BBED	BBCO	BECO	BRA1	BRA0	BRLOS	BSYNC
Default	0	0	0	0	0	0	0	0

Bit 6: BERT Bit-Error-Detected Event (BBED).

0 = interrupt masked
 1 = interrupt enabled

Bit 5: BERT Bit Counter Overflow Event (BBCO).

0 = interrupt masked
 1 = interrupt enabled

Bit 4: BERT Error Counter Overflow Event (BECO).

0 = interrupt masked
 1 = interrupt enabled

Bit 3: BERT Receive All-Ones Condition (BRA1).

0 = interrupt masked
 1 = interrupt enabled—interrupts on rising and falling edges

Bit 2: BERT Receive All-Zeros Condition (BRA0).

0 = interrupt masked
 1 = interrupt enabled—interrupts on rising and falling edges

Bit 1: BERT Receive Loss of Synchronization Condition (BRLOS)

0 = interrupt masked
 1 = interrupt enabled—interrupts on rising and falling edges

Bit 0: BERT in Synchronization Condition (BSYNC).

0 = interrupt masked
 1 = interrupt enabled—interrupts on rising and falling edges

10. FUNCTIONAL TIMING

10.1 T1 Receiver Functional Timing Diagrams

Figure 10-1. T1 Receive-Side D4 Timing

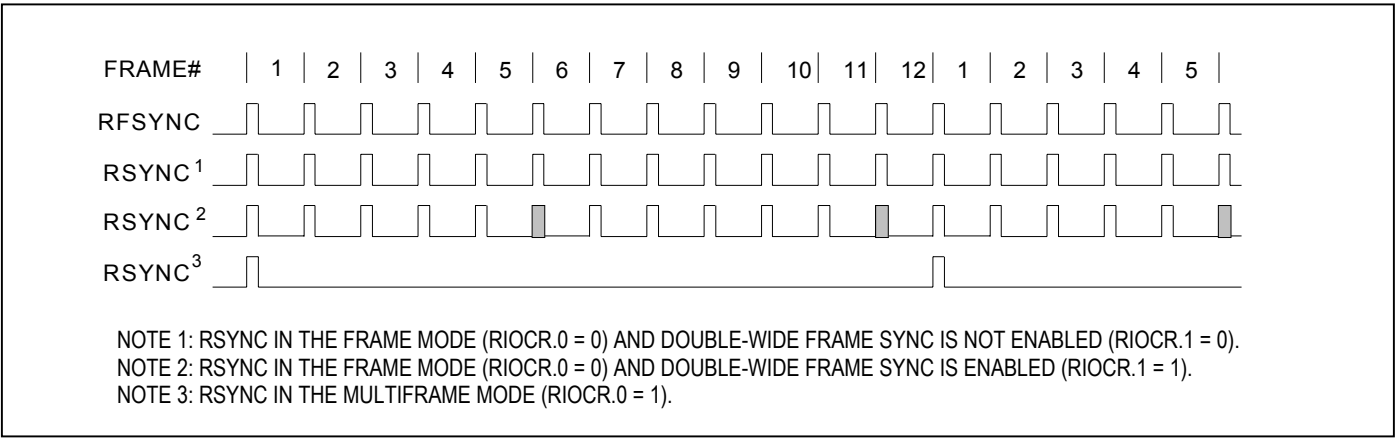


Figure 10-2. T1 Receive-Side ESF Timing

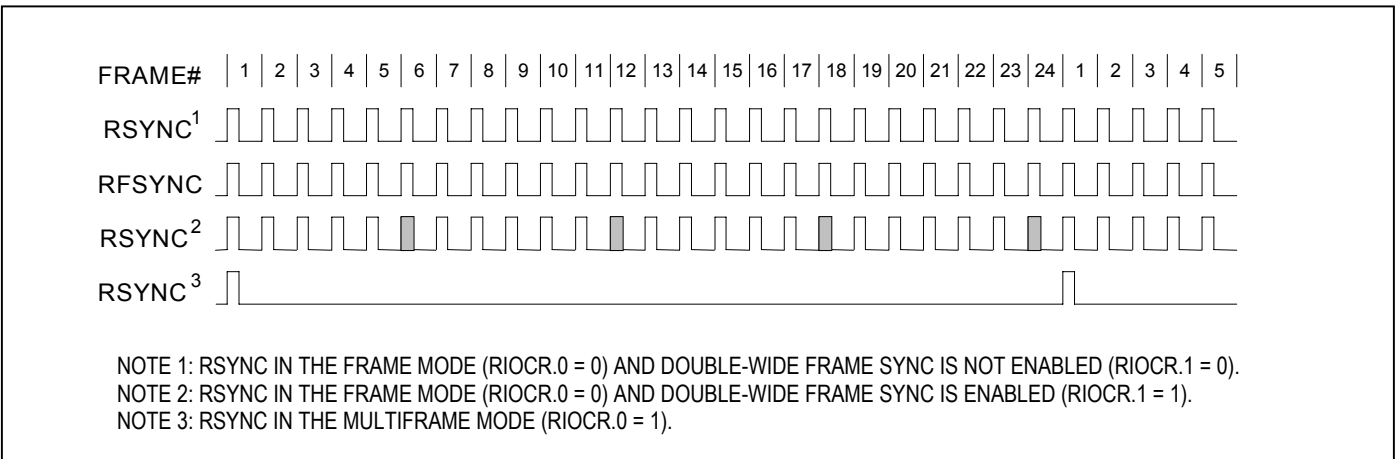


Figure 10-3. T1 Receive-Side Boundary Timing (Elastic Store Disabled)

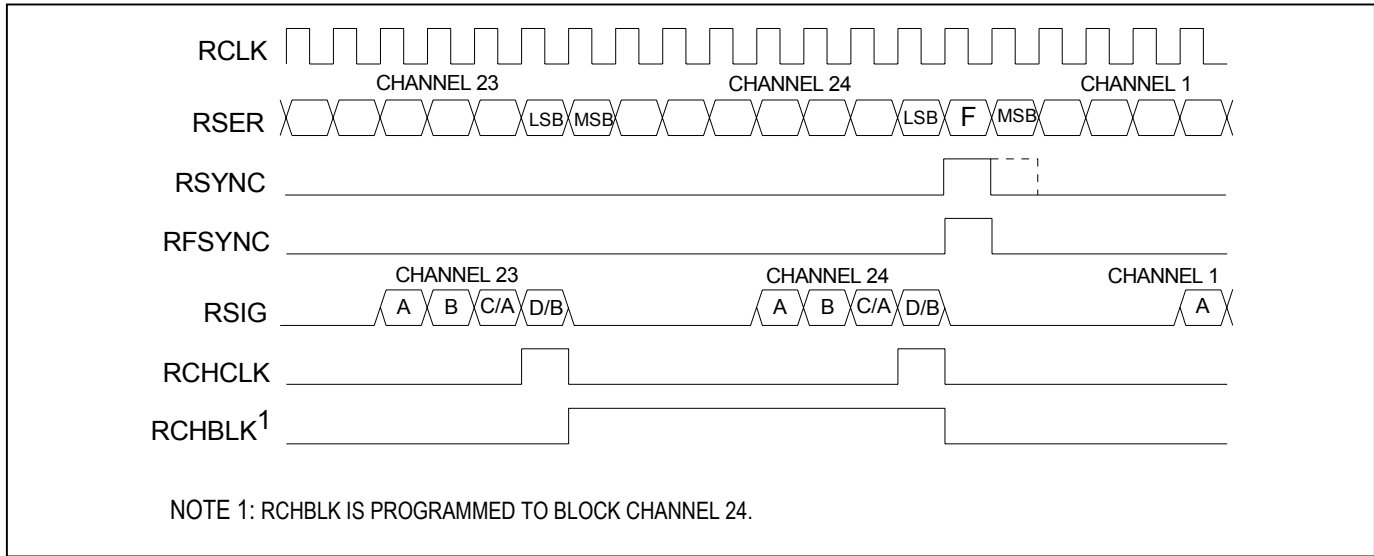


Figure 10-4. T1 Receive-Side 1.544MHz Boundary Timing (Elastic Store Enabled)

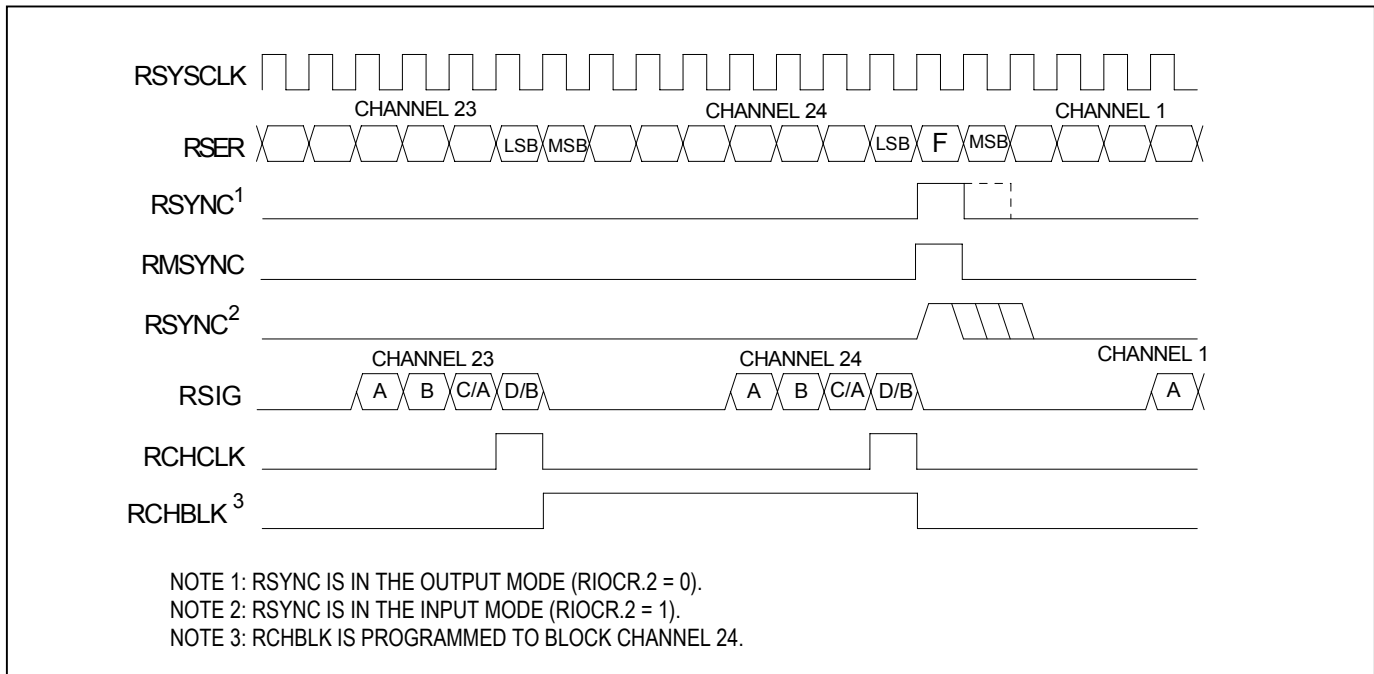
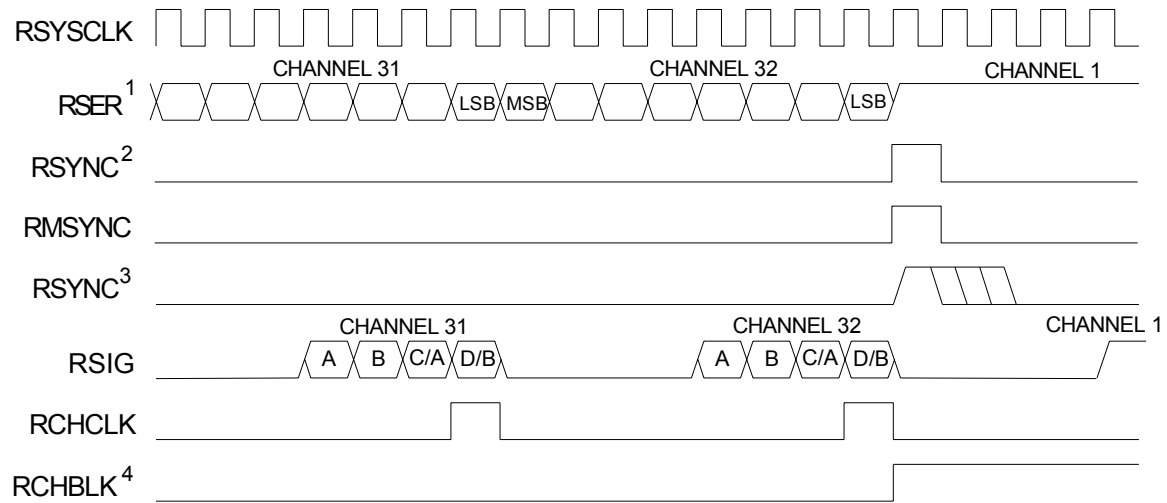


Figure 10-5. T1 Receive-Side 2.048MHz Boundary Timing (Elastic Store Enabled)

NOTE 1: RSER DATA IN CHANNELS 1, 5, 9, 13, 17, 21, 25, AND 29 ARE FORCED TO ONE.

NOTE 2: RSYNC IS IN THE OUTPUT MODE (RIOCR.2 = 0).

NOTE 3: RSYNC IS IN THE INPUT MODE (RIOCR.2 = 1).

NOTE 4: RCHBLK IS PROGRAMMED TO BLOCK CHANNEL 1.

NOTE 5: THE F-BIT POSITION IS PASSED THROUGH THE RECEIVE-SIDE ELASTIC STORE.

Figure 10-6. T1 Receive-Side Interleave Bus Operation—BYTE Mode

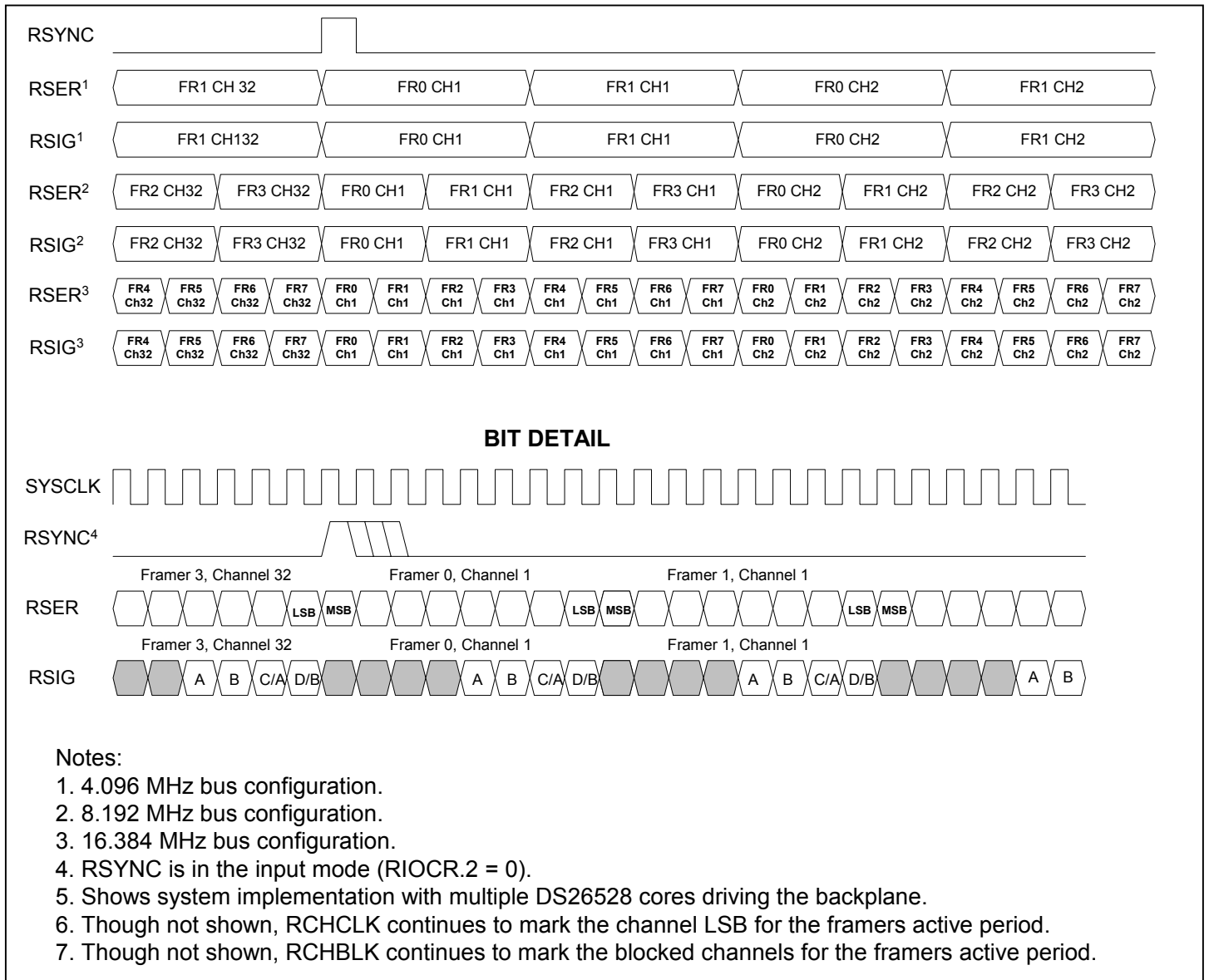
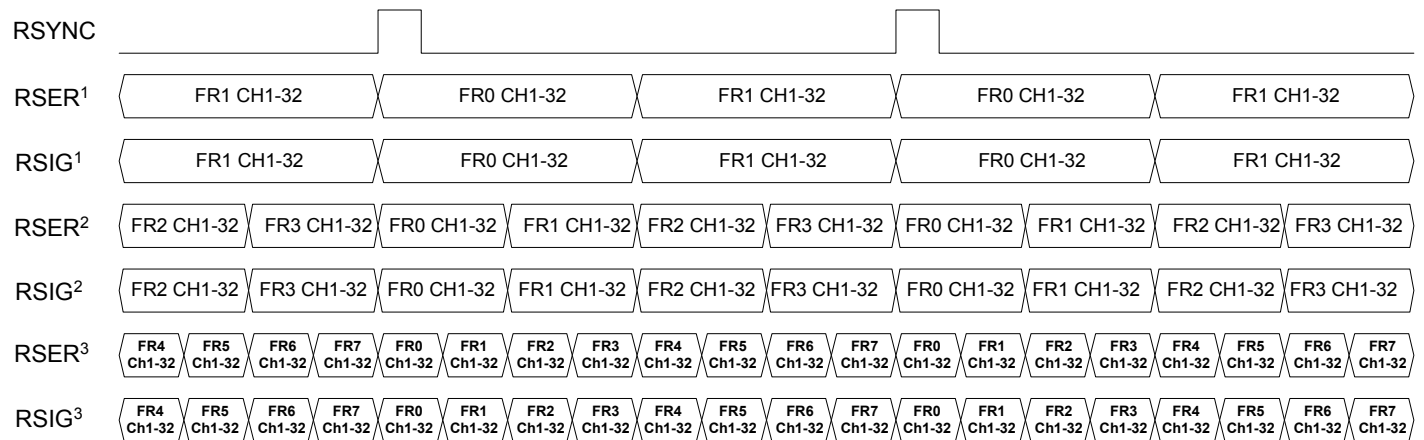
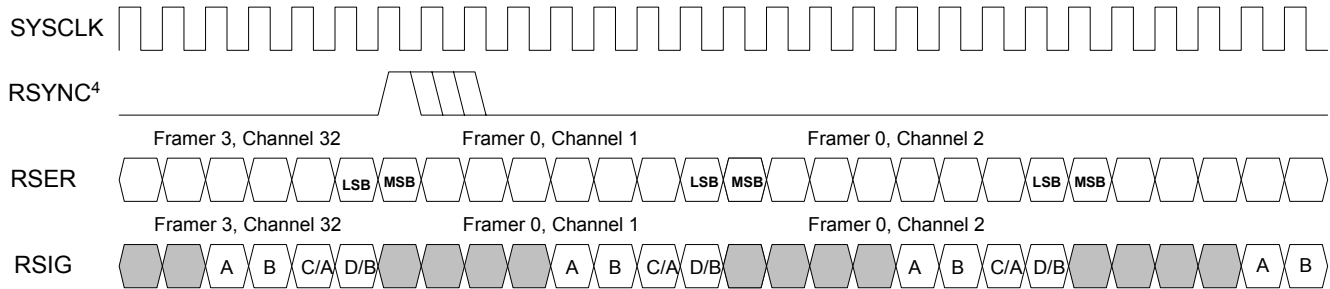


Figure 10-7. T1 Receive-Side Interleave Bus Operation—FRAME Mode



BIT DETAIL



Notes:

1. 4.096 MHz bus configuration.
2. 8.192 MHz bus configuration.
3. 16.384 MHz bus configuration.
4. RSYNC is in the input mode (RIOCR.2 = 0).
5. Shows system implementation with multiple DS26528 cores driving the backplane.
6. Though not shown, RCHCLK continues to mark the channel LSB for the framers active period.
7. Though not shown, RCHBLK continues to mark the blocked channels for the framers active period.

10.2 T1 Transmitter Functional Timing Diagrams

Figure 10-8. T1 Transmit-Side D4 Timing

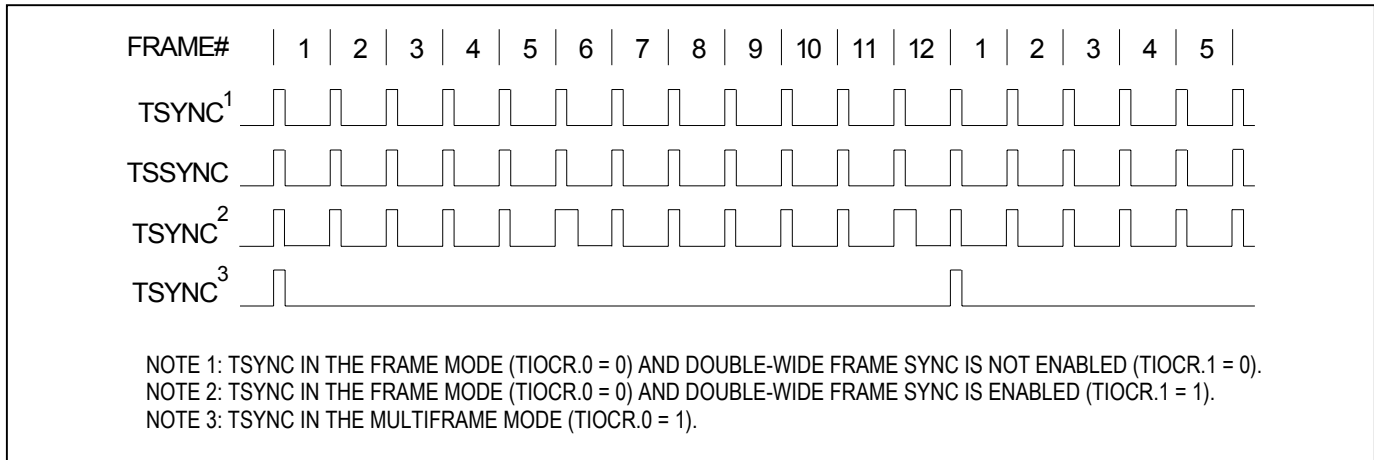


Figure 10-9. T1 Transmit-Side ESF Timing

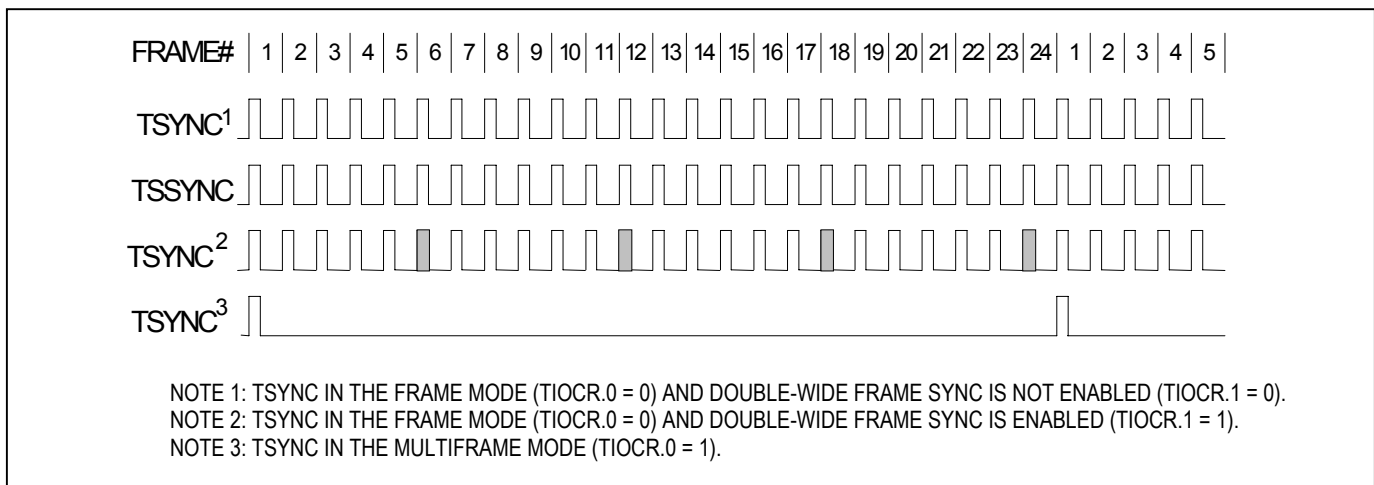


Figure 10-10. T1 Transmit-Side Boundary Timing (Elastic Store Disabled)

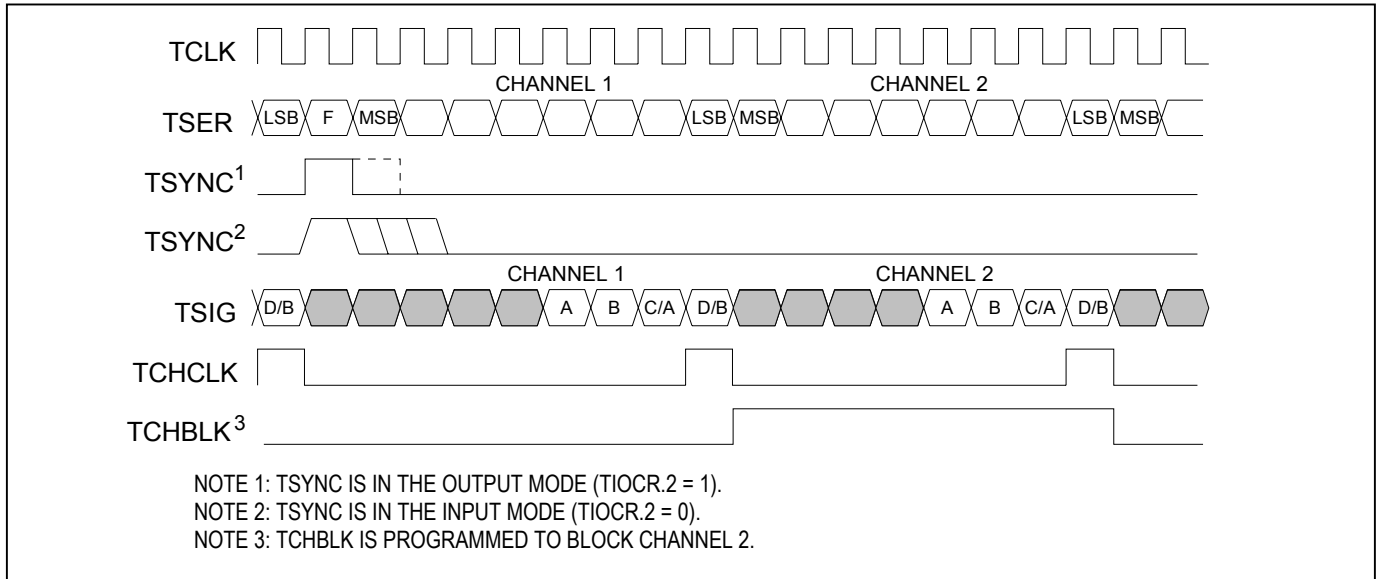


Figure 10-11. T1 Transmit-Side 1.544MHz Boundary Timing (Elastic Store Enabled)

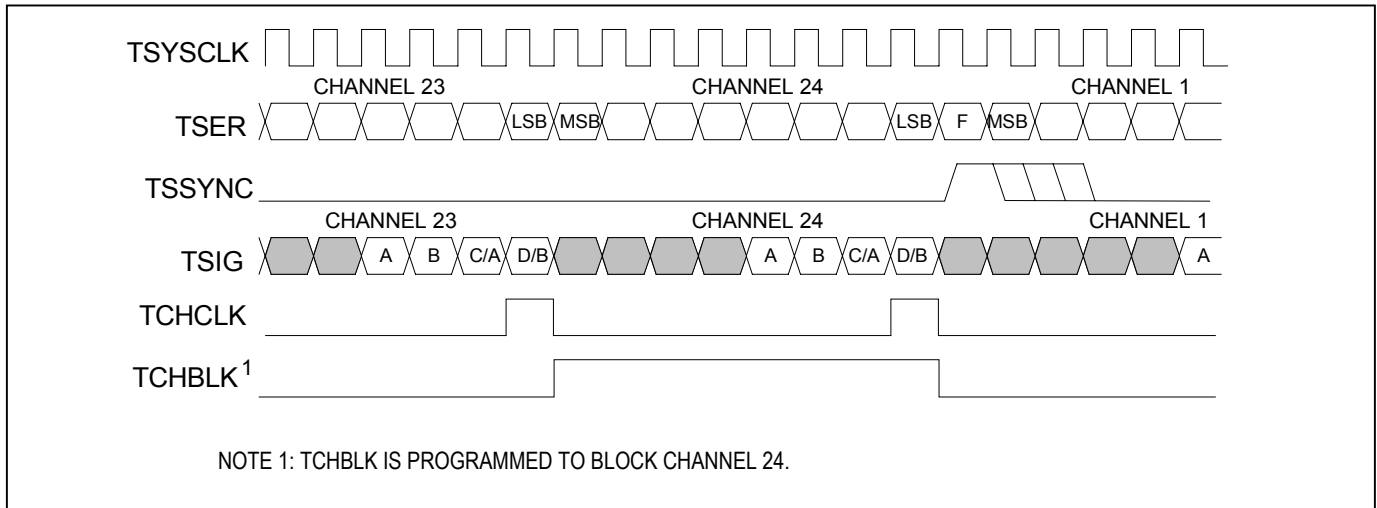


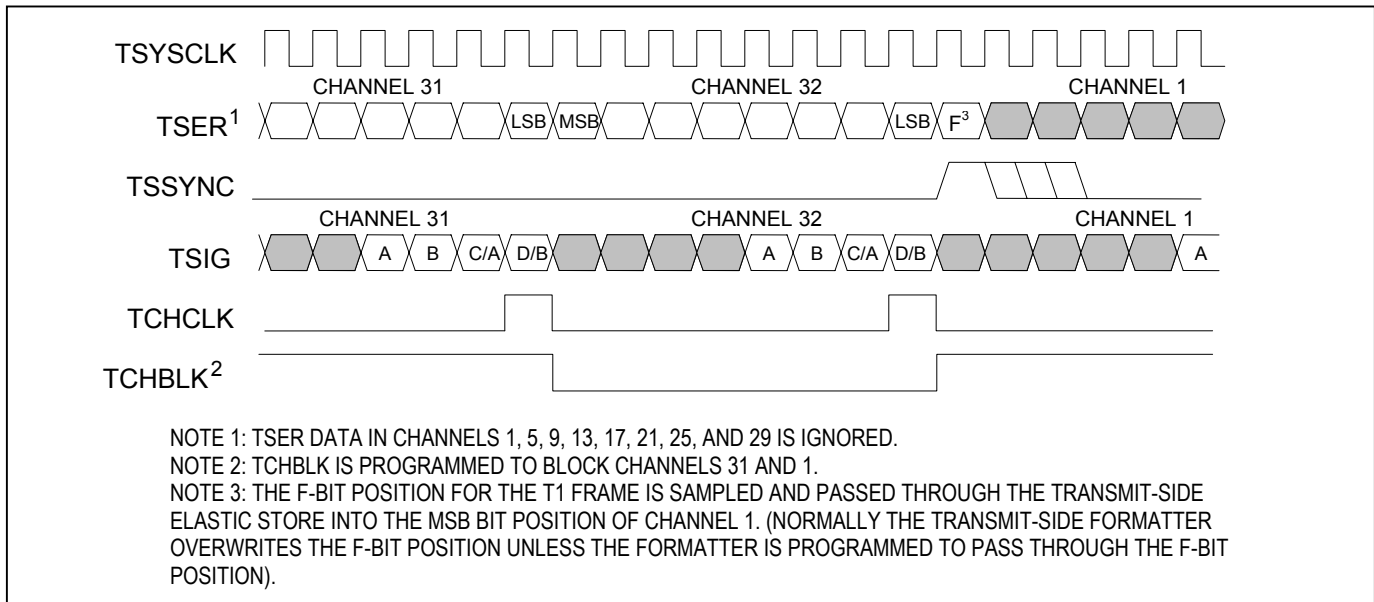
Figure 10-12. T1 Transmit-Side 2.048MHz Boundary Timing (Elastic Store Enabled)

Figure 10-13. T1 Transmit-Side Interleave Bus Operation—BYTE Mode

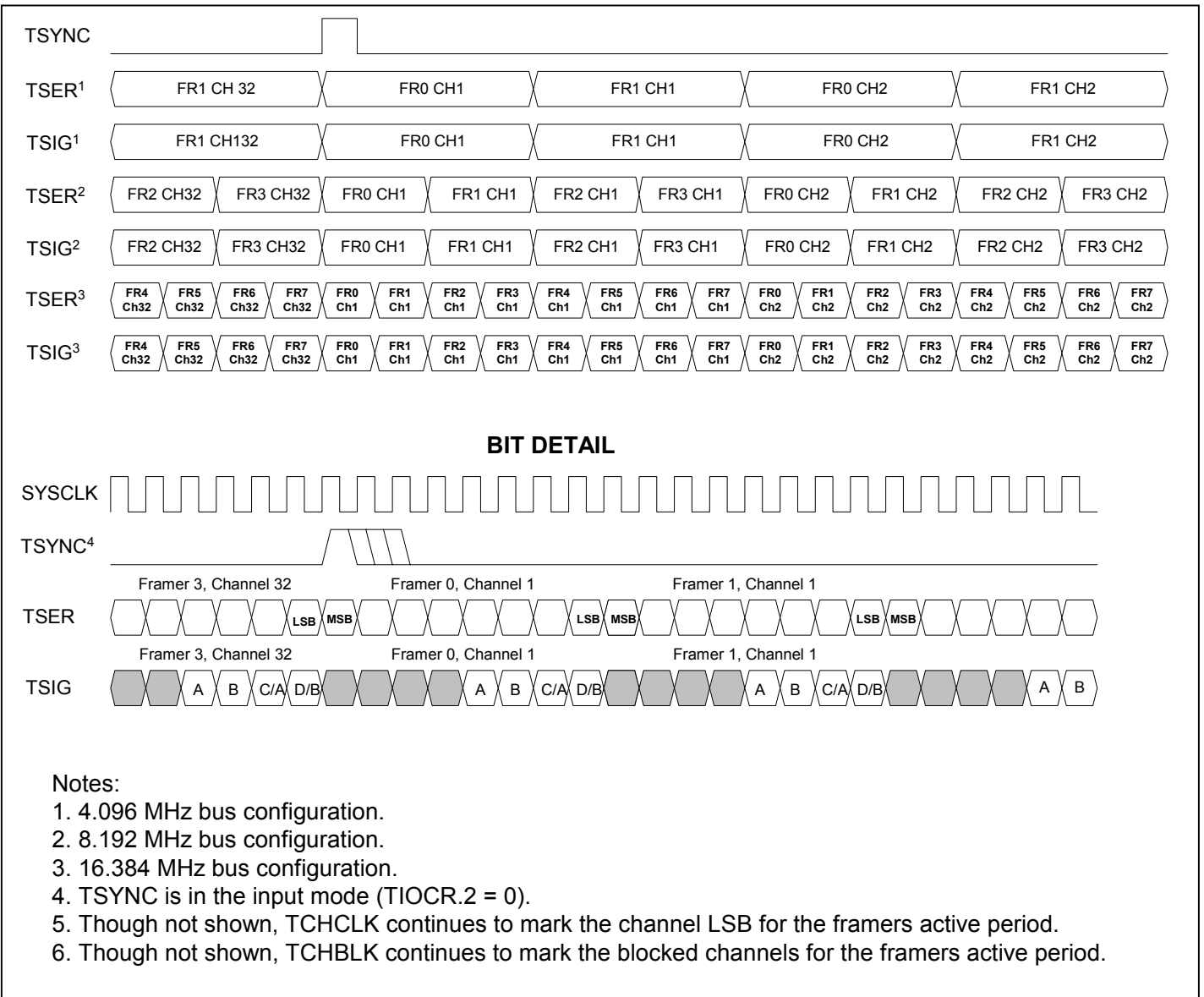
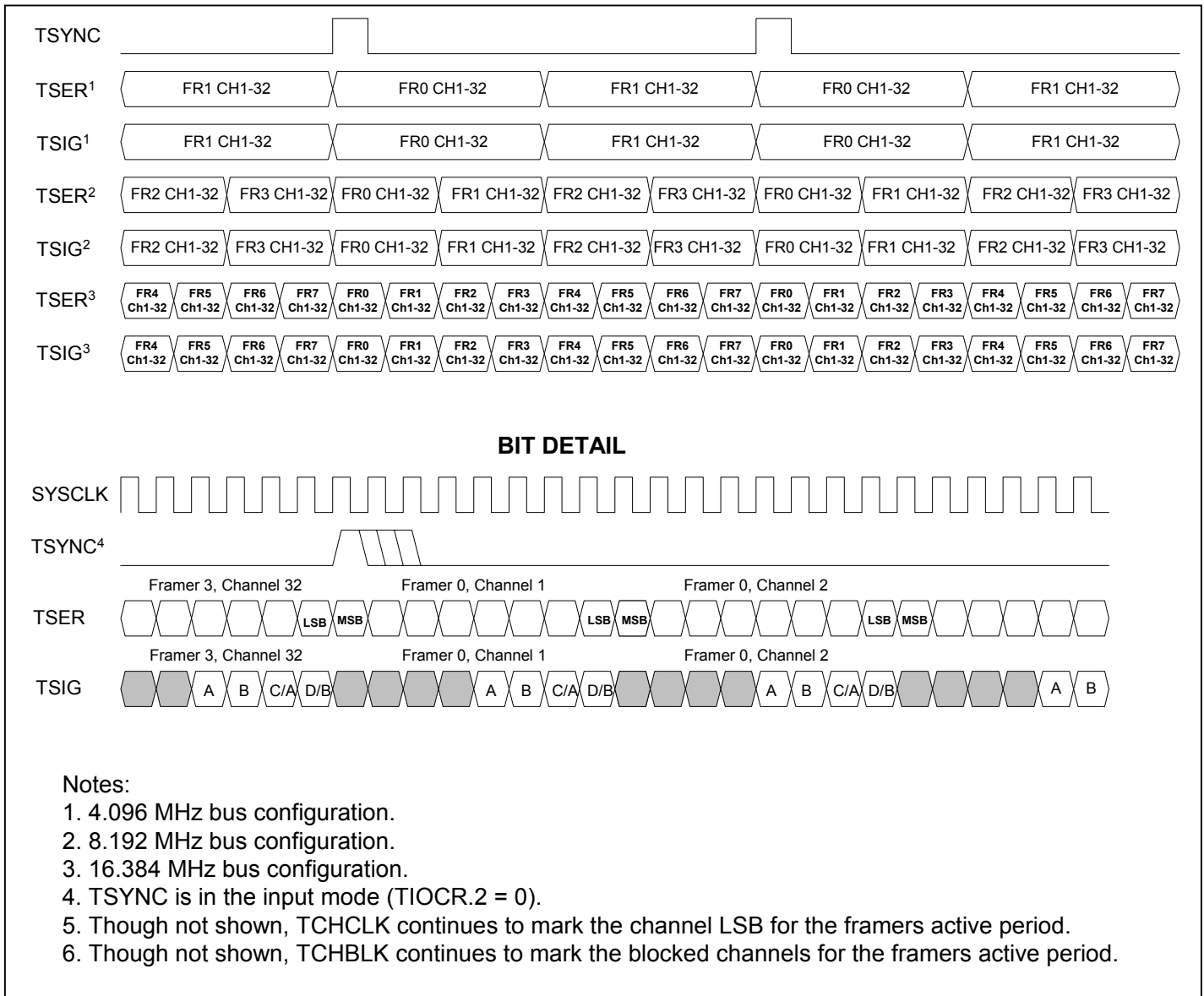


Figure 10-14. T1 Transmit Interleave Bus Operation—FRAME Mode



10.3 E1 Receiver Functional Timing Diagrams

Figure 10-15. E1 Receive-Side Timing

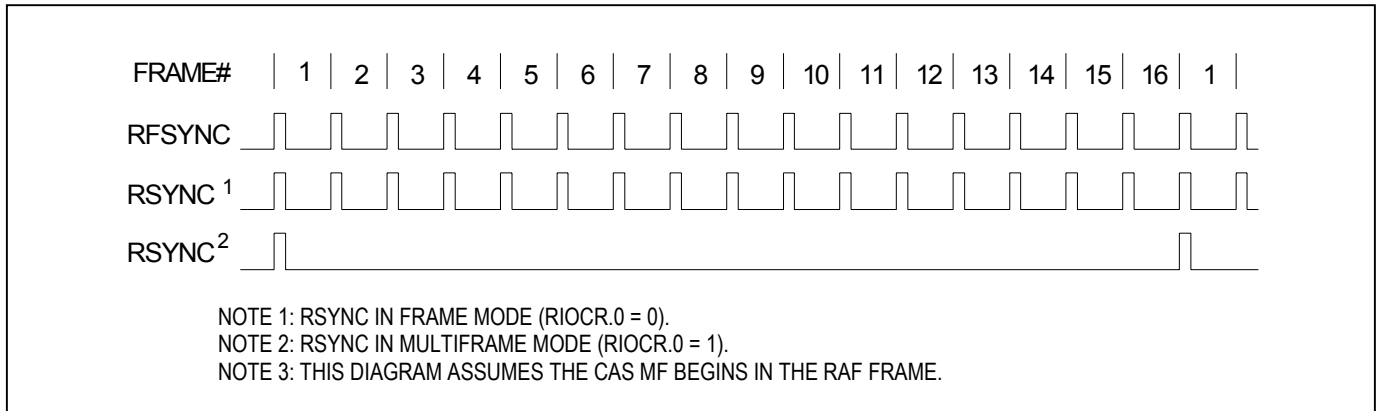


Figure 10-16. E1 Receive-Side Boundary Timing (Elastic Store Disabled)

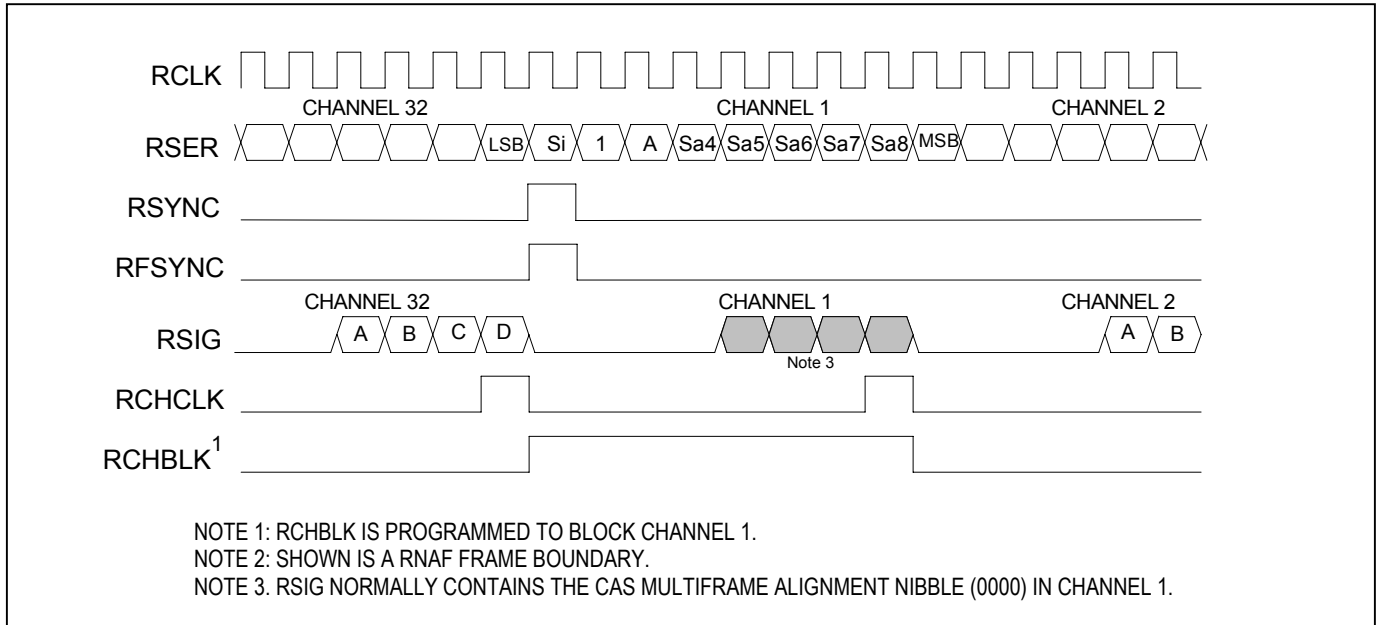


Figure 10-17. E1 Receive-Side 1.544MHz Boundary Timing (Elastic Store Enabled)

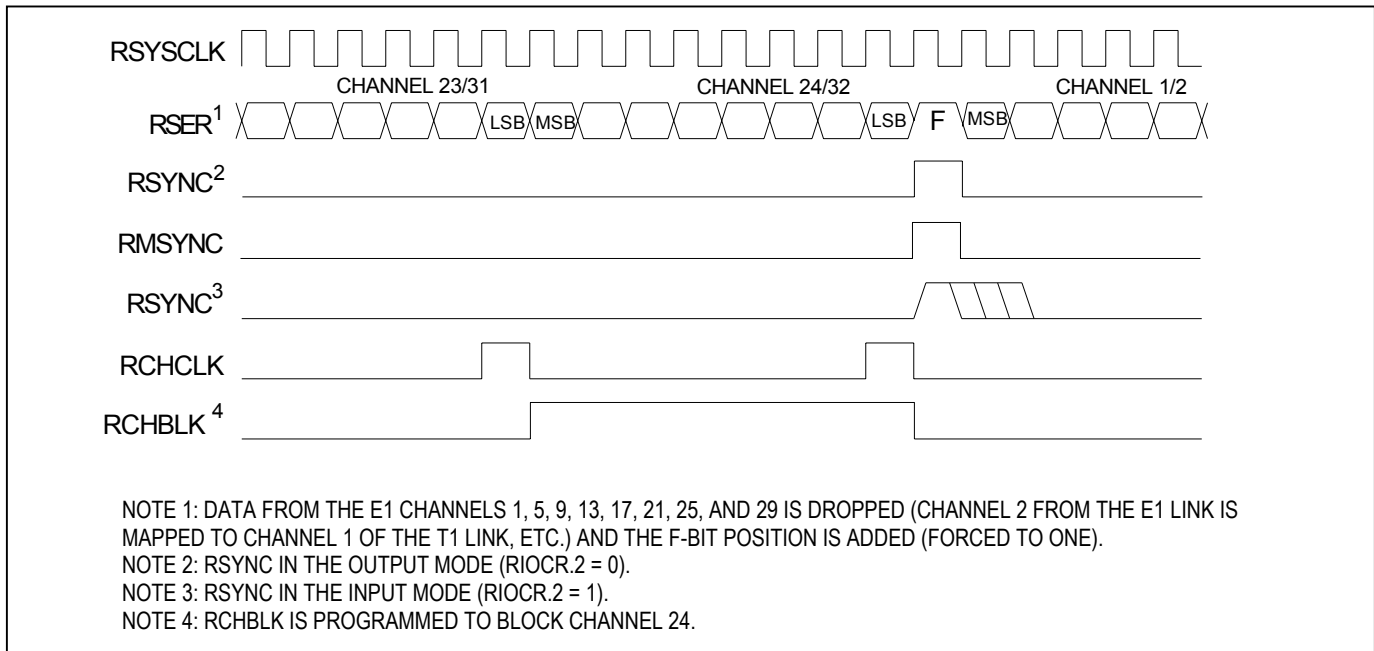
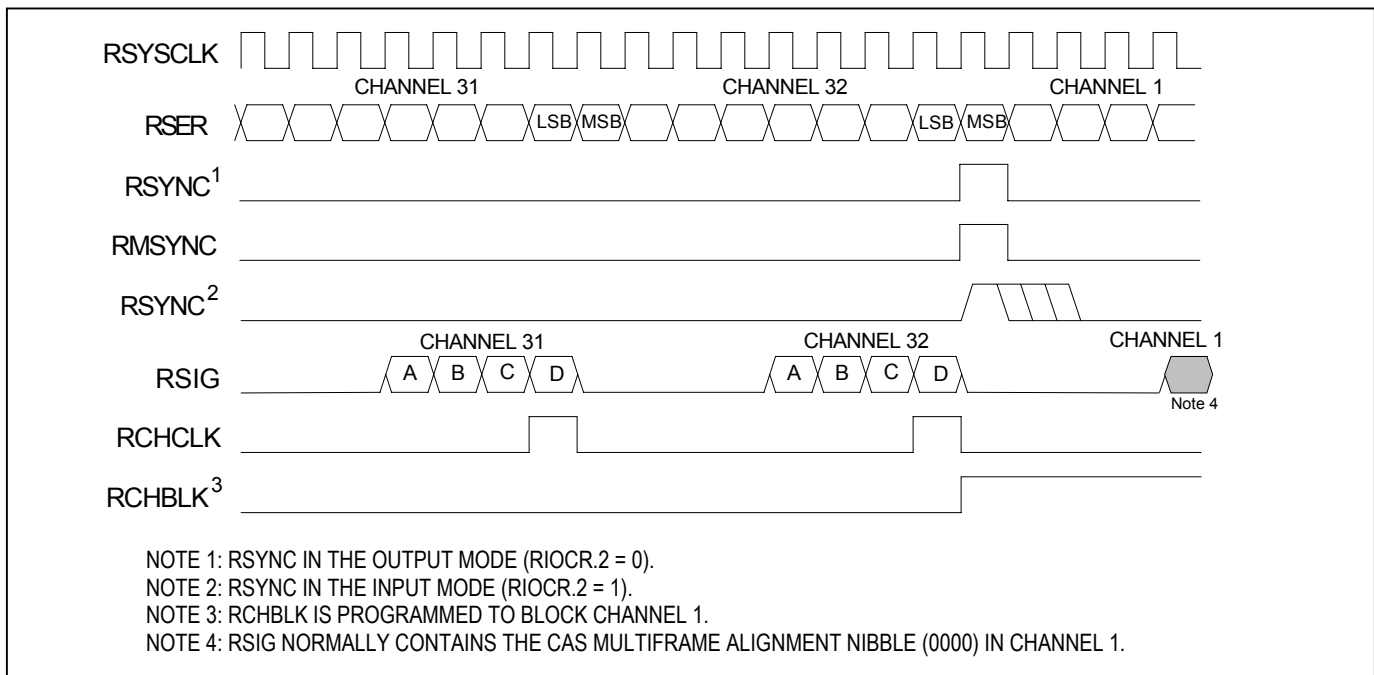


Figure 10-18. E1 Receive-Side 2.048MHz Boundary Timing (Elastic Store Enabled)



10.4 E1 Transmitter Functional Timing Diagrams

Figure 10-19. E1 Transmit-Side Timing

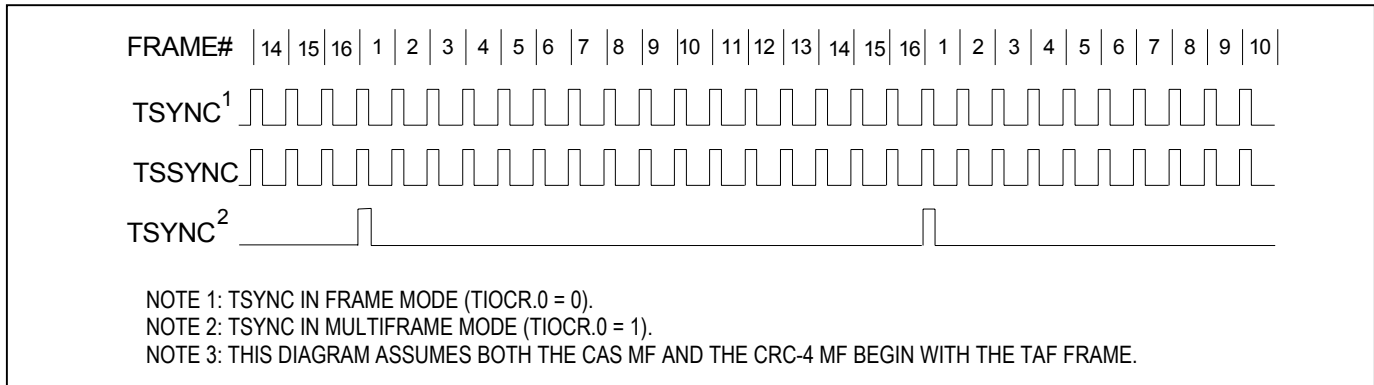


Figure 10-20. E1 Transmit-Side Boundary Timing (Elastic Store Disabled)

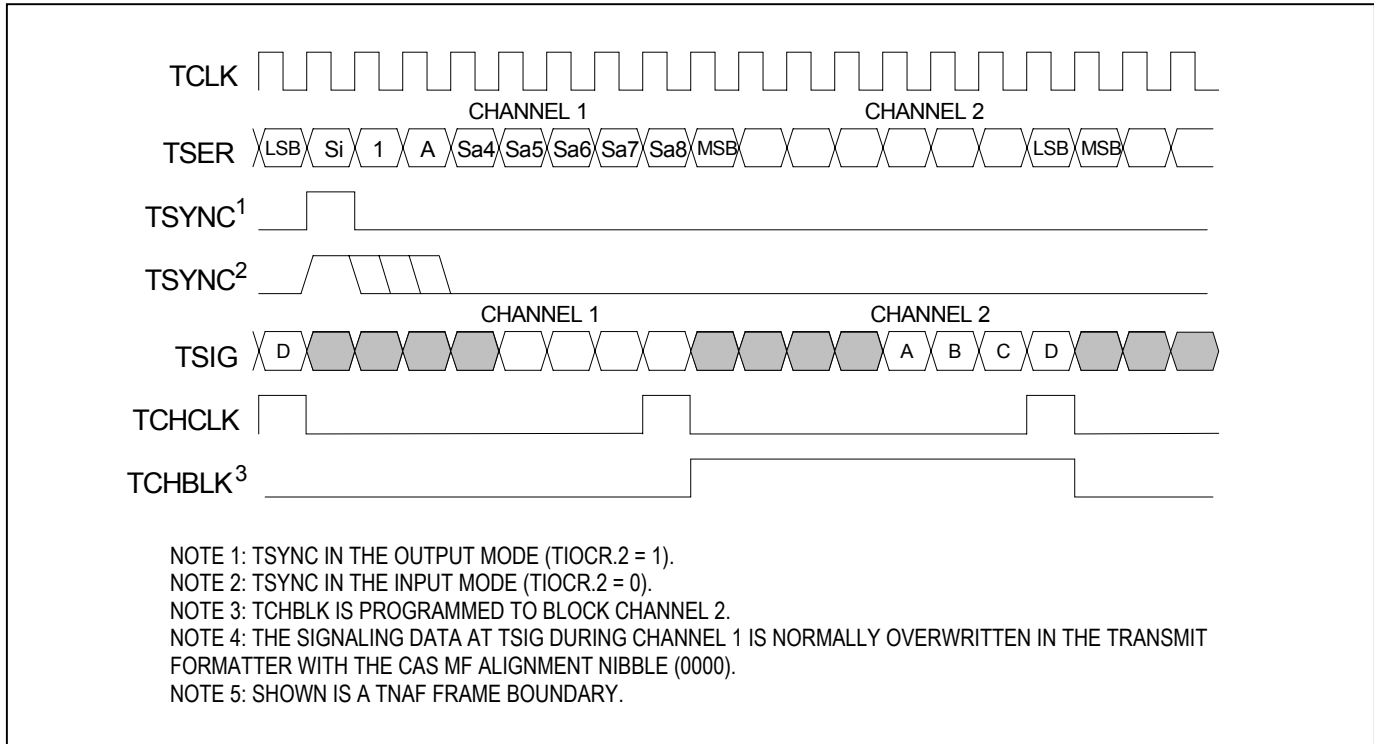


Figure 10-21. E1 Transmit-Side 1.544MHz Boundary Timing (Elastic Store Enabled)

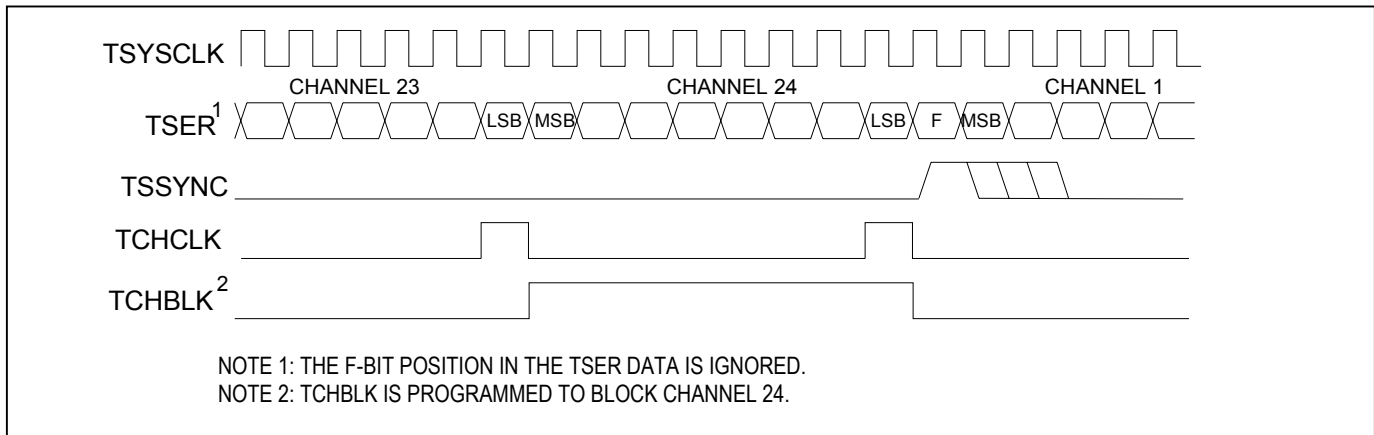


Figure 10-22. E1 Transmit-Side 2.048MHz Boundary Timing (Elastic Store Enabled)

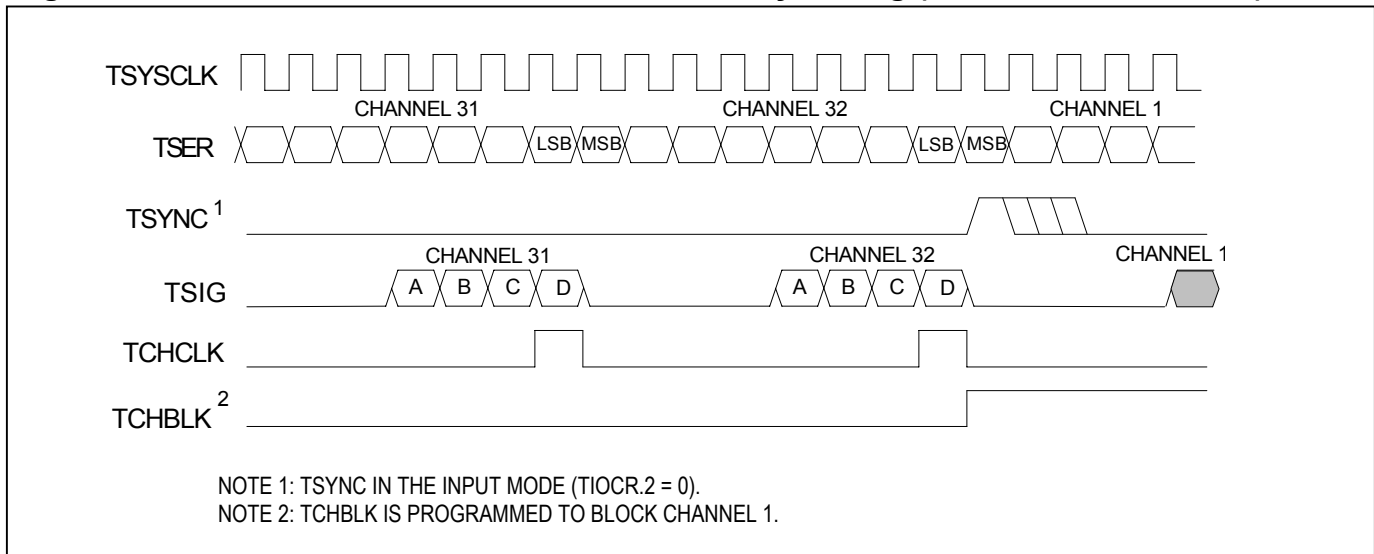
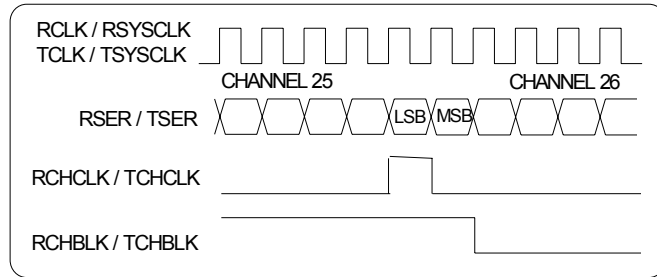
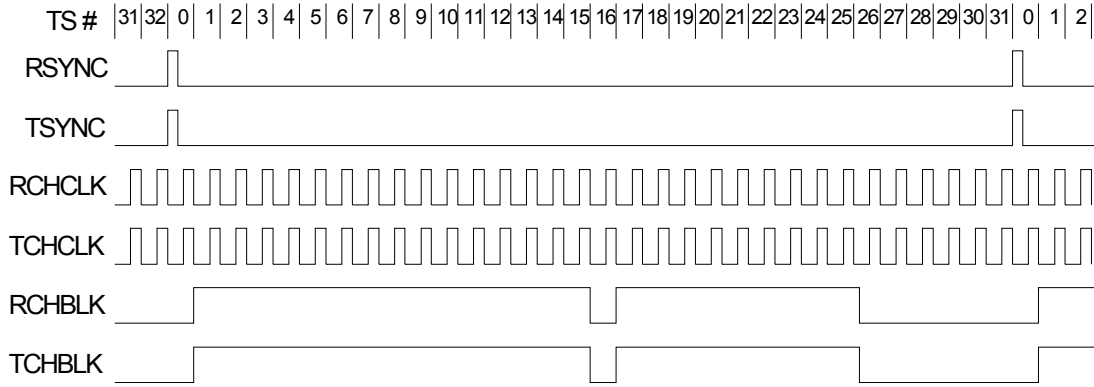


Figure 10-23. E1 G.802 Timing



NOTE: RCHBLK OR TCHBLK PROGRAMMED TO PULSE HIGH DURING TIME SLOTS 1 THROUGH 15, 17 THROUGH 25, AND BIT 1 OF TIME SLOT 26.

11. OPERATING PARAMETERS

ABSOLUTE MAXIMUM RATINGS

Voltage Range on Any Lead with Respect to V_{SS} (except V_{DD}).....	-0.3V to +5.5V
Supply Voltage (V_{DD}) Range with Respect to V_{SS}	-0.3V to +3.63V
Operating Temperature Range	
Commercial (DS26524G).....	0°C to +70°C
Industrial (DS26524GN).....	-40°C to +85°C (Note 1)
Storage Temperature Range.....	-55°C to +125°C
Soldering Temperature.....	See IPC/JEDEC J-STD-020 Specification

This is a stress rating only and functional operation of the device at these or any other conditions above those indicated in the operation sections of this specification is not implied. Exposure to absolute maximum rating conditions for extended periods of time may affect reliability.

Note 1: Specifications to -40°C are guaranteed by design and not production tested.

Table 11-1. Recommended DC Operating Conditions

($T_A = -40^\circ\text{C}$ to $+85^\circ\text{C}$ for DS26524GN.)

PARAMETER	SYMBOL	CONDITIONS	MIN	TYP	MAX	UNITS
Logic 1	V_{IH}		2.0		5.5	V
Logic 0	V_{IL}		-0.3		+0.8	V
Supply	V_{DD}		3.135	3.3	3.465	V

Table 11-2. Capacitance

($T_A = +25^\circ\text{C}$)

PARAMETER	SYMBOL	CONDITIONS	MIN	TYP	MAX	UNITS
Input Capacitance	C_{IN}			7		pF
Output Capacitance	C_{OUT}			7		pF

Table 11-3. Recommended DC Operating Conditions

($V_{DD} = 3.135\text{V}$ to 3.465V , $T_A = -40^\circ\text{C}$ to $+85^\circ\text{C}$ for DS26524GN.)

PARAMETER	SYMBOL	CONDITIONS	MIN	TYP	MAX	UNITS
Supply Current at 3.3V	I_{DD}	(Notes 2, 3)		260	450	mA
Input Leakage	I_{IL}		-10.0		+10.0	μA
Pullup Pin Input Leakage	I_{ILP}	(Note 4)	-500.0		+10.0	μA
Tri-State Output Leakage	I_{OL}		-10.0		+10.0	μA
Output Voltage ($I_o = -1.6\text{mA}$)	V_{OH}		2.4			V
Output Voltage ($I_o = +0.4\text{mA}$)	V_{OL}				0.4	V

Note 2: $RCLK1-n = TCLK1-n = 2.048\text{MHz}$.

Note 3: Max power dissipation is measured with both ports transmitting an all-ones data pattern with a transmitter load of 100Ω .

Note 4: Pullup pins include DIGIOEN, \overline{JTRST} , JTMS, and JTDI.

11.1 Thermal Characteristics

Table 11-4. Thermal Characteristics

PARAMETER	CONDITIONS	MIN	TYP	MAX	UNITS
Ambient Temperature (Note 1)	DS26524G	0		+70	°C
	DS26524GN	-40		+85	
Junction Temperature				+125	°C
Theta-JA (θ_{JA}) in Still Air for 256-Pin TE-CSBGA	(Note 2)		+17.5		°C/W

Note 1: The package is mounted on a four-layer JEDEC standard test board.

Note 2: Theta-JA (θ_{JA}) is the junction-to-ambient thermal resistance, when the package is mounted on a four-layer JEDEC standard test board.

11.2 Line Interface Characteristics

Table 11-5. Transmitter Characteristics

PARAMETER	SYMBOL	CONDITIONS	MIN	TYP	MAX	UNITS
Output Mark Amplitude	V_m	E1 75 Ω	2.13	2.37	2.61	V
		E1 120 Ω	2.70	3.00	3.30	
		T1 100 Ω	2.40	3.00	3.60	
		J1 110 Ω	2.40	3.00	3.60	
Output Zero Amplitude	V_s	(Note 1)	-0.3		+0.3	V
Transmit Amplitude Variation with Supply			-1		+1	%

Table 11-6. Receiver Characteristics

PARAMETER	SYMBOL	CONDITIONS	MIN	TYP	MAX	UNITS
Cable Attenuation	Attn				43	dB
Allowable Zeros Before Loss (Note 1)				192		
				192		
				2048		
Allowable Ones Before Loss (Note 2)				24		
				192		
				192		

Note 1: 192 zeros for T1 and T1.231 Specification Compliance. 192 zeros for E1 and G.775 Specification Compliance. 2048 zeros for ETS 300 233 compliance.

Note 2: 24 ones in 192-bit period for T1.231; 192 ones for G.775; 192 ones for ETS 300 233.

12. AC TIMING CHARACTERISTICS

Unless otherwise noted, all timing numbers assume 20pF test load on output signals, 40pF test load on bus signals.

12.1 Microprocessor Bus AC Characteristics

Table 12-1. AC Characteristics—Microprocessor Bus Timing

($V_{DD} = 3.3V \pm 5\%$, $T_A = -40^\circ C$ to $+85^\circ C$ for DS26524GN.) (Note 1) (See [Figure 12-1](#), [Figure 12-2](#), [Figure 12-3](#), and [Figure 12-4](#).)

PARAMETER	SYMBOL	CONDITIONS	MIN	TYP	MAX	UNITS
Setup Time for A[12:0] Valid to \overline{CSB} Active	t1		0			ns
Setup Time for \overline{CSB} Active to Either \overline{RDB} , or \overline{WRB} Active	t2		0			ns
Delay Time from Either \overline{RDB} or \overline{DSB} Active to D[7:0] Valid	t3	(Note 2)			125	ns
Hold Time from Either \overline{RDB} or \overline{WRB} Inactive to \overline{CSB} Inactive	t4		0			ns
Hold Time from \overline{CSB} or \overline{RDB} or \overline{DSB} Inactive to D[7:0] Tri-State	t5		5		20	ns
Wait Time from \overline{WRB} Active to Latch Data	t6		40			ns
Data Setup Time to \overline{WRB} Inactive	t7		10			ns
Data Hold Time from \overline{WRB} Inactive	t8		2			ns
Address Hold from \overline{WRB} Inactive	t9		0			ns
Write Access to Subsequent Write/Read Access Delay Time	t10	(Note 2)	80			ns

Note 1: The timing parameters in this table are guaranteed by design (GBD).

Note 2: If supplying a 1.544MHz MCLK, the FREQSEL bit must be set to meet this timing.

Figure 12-1. Intel Bus Read Timing (BTS = 0)

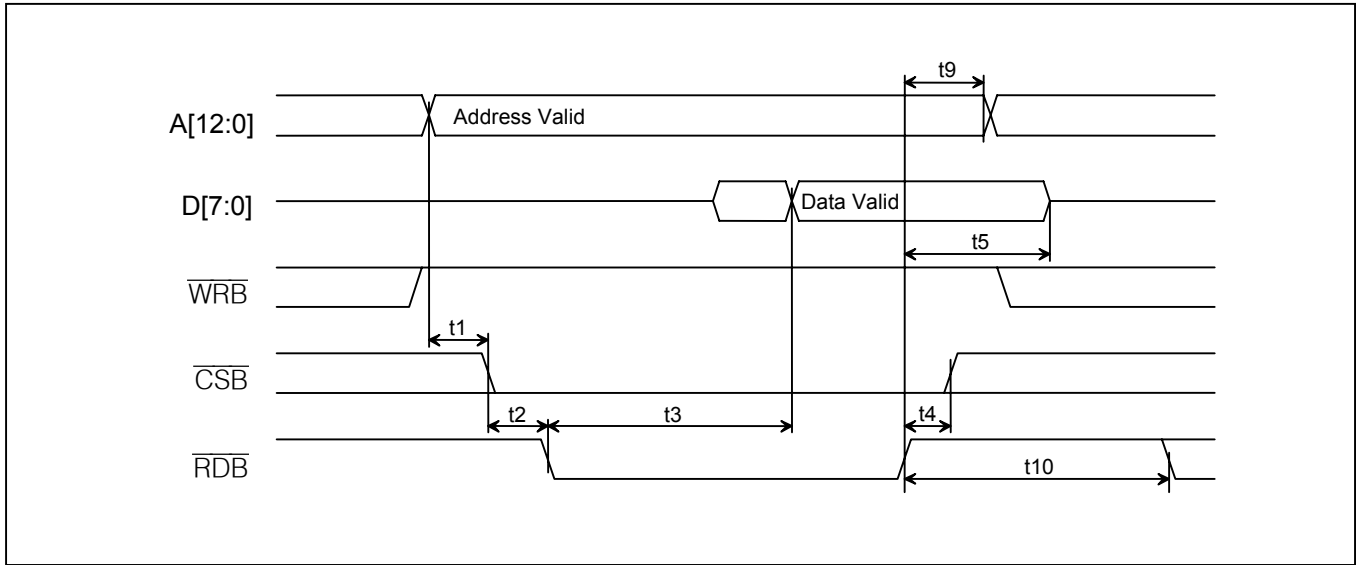


Figure 12-2. Intel Bus Write Timing (BTS = 0)

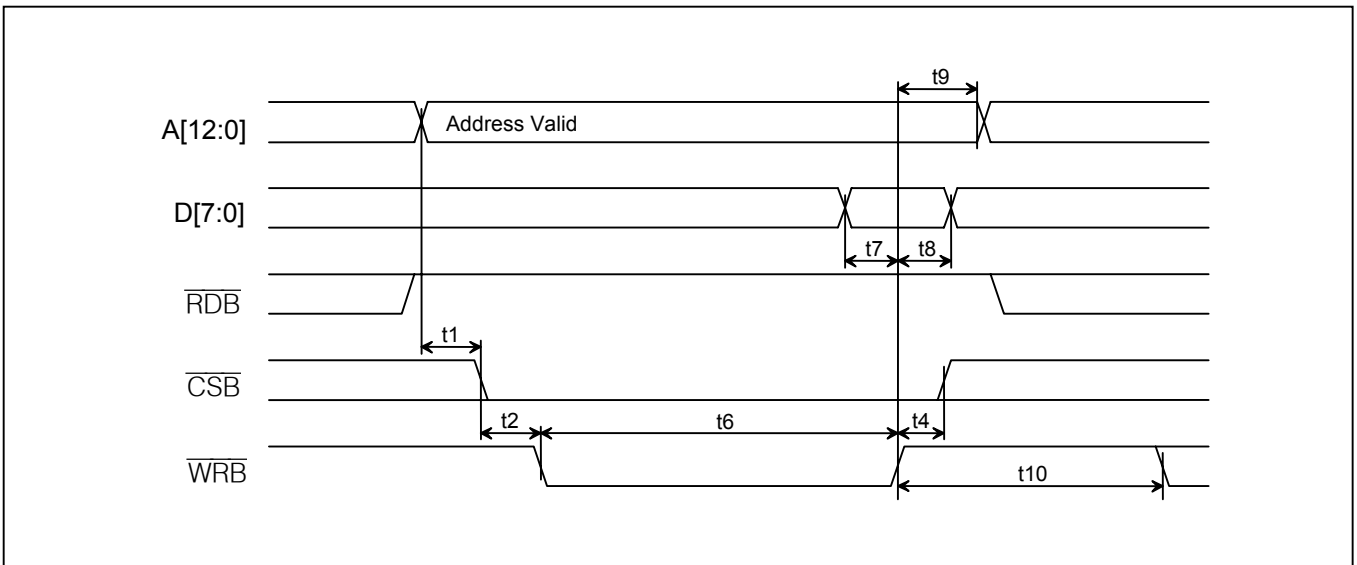


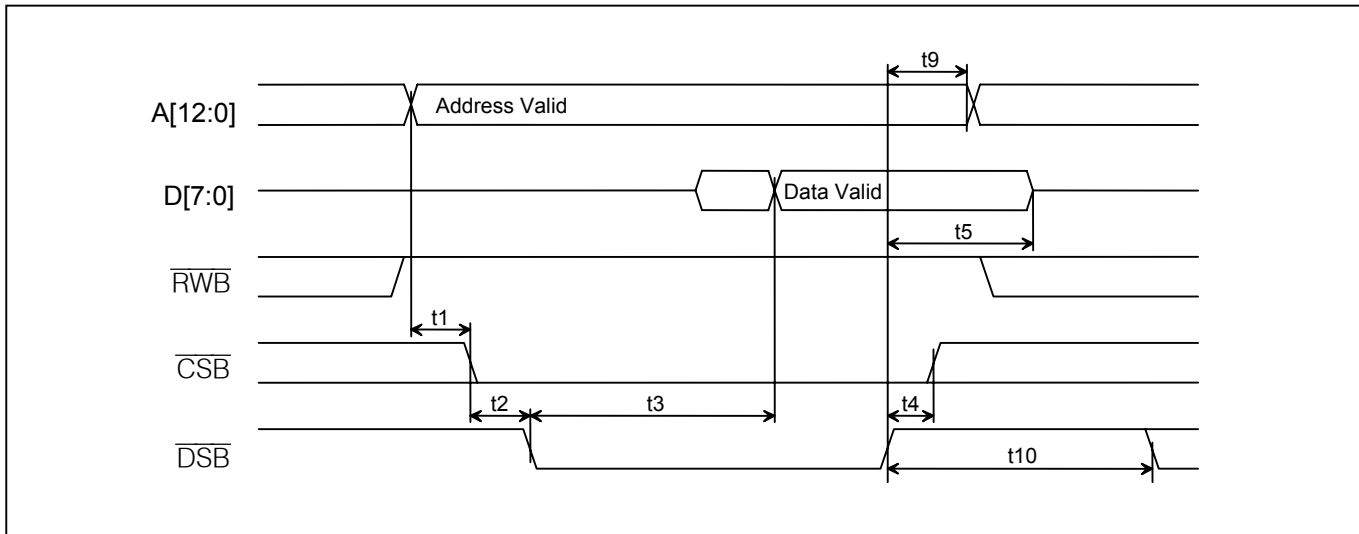
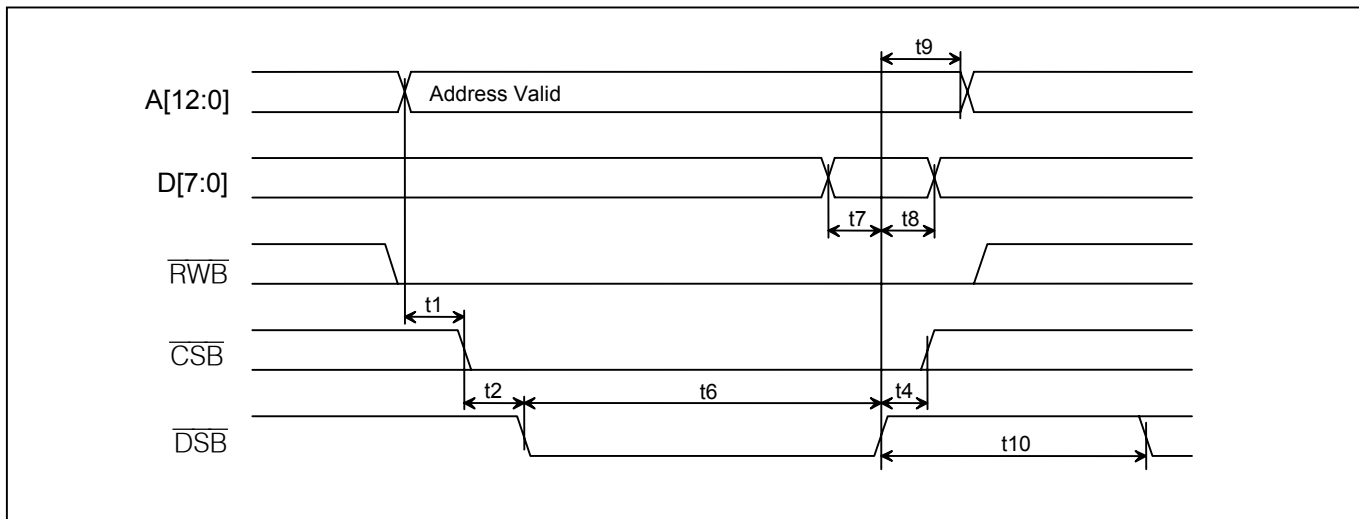
Figure 12-3. Motorola Bus Read Timing (BTS = 1)**Figure 12-4. Motorola Bus Write Timing (BTS = 1)**

Table 12-2. Receiver AC Characteristics

($V_{DD} = 3.3V \pm 5\%$, $T_A = -40^\circ C$ to $+85^\circ C$ for DS26524GN.) (Note 1) (See [Figure 12-5](#), [Figure 12-6](#), and [Figure 12-7](#).)

PARAMETER	SYMBOL	CONDITIONS	MIN	TYP	MAX	UNITS
RCLK Period	t_{CP}	(Note 2)		648		ns
		(Note 3)		488		
RCLK Pulse Width	t_{CH}		125			ns
	t_{CL}		125			
RSYSCLK Period	t_{SP}	(Note 4)	60	648		ns
		(Note 5)	60	488		
RSYSCLK Pulse Width	t_{SH}		30			ns
	t_{SL}		30			
RSYNC Setup to RSYSCLK Falling	t_{SU}		20		$t_{SH} - 5$	ns
RSYNC Pulse Width	t_{PW}		50			ns
Delay RCLK to RSER, RSIG Valid	t_{D1}				50	ns
Delay RCLK to RCHCLK, RSYNC, RCHBLK, RFSYNC	t_{D2}				50	ns
Delay RSYSCLK to RSER, RSIG Valid	t_{D3}				50	ns
Delay RSYSCLK to RCHCLK, RCHBLK, RMSYNC, RSYNC	t_{D4}				50	ns

Note 1: The timing parameters in this table are guaranteed by design (GBD).

Note 2: T1 Mode.

Note 3: E1 Mode.

Note 4: RSYSCLK = 1.544MHz.

Note 5: RSYSCLK = 2.048MHz.

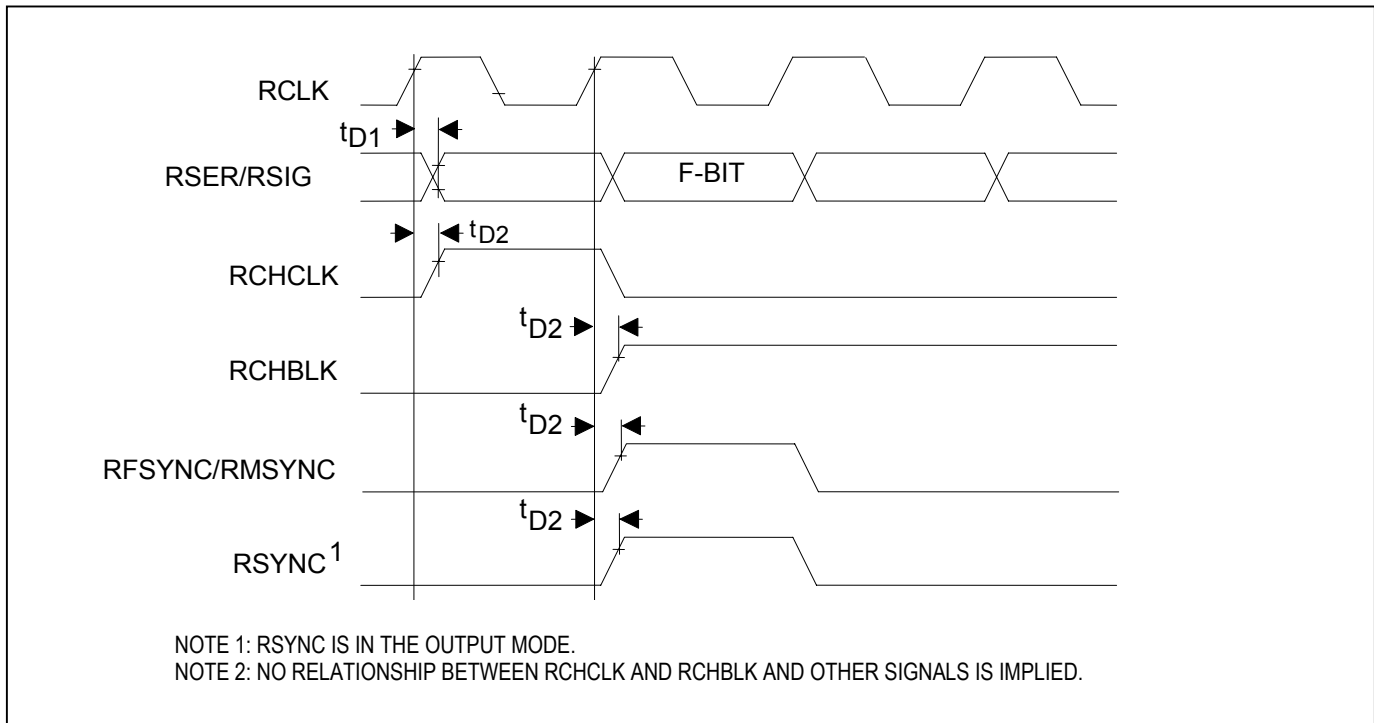
Figure 12-5. Receive Framer Timing—Backplane (T1 Mode)

Figure 12-6. Receive-Side Timing, Elastic Store Enabled (T1 Mode)

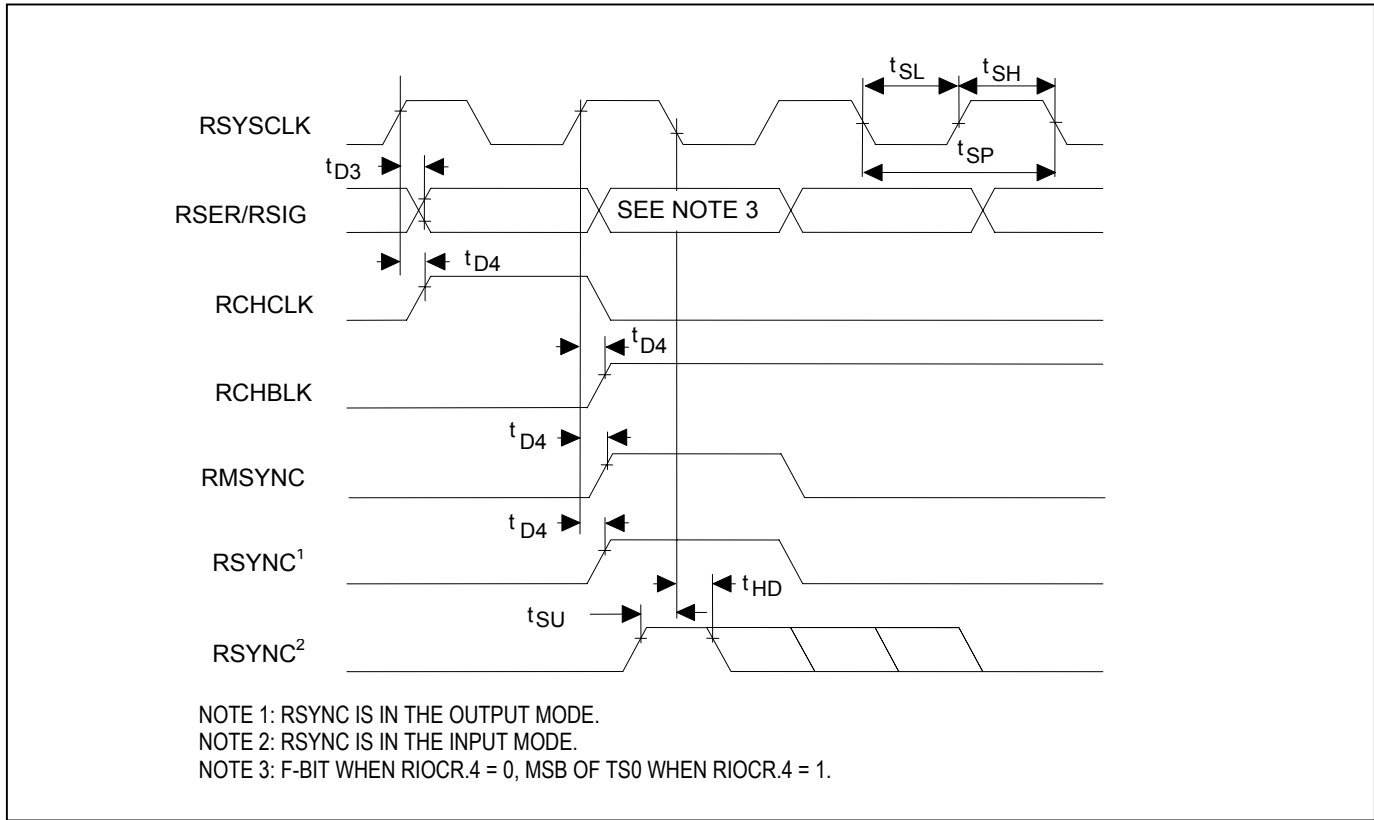


Figure 12-7. Receive Framer Timing—Line Side

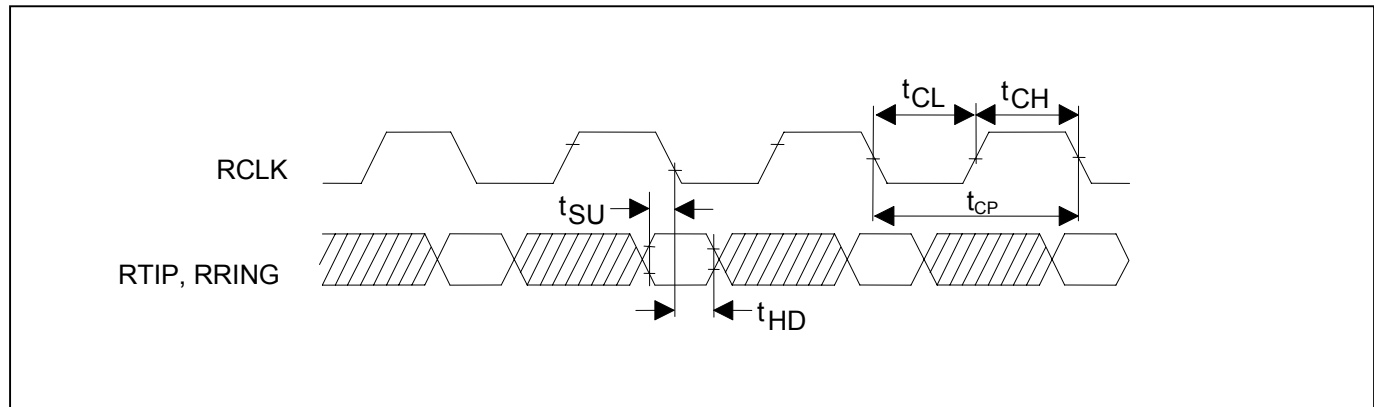


Table 12-3. Transmit AC Characteristics

($V_{DD} = 3.3V \pm 5\%$, $T_A = -40^\circ C$ to $+85^\circ C$ for DS26524GN.) (Note 1) (See [Figure 12-8](#), [Figure 12-9](#), [Figure 12-10](#), and [Figure 12-11](#).)

PARAMETER	SYMBOL	CONDITIONS	MIN	TYP	MAX	UNITS
TCLK Period	t_{CP}	(Note 2)		648		ns
		(Note 3)		488		
TCLK Pulse Width	t_{CH}		125			ns
	t_{CL}		125			
TSYSCLK Period	t_{SP}	(Note 4)	60	648		ns
		(Note 5)	60	448		
TSYSCLK Pulse Width	t_{SH}		30			ns
	t_{SL}		30			
TSYNC or TSSYNCIO Setup to TCLK or TSYSCLK falling	t_{SU}		20		$t_{CH} - 5$ or $t_{SH} - 5$	ns
TSYNC or TSSYNCIO Pulse Width	t_{PW}	(Note 6)	50			ns
TSSYNCIO Pulse Width (Notes 7, 8)	t_{PW}		488			ns
			244			
			122			
			61			
TSER, TSIG Setup to TCLK, TSYSCLK Falling	t_{SU}		20			ns
TSER, TSIG Hold from TCLK, TSYSCLK Falling	t_{HD}		20			ns
Delay TCLK to TCHBLK, TCHCLK, TSYNC	t_{D2}				50	ns
Delay TSYSCLK to TCHCLK, TCHBLK	t_{D3}				50	ns
Delay BPCLK to TSSYNCIO (Note 7)	t_{D5}				5	ns

Note 1: The timing parameters in this table are guaranteed by design (GBD).

Note 2: T1 Mode.

Note 3: E1 Mode.

Note 4: RSYSCLK = 1.544MHz.

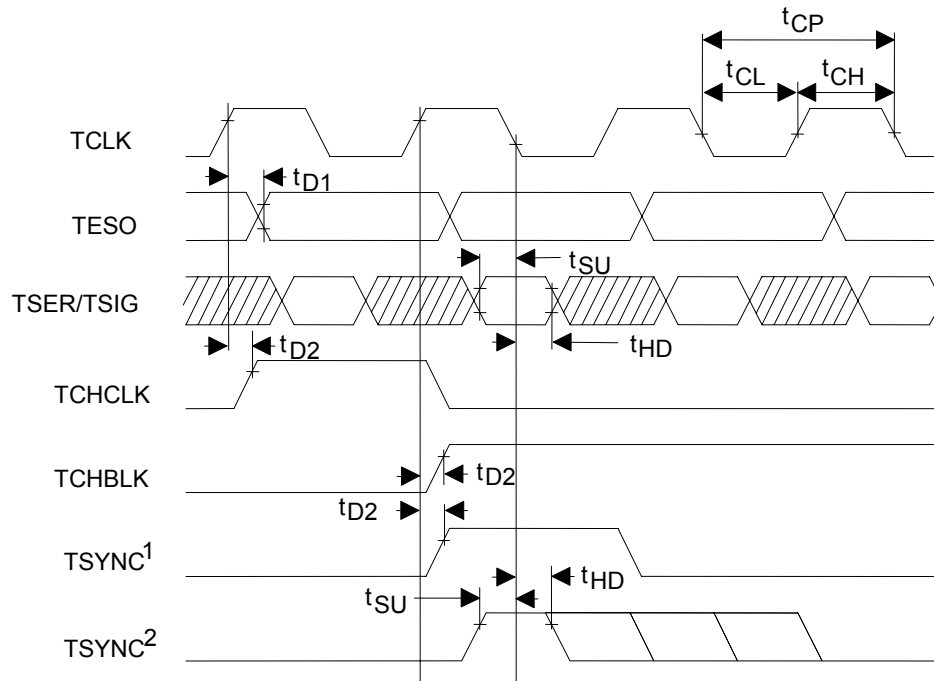
Note 5: RSYSCLK = 2.048MHz.

Note 6: TSSYNCIO configured as an input ([GTCR2.1](#) = 0).

Note 7: TSSYNCIO configured as an output ([GTCR2.1](#) = 1).

Note 8: Varies depending on the frequency of BPCLK.

Figure 12-8. Transmit Formatter Timing—Backplane



NOTE 1: TSYNC IS IN THE OUTPUT MODE.

NOTE 2: TSYNC IS IN THE INPUT MODE.

NOTE 3: TSER IS SAMPLED ON THE FALLING EDGE OF TCLK WHEN THE TRANSMIT-SIDE ELASTIC STORE IS DISABLED.

NOTE 4: TCHCLK AND TCHBLK ARE SYNCHRONOUS WITH TCLK WHEN THE TRANSMIT-SIDE ELASTIC STORE IS DISABLED.

NOTE 5: NO RELATIONSHIP BETWEEN TCHCLK AND TCHBLK AND THE OTHER SIGNALS IS IMPLIED.

Figure 12-9. Transmit Formatter Timing, Elastic Store Enabled

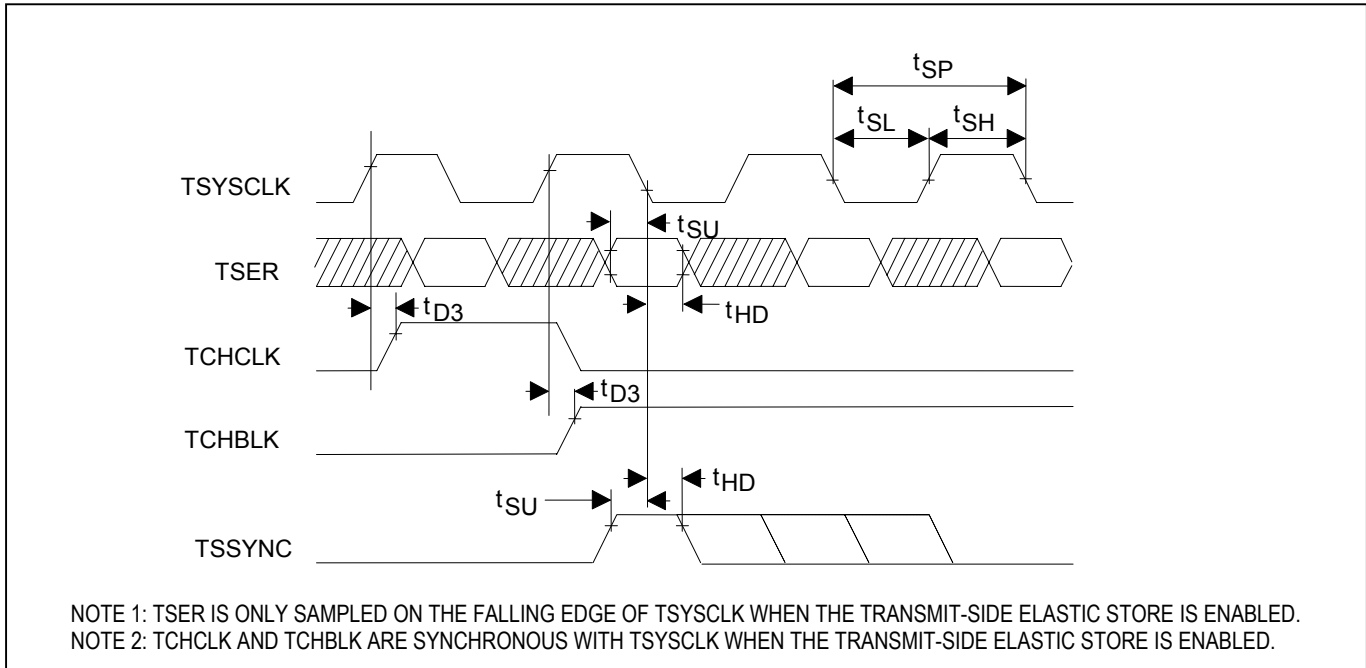


Figure 12-10. BPCLK Timing

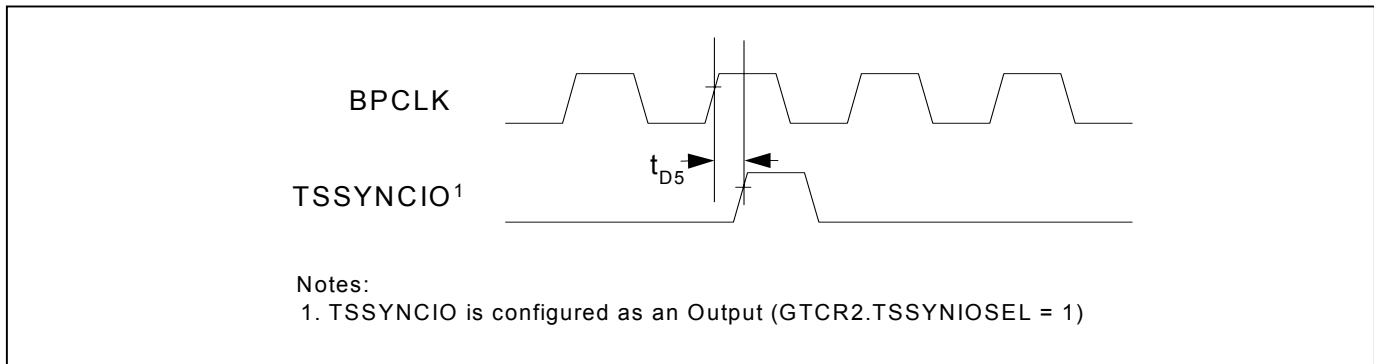
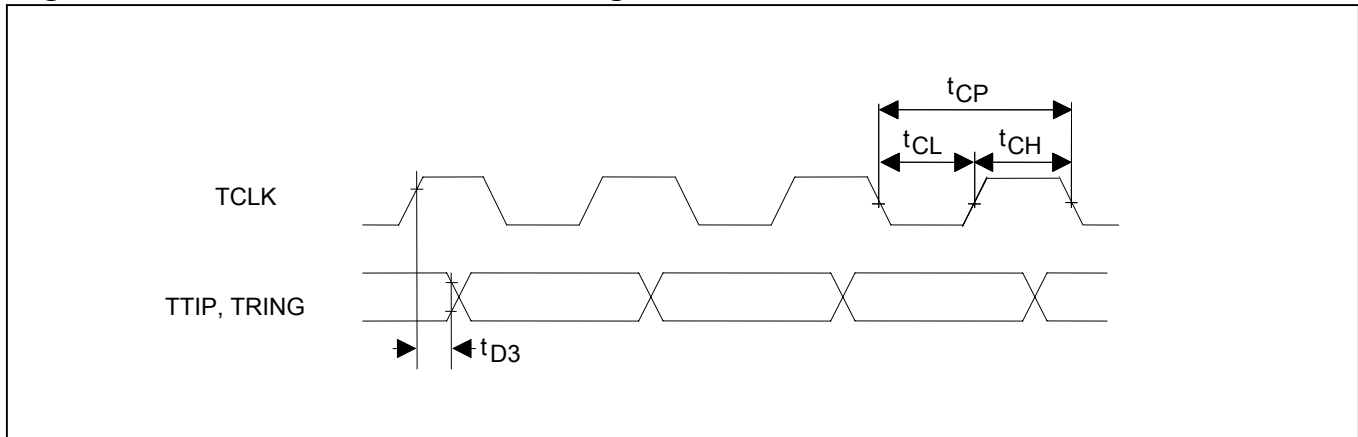


Figure 12-11. Transmit Formatter Timing—Line Side



12.2 JTAG Interface Timing

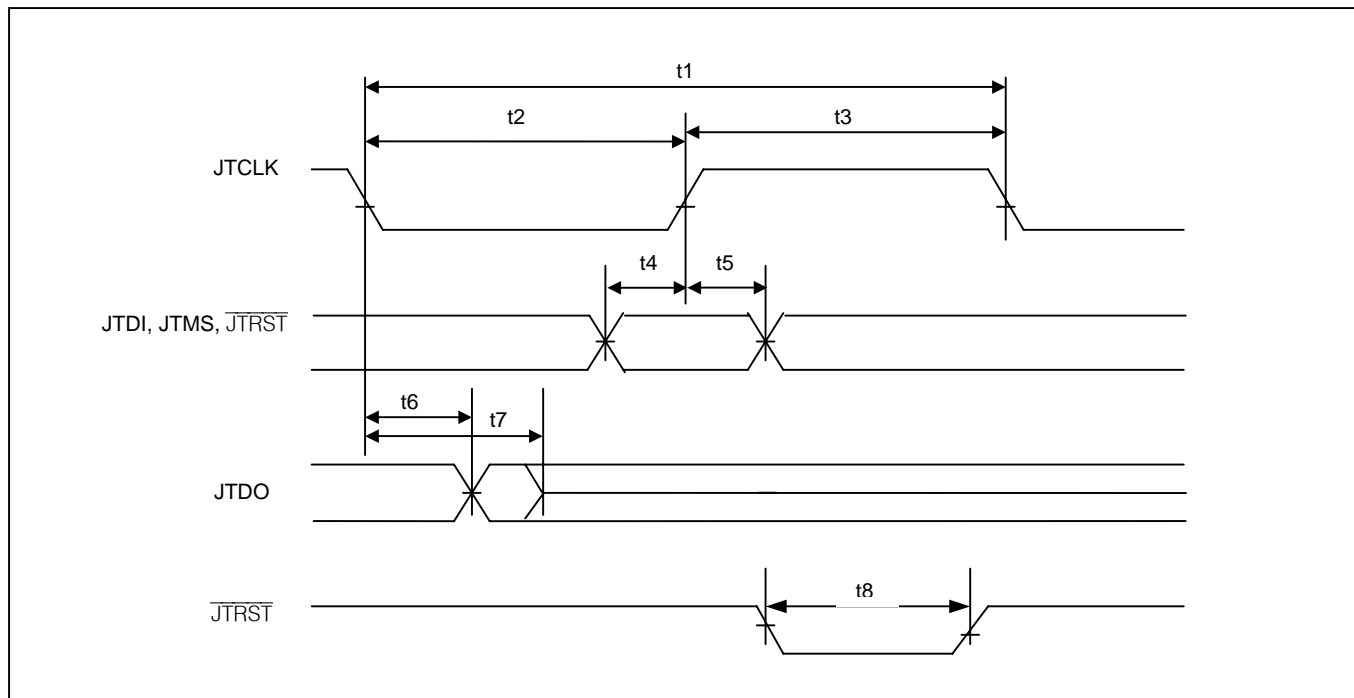
Table 12-4. JTAG Interface Timing

($V_{DD} = 3.3V \pm 5\%$, $T_A = -40^\circ\text{C}$ to $+85^\circ\text{C}$ for DS26524GN.) (See [Figure 12-12.](#))

PARAMETER	SYMBOL	CONDITIONS	MIN	TYP	MAX	UNITS
JTCLK Clock Period	t1			1000		ns
JTCLK Clock High:Low Time	t2:t3	(Note 1)	50	500		ns
JTCLK to JTDI, JTMS Setup Time	t4		5			ns
JTCLK to JTDI, JTMS Hold Time	t5		2			ns
JTCLK to JTDO Delay	t6		2		50	ns
JTCLK to JTDO High-Impedance Delay	t7		2		50	ns
$\overline{\text{JTRST}}$ Width Low Time	t8		100			ns

Note 1: Clock can be stopped high or low.

Figure 12-12. JTAG Interface Timing Diagram



12.3 System Clock AC Characteristics

Table 12-5. System Clock AC Characteristics

PARAMETER	SYMBOL	CONDITIONS	MIN	TYP	MAX	UNITS
REF_CLK Frequency			1.544			MHz
			2.048			
REF_CLK Duty Cycle			40		60	%
Gapped Clock Frequency		(Note 1)	43	45	60	MHz
Gapped Clock Duty Cycle			40		60	%

Note 1: The gapped clock is output on the RCHCLK pin when [RESCR](#).6 = 1.

13. JTAG BOUNDARY SCAN AND TEST ACCESS PORT

The DS26524 IEEE 1149.1 design supports the standard instruction codes SAMPLE:PRELOAD, BYPASS, and EXTEST. Optional public instructions included are HIGHZ, CLAMP, and IDCODE. See [Table 13-1](#). The DS26524 contains the following as required by IEEE 1149.1 Standard Test Access Port and Boundary Scan Architecture.

Test Access Port (TAP)

TAP Controller

Instruction Register

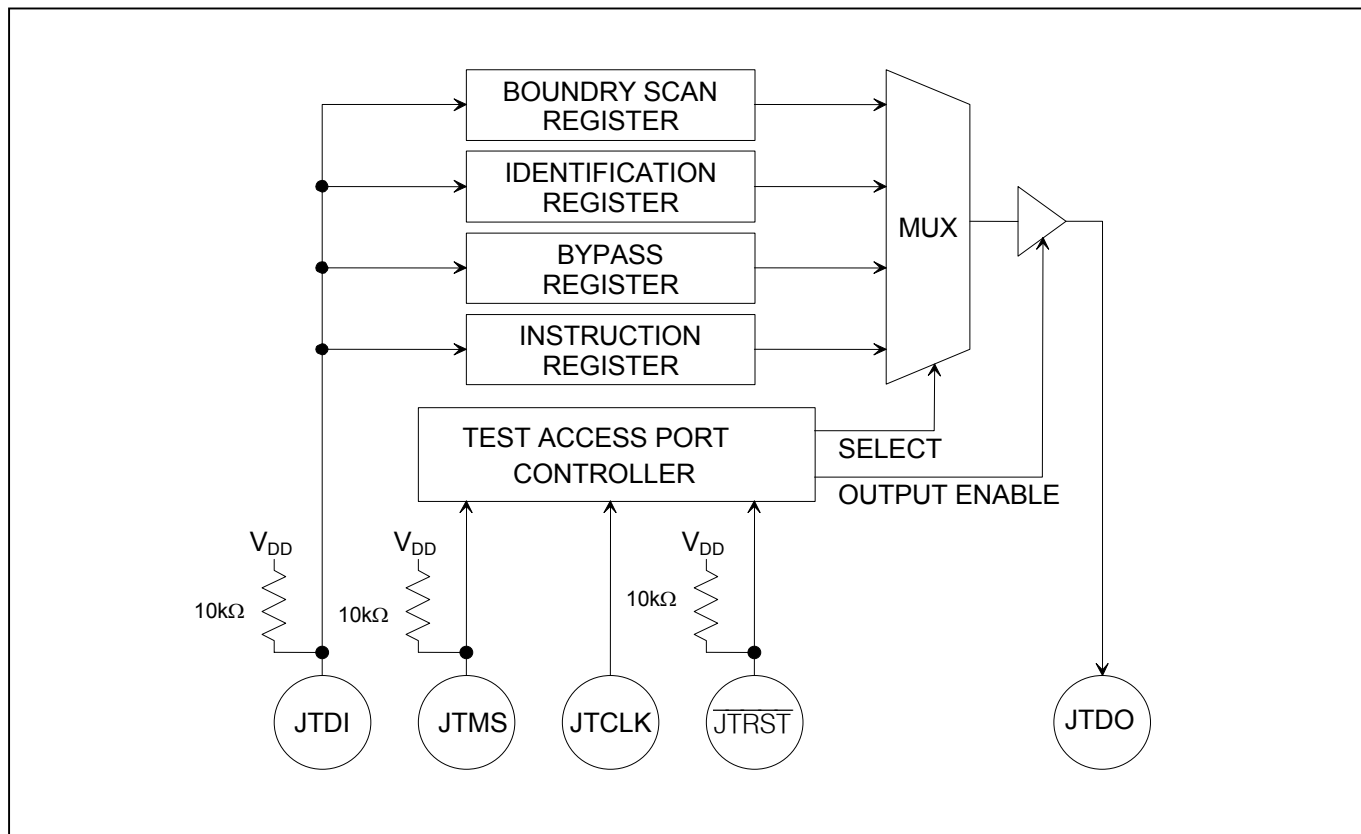
Bypass Register

Boundary Scan Register

Device Identification Register

The Test Access Port has the necessary interface pins: $\overline{\text{JTRST}}$, JTCLK, JTMS, JTDI, and JTDO. See the pin descriptions for details.

Figure 13-1. JTAG Functional Block Diagram



13.1 TAP Controller State Machine

The TAP controller is a finite state machine that responds to the logic level at JTMS on the rising edge of JTCLK. See [Figure 13-2](#).

13.1.1 Test-Logic-Reset

Upon power-up, the TAP controller is in the Test-Logic-Reset state. The instruction register contains the IDCODE instruction. All system logic of the device operates normally.

13.1.2 Run-Test-Idle

The Run-Test-Idle is used between scan operations or during specific tests. The instruction register and test registers remain idle.

13.1.3 Select-DR-Scan

All test registers retain their previous state. With JTMS LOW, a rising edge of JTCLK moves the controller into the Capture-DR state and initiates a scan sequence. JTMS HIGH during a rising edge on JTCLK moves the controller to the Select-IR-Scan state.

13.1.4 Capture-DR

Data can be parallel-loaded into the test data registers selected by the current instruction. If the instruction does not call for a parallel load or the selected register does not allow parallel loads, the test register remains at its current value. On the rising edge of JTCLK, the controller goes to the Shift-DR state if JTMS is LOW, or it goes to the Exit1-DR state if JTMS is HIGH.

13.1.5 Shift-DR

The test data register selected by the current instruction is connected between JTDI and JTDO and shifts data one stage towards its serial output on each rising edge of JTCLK. If a test register selected by the current instruction is not placed in the serial path, it maintains its previous state.

13.1.6 Exit1-DR

While in this state, a rising edge on JTCLK puts the controller in the Update-DR state, which terminates the scanning process, if JTMS is HIGH. A rising edge on JTCLK with JTMS LOW puts the controller in the Pause-DR state.

13.1.7 Pause-DR

Shifting of the test registers is halted while in this state. All test registers selected by the current instruction retain their previous state. The controller remains in this state while JTMS is LOW. A rising edge on JTCLK with JTMS HIGH puts the controller in the Exit2-DR state.

13.1.8 Exit2-DR

A rising edge on JTCLK with JTMS HIGH while in this state puts the controller in the Update-DR state and terminates the scanning process. A rising edge on JTCLK with JTMS LOW enters the Shift-DR state.

13.1.9 Update-DR

A falling edge on JTCLK while in the Update-DR state latches the data from the shift register path of the test registers into the data output latches. This prevents changes at the parallel output due to changes in the shift register.

13.1.10 Select-IR-Scan

All test registers retain their previous state. The instruction register remains unchanged during this state. With JTMS LOW, a rising edge on JTCLK moves the controller into the Capture-IR state and initiates a scan sequence for the instruction register. JTMS HIGH during a rising edge on JTCLK puts the controller back into the Test-Logic-Reset state.

13.1.11 Capture-IR

The Capture-IR state is used to load the shift register in the instruction register with a fixed value. This value is loaded on the rising edge of JTCLK. If JTMS is HIGH on the rising edge of JTCLK, the controller enters the Exit1-IR state. If JTMS is LOW on the rising edge of JTCLK, the controller enters the Shift-IR state.

13.1.12 Shift-IR

In this state, the shift register in the instruction register is connected between JTDI and JTDO and shifts data one stage for every rising edge of JTCLK towards the serial output. The parallel register, as well as all test registers, remains at their previous states. A rising edge on JTCLK with JTMS HIGH moves the controller to the Exit1-IR state. A rising edge on JTCLK with JTMS LOW keeps the controller in the Shift-IR state while moving data one stage through the instruction shift register.

13.1.13 Exit1-IR

A rising edge on JTCLK with JTMS LOW puts the controller in the Pause-IR state. If JTMS is HIGH on the rising edge of JTCLK, the controller enters the Update-IR state and terminates the scanning process.

13.1.14 Pause-IR

Shifting of the instruction shift register is halted temporarily. With JTMS HIGH, a rising edge on JTCLK puts the controller in the Exit2-IR state. The controller remains in the Pause-IR state if JTMS is LOW during a rising edge on JTCLK.

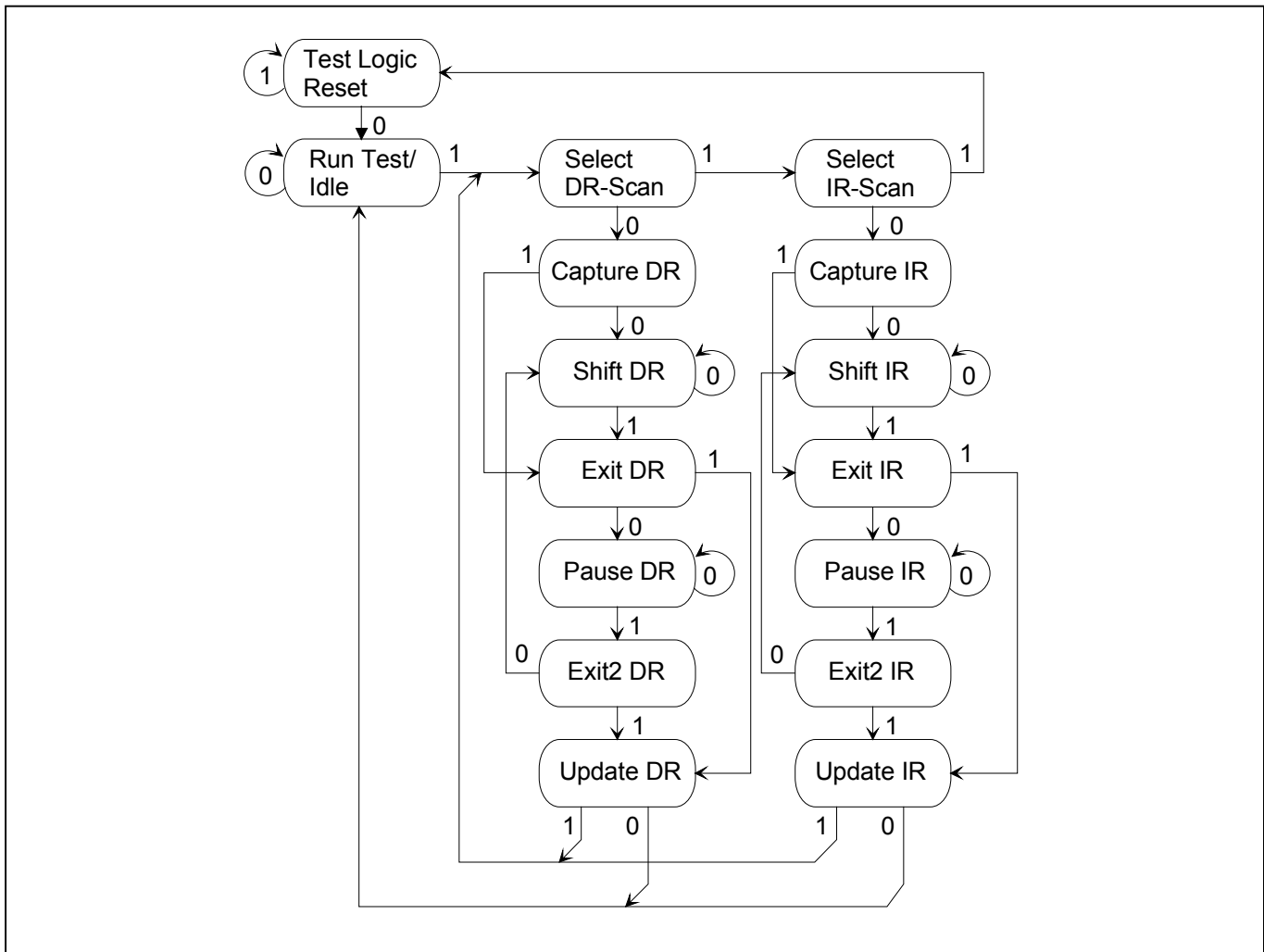
13.1.15 Exit2-IR

A rising edge on JTCLK with JTMS LOW puts the controller in the Update-IR state. The controller loops back to Shift-IR if JTMS is HIGH during a rising edge of JTCLK in this state.

13.1.16 Update-IR

The instruction code shifted into the instruction shift register is latched into the parallel output on the falling edge of JTCLK as the controller enters this state. Once latched, this instruction becomes the current instruction. A rising edge on JTCLK with JTMS LOW puts the controller in the Run-Test-Idle state. With JTMS HIGH, the controller enters the Select-DR-Scan state.

Figure 13-2. TAP Controller State Diagram



13.2 Instruction Register

The instruction register contains a shift register as well as a latched parallel output, and is 3 bits in length. When the TAP controller enters the Shift-IR state, the instruction shift register will be connected between JTDI and JTDO. While in the Shift-IR state, a rising edge on JTCLK with JTMS LOW will shift the data one stage towards the serial output at JTDO. A rising edge on JTCLK in the Exit1-IR state or the Exit2-IR state with JTMS HIGH will move the controller to the Update-IR state. The falling edge of that same JTCLK will latch the data in the instruction shift register to the instruction parallel output. Instructions supported by the DS26524 and its respective operational binary codes are shown in [Table 13-1](#).

Table 13-1. Instruction Codes for IEEE 1149.1 Architecture

INSTRUCTION	SELECTED REGISTER	INSTRUCTION CODES
SAMPLE:PRELOAD	Boundary Scan	010
BYPASS	Bypass	111
EXTEST	Boundary Scan	000
CLAMP	Bypass	011
HIGHZ	Bypass	100
IDCODE	Device Identification	001

13.2.1 SAMPLE:PRELOAD

This is a mandatory instruction for the IEEE 1149.1 specification. This instruction supports two functions. The digital I/Os of the device can be sampled at the boundary scan register without interfering with the normal operation of the device by using the Capture-DR state. SAMPLE:PRELOAD also allows the device to shift data into the boundary scan register via JTDI using the Shift-DR state.

13.2.2 BYPASS

When the BYPASS instruction is latched into the parallel instruction register, JTDI connects to JTDO through the one-bit bypass test register. This allows data to pass from JTDI to JTDO without affecting the device's normal operation.

13.2.3 EXTEST

This allows testing of all interconnections to the device. When the EXTEST instruction is latched in the instruction register, the following actions occur. Once enabled via the Update-IR state, the parallel outputs of all digital output pins will be driven. The boundary scan register will be connected between JTDI and JTDO. The Capture-DR will sample all digital inputs into the boundary scan register.

13.2.4 CLAMP

All digital outputs of the device will output data from the boundary scan parallel output while connecting the bypass register between JTDI and JTDO. The outputs will not change during the CLAMP instruction.

13.2.5 HIGHZ

All digital outputs of the device will be placed in a high-impedance state. The BYPASS register will be connected between JTDI and JTDO.

13.2.6 IDCODE

When the IDCODE instruction is latched into the parallel instruction register, the identification test register is selected. The device identification code will be loaded into the identification register on the rising edge of JTCLK following entry into the Capture-DR state. Shift-DR can be used to shift the identification code out serially via JTDO. During Test-Logic-Reset, the identification code is forced into the instruction register's parallel output. The ID code will always have a 1 in the LSB position. The next 11 bits identify the manufacturer's JEDEC number and number of continuation bytes followed by 16 bits for the device and 4 bits for the version.

13.3 JTAG ID Codes

Table 13-2. ID Code Structure

DEVICE	REVISION ID[31:28]	DEVICE CODE ID[27:12]	MANUFACTURER'S CODE ID[11:1]	REQUIRED ID[0]
DS26528	Consult factory	0000000000110111	00010100001	1
DS26524	Consult factory	0000000000111001	00010100001	1

13.4 Test Registers

IEEE 1149.1 requires a minimum of two test registers: the bypass register and the boundary scan register. An optional test register has been included with the DS26524 design. This test register is the identification register and is used in conjunction with the IDCODE instruction and the Test-Logic-Reset state of the TAP controller.

13.4.1 Boundary Scan Register

This register contains both a shift register path and a latched parallel output for all control cells and digital I/O cells, and is n bits in length. See [Table 13-3](#) for all the cell bit locations and definitions.

13.4.2 Bypass Register

This is a single one-bit shift register used in conjunction with the BYPASS, CLAMP, and HIGHZ instructions, which provides a short path between JTDI and JTDO.

13.4.3 Identification Register

The identification register contains a 32-bit shift register and a 32-bit latched parallel output. This register is selected during the IDCODE instruction and when the TAP controller is in the Test-Logic-Reset state.

Table 13-3. Boundary Scan Control Bits

CELL#	NAME	TYPE	CONTROL CELL
0	—	controlr	
1	rser(1)	output3	0
2	—	controlr	
3	rm_rfsync(1)	output3	2
4	rm_rfsync(1)	observe_only	
5	—	controlr	
6	rsync(1)	output3	5
7	rsync(1)	observe_only	
8	—	controlr	
9	tsig(1)	output3	8
10	tsig(1)	observe_only	
11	—	controlr	
12	tsync(1)	output3	11
13	tsync(1)	observe_only	
14	tser(1)	observe_only	
15	tclk(1)	observe_only	
16	—	controlr	
17	tchblk_clk(1)	output3	16
18	tchblk_clk(1)	observe_only	
19	—	controlr	
20	rchblk_clk(2)	output3	19
21	rchblk_clk(2)	observe_only	
22	—	controlr	
23	rsg(2)	output3	22
24	rsg(2)	observe_only	
25	—	controlr	
26	rfl_ttc(2)	output3	25
27	—	controlr	
28	al_rsig_flos(2)	output3	27
29	—	controlr	
30	rser(2)	output3	29
31	—	controlr	
32	rm_rfsync(2)	output3	31
33	rm_rfsync(2)	observe_only	
34	—	controlr	
35	rsync(2)	output3	34
36	rsync(2)	observe_only	
37	—	controlr	
38	tsig(2)	output3	37
39	tsig(2)	observe_only	

CELL#	NAME	TYPE	CONTROL CELL
40	—	controlr	
41	tsync(2)	output3	40
42	tsync(2)	observe_only	
43	tser(2)	observe_only	
44	tclk(2)	observe_only	
45	—	controlr	
46	tchblk_clk(2)	output3	45
47	tchblk_clk(2)	observe_only	
48	mclk	observe_only	
49	—	controlr	
50	refclkio	output3	49
51	refclkio	observe_only	
52	—	controlr	
53	bpclk	output3	52
54	a(12)	observe_only	
55	a(11)	observe_only	
56	a(10)	observe_only	
57	digio_en	observe_only	
58	a(9)	observe_only	
59	a(8)	observe_only	
60	a(7)	observe_only	
61	a(6)	observe_only	
62	a(5)	observe_only	
63	a(4)	observe_only	
64	a(3)	observe_only	
65	a(2)	observe_only	
66	a(1)	observe_only	
67	a(0)	observe_only	
68	—	controlr	
69	tchblk_clk(7)	output3	68
70	tchblk_clk(7)	observe_only	
71	tclk(7)	observe_only	
72	tser(7)	observe_only	
73	—	controlr	
74	tsync(7)	output3	73
75	tsync(7)	observe_only	
76	—	controlr	
77	tsig(7)	output3	76
78	tsig(7)	observe_only	
79	—	controlr	
80	rsync(7)	output3	79
81	rsync(7)	observe_only	

CELL#	NAME	TYPE	CONTROL CELL
82	—	controlr	
83	rm_rfsync(7)	output3	82
84	rm_rfsync(7)	observe_only	
85	—	controlr	
86	rser(7)	output3	85
87	—	controlr	
88	al_rsigf_flos(7)	output3	87
89	—	controlr	
90	rfl_ltc(7)	output3	89
91	—	controlr	
92	rsig(7)	output3	91
93	rsig(7)	observe_only	
94	—	controlr	
95	rchblk_clk(7)	output3	94
96	rchblk_clk(7)	observe_only	
97	—	controlr	
98	tchblk_clk(8)	output3	97
99	tchblk_clk(8)	observe_only	
100	tclk(8)	observe_only	
101	tser(8)	observe_only	
102	—	controlr	
103	tsync(8)	output3	102
104	tsync(8)	observe_only	
105	—	controlr	
106	tsig(8)	output3	105
107	tsig(8)	observe_only	
108	—	controlr	
109	rsync(8)	output3	108
110	rsync(8)	observe_only	
111	—	controlr	
112	rm_rfsync(8)	output3	111
113	rm_rfsync(8)	observe_only	
114	—	controlr	
115	rser(8)	output3	114
116	—	controlr	
117	al_rsigf_flos(8)	output3	116
118	—	controlr	
119	rfl_ltc(8)	output3	118
120	—	controlr	
121	rclk(8)	output3	120
122	rclk(8)	observe_only	
123	—	controlr	

CELL#	NAME	TYPE	CONTROL CELL
124	rclk(7)	output3	123
125	rclk(7)	observe_only	
126	—	controlr	
127	rsig(8)	output3	126
128	rsig(8)	observe_only	
129	—	controlr	
130	rchblk_clk(8)	output3	129
131	rchblk_clk(8)	observe_only	
132	—	controlr	
133	rclk(6)	output3	132
134	rclk(6)	observe_only	
135	—	controlr	
136	rclk(5)	output3	135
137	rclk(5)	observe_only	
138	resetb	observe_only	
139	txen_b	observe_only	
140	bts	observe_only	
141	rsysclk	observe_only	
142	—	controlr	
143	tssyncio	output3	142
144	tssyncio	observe_only	
145	tsysclk	observe_only	
146	—	controlr	
147	rchblk_clk(6)	output3	146
148	rchblk_clk(6)	observe_only	
149	—	controlr	
150	rsig(6)	output3	149
151	rsig(6)	observe_only	
152	—	controlr	
153	rif_ltc(6)	output3	152
154	—	controlr	
155	al_rsigf_flos(6)	output3	154
156	—	controlr	
157	rser(6)	output3	156
158	—	controlr	
159	rm_rfsync(6)	output3	158
160	rm_rfsync(6)	observe_only	
161	—	controlr	
162	rsync(6)	output3	161
163	rsync(6)	observe_only	
164	—	controlr	
165	tsig(6)	output3	164

CELL#	NAME	TYPE	CONTROL CELL
166	tsig(6)	observe_only	
167	—	controlr	
168	tsync(6)	output3	167
169	tsync(6)	observe_only	
170	tser(6)	observe_only	
171	tclk(6)	observe_only	
172	—	controlr	
173	tchblk_clk(6)	output3	172
174	tchblk_clk(6)	observe_only	
175	—	controlr	
176	rchblk_clk(5)	output3	175
177	rchblk_clk(5)	observe_only	
178	—	controlr	
179	rsig(5)	output3	178
180	rsig(5)	observe_only	
181	—	controlr	
182	rif_ltc(5)	output3	181
183	—	controlr	
184	al_rsigf_flos(5)	output3	183
185	—	controlr	
186	rser(5)	output3	185
187	—	controlr	
188	rm_rfsync(5)	output3	187
189	rm_rfsync(5)	observe_only	
190	—	controlr	
191	rsync(5)	output3	190
192	rsync(5)	observe_only	
193	—	controlr	
194	tsig(5)	output3	193
195	tsig(5)	observe_only	
196	—	controlr	
197	tsync(5)	output3	196
198	tsync(5)	observe_only	
199	tser(5)	observe_only	
200	tclk(5)	observe_only	
201	—	controlr	
202	tchblk_clk(5)	output3	201
203	tchblk_clk(5)	observe_only	
204	—	controlr	
205	intb	output3	204
206	d(7)	output3	220
207	d(7)	observe_only	

CELL#	NAME	TYPE	CONTROL CELL
208	d(6)	output3	220
209	d(6)	observe_only	
210	d(5)	output3	220
211	d(5)	observe_only	
212	d(4)	output3	220
213	d(4)	observe_only	
214	d(3)	output3	220
215	d(3)	observe_only	
216	d(2)	output3	220
217	d(2)	observe_only	
218	d(1)	output3	220
219	d(1)	observe_only	
220	—	controlr	
221	d(0)	output3	220
222	d(0)	observe_only	
223	rdb_dsb	observe_only	
224	wrb_rwb	observe_only	
225	csb	observe_only	
226	—	controlr	
227	tchblk_clk(4)	output3	226
228	tchblk_clk(4)	observe_only	
229	tclk(4)	observe_only	
230	tser(4)	observe_only	
231	—	controlr	
232	tsync(4)	output3	231
233	tsync(4)	observe_only	
234	—	controlr	
235	tsig(4)	output3	234
236	tsig(4)	observe_only	
237	—	controlr	
238	rsync(4)	output3	237
239	rsync(4)	observe_only	
240	—	controlr	
241	rm_rfsync(4)	output3	240
242	rm_rfsync(4)	observe_only	
243	—	controlr	
244	rser(4)	output3	243
245	—	controlr	
246	al_rsigf_flos(4)	output3	245
247	—	controlr	
248	rif_ltc(4)	output3	247
249	—	controlr	

CELL#	NAME	TYPE	CONTROL CELL
250	rsig(4)	output3	249
251	rsig(4)	observe_only	
252	—	controlr	
253	rchblk_clk(4)	output3	252
254	rchblk_clk(4)	observe_only	
255	—	controlr	
256	tchblk_clk(3)	output3	255
257	tchblk_clk(3)	observe_only	
258	tclk(3)	observe_only	
259	tser(3)	observe_only	
260	—	controlr	
261	tsync(3)	output3	260
262	tsync(3)	observe_only	
263	—	controlr	
264	tsig(3)	output3	263
265	tsig(3)	observe_only	
266	—	controlr	
267	rsync(3)	output3	266
268	rsync(3)	observe_only	
269	—	controlr	
270	rm_rfsync(3)	output3	269
271	rm_rfsync(3)	observe_only	
272	—	controlr	
273	rser(3)	output3	272
274	—	controlr	
275	al_rsigf_flos(3)	output3	274
276	—	controlr	
277	rif_ltc(3)	output3	276
278	—	controlr	
279	rsig(3)	output3	278
280	rsig(3)	observe_only	
281	—	controlr	
282	rchblk_clk(3)	output3	281
283	rchblk_clk(3)	observe_only	
284	—	controlr	
285	rclk(4)	output3	284
286	rclk(4)	observe_only	
287	—	controlr	
288	rclk(3)	output3	287
289	rclk(3)	observe_only	
290	—	controlr	
291	rclk(2)	output3	290

CELL#	NAME	TYPE	CONTROL CELL
292	rclk(2)	observe_only	
293	—	controlr	
294	rclk(1)	output3	293
295	rclk(1)	observe_only	
296	—	controlr	
297	rchblk_clk(1)	output3	296
298	rchblk_clk(1)	observe_only	

CELL#	NAME	TYPE	CONTROL CELL
299	—	controlr	
300	rsig(1)	output3	299
301	rsig(1)	observe_only	
302	—	controlr	
303	r1f_ltc(1)	output3	302
304	—	controlr	
305	al_rsigf_flos(1)	output3	304

14. PIN CONFIGURATION

Figure 14-1. Pin Configuration—256-Ball TE-CSBGA

	1	2	3	4	5	6	7	8	9	10	11	12	13	14	15	16	
A	TTIP1	TTIP1	TRING1	RSYNC1	TCHBLK/ CLK1	TSIG2	REFCLKIO	A11	A7	A1	DVSS	N.C.	DVSS	N.C.	N.C.	N.C.	
B	ATVDD1	ATVSS1	TRING1	TSYNC1	RCHBLK/ CLK2	RSYNC2	MCLK	A10	A8	A2	DVSS	N.C.	DVSS	N.C.	ATVSS8	ATVDD8	
C	RTIP1	RRING1	AL/ RSIG/ FLOS1	RMSYNC1/ RFSYNC1	TCLK1	RMSYNC2/ RFSYNC2	TCHBLK/ CLK2	A12	A6	A0	DVSS	N.C.	DVSS	N.C.	N.C.	N.C.	
D	ARVDD1	ARVSS1	RLF/ LTC1	RSIG1	TSIG1	RSER2	TCLK2	DIGIOEN	A5	N.C.	N.C.	DVSS	DVSS	N.C.	ARVSS8	ARVDD8	
E	ARVDD2	ARVSS2	RLF/ LTC2	RCHBLK/ CLK1	RSER1	RSIG2	TSER2	BPCLK	A4	DVSS	N.C.	N.C.	N.C.	N.C.	ARVSS7	ARVDD7	
F	RTIP2	RRING2	AL/ RSIG/ FLOS2	RCLK1	JTCLK	TSER1	TSYNC2	A9	A3	DVSS	N.C.	N.C.	N.C.	N.C.	N.C.	N.C.	
G	ATVDD2	ATVSS2	TRING2	RCLK2	DVDD	DVDD	DVDD	DVDD	DVDD	DVDD	DVDD	DVDD	DVDD	N.C.	N.C.	ATVSS7	ATVDD7
H	TTIP2	TTIP2	TRING2	JTDI	DVDDIO	DVDDIO	ACVDD	DVDD	DVDD	DVDDIO	DVDDIO	DVSS	DVSS	N.C.	N.C.	N.C.	
J	TTIP3	TTIP3	TRING3	JTDO	DVSSIO	DVSSIO	ACVSS	DVSS	DVSS	DVSSIO	DVSSIO	$\overline{\text{RESETB}}$	N.C.	N.C.	N.C.	N.C.	
K	ATVDD3	ATVSS3	TRING3	JTMS	DVSS	DVSS	DVSS	DVSS	DVSS	DVSS	DVSS	DVSS	N.C.	N.C.	ATVSS6	ATVDD6	
L	RTIP3	RRING3	AL/ RSIG/ FLOS3	RCLK3	$\overline{\text{JTRST}}$	RCHBLK/ CLK3	TCHBLK/ CLK3	TCLK4	D1	DVSS	DVSS	RSYSCLK	TXENABLE	N.C.	N.C.	N.C.	
M	ARVDD3	ARVSS3	RLF/ LTC3	RCLK4	RSIG3	TSYNC3	TSYNC4	$\overline{\text{RDE}}/DSB$	D5	DVSS	N.C.	N.C.	BTS	N.C.	ARVSS6	ARVDD6	
N	ARVDD4	ARVSS4	RLF/ LTC4	RSER3	RSYNC3	RSER4	TSER4	D0	D6	DVSS	DVSS	N.C.	TSSYNCIO	N.C.	ARVSS5	ARVDD5	
P	RTIP4	RRING4	AL/ RSIG/ FLOS4	RMSYNC3/ RFSYNC3	TCLK3	RMSYNC4/ RFSYNC4	TCHBLK/ CLK4	D2	N.C.	N.C.	N.C.	DVSS	TSYSCLK	N.C.	N.C.	N.C.	
R	ATVDD4	ATVSS4	TRING4	TSER3	RSIG4	TSIG4	$\overline{\text{WRB}}/RWB$	D4	$\overline{\text{INTB}}$	DVSS	N.C.	DVSS	N.C.	N.C.	ATVSS5	ATVDD5	
T	TTIP4	TTIP4	TRING4	TSIG3	RCHBLK/ CLK4	RSYNC4	$\overline{\text{CSB}}$	D3	D7	DVSS	N.C.	DVSS	N.C.	N.C.	N.C.	N.C.	

16. DOCUMENT REVISION HISTORY

REVISION DATE	DESCRIPTION	PAGES CHANGED
102106	New product release.	—
012307	Corrected TSYNC1 ball (from B1 to B4).	20
	Corrected RSYNC3 and RSYNC4 (previously said RSYNC2 for both).	21
	Corrected DVDD balls—previous revision stated “G5, G12” but this is “G5–G12.”	24
	Figure 8-11: In Note 4, changed S2/S3 to S3/S4 and changed S4/S5 to S5/S6; added Note 6.	72
060607	Added commercial temperature range devices (DS26524G and DS26524G+) to <i>Ordering Information</i> table.	1
	Added commercial temperature range to <i>Absolute Maximum Ratings</i> and added “for DS26524GN” to the temp range for Table 11-1, Table 11-3, Table 12-1, Table 12-2, Table 12-3, and Table 12-4.	248, 250, 253, 256, 259
	In Table 11-4, added commercial temperature range to Ambient Temperature.	249
112907	Elaborated on pin descriptions for TCLK, TCHCLK, and RCHCLK.	20, 22
	In the <i>Absolute Maximum Ratings</i> section, added GBD note for cold test (Note 1).	248

Looking for pricing, stock, or lifecycle information?

Click below to explore more details on WIN SOURCE:

 [View DS26524G+](#) on WIN SOURCE

 [Maxim Integrated](#) Information

Optimize Your Supply Chain with WIN SOURCE Solutions

-  Global Sourcing Solution
-  Obsolete Management
-  Cost Control Management
-  Shortage Management
-  Alternative Solution
-  Excess Inventory Management