



**THE DATASHEET OF
DS2714E+**



www.maxim-ic.com

GENERAL DESCRIPTION

The DS2714 is ideal for standalone charging of 1 to 4 AA or AAA NiMH “loose” cells. NiCd cells can also be charged. Temperature, voltage and charge time are monitored to provide proper fast charging control algorithms for Nickel Metal Hydride (NiMH) batteries. Battery tests are included to detect defective or inappropriate cells such as Alkaline primary batteries. The DS2714 supports a parallel charging topology, with independent monitoring and control of each cell.

APPLICATIONS

Desktop/Standalone Chargers (AAA/AA)
Digital Still Cameras
Music Players
Games
Toys

FEATURES

- Charges 1 to 4 NiMH Cells
- Detects and Avoids Charging Alkaline Cells
- Pre-Charges Deeply Depleted Cells
- Fast Charges NiMH with $-\Delta V$ Termination Sensitivity of 2mV (typ)
- Monitors Voltage, Temperature and Time for Safety and Secondary Termination
- Works with Regulated Charge Current Source
- Drives PNP Type Pass Element
- Compatible with Integrated Primary-Side PWM Controllers
- 20-pin TSSOP Package

ORDERING INFORMATION

PART	MARKING	PIN-PACKAGE
DS2714E+	DS2714	20 TSSOP
DS2714E+T&R	DS2714	20 TSSOP Tape-and-Reel

+Denotes lead-free package.

CHARGE TOPOLOGY

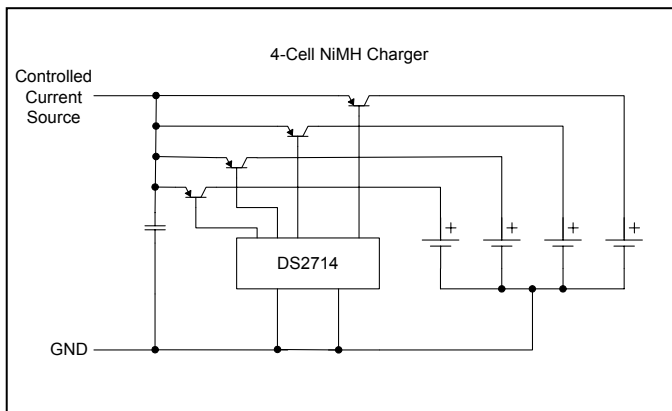

PIN CONFIGURATION

CC1	1	20	THM2
CC2	2	19	THM1
CC3	3	18	VP4
CC4	4	17	VP3
LED1	5	16	VP2
LED2	6	15	VP1
VSS	7	14	VSS
LED3	8	13	VDD
LED4	9	12	TMR
DMSSEL	10	11	CTST

TSSOP

Note: Some revisions of this device may incorporate deviations from published specifications known as errata. Multiple revisions of any device may be simultaneously available through various sales channels. For information about device errata, click here: www.maxim-ic.com/errata.

ABSOLUTE MAXIMUM RATINGS

Voltage Range on Any Pin Relative to V_{SS}	-0.3V to +6V
Voltage on DMSEL	$V_{DD} + 0.3V$
Continuous Sink Current CC1-4, LED1-4	20mA
Operating Temperature Range	-40°C to +85°C
Storage Temperature Range	-55°C to +125°C
Soldering Temperature	See IPC/JEDECJ-STD-020A

Stresses beyond those listed under "Absolute Maximum Ratings" may cause permanent damage to the device. These are stress ratings only, and functional operation of the device at these or any other conditions beyond those indicated in the operational sections of the specifications is not implied. Exposure to the absolute maximum rating conditions for extended periods may affect device reliability.

RECOMMENDED DC OPERATING CONDITIONS

($4.0V \leq V_{DD} \leq 5.5V$; $T_A = -20^\circ C$ to $+70^\circ C$)

PARAMETER	SYMBOL	CONDITIONS	MIN	TYP	MAX	UNITS
Supply Voltage	V_{DD}	(Note 1)	4.0		5.5	V
Input Voltage Range		LEDx, DMSEL	-0.3		5.5	V

DC ELECTRICAL CHARACTERISTICS

($4.0V \leq V_{DD} \leq 5.5V$; $T_A = -20^\circ C$ to $+70^\circ C$. Unless otherwise noted.)

PARAMETER	SYMBOL	CONDITIONS	MIN	TYP	MAX	UNITS
Supply Current, V_{DD}	I_{DD}	Operating mode		500	750	μA
Output Voltage Low, CC1-4, LED1-4	V_{OL1}	$V_{DD} = 5.0V$, $I_{OL} = 20mA$ (Note 1)			1.0	V
Leakage Current, CC1-4 LED1-4	I_{LKG}	$V_{DD} = 5.0V$, Output inactive	-1		+1	μA
Threshold Voltage, $-\Delta V$ Termination	$V_{-\Delta V}$	After t_{THO}	1.0	2.0	3.0	mV
Mode Test Current, DMSEL	I_{MTST}	Pulse high/low once <5ms after power-up	-	5	15	μA
Input Logic High, DMSEL,	V_{IH}	(Note 1)	$V_{DD} - 0.2V$			V
Input Logic Low, DMSEL,	V_{IL}	(Note 1)			0.2	V
Input Leakage Current, DMSEL	I_{IL1}	After power-up mode select, DMSEL = V_{DD} or V_{SS}	-1		+1	μA
Threshold Voltage, Cell Test Accuracy	$V_{CTST-ACC}$	$R_{TMR} = 80K\Omega$	-15		15	%
Threshold Voltage, Cell Test Range	$V_{CTST-RANGE}$		32		400	mV
Threshold Voltage, Cell Voltage Low	$V_{BAT-LOW}$	CC1 = CC2 = hi-Z (Note 1, 2)	0.9	1.0	1.1	V
Threshold Voltage, Cell Voltage Max1	$V_{BAT-MAX1}$	CC1 = CC2 = hi-Z (Note 1, 2)	1.55	1.65	1.75	V
Threshold Voltage, Cell Voltage Max2	$V_{BAT-MAX2}$	CC1, CC2 active (Note 1, 2)	1.64	1.75	1.86	V
Threshold Voltage, Thermistor - Min	$V_{THM-MIN}$	(Note 1, 2, 6)		$V_{DD} \times 0.73$		V
Threshold Voltage, Thermistor - Max	$V_{THM-MAX}$	(Note 1, 2, 6)	0.30	$V_{DD} \times 0.33$	0.36	V
Threshold Voltage, Thermistor - Stop	$V_{THM-STOP}$	(Note 1, 2, 6)		$V_{DD} \times 0.29$		V
Threshold Current, TMR Pin Suspend	$I_{TMR-SUS}$			0.1	0.5	μA

PARAMETER	SYMBOL	CONDITIONS	MIN	TYP	MAX	UNITS
Presence Test Current, VP1-4	I_{PTST}			10	15	μA
Reverse Leakage Current, VP1, VP2, VP3, VP4	I_{LKGR}	$V_{DD} = 0V, V_{Px} = 1.5V$			2	μA

ELECTRICAL CHARACTERISTICS: TIMING

($4.0V \leq V_{DD} \leq 5.5V$; $T_A = -20^\circ C$ to $+70^\circ C$. Unless otherwise noted.)

PARAMETER	SYMBOL	CONDITIONS	MIN	TYP	MAX	UNITS
Internal Timebase Period	t_{BASE}	(Note 5)		0.48		s
Internal Timebase Accuracy			-10		+10	%
Duty Factor, Fast Charge	DF1	CCx		0.234		
Duty Factor, Pre-Charge/Top-Off	DF2	CCx		0.0625		
Duty Factor, Maintenance Charge	DF3	CCx Note 4		0.0078		
Cell Test Interval	t_{CTST}	(Note 3)		31		s
Pre-Charge Time-out	t_{PCHG}	$V_{CELL} < V_{BAT-MIN}$	30.6	34	37.4	minutes
Fast Charge Termination Hold-Off Period	t_{THO}		3.6	4	4.4	minutes
Fast Charge Flat Voltage Time-out	t_{FLAT}	V_{CELL} not increasing	14.4	16	17.6	minutes
Charge Timer Accuracy			-5		+5	%
Charge Timer Range	$t_{CTMR-RANGE}$		0.5		10	h

Note 1: Voltages relative to V_{SS} .

Note 2: Specification applicable during charge cycle with $T_A = 0^\circ C$ to $+70^\circ C$.

Note 3: One time slot out of every 16 available slots gets a Cell Test.

Note 4: One time slot out of every 32 available time slots gets a charge pulse.

Note 5: 0.48 seconds is one charge time slot. A complete cycle of 4 time slots (one charge time slot per cell) is 1.92 sec.

Note 6: $V_{THM-MIN}$, $V_{THM-MAX}$, and $V_{THM-STOP}$ are fixed ratios of V_{DD} . Their ranges never overlap.

Note 7: I_{MTST} current is applied as a source current and as a sink current within 5ms after power-up.

PIN DESCRIPTION

PIN	NAME	FUNCTION
1	CC1	Charge Control 1. Turn on and off the charge PNP for Cell 1.
2	CC2	Charge Control 2. Turn on and off the charge PNP for Cell 2.
3	CC3	Charge Control 3. Turn on and off the charge PNP for Cell 3.
4	CC4	Charge Control 4. Turn on and off the charge PNP for Cell 4.
5	LED1	LED 1. Open drain output for LED. Display Cell 1 status.
6	LED2	LED 2. Open drain output for LED. Display Cell 2 status.
7	V _{SS}	Device Ground. Return current path for LEDx pins. Both VSS pins must be connected to ground.
8	LED3	LED 3. Open drain output for LED. Display Cell 3 status.
9	LED4	LED 4. Open drain output for LED. Display Cell 4 status.
10	DMSEL	Display Mode Select. Select the LED blink rate.
11	CTST	Cell Test Resistor. Cell test threshold set.
12	TMR	Timer Resistor. Charge timer set.
13	V _{DD}	Power-Supply Input. Chip supply input (4.0V to 5.5V).
14	V _{SS}	Device Ground. Internally connected to Pin 7. Both VSS pins must be connected to ground.
15	VP1	Voltage Sense 1. Positive terminal sense input for Cell 1.
16	VP2	Voltage Sense 2. Positive terminal sense input for Cell 2.
17	VP3	Voltage Sense 3. Positive terminal sense input for Cell 3.
18	VP4	Voltage Sense 4. Positive terminal sense input for Cell 4.
19	THM1	Thermister 1. Thermister input for Cell 1 and 2.
20	THM2	Thermister 2. Thermister input for Cell 3 and 4.

Figure 1. Block Diagram

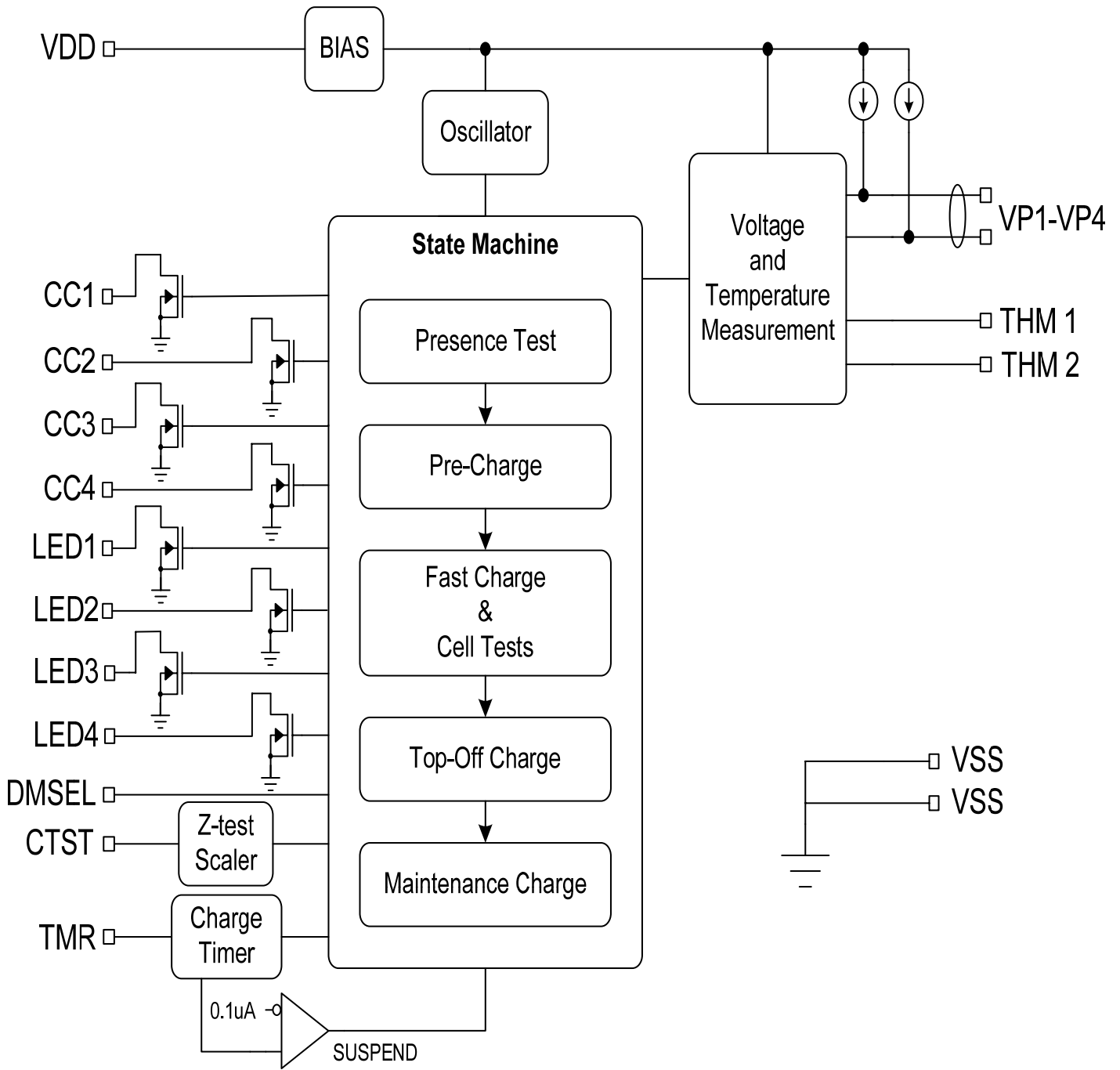

Figure 2. State Diagram

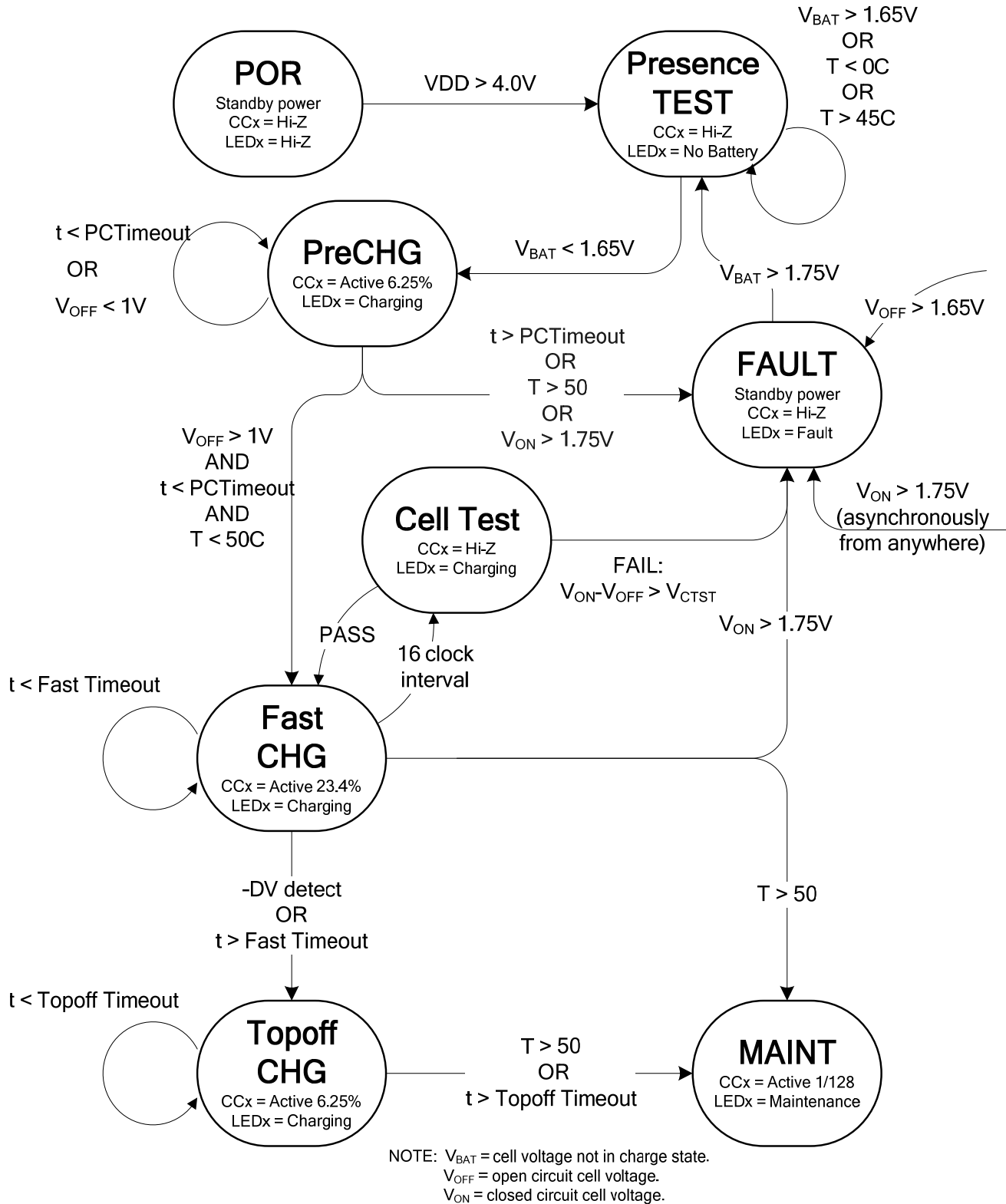
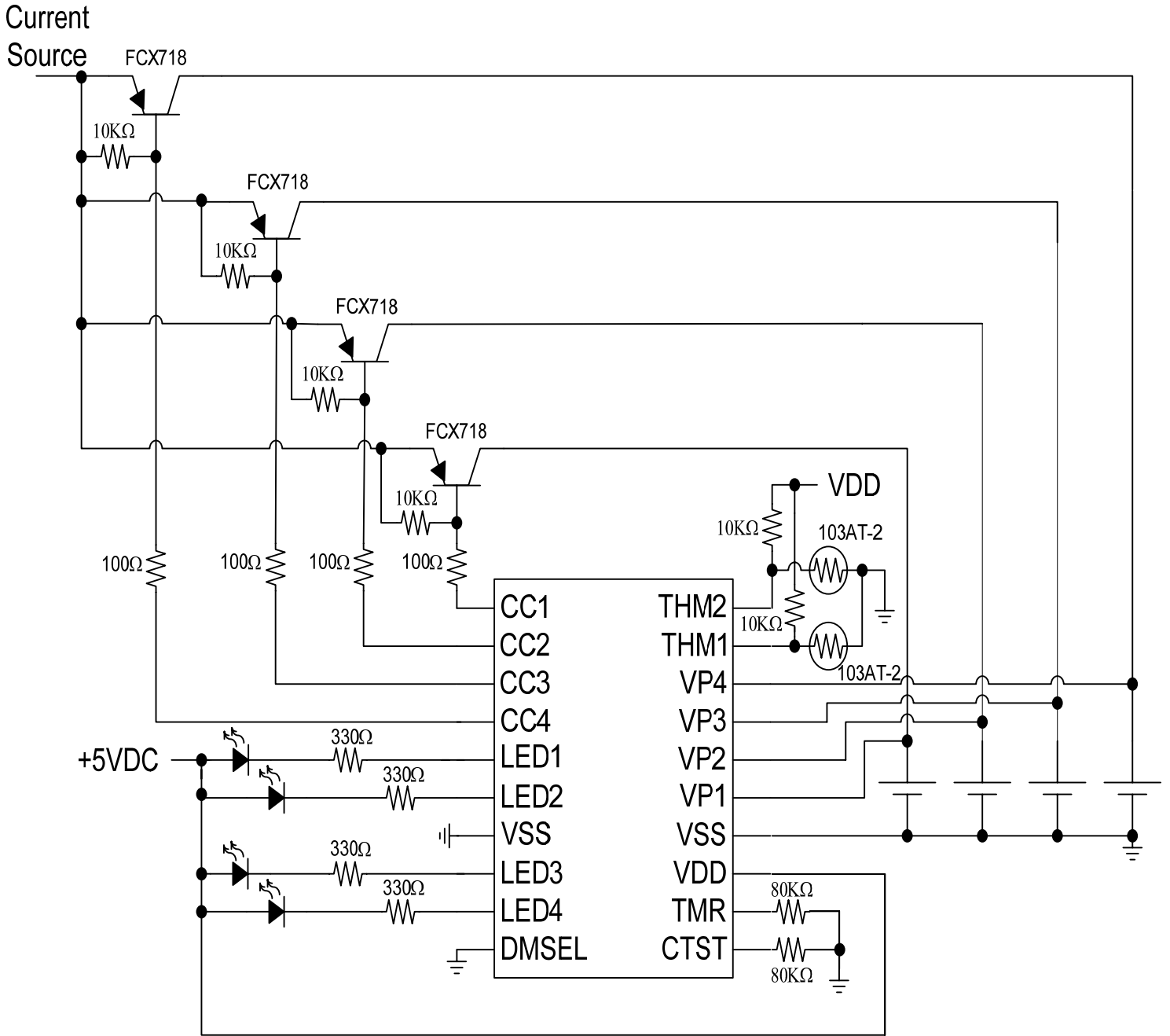

Figure 3. Application Example: Regulated Current Source Charger



DETAILED DESCRIPTION

CHARGE ALGORITHM OVERVIEW

A charge cycle begins in one of three ways: With the application of power to the DS2714 with cell(s) already inserted, with the detection of cell insertion after power-up, or when exiting suspend mode with cell(s) inserted. The charge cycle begins with Pre-charge qualification to prevent Fast charging of deeply depleted cells or charging under extreme temperature conditions. Pre-charging is performed at a reduced rate until the cell being charged reaches $V_{BAT-LOW}$ (1V). The algorithm proceeds to a Fast charge phase which includes cell tests to avoid accidental charging of alkaline cells or NiMH cells which are worn-out or damaged. Fast charging continues as long as the cell temperature is less than 50°C (based on Thermistor sensors THM 1, 2), the open circuit cell voltage(s) are between $V_{BAT-LOW}$ (1.0V) and $V_{BAT-MAX1}$ (1.65V) and the closed circuit cell voltage(s) are less than $V_{BAT-MAX2}$ (1.75V). Fast charging terminates by the $-\Delta V$ (negative delta voltage) or flat voltage method. The Top-Off charge phase follows to completely charge the cell. After the Top-off charge timer expires, the Maintenance charge phase continues indefinitely to keep the cells fully charged. Maximum voltage, temperature and charge time monitoring during all charge phases act as secondary or safety termination methods to provide additional protection from overcharge. A cell voltage greater than $V_{BAT-MAX2}$ (1.75V) will result in a fault condition, and temperature greater than 50°C (see Table 1) will result in either Fault or Maintenance depending on which charge state the device was last in. Each cell is monitored independently, and the charge phase of each cell is independently controlled. If a cell is removed while being charged, the algorithm for that cell slot is completely reset to its Presence Test state without affecting the charge control states of the other cells.

CHARGE CONFIGURATION

The DS2714 supports four slot standalone chargers. It alternates charge to the four slots every two seconds, with one half second available to each cell. Removal or insertion of a cell into the charger does not disturb the charge timing or charge rates of the other cells. Charge pulses are fed alternately to each cell under the control of the CCx pins so that the charge regimes occur in parallel. The duty cycle on the CCx pins are completely independent of one another. Transitions from Pre-charge to Fast charge, Fast charge to Top-off and Top-off to Maintenance occur independently for each cell. The configuration shown in Figure 3 is for charging four cells with a current limited source of 2A. The effective average fast charge current for each cell is $2A \times 0.25 \times 15/16 = 0.469A$. The 15/16 term is due to the fact that every 16th charge time slot is used for negative delta-voltage and impedance testing. No current is delivered to the cell during that time. Mechanical design of the holders is required to prevent insertion of more than one cell in each slot. The holder design should also prevent electrical contact with reverse polarity insertion.

PERFORMANCE REQUIREMENTS OVER TEMPERATURE AND VOLTAGE

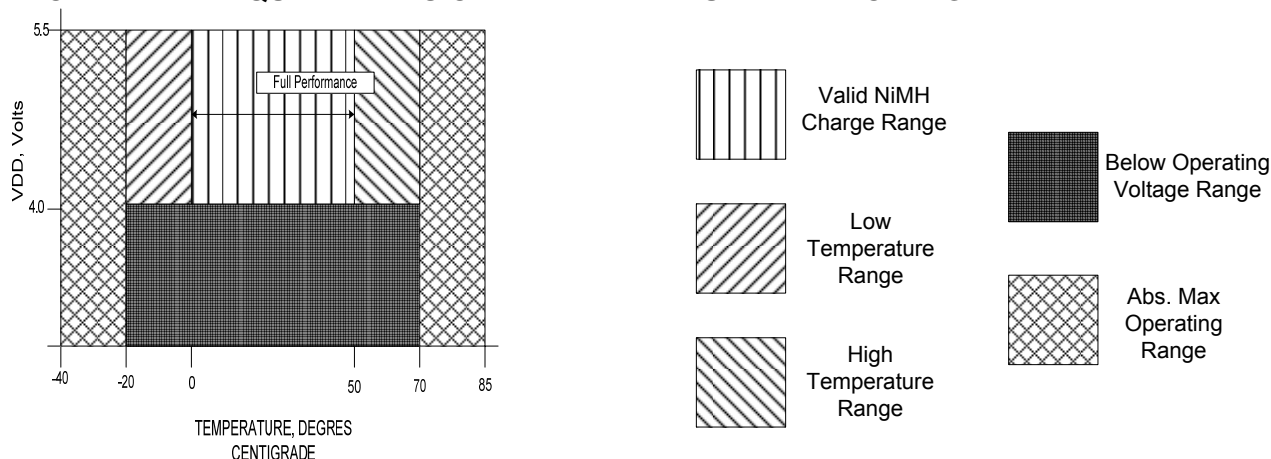

INTERNAL OSCILLATORS AND CLOCK GENERATION

An internal oscillator provides the main clock source used to generate timing signals for internal chip operation. The pre-charge timer, hold-off timers, and duty factors for the charging operations are derived from this timebase. There are two separate timers for the impedance test and Fast Charge/Topoff functions.

CHARGE TIMER

The Charge Timer monitors the duration of charge in Fast and Top-Off charge phases, and is reset at the beginning of each phase. The time-out period is set with an external resistor connected from the TMR pin to V_{SS} . Resistors can be selected to support Fast charge time-out periods of 0.5 to 10 hours and Top-off charge time-out periods of 0.25 to 5 hours. If the timer expires in Fast charge, the timer count is reset and charging proceeds to the Top-Off charge phase. The Top-Off time-out period is half of the Fast charge time-out period. When the timer expires in Top-Off, charging proceeds to the Maintenance phase. The programmed charge time approximately follows the equation:

$$t = 1.5 \cdot R / 1000 \quad (\text{time in minutes})$$

SUSPEND

Suspension of charge activity is possible by floating the TMR pin. All CCx outputs become high-Z and the Charge Timer stops. The state machine and all timers are reset to their Presence Test conditions.

TEMPERATURE SENSE

Connecting an external 10k Ω NTC thermistor between THM1 or THM2 (THMx) and V_{SS} , and a 10k Ω bias resistor between V_{DD} and THMx allows the DS2714 to sense temperature. In order to sense the temperature of the battery cells, locate the thermistor close to the body of the battery cell. The THM1 thermistor should be placed between cells 1 and 2, and THM2 thermistor between cells 3 and 4. Alternatively, the thermistors can sense ambient temperature by locating them away from the cells. THM1 and THM2 can be tied together to sense temperature using a single thermistor and bias resistor. The temperature qualification function can be defeated by tying THMx pins to a single resistor divider supplying a voltage between the Thermistor-Min and Thermistor-Max threshold voltages.

MIN, MAX TEMPERATURE COMPARE

The voltage thresholds of the THMx inputs ($V_{THM-MIN}$, $V_{THM-MAX}$) are set to allow Fast charging to start if $0^{\circ}\text{C} < T_A < 45^{\circ}\text{C}$ when using the recommended 10k Ω bias and 10k Ω thermistor. If Fast charging is in progress, and the voltage on THMx reaches $V_{THM-STOP}$ ($T_A > 50^{\circ}\text{C}$), Fast charging stops and the maintenance phase begins. In Pre-charge the device will transition to the Fault state if the voltage on THMx reaches $V_{THM-STOP}$.

Table 1. THM1, THM2 Thresholds

THM THRESHOLD	RATIO OF VDD	THERMISTOR RESISTANCE	TEMPERATURE	
			Semitec 103AT-2	Fenwal 197-103LAG-A01 173-103LAF-301
MIN	0.73	27.04k	0 $^{\circ}\text{C}$	4 $^{\circ}\text{C}$
MAX	0.33	4.925k	45 $^{\circ}\text{C}$	42 $^{\circ}\text{C}$
STOP	0.29	4.085k	50 $^{\circ}\text{C}$	47 $^{\circ}\text{C}$

CELL VOLTAGE MONITORING

Individual cell voltages are monitored for minimum and maximum values, using the $V_{BAT-LOW}$, $V_{BAT-MAX1}$ and $V_{BAT-MAX2}$ threshold limits. Upon inserting a cell or power-up with cells inserted, cell voltages must be less than the $V_{BAT-MAX1}$ threshold before charging begins. The $V_{BAT-LOW}$ threshold determines whether a Pre-charge cycle should precede the Fast charge cycle, and when to transition from Pre-charge to Fast charge. Once Fast charging commences, cell voltages are compared to the $V_{BAT-MAX2}$ threshold once every 2 seconds. The comparison occurs while the charge control pin (CC1-4) controlling current to the cell is active (low). When the charge control pin is active such that charge is applied to the cell, the cell voltage is referred to as the V_{ON} voltage. When the charge control pin is inactive, the cell voltage is referred to as the V_{OFF} voltage. Charging is halted and a Fault condition is displayed if V_{ON} is greater than $V_{BAT-MAX2}$. Charging is also halted and a fault condition is entered if V_{OFF} is greater than $V_{BAT-MAX1}$. While Fast charge is in progress, cell voltage measurements are stored and compared to future measurements for charge termination and cell test purposes.

CELL TESTS

Two types of tests are performed to detect primary Alkaline and Lithium cells or defective NiMH or NiCd secondary cells. The first test checks the absolute closed circuit cell voltage (V_{ON}), and the second test checks the difference in open circuit cell voltage (V_{OFF}) and (V_{ON}). V_{ON} for each cell is compared to the $V_{BAT-MAX2}$ threshold once every 2 seconds. During fast charge, $V_{ON} - V_{OFF}$ of each cell is compared to the cell test threshold, V_{CTST} . If $V_{ON} - V_{OFF} > V_{CTST}$, the cell test fails. Cells are tested individually so that a single improper or defective cell can be detected quickly. V_{CTST} is set by the resistance from the CTST pin to ground. The nominal sensitivity of 100mV is set by connecting an 80k Ω resistor between CTST and V_{SS} . The impedance threshold can be set from 32mV to 400mV. The following formula approximates the setting for the impedance threshold

$$V_{CTST} = 8000/R \quad (\text{value in volts})$$

- ΔV AND FLAT VOLTAGE TERMINATION

During Fast charge, $-\Delta V$ detection is performed by comparing successive voltage measurements for a drop of 2mV in the cell voltage. A Hold-off period for $-\Delta V$ detection begins at the start of Fast charging and prevents false termination in the first few minutes of the charge cycle. Once the hold-off period expires, cell voltage measurements are acquired every 16th charge time slot (approximately 31 seconds, during the CCx off time). When a newly acquired voltage measurement is greater than any previous one, the new value is retained as the maximum value. When the cell voltage no longer increases, the maximum value is retained and compared against subsequent values. If the cell voltage drops below the $-\Delta V$ threshold, $V_{-\Delta V}$, (2mV typ), Fast charging is terminated. If the cell voltage remains flat such that the maximum value persists for a period of 16 minutes (t_{FLAT}), Fast charge terminates and Top-Off charging begins.

TOP-OFF, PRE-CHARGE AND MAINTENANCE

In Top-off and Pre-charge modes, the charger scales the cell current to 1/16 of the DC current set by the current source, i.e. one charge pulse for every 16 main clock pulses, or one in four available time slots for a given cell. The ratio of average Top-off/Pre-charge current to average fast charge current is 0.286. When the charge timer expires in Top-Off, the charger enters Maintenance and delivers 1/128 of the DC charge source current to the cells (one time slot in every 32 available to that cell). This is slightly more than 3% of the average DC Fast Charge current. Maintenance charge remains continuous until power is removed, the cell(s) are removed or the DS2714 is cycled into and out of suspend mode by floating the TMR pin.

CCx OUTPUTS

The CC1 through CC4 pins operate as open-drain outputs that drive active low to connect the charge source to the NiMH cells. During charge, the behavior of these outputs depends on the charge states of the cells and on how many cells have been installed.

FAST CHARGE

Referring to the application circuit shown in Figure 3, CC1 controls the PNP switch that gates current to the cell in slot 1. CC2 controls the PNP switch that gates current to the cell in slot 2, and so on. During Fast charge, current is gated to each slot sequentially, with charge pulses occurring in alternating time frames. The cell in one slot charges while the others relax. Each cell skips a charge pulse every 16 of its allocated charge time slots (approximately once every 31 seconds) to facilitate independent testing of the open and closed circuit cell voltages (V_{OFF} and V_{ON} , respectively). Since the charge regime of each cell is independent, one cell may complete a charge phase before the other without affecting the charging of the other cells. In the case of an improper or faulty cell (ex. alkaline) being inserted along with proper cells (NiMH or NiCd), charging of the improper cell would be stopped, while the proper cells will be charged to full.

EXAMPLE TIMING DIAGRAM FOR THE DS2714

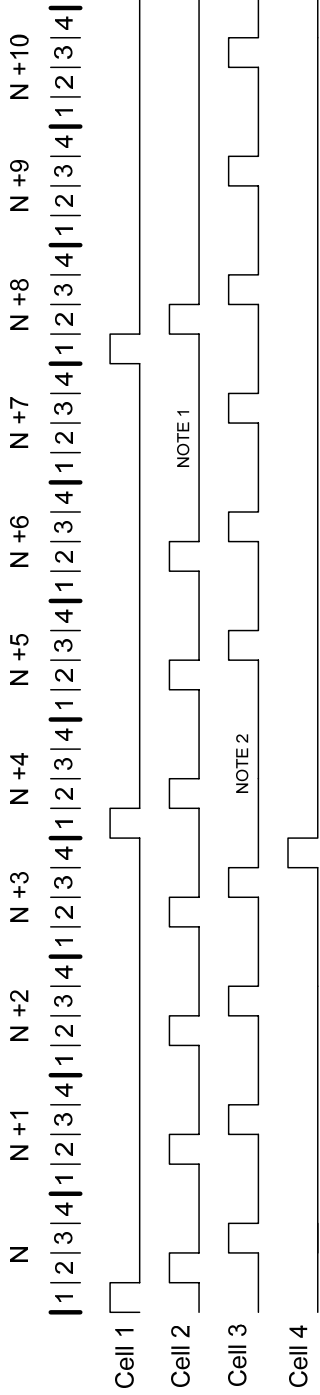

Note 1: Cell test time slot for Cell 2.

Note 2: Cell test time slot for Cell 3.

In this timing diagram, the pulses represent charge current into the individual cells. Cell 1 is in Precharge (the timing of Precharge gets one charge pulse out of every four available time slots).

Cell 2 is in initially in Fast Charge and it transitions to Topoff charge during the N+7th time interval (Note 1) shown in the diagram.

Cell 3 is in Fast charge. Cell testing is performed during the interval marked Note 2. This cell is not ready to go into Top-off and it

Cell 4 is in maintenance mode, one out of every 32 available time slots gets a charge pulse.

LEDx OUTPUTS, DISPLAY MODE SELECT

Open-drain outputs LEDx pull low to indicate charge status. When inactive, the outputs are high impedance. LED1 displays the status for the cell monitored by VP1, LED2 displays the status for the cell monitored by VP2 and so on. The LED pins drive low in three “blink” patterns to annunciate the charge status. Table 2 summarizes the LED operation in each display mode (DM0, DM1, DM2) for each charge condition.

Table 2. Display Patterns By Display Mode and Charge Activity

Display Mode		Charge Activity			
	DMSEL pin	No Battery	Pre/Fast/Top-off Charging	Maintenance	Fault
DM0	Low	Hi-Z	Low	0.80s Low 0.16s Hi-Z	0.48s Low 0.48s Hi-Z
DM1	Float	Hi-Z	Low	Hi-Z	0.16s Low 0.16s Hi-Z
DM2	High	Hi-Z	0.80s Low 0.16s Hi-Z	Low	0.16s Low 0.16s Hi-Z

PACKAGE INFORMATION

(The package drawing(s) in this data sheet may not reflect the most current specifications. For the latest package outline information, go to www.maxim-ic.com/DallasPackInfo.)

Maxim/Dallas Semiconductor cannot assume responsibility for use of any circuitry other than circuitry entirely embodied in a Maxim/Dallas Semiconductor product. No circuit patent licenses are implied. Maxim/Dallas Semiconductor reserves the right to change the circuitry and specifications without notice at any time.

Maxim Integrated Products, 120 San Gabriel Drive, Sunnyvale, CA 94086 408-737-7600

© 2006 Maxim Integrated Products • Printed USA

The Maxim logo is a registered trademark of Maxim Integrated Products, Inc. The Dallas logo is a registered trademark of Dallas Semiconductor Corporation.

Looking for pricing, stock, or lifecycle information?

Click below to explore more details on WIN SOURCE:

 [View DS2714E+ on WIN SOURCE](#)

 [Maxim Integrated Information](#)

Optimize Your Supply Chain with WIN SOURCE Solutions

-  Global Sourcing Solution
-  Obsolete Management
-  Cost Control Management
-  Shortage Management
-  Alternative Solution
-  Excess Inventory Management