



**THE DATASHEET OF  
DS2715Z+**



# DS2715

## NiMH Battery Pack Charge Controller

### DESCRIPTION

The DS2715 is well suited for cost-sensitive charger applications where the battery pack is either internal or external to the application. It has been optimized for safe and reliable charging of 1 to 10 NiMH cells in series. The internal gain block can be selected as either a comparator or transconductance amplifier for charge current regulation. This makes the DS2715 configurable as a switched DC charger, a linear current regulator, or a switchmode current source. The DS2715 pre-conditions severely depleted cells before entering full charge mode. It terminates full charge using the dT/dt technique, which requires an external sensing thermistor. Over-temperature, under-temperature, and over-voltage detection prevents charging under unsafe conditions. A user selectable charge timer allows charge rates from 0.167C to 2C. FAST-CHARGE, TOPOFF and DONE modes are included for highly reliable, safe charging of NiMH cells. Discharge mode allows the DS2715 to enter a low power sleep state while the cell pack is being discharged.

### FEATURES

- Charges 1 to 10 NiMH Cells
- FAST-CHARGE at up to a 2C Rate
- PRECHARGE and TOPOFF Charge Modes Help Cell Conditioning
- Load Detection Allows the DS2715 to Enter Low Power Sleep Mode (Less than 10 $\mu$ A) while the Cell Pack is Discharged
- dT/dt Charge Termination Eliminates Cell Charge Stress
- Monitors Voltage, Temperature, and Time for Safety and Secondary Termination
- Regulates Current through Either Linear Control or Switch-Mode Control
- LED Output Displays Charge State
- Small 16-Pin SO Package

### APPLICATIONS

Portable DVD Players  
 Portable Television Sets  
 Handheld Gaming  
 Test Equipment  
 Handheld POS Terminals

### PIN CONFIGURATION

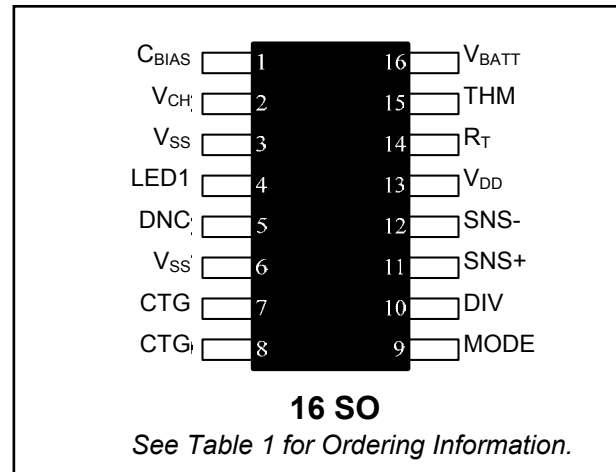
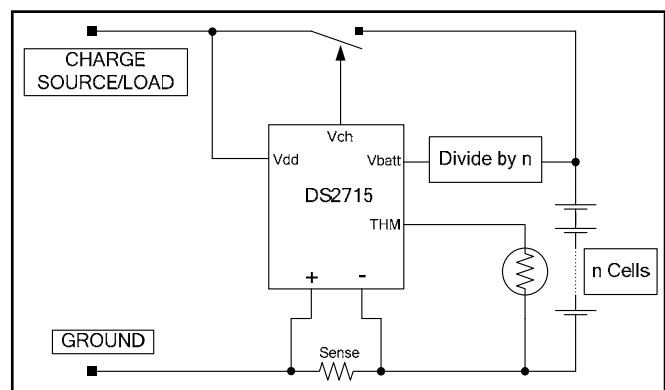

**Table 1. ORDERING INFORMATION**

| PART         | MARKING | PIN-PACKAGE |
|--------------|---------|-------------|
| DS2715Z+     | D2715   | 16 SO       |
| DS2715Z+T&R  | D2715   | 16 SO       |
| DS2715BZ+    | D2715B  | 16 SO       |
| DS2715BZ+T&R | D2715B  | 16 SO       |

+ Denotes a lead(Pb)-free/RoHS-compliant package.  
 T&R = Tape and reel.

### OPERATIONAL DIAGRAM



**ABSOLUTE MAXIMUM RATINGS\***

|   |                             |
|---|-----------------------------|
| Voltage on V <sub>DD</sub> and V <sub>CH</sub> Pins with Respect to V <sub>SS</sub> | -0.3V to +18V               |
| Voltage on LED1 Pin   | -0.3V to +18V               |
| Voltage on SNS-   | -0.3V to +0.3V              |
| Voltage on C <sub>BIAS</sub>  | -0.3V to 6V                 |
| Voltage on all Other Pins   | -0.3V to V <sub>Cbias</sub> |
| Continuous Sink Current V <sub>CH</sub> and LED1                                    | 28mA                        |
| Operating Temperature Range   | -20°C to +85°C              |
| Storage Temperature Range   | -55°C to +125°C             |
| Soldering Temperature   | See IPC/JEDEC J-STD-020     |
| Human Body Model (HBM) ESD Limit of V <sub>CH</sub> Pin                             | 500V                        |
| HBM ESD Limit of all Other Pins   | 2KV                         |

\*This is a stress rating only and functional operation of the device at these or any other conditions above those indicated in the operation sections of this specification is not implied. Exposure to absolute maximum rating conditions for extended periods of time may affect reliability.

**RECOMMENDED DC OPERATING CONDITIONS**(4.5V ≤ V<sub>DD</sub> ≤ 16.5V; T<sub>A</sub> = 0°C to +70°C.)

| PARAMETER                         | SYMBOL             | CONDITIONS | MIN | TYP | MAX                | UNITS |
|-----------------------------------|--------------------|------------|-----|-----|--------------------|-------|
| Supply Voltage                    | V <sub>DD</sub>    | (Note 1)   | 4.5 |     | 16.5               | V     |
| LED1 Voltage                      | V <sub>LED</sub>   | (Note 1)   | 0.0 |     | 16.5               | V     |
| Mode Voltage                      | V <sub>MODE</sub>  | (Note 1)   | 0.0 |     | V <sub>Cbias</sub> | V     |
| V <sub>CH</sub> Voltage           | V <sub>VCH</sub>   | (Note 1)   | 0.0 |     | 16.5               | V     |
| C <sub>BIAS</sub> Capacitor Range | C <sub>Cbias</sub> |            | .02 |     | .15                | μF    |
| R <sub>T</sub> Resistor Range     | R <sub>Rt</sub>    |            | 20  |     | 240                | KΩ    |

**DC ELECTRICAL CHARACTERISTICS**(4.5V ≤ V<sub>DD</sub> ≤ 16.5V, T<sub>A</sub> = 0°C to +70°C, unless otherwise noted.)

| PARAMETER                               | SYMBOL                 | CONDITIONS                               | MIN | TYP  | MAX | UNITS           |
|---|------------------------|--|-----|------|-----|-----------------|
| Operating Current (Note 2)              | I <sub>DDA</sub>       | Linear Mode, V <sub>DD</sub> = 16.5V     |     | 1.3  | 1.6 | mA              |
|   |                        | Comparator Mode, V <sub>DD</sub> = 16.5V |     | 150  | 250 | μA              |
| Idle Current                            | I <sub>DDS</sub>       | V <sub>DD</sub> < V <sub>UVLO</sub>      |     |      | 10  | μA              |
| Discharge Current                       | I <sub>DDD</sub>       | Discharge latch set (Note 2)             |     |      | 200 | μA              |
| UVLO Threshold                          | V <sub>UVLO</sub>      | V <sub>DD</sub> Rising (Note 3)          | 3.8 | 3.9  | 4.0 | V               |
| UVLO Hysteresis                         | V <sub>UVLO-HYS</sub>  | V <sub>DD</sub> Falling                  |     | 35   |     | mV              |
| V <sub>CH</sub> Sink Current            | I <sub>OL-Vch</sub>    | V <sub>OL</sub> = 1.5V                   | 20  |      |     | mA              |
| LED1 Sink Current                       | I <sub>OL-LED</sub>    | V <sub>OL</sub> = 1.0V                   | 20  |      |     | mA              |
| Leakage Current, V <sub>CH</sub> , LED1 | I <sub>LKG</sub>       | Pin Inactive or Device Idle              | -1  |      | +1  | μA              |
| THM Pin Leakage Current                 | I <sub>LKG-THM</sub>   |  | -1  |      | +1  | μA              |
| V <sub>BATT</sub> Pin Leakage Current   | I <sub>LKG-Vbatt</sub> |  | -50 |      | +50 | nA              |
| C <sub>BIAS</sub> Voltage               | V <sub>Cbias</sub>     | 0 < I <sub>Cbias</sub> < 0.4mA           | 3.9 | 4.0  | 4.3 | V               |
| DIV Pin Load Current                    | I <sub>Div</sub>       |  |     |      | 500 | uA              |
| Current Sense Amplifier Gain            | G <sub>ERR</sub>       | 100μA < I <sub>Vch</sub> < 20mA          | 5   | 6.25 | 7.5 | Ω <sup>-1</sup> |

| PARAMETER                     | SYMBOL     | CONDITIONS | MIN | TYP | MAX | UNITS         |
|-------------------------------|------------|------------|-----|-----|-----|---------------|
| Current Sense Comparator Gain | $G_{COMP}$ | (Note 7)   | 10  |     |     | $\Omega^{-1}$ |

## AC ELECTRICAL CHARACTERISTICS

( $4.5V \leq V_{DD} \leq 16.5V$ ,  $T_A = 0^\circ C$  to  $+70^\circ C$ , unless otherwise noted.)

| PARAMETER   | SYMBOL     | CONDITIONS                         | MIN | TYP | MAX | UNITS   |
|---|------------|------------------------------------|-----|-----|-----|---------|
| UVLO Debounce Time                                    | $t_{UVLO}$ |                                    | 10  |     |     | $\mu s$ |
| Current Sense Comparator Propagation Delay            | $t_{COMP}$ | (Note 7)                           |     |     | 250 | ns      |
| Discharge Detect Propagation Delay                    | $t_{DD}$   | From detection of current reversal |     |     | 1   | $\mu s$ |
| Return To Normal Function (Op-Amp or Comparator Mode) | $t_{RNF}$  | Time from reset of discharge latch |     |     | 1   | $\mu s$ |
| $R_T$ Timing Accuracy                                 | $t_{Rt}$   | (Note 4)                           | -10 |     | +10 | %       |
| Internal Clock Accuracy                               | $t_{BASE}$ |                                    | -10 |     | +10 | %       |

## ELECTRICAL CHARACTERISTICS: CHARGING

( $4.5V \leq V_{DD} \leq 16.5V$ ,  $T_A = 0^\circ C$  to  $+70^\circ C$ , unless otherwise noted.)

| PARAMETER                                  | SYMBOL         | CONDITIONS                             | MIN   | TYP  | MAX   | UNITS          |
|--|----------------|--|-------|------|-------|----------------|
| FAST-CHARGE Comparator Threshold           | $V_{FC}$       | FAST-CHARGE                            | -127  | -121 | -115  | mV             |
| FAST-CHARGE Comparator Hysteresis          | $V_{HYS-FC}$   | FAST-CHARGE                            | 31    | 28   | 25    | mV             |
| TOPOFF and PRECHARGE Comparator Threshold  | $V_{TO}$       | TOPOFF and PRECHARGE                   | -38   | -33  | -28   | mV             |
| TOPOFF and PRECHARGE Comparator Hysteresis | $V_{HYS-TO}$   | TOPOFF and PRECHARGE                   | 10    | 8    | 6     | mV             |
| Discharge Latch Reset Threshold            | $V_{DCHG-RST}$ |  | -15   | -10  | -5    | mV             |
| Discharge Latch Set Threshold              | $V_{DCHG-SET}$ | Reverse current through sense resistor | 5     | 10   | 15    | mV             |
| Low Battery Detect Threshold               | $V_{LB}$       | From presence detect into PRECHARGE    | 0.95  | 1.0  | 1.05  | V              |
| Cell Detect Threshold                      | $V_{DET}$      |  | 1.50  | 1.55 | 1.60  | V              |
| No Cell Detect Threshold                   | $V_{OPEN}$     |  | 1.60  | 1.65 | 1.70  | V              |
| Presence Detect Threshold Hysteresis       | $V_{HYS-PD}$   |  | 90    | 100  | 110   | mV             |
| Minimum Charge Temp                        | $V_{THM-MIN}$  | (Note 5, 6)                            | 2.88  | 2.92 | 2.96  | V              |
|  |                |  |       | 0    |       | $^\circ C$     |
| Maximum Charge Temp                        | $V_{THM-MAX}$  | (Note 5, 6)                            | 1.28  | 1.32 | 1.36  | V              |
|  |                |  |       | 45   |       | $^\circ C$     |
| Over Temp                                  | $V_{THM-STOP}$ | (Note 5, 6)                            | 1.12  | 1.16 | 1.20  | V              |
|  |                |  |       | 50   |       | $^\circ C$     |
| dT/dt Detect                               | $T_{TERM}$     |  | 0.425 | 0.5  | 0.575 | $^\circ C/min$ |

| PARAMETER                            | SYMBOL             | CONDITIONS | MIN  | TYP | MAX  | UNITS |
|--------------------------------------|--------------------|------------|------|-----|------|-------|
| dT/dt Blanking Time                  | $t_{\text{BLANK}}$ |            | 3.85 | 4.3 | 4.75 | Min   |
| PRECHARGE Timeout                    | $t_{\text{PC-TO}}$ |            |      | 30  |      | Min   |
| FAST-CHARGE Timer Range              | $t_{\text{FC}}$    |            | 0.5  |     | 6    | Hours |
| TOPOFF to FAST-CHARGE Duration Ratio |                    | DS2715     |      | 1:2 |      |       |
|                                      |                    | DS2715B    |      | 1:4 |      |       |

- Note 1:** Voltages relative to  $V_{\text{SS}}$ .
- Note 2:** Does not include current through  $V_{\text{CH}}$ ,  $R_{\text{T}}$ , and DIV pins.
- Note 3:** Below this voltage no I/O pins are active.
- Note 4:** Does not include tolerance of  $R_{\text{T}}$  resistor.
- Note 5:**  $V_{\text{BIAS}}$  and resistor tolerances must be added to determine actual threshold.
- Note 6:** Specified temperature thresholds are only valid if recommended thermistor types are used.
- Note 7:** Specification is guaranteed by design.

## DETAILED PIN DESCRIPTION

| PIN | NAME              | DESCRIPTION  |
|-----|-------------------|--|
| 1   | $C_{\text{BIAS}}$ | Bypass for Internal Voltage Regulator  |
| 2   | $V_{\text{CH}}$   | Cell Stack Charge Control Output   |
| 3   | $V_{\text{SS}}$   | Chip Supply Return and Local Ground Reference  |
| 4   | LED1              | Charging Indicator Output  |
| 5   | DNC               | Do Not Connect   |
| 6   | $V_{\text{SS}}$   | Chip Supply Return and Local Ground Reference  |
| 7   | CTG               | Connect to Local Ground ( $V_{\text{SS}}$ )  |
| 8   | CTG               | Connect to Local Ground ( $V_{\text{SS}}$ )  |
| 9   | MODE              | Mode Select. Connect to $V_{\text{SS}}$ for linear mode of operation or $C_{\text{BIAS}}$ for comparator mode of operation.            |
| 10  | DIV               | Thermistor Divider. Stable output to form a resistor divider for measuring temperature on THM  |
| 11  | SNS+              | Positive Current Sense. Connect to the charge source side of the sense resistor  |
| 12  | SNS-              | Negative Current Sense. Connect to the cell stack side of the sense resistor   |
| 13  | $V_{\text{DD}}$   | Chip Supply Input: +4.5V to +16.5V range   |
| 14  | $R_{\text{T}}$    | Failsafe Timeout. Timeout is selected by an external resistor from $R_{\text{T}}$ to $V_{\text{SS}}$                                   |
| 15  | THM               | Thermistor Input. Connect to a thermistor located in the cell pack and a divider resistor from the Div pin                             |
| 16  | $V_{\text{BATT}}$ | Battery Voltage Sense Input. Connect to a divider from the positive terminal of the cell stack to measure the voltage of a single cell |

Figure 1. BLOCK DIAGRAM

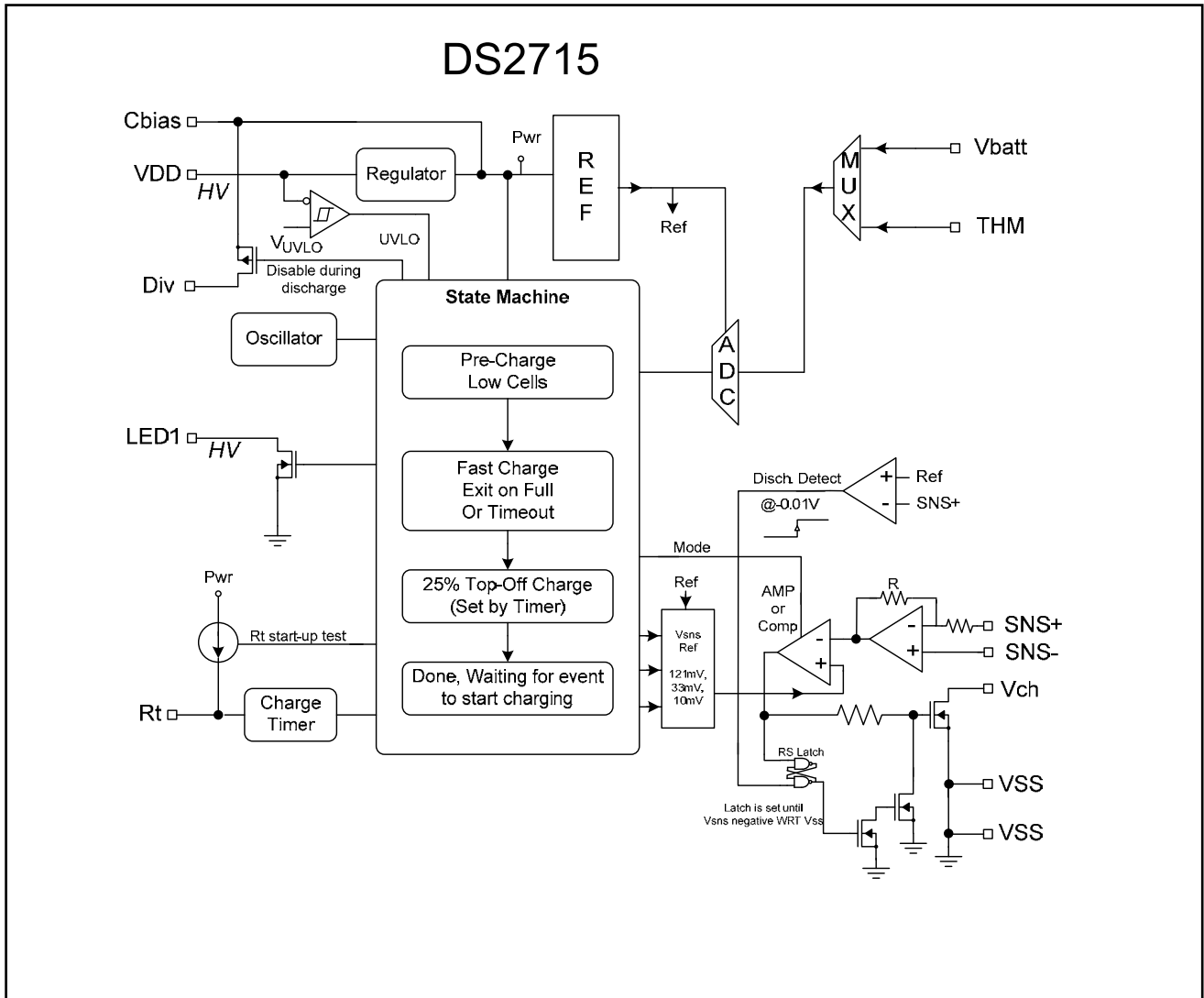



## DETAILED DESCRIPTION

### Charge Cycle Overview

The DS2715 regulates the charge of up to 10 NiMH cells in a series configuration. With the mode select pin, the DS2715 can be configured to regulate either as an error amplifier in linear mode or as a comparator in switched mode. A charge cycle begins in one of two ways: with the application of power to the DS2715 while the cell pack is already inserted, or with the detection of cell insertion after power-up.

After cell presence confirmation, PRECHARGE qualification occurs to prevent fast charging of deeply depleted cells or charging under extreme temperature conditions. Pre-charging is performed at a reduced rate of approximately  $\frac{1}{4}$  the FAST-CHARGE current until each cell reaches 1V. The algorithm then proceeds to the FAST-CHARGE phase. Fast charging continues as long as the cell pack temperature is less than 50°C based on the THM voltage, and the cell voltage as measured at the  $V_{\text{BATT}}$  pin in the middle of the resistor divider remains below 1.65V, indicating the cell pack is still present. Fast charging terminates normally by measuring the cell pack's thermal rate of change,  $dT/dt$ . When the cell pack's thermal rate of change exceeds 0.5°C per minute, the DS2715 enters TOPOFF. The DS2715 has an internal charge timer as secondary overcharge protection if the charge is not terminated properly by the  $dT/dt$  method. The charge termination timer duration is user selectable from 30 minutes up to 6 hours by an external resistor on the  $R_T$  pin.

Following a normally terminated or timed-out FAST-CHARGE phase, the DS2715 enters TOPOFF. It remains in this state for one-half (one-quarter for DS2715B) of the period of the FAST-CHARGE timeout as selected by the external resistor on  $R_T$ . After the TOPOFF charge timer expires, the DONE phase continues indefinitely until the cell pack is removed from the charger or DISCHARGE mode is entered. For the standard application circuit configuration, when a load drawing at least  $V_{\text{dchg-set}}$  across the sense resistor is attached to the cell pack, the DS2715 switches to DISCHARGE mode. All charge functions are disabled and the regulation FET is driven on to allow the cell pack to discharge. Throughout the charging process, the open-drain LED1 output indicates the charge status to the user.

### Undervoltage Lockout (Reset)

The UVLO circuit serves as a power-up and brownout detector by monitoring  $V_{\text{DD}}$  to prevent charging until  $V_{\text{DD}}$  rises above  $V_{\text{UVLO}}$ , or when  $V_{\text{DD}}$  drops below  $V_{\text{UVLO}} - V_{\text{UVLO-HYS}}$ . If UVLO is active, charging is prevented, the state machine is forced to the RESET state, and all charge timers are reset. A 10 $\mu$ s deglitch circuit provides noise immunity. Once  $V_{\text{DD}}$  reaches an acceptable operating voltage, the DS2715 enters the PRESENCE state.

## PRESENCE

The DS2715 enters the PRESENCE state whenever  $V_{DD} > V_{UVLO}$  and  $V_{BATT} > V_{OPEN}$  indicating that the charge source is present, but no cell is available to charge. The DS2715 will remain in the PRESENCE state until a cell is inserted into the circuit causing the voltage on  $V_{BATT}$  to fall below 1.55V ( $V_{DET}$ ) and the cell temperature is inside a valid charging range between 0°C and 45°C ( $T_{THM-MIN}$  and  $T_{THM-MAX}$  when used with recommended thermistor and resistor values). If both of these conditions are met, the DS2715 will enter PRE-CHARGE. If cells are inserted, but the temperature is outside the valid charging range, the DS2715 will remain in the PRESENCE state until the cell temperature falls within the valid charging range.

## PRE-CHARGE

The DS2715 enters the PRECHARGE state when a valid cell voltage is applied to  $V_{BATT}$  and the cell temperature as measured by the DS2715 thermistor circuit is within the valid charging range. PRE-CHARGE mode has a 4 second filter to suppress noise on  $V_{BATT}$  caused by cell insertion that may cause a premature return to PRESENCE state. The DS2715 precharges the cell by regulating the voltage drop across the sense resistor to -33mV ( $V_{TO}$ ) in linear mode or -29mV ( $V_{TO} + 0.5 \times V_{HYS-TO}$ ) in comparator mode. The polarity of the voltage drop across the sense resistor is referenced to the polarity relationship indicated by the SNS+ and SNS- pins on the device. Precharging will last until the cell voltage measured by  $V_{BATT}$  exceeds 1.0V ( $V_{BATT} > V_{LB}$ ), at which time the DS2715 will enter the FAST-CHARGE state. If the cell voltage does not exceed  $V_{LB}$  within 30 minutes or if the cell temperature exceeds 50°C at any time during PRECHARGE, the DS2715 enters the FAULT state. If at any time during PRECHARGE the voltage on  $V_{BATT}$  exceeds 1.65V ( $V_{OPEN}$ ), the DS2715 determines that the cell pack has been removed and returns to the PRESENCE state.

## FAST-CHARGE

In FAST-CHARGE mode, the DS2715 regulates the voltage across the sense resistor to -121mV ( $V_{FC}$ ) in linear mode or about -107mV ( $V_{FC} + 0.5 \times V_{HYS-FC}$ ) in comparator mode. LED1 indicates the cell pack is being charged. During FAST-CHARGE, the DS2715 constantly measures the rate of change of the cell temperature (dT/dt). When the cell pack's dT/dt exceeds 0.5°C per minute ( $T_{TERM}$ ) the DS2715 enters the TOPOFF state. The DS2715 ignores changes in the cell temperature caused by charge initiation for the first 4.3 minutes ( $t_{BLANK}$ ). As secondary overcharge protection, the DS2715 will terminate FAST-CHARGE and enter TOPOFF based on a time delay set by the external resistor on the  $R_T$  pin. This resistor value can set the secondary charge termination delay to anywhere from 30 minutes up to 6 hours. If the cell temperature exceeds 50°C at any time during FAST-CHARGE, the DS2715 enters the DONE state. If at any time during FAST-CHARGE the voltage on  $V_{BATT}$  exceeds 1.65V ( $V_{OPEN}$ ), the DS2715 determines that the cell pack has been removed and returns to the PRESENCE state.

## TOPOFF

In TOPOFF mode, the DS2715 regulates the voltage across the sense resistor to -33mV ( $V_{TO}$ ) in linear mode or -29mV ( $V_{TO} + 0.5 \times V_{HYS-TO}$ ) in comparator mode. LED1 indicates the cell pack is being charged. The charge timer is reset and restarted with a time-out period of one-half (one-quarter for DS2715B) the fast-charge duration. When the charge timer expires or if the measured temperature exceeds 50°C, the charger enters the DONE state.

## DONE/Maintenance

The DS2715 enters the DONE state whenever the charge completes normally or if the measured cell temperature exceeds 50°C during the charge. While in the done state  $V_{CH}$  is driven to high impedance to prevent further regulated charging of the cell pack and LED is driven high-impedance to indicate no charging is taking place. A maintenance charge can be applied to the cells by providing a one-way resistive path from the charge source to the cell pack bypassing the regulating transistor. See the example in the circuit of Figure 3. The DS2715 remains in the DONE state until a cell voltage greater than 1.65V ( $V_{OPEN}$ ) is detected on  $V_{BATT}$  indicating cell pack removal, the  $R_t$  pin is floated (see SUSPEND function), or DISCHARGE mode is entered.

## FAULT

The DS2715 enters FAULT if PRECHARGE is unable to charge the cell above 1.0V ( $V_{LB}$ ) before the 30 minute PRECHARGE timeout ( $t_{PC-TO}$ ) or if the cell temperature exceeds 50°C during PRECHARGE. In the fault state,  $V_{CH}$  is high impedance and LED1 output pulses to indicate the fault condition. The DS2715 remains in FAULT until a cell voltage greater than 1.65V ( $V_{OPEN}$ ) is detected on  $V_{BATT}$  indicating the cell pack has been removed. The DS2715 then enters the PRESENCE state and waits for the next cell insertion.

## SUSPEND

Suspension of charge activity is possible by floating the  $R_T$  pin. The state machine and all timers are reset to their presence test conditions when suspending from a charge mode. The DISCHARGE mode is not affected by the SUSPEND function. The  $V_{CH}$  output is high-impedance for charging modes, and operates as normal for DISCHARGE mode during SUSPEND. The SUSPEND function is useful for resetting the DS2715 in applications where the batteries are not removed from the circuit and DISCHARGE mode is not utilized. It also allows for a means to stop charging by the application circuit, such as with a microcontroller signal for example.

## DISCHARGE Mode

When the DS2715 detects a discharge current voltage drop of  $V_{DCHG-SET}$  or greater across the sense resistor, charging is terminated and the DS2715 enters the DISCHARGE state. Initially, the discharge current must flow through the parasitic diode of the PFET regulating transistor until the DS2715 switches to DISCHARGE mode. While in this mode, voltage sensing, thermal sensing, and the LED1 output are disabled. The  $V_{CH}$  pin is driven low to fully bias the charge control transistor into a low impedance state and allow the pack to be discharged. Current drain of the DS2715 drops to  $I_{DD}$ . The DS2715 remains in DISCHARGE mode until a charge current across the sense resistor causes a sense voltage of at least  $V_{DCHG-RST}$  or the device is power cycled. When either of these events occur, the DS2715 enters the PRESENCE state to begin a new charge cycle.

## LED1 Output

Open-drain output LED1 pulls low to indicate charge status. When inactive, the output is high impedance. LED1 displays the state of charge and the charge results. The LED1 pin drives low in a 1Hz, 50% duty cycle “blink” pattern to indicate cells are charging. LED1 blinks at 4Hz, 50% duty cycle to signal a charging fault has occurred. The LED1 pin remains in a high-impedance state when no cells are present or the discharge latch is set. Table 2 summarizes the LED operation for each charge condition.

**Table 2. LED DISPLAY PATTERNS BASED ON CHARGE STATE**

|      | CHARGE STATE |                               |        |                               |                |
|------|--------------|-------------------------------|--------|-------------------------------|----------------|
|      | NO BATTERY   | CHARGING                      | DONE   | FAULT                         | DISCHARGE MODE |
| LED1 | High-Z       | Blinks at 1HZ, 50% duty cycle | High-Z | Blinks at 4Hz, 50% duty cycle | High-Z         |

*High-Z = High Impedance*

## CURRENT REGULATION

Three basic modes of charging operation are supported by the DS2715: Offline switching through an optocoupler, linear regulation, and DC input switched mode. The offline switching method requires a voltage clamp on the regulated output. Mode of operation is selected through the Mode pin. Connecting the Mode pin to  $V_{SS}$  configures the analog block as a transconductance amplifier for linear mode of operation. Connecting the Mode pin to the Cbias pin configures the DS2715 as a comparator for switched mode of operation.

### Current-Sense Amplifier Mode

An error amplifier block provides several options to regulate the charge current. The 20mA open-drain output  $V_{CH}$  can drive a PMOS or PNP pass element for linear regulation, or the output can drive an optocoupler for isolated feedback to a primary-side PWM controller. PMOS is the preferred device type when the pass element will also be used as a discharge path to the load. This is because sufficient transconductance with both polarities of drain current is easily realized compared to the difficulty in achieving this with BJT types. The SNS- pin is a remote-sense return and should be connected to the battery ground side of the sense resistor using a separate isolated conductor. During FAST-CHARGE, an error signal between the current-sense signal (across the sense resistor) and the internal reference is produced so the voltage across the sense resistor is maintained at  $V_{FC}$  in a closed-loop circuit. During PRECHARGE and TOPOFF, the voltage across the sense resistor is maintained at  $V_{TO}$ .

### Current-Sense Comparator Mode

The comparator in the DS2715 switches the open drain  $V_{CH}$  pin between ON and OFF when the sense resistor voltage reaches high and low thresholds. The  $V_{CH}$  output is capable of driving a PNP bipolar or a PMOS transistor, enabling the use of a switch-mode power stage. PMOS is again preferred when the pass element will also be used

as a discharge path to the load. Hysteresis on the comparator input provides the difference between the ON and OFF state thresholds. In a closed-loop regulation circuit, the comparator regulates voltage across the sense resistor as referenced to the SNS pins to a DC average of:

$$V_{\text{SNS}} = V_{\text{FC}} + 0.5 \times V_{\text{HYS-FC}} = -0.107\text{V during FAST-CHARGE}$$

$$V_{\text{SNS}} = V_{\text{TO}} + 0.5 \times V_{\text{HYS-TO}} = -0.029\text{V during TOPOFF}$$

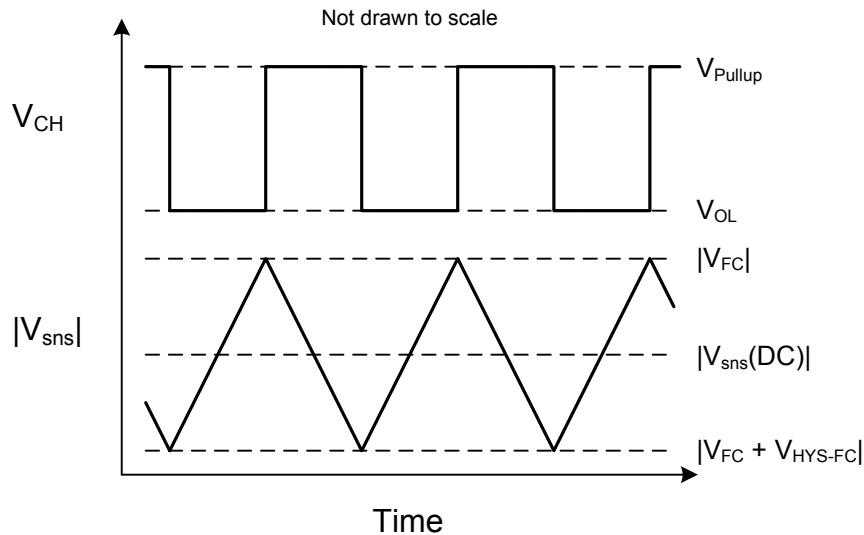
**Figure 3. Ideal Comparator Input and Charge Control Output Waveforms****Charge Rate Selection**

The charge rate is determined by an external sense resistor connected between the SNS+ and SNS- pins. The DS2715 will regulate the charge current to maintain a voltage drop of  $V_{FC}$  (or  $V_{FC} + 0.5 \times V_{HYS-FC}$  in comparator mode) across the sense resistor during FAST-CHARGE. The sense resistor can therefore be selected by:

Linear Mode:  $R = |V_{FC} / \text{Desired FAST-CHARGE Current}|$

Comparator Mode:  $R = |(V_{FC} + 0.5 \times V_{HYS-FC}) / \text{Desired FAST-CHARGE Current}|$

**Timeout Selection**

The various charge modes employ different timers to ensure reliable and safe charging. PRECHARGE has a fixed 30 minute limit generated by an internal oscillator. A fault is generated if this time limit is exceeded. FAST-CHARGE mode normally operates until its dT/dt termination scheme activates. In the event that the dT/dt sensing does not perform correctly, a safety timeout is required. This timeout is set by an external resistor on the Rt pin to  $V_{SS}$  and provides secondary protection against significant overcharging. As such, the value of the Rt resistor should be chosen so that the timeout is greater than the FAST-CHARGE time expected in the application, but not so much greater that its protection is compromised. If the timer expires during FAST-CHARGE, the timer count is reset and charging proceeds to the TOPOFF charge phase. The Rt resistor also sets the timed charge duration of TOPOFF mode. The TOPOFF time-out period is fixed at half (a quarter for the DS2715B) of the FAST-CHARGE time-out period. When the timer expires in TOPOFF, the DS2715 enters the DONE state.

Resistors can be selected to support fast-charge time-out periods of 0.5 to 6 hours and TOPOFF charge time-out periods of 0.25 to 3 hours (0.125 to 1.5 hours for the DS2715B). The programmed FAST-CHARGE time approximately follows the equation:

$$t(\text{minutes}) = 1.5 \times R(\text{ohms}) / 1000$$

## TEMPERATURE SENSE

Accurate temperature sensing is needed to determine end of charge by  $dT/dt$  and to detect over temperature fault conditions. Connecting an external  $10k\Omega$  NTC thermistor between THM and  $V_{SS}$ , and a  $10k\Omega$  bias resistor between Div and THM allows the DS2715 to sense temperature. To sense the temperature of the cell pack, locate the thermistor close to the body of a cell, preferably in the middle of the cell pack. Several recommended  $10k\Omega$  thermistors are shown in Table 3.

### Min, Max Temperature Compare

The voltage thresholds of the THM input ( $V_{THM-MIN}$ ,  $V_{THM-MAX}$ ) are set to allow charging to start if the thermistor temperature is between  $0^{\circ}C$  and  $45^{\circ}C$  when using the recommended  $10k\Omega$  bias resistor and  $10k\Omega$  thermistor circuit. If pre-charging is in progress, and the voltage on THM reaches  $V_{THM-STOP}$ , pre-charging stops and a fault condition is generated. If the voltage on THM reaches  $V_{THM-STOP}$  during FAST-CHARGE or TOPOFF, charging stops and the DS2715 enters the DONE state. FAST\_CHARGE will complete normally and TOPOFF will begin if the voltage change on THM exceeds the equivalent  $T_{TERM}$   $^{\circ}C$  per minute ( $dT/dt$  Detect specification).

**Table 3. THM THRESHOLDS**

| THM THRESHOLD | RATIO OF $V_{CBIAS}$ | THERMISTOR RESISTANCE ( $\Omega$ ) | TEMPERATURE ( $^{\circ}C$ ) |   |
|---------------|----------------------|------------------------------------|-----------------------------|---|
|               |                      |                                    | Semitec 103AT-2             | Fenwal 197-103LAG-A01<br>173-103LAF-301 |
| MIN           | 0.73                 | 27.04k                             | $0^{\circ}C$                | $4^{\circ}C$                            |
| MAX           | 0.33                 | 4.925k                             | $45^{\circ}C$               | $42^{\circ}C$                           |
| STOP          | 0.29                 | 4.085k                             | $50^{\circ}C$               | $47^{\circ}C$                           |

Used with a  $10k$  resistor, the Semitec 103AT-2 provides about 0.9% full scale per degree sensitivity. This linearity is shown in the curve in Figure 4. The left axis is the ratio of the sensed voltage to the divider's input voltage ( $V_{Cbias}$ ).

**Figure 4. RATIO OF THM PIN TO CBIAS PIN OVER TEMPERATURE**

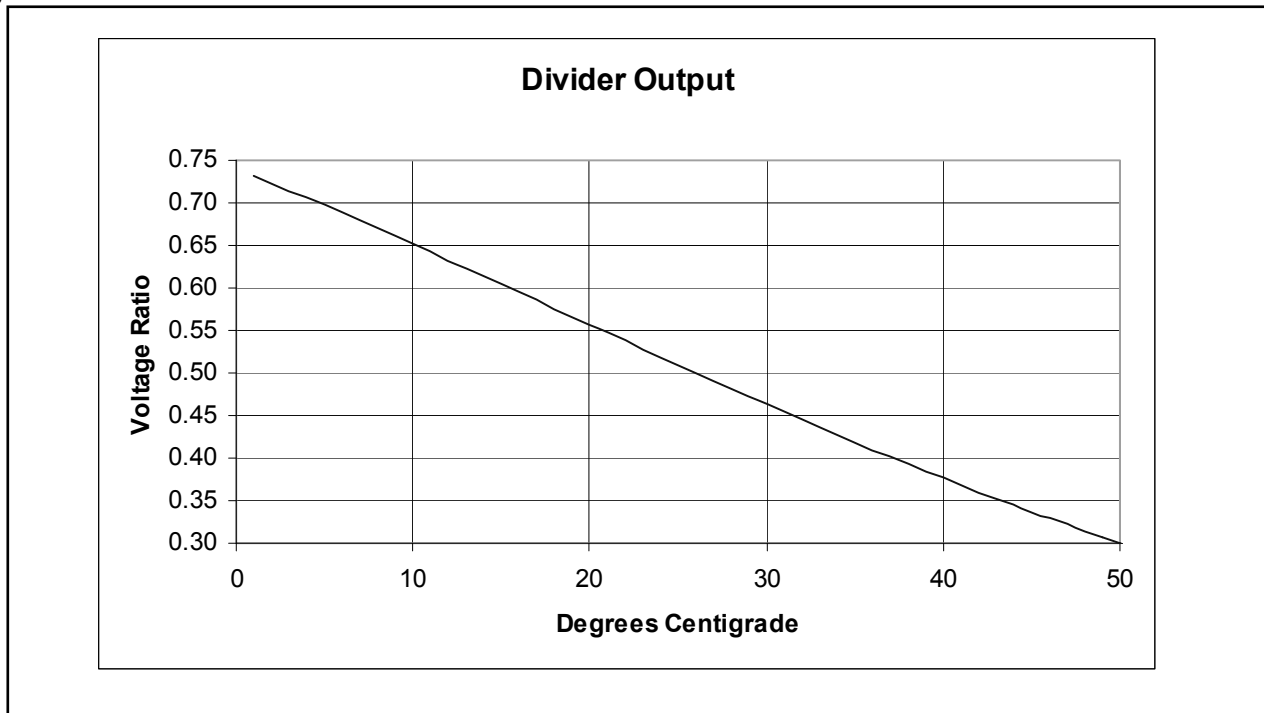

## Application Circuits

### Switchmode

Figure 5 shows a typical DS2715 switchmode application circuit for charging a 3-cell battery stack. Connecting the MODE pin to CBIAS enables the comparator mode of current regulation. The DS2715 regulates the current through the current sense resistor R7 by switching Q1 on and off as the sense resistor voltage ramps up and down toward the preset sense voltage thresholds. The .10m sense resistor along with the DC ground-referenced sense threshold level of  $-(V_{FC} + V_{HYS-FC}/2)$  sets the average charge current in the example to 1.07A. The sense resistor should have a proper power rating for the chosen charge current.

**Figure 5. TYPICAL Switchmode APPLICATION CIRCUIT FOR A 3-CELL STACK**

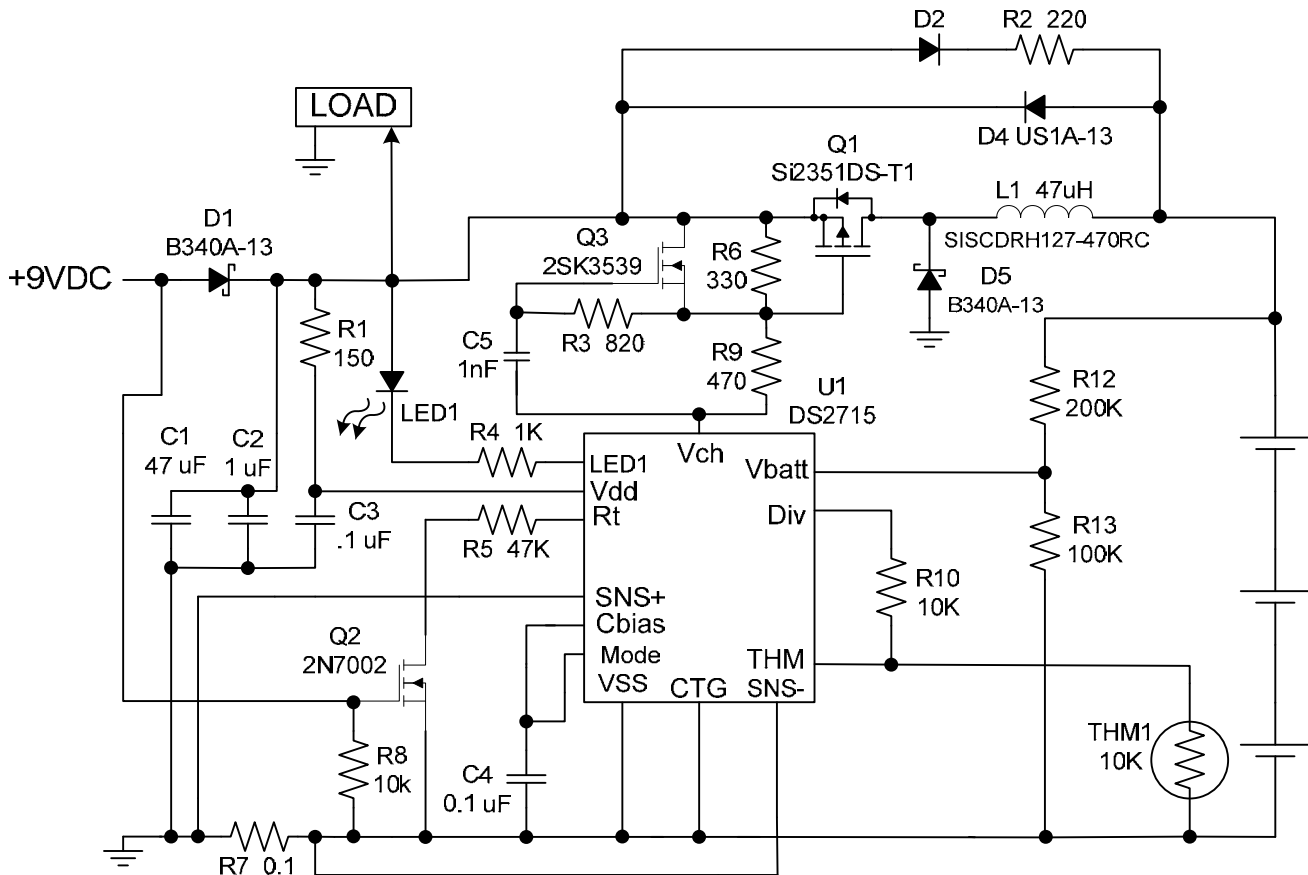

A bootstrap subcircuit with C5, R3 and Q3 is used to improve the turnoff time of Q1 to minimize switching losses. When  $V_{CH}$  is pulled low to turn on Q1, C5 is charged through the R6/R3 path. When  $V_{CH}$  is left open-circuit to turn off Q1, the voltage of the  $V_{CH}$  node jumps up close to the gate voltage of Q1. This causes the gate of Q3 to be pushed up due to the voltage across C5. Q3 is then turned on, which helps to speed turn-off of Q1 by discharging its internal capacitances. The values of the components in this section of the circuit are tuned to work with the chosen transistors. The values of R6 and R9 should be chosen so that no more than 20mA is sunk by  $V_{CH}$ . D4 is used to clamp the inductive spike that could occur if the batteries are removed during charging. This function can also be served by an energy absorbing capacitor placed in parallel with the battery stack.

Q2 is used to float the Rt pin when the supply source is disconnected. This puts the DS2715 into SUSPEND mode and resets the state machine. D1 prevents current from flowing into the charge source. D2 and R2 create the maintenance charge current path. D1, D2 and R2 should be sized appropriately for the wattage they must dissipate based on the application parameters. R1 and C3 create a low pass filter to minimize noise transfer as the DS2715 local ground moves in relation to the system or charge source ground.



## Cell Stack Size Adjustment

R12 and R13 of the application circuits form a voltage divider such that the voltage of a single cell is present on the Vbatt pin. This is required for proper operation of the DS2715. Given a 100kΩ resistor for R13, adjust R12 as follows for the number of cells in the battery pack:

$$R12 = (\text{Number of Cells} - 1) * R13$$

To charge 3-cell stacks, a value of 200kΩ is used for R12 for a 100kΩ R13.

It is important that the voltage seen by the Vbatt pin is relatively error free compared to the actual cell voltages in the battery pack. Any parasitic resistances in the connections between the battery cells and the resistor divider will cause errors that will increase with increasing charge current. The error seen by the Vbatt pin is the overall parasitic error divided by the number of cells. So, for a given parasitic resistance, it is more of a concern for circuits with a smaller number of cells. If parasitic resistances of a problematic level cannot be avoided, the connection location of the resistor divider can be manipulated to sense the true battery voltage, or the divider ratio can be adjusted to account for the sensed voltage error.

## Application PCB Layout

Proper layout rules must be followed to ensure a successful application circuit. For all modes of operation, currents in excess of 1A may flow through the charge and discharge paths. All of these paths should be properly sized to handle the worst case current flow, whether that be from charging or from powering the load with the battery.

The linear mode of operation in some cases must dissipate large amounts of heat. This is typically accomplished with either an external heatsink on the regulating transistor, or through the use of PCB copper to spread the thermal energy that must be removed. Typically, for the TO-220 package transistor used in the application example, a 1 inch square area of 1oz. copper with the transistor firmly attached will have about a 50°C/W temperature rise. Utilizing 2oz. or heavier copper can improve this number by 20% or so. If better heatsinking is needed for the ergonomic or reliability aspects of the application, an add-on heatsink must be used.

Switchmode operation presents its own unique challenges with fast voltage and current transients. Proper switchmode buck power supply layout should always be observed. Referring to the example circuit and layout of Figure 7, the loop labeled as Loop1 encompassing C1, C2, Q1 and D1 should be kept as small as possible to minimize the change in inductance that occurs when Q1 switches to the on state. Loop2 should also be minimized as much as practical, although it contains DC current components for the most part. The returning ground currents should be allowed to follow a path on a layer directly under the outgoing path since the high frequency components will try to follow the path of least impedance. Low ESR and ESL capacitors should be used when possible and for all capacitors 10uF and smaller. Typical surface mount ceramic types with a X5R or better dielectric are recommended.

**Figure 7. Switching Circuit with Example Layout**

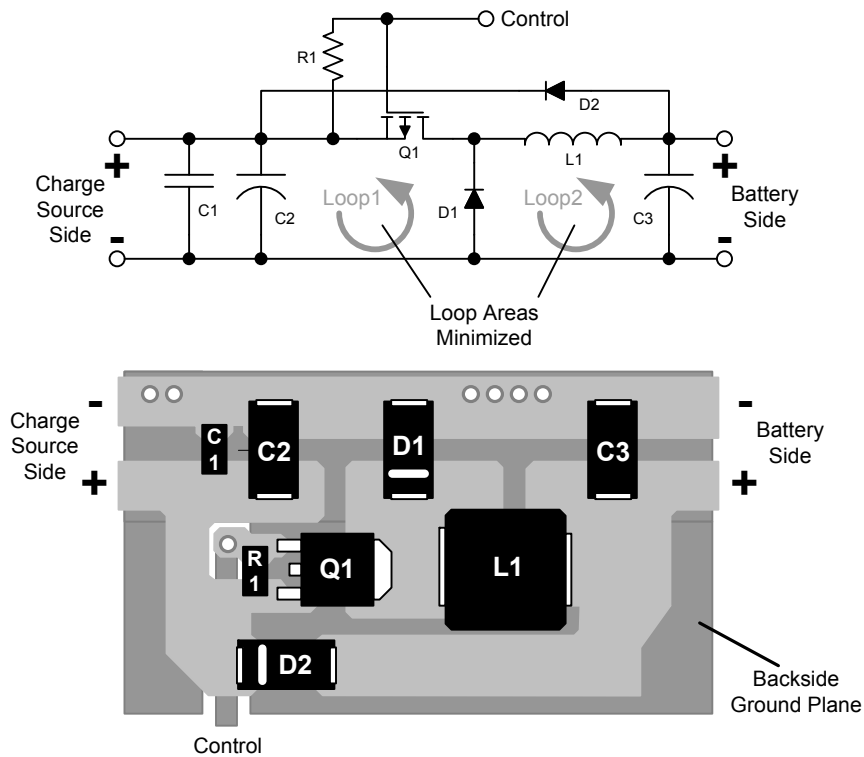

Another important layout detail is the connection of the sense resistor. Proper Kelvin connection layout should be used to ensure the signal quality viewed by the sensing circuit inside the DS2715 is adequate. Figure 8 shows a recommended connection of the sense lines to the resistor footprint.

**Figure 8. Sense Resistor Connection Layout**

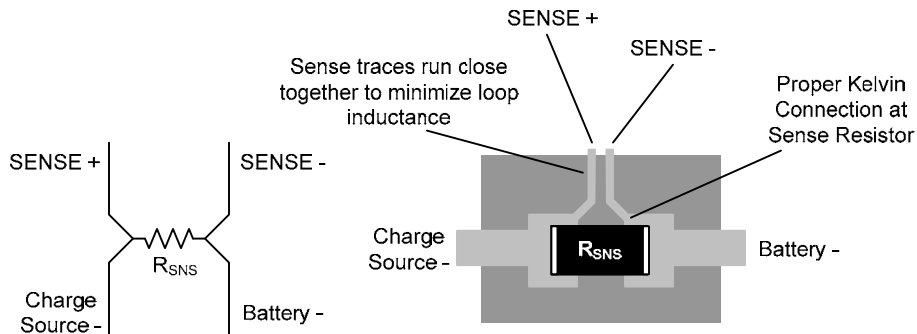

**Package Information**

For the latest package outline information and land patterns, go to [www.maxim-ic.com/packages](http://www.maxim-ic.com/packages).

| PACKAGE TYPE | PACKAGE CODE | DOCUMENT NO.            |
|--------------|--------------|-------------------------|
| 16 SO        | —            | <a href="#">21-0041</a> |

**REVISION HISTORY**

| <b>REVISION DATE</b> | <b>DESCRIPTION</b>                         | <b>PAGES CHANGED</b> |
|----------------------|--|----------------------|
| 011408               | Various comprehensive changes.             | 1, 3, 4, 6–15        |
| 031609               | Added device version DS2715B               | 1,4,7,8,10           |
| 042809               | Updated <i>Ordering Information</i> table. | 1                    |



Maxim cannot assume responsibility for use of any circuitry other than circuitry entirely embodied in a Maxim product. No circuit patent licenses are implied. Maxim reserves the right to change the circuitry and specifications without notice at any time. The parametric values (min and max limits) shown in the Electrical Characteristics table are guaranteed. Other parametric values quoted in this data sheet are provided for guidance.

**Maxim Integrated 160 Rio Robles, San Jose, CA 95134 USA 1-408-601-1000**

**17**

## Looking for pricing, stock, or lifecycle information?

Click below to explore more details on WIN SOURCE:

 [View DS2715Z+](#) on WIN SOURCE

 [Maxim Integrated](#) Information

## Optimize Your Supply Chain with WIN SOURCE Solutions

-  Global Sourcing Solution
-  Obsolete Management
-  Cost Control Management
-  Shortage Management
-  Alternative Solution
-  Excess Inventory Management