



**THE DATASHEET OF
71M6531F-IMR/F**



GENERAL DESCRIPTION

The 71M6531D/F and 71M6532D/F are highly integrated SOCs with an MPU core, RTC, FLASH and LCD driver. The patented Single Converter Technology® with a 22-bit delta-sigma ADC, four analog inputs, digital temperature compensation, precision voltage reference, battery voltage monitor and 32-bit computation engine (CE) supports a wide range of residential metering applications with very few low-cost external components.

A 32-kHz crystal time base for the entire system and internal battery backup support for RAM and RTC further reduce system cost. The IC supports 2-wire, and 3-wire single-phase and dual-phase residential metering along with tamper-detection mechanisms. The 71M6531D/F offers single-ended inputs for two current channels and two single-ended voltage inputs. The 71M6532D/F has two differential current inputs and three single-ended voltage inputs.

Maximum design flexibility is provided by multiple UARTs, I²C, μWire, up to 21 DIO pins and in-system programmable FLASH memory, which can be updated with data or application code in operation.

A complete array of ICE and development tools, programming libraries and reference designs enable rapid development and certification of TOU, AMR and Prepay meters that comply with worldwide electricity metering standards.

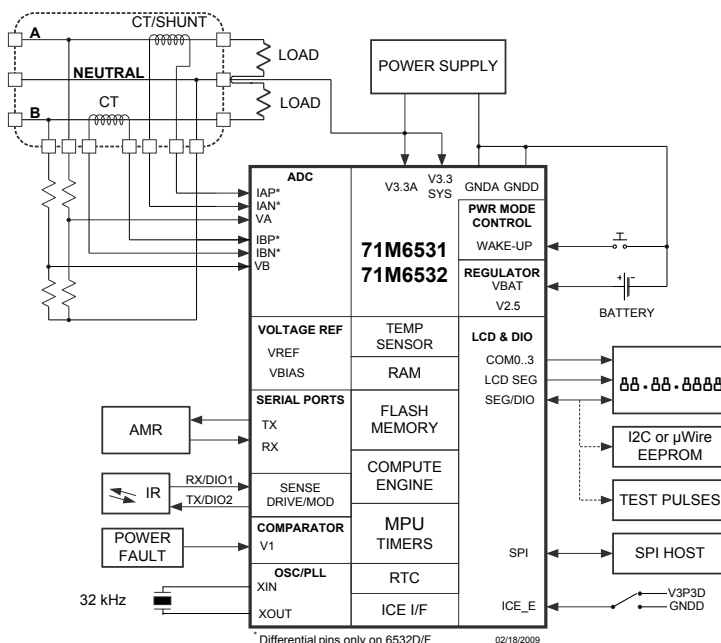

FEATURES

- Wh accuracy < 0.1% over 2000:1 current range
- Exceeds IEC62053/ANSI C12.20 standards
- Four sensor inputs
- Low-jitter Wh and VARh plus two additional pulse test outputs (4 total, 10 kHz maximum) with pulse count
- Four-quadrant metering
- Tamper detection (Neutral current with CT, Rogowski or shunt, magnetic tamper input)
- Line frequency count for RTC
- Digital temperature compensation
- Sag detection for phase A and B
- Independent 32-bit compute engine
- 46-64 Hz line frequency range with same calibration. Phase compensation ($\pm 7^\circ$)
- Three battery modes with wake-up on timer or push-button:
 - BROWNOUT Mode (52 μ A typ.)
 - LCD Mode (21 μ A typ., DAC active)
 - SLEEP Mode (0.7 μ A typ.)
- Energy display during mains power failure
- 39 mW typical consumption @ 3.3 V, MPU clock frequency 614 kHz
- 22-bit delta-sigma ADC with 3360 Hz or 2520 Hz sample rate
- 8-bit MPU (80515), 1 clock cycle per instruction, 10 MHz maximum, with integrated ICE for debug
- RTC for TOU functions with clock-rate adjust register
- Hardware watchdog timer, power fail monitor
- LCD driver with 4 common segment drivers:
 - Up to 156 (71M6531D/F) or 268 pixels (71M6532D/F)
- Up to 22 (71M6531D/F) or 43 (71M6532D/F) general-purpose I/O pins. Digital I/O pins compatible with 5 V inputs
- 32 kHz time base
- High-speed slave SPI interface to data RAM
- Two UARTs for IR and AMR, IR driver with modulation
- FLASH memory with security and in-system program update:
 - 128 KB (71M6531D/32D)
 - 256 KB (71M6531F/32F)
- 4 KB MPU XRAM
- Industrial temperature range
- 68-pin QFN package for 71M6531D/F pin-compatible with 71M6521, 100-pin LQFP package for 71M6532D/F, lead free

Table of Contents

1	Hardware Description	10
1.1	Hardware Overview	10
1.2	Analog Front End (AFE).....	10
1.2.1	Signal Input Pins	10
1.2.2	Input Multiplexer.....	11
1.2.3	A/D Converter (ADC)	12
1.2.4	FIR Filter	12
1.2.5	Voltage References	12
1.2.6	Temperature Sensor	14
1.2.7	Battery Monitor.....	14
1.2.8	AFE Functional Description	14
1.2.9	Digital Computation Engine (CE).....	15
1.2.10	Meter Equations.....	16
1.2.11	Real-Time Monitor	16
1.2.12	Pulse Generators	16
1.2.13	Data RAM (XRAM)	17
1.2.14	Delay Compensation	17
1.2.15	CE Functional Overview	17
1.3	80515 MPU Core	19
1.3.1	Memory Organization and Addressing	19
1.3.2	Special Function Registers (SFRs).....	21
1.3.3	Generic 80515 Special Function Registers	22
1.3.4	Special Function Registers (SFRs) Specific to the 71M6531D/F and 71M6532D/F	24
1.3.5	Instruction Set	26
1.3.6	UARTs	26
1.3.7	Timers and Counters	28
1.3.8	WD Timer (Software Watchdog Timer)	30
1.3.9	Interrupts.....	30
1.4	On-Chip Resources	36
1.4.1	Oscillator.....	36
1.4.2	Internal Clocks	36
1.4.3	Real-Time Clock (RTC)	37
1.4.4	Temperature Sensor	38
1.4.5	Physical Memory.....	38
1.4.6	Optical Interface.....	40
1.4.7	Digital I/O – 71M6531D/F	41
1.4.8	Digital I/O – 71M6532D/F	43
1.4.9	Digital IO – Common Characteristics for 71M6531D/F and 71M6532D/F	44
1.4.10	LCD Drivers – 71M6531D/F	45
1.4.11	LCD Drivers – 71M6532D/F	46
1.4.12	LCD Drivers – Common Characteristics for 71M6531D/F and 71M6532D/F	46
1.4.13	Battery Monitor.....	46
1.4.14	EEPROM Interface	46
1.4.15	SPI Slave Port.....	49
1.4.16	Hardware Watchdog Timer.....	52
1.4.17	Test Ports (TMUXOUT pin)	53

2	Functional Description	54
2.1	Theory of Operation	54
2.2	System Timing Summary	55
2.3	Battery Modes	56
2.3.1	BROWNOUT Mode	57
2.3.2	LCD Mode	58
2.3.3	SLEEP Mode	58
2.4	Fault and Reset Behavior	60
2.4.1	Reset Mode	60
2.4.2	Power Fault Circuit	60
2.5	Wake-Up Behavior	61
2.5.1	Wake on PB	61
2.5.2	Wake on Timer	61
2.6	Data Flow	61
2.7	CE/MPU Communication	62
3	Application Information	63
3.1	Connection of Sensors	63
3.2	Connecting 5-V Devices	63
3.3	Temperature Measurement	64
3.4	Temperature Compensation	64
3.4.1	Temperature Coefficients:	64
3.4.2	Temperature Compensation for VREF	65
3.4.3	System Temperature Compensation	65
3.4.4	Temperature Compensation for the RTC	65
3.5	Connecting LCDs	66
3.6	Connecting I ² C EEPROMs	66
3.7	Connecting Three-Wire EEPROMs	67
3.8	UART0 (TX/RX)	67
3.9	Optical Interface (UART1)	67
3.10	Connecting the V1 Pin	68
3.11	Connecting the Reset Pin	69
3.12	Connecting the Emulator Port Pins	69
3.13	Connecting a Battery	69
3.14	Flash Programming	70
3.15	MPU Firmware	70
3.16	Crystal Oscillator	70
3.17	Meter Calibration	71
4	Firmware Interface	72
4.1	I/O RAM and SFR Map – Functional Order	72
4.2	I/O RAM Description – Alphabetical Order	77
4.3	CE Interface Description	88
4.3.1	CE Program	88
4.3.2	CE Data Format	88
4.3.3	Constants	88
4.3.4	Environment	88
4.3.5	CE Calculations	89
4.3.6	CE Status and Control	89
4.3.7	CE Transfer Variables	92
4.3.8	Pulse Generation	93
4.3.9	CE Calibration Parameters	94

4.3.10	Other CE Parameters	95
4.3.11	CE Flow Diagrams	95
5	Electrical Specifications	98
5.1	Absolute Maximum Ratings	98
5.2	Recommended External Components	99
5.3	Recommended Operating Conditions	99
5.4	Performance Specifications	100
5.4.1	Input Logic Levels	100
5.4.2	Output Logic Levels	100
5.4.3	Power-Fault Comparator	100
5.4.4	Battery Monitor	100
5.4.5	Supply Current	101
5.4.6	V3P3D Switch	101
5.4.7	2.5 V Voltage Regulator	101
5.4.8	Low-Power Voltage Regulator	101
5.4.9	Crystal Oscillator	102
5.4.10	LCD DAC	102
5.4.11	LCD Drivers	102
5.4.12	Optical Interface	102
5.4.13	Temperature Sensor	103
5.4.14	VREF	103
5.4.15	ADC Converter, V3P3A Referenced	104
5.5	Timing Specifications	106
5.5.1	Flash Memory	106
5.5.2	EEPROM Interface	106
5.5.3	RESET	106
5.5.4	RTC	106
5.5.5	SPI Slave Port (MISSION Mode)	107
5.6	Typical Performance Data	108
5.6.1	Accuracy over Current	108
5.6.2	Accuracy over Temperature	108
5.7	71M6531D/F Package	109
5.7.1	Package Outline	109
5.7.2	71M6531D/F Pinout (QFN-68)	110
5.7.3	Recommended PCB Land Pattern for the QFN-68 Package	111
5.8	71M6532D/F Package	112
5.8.1	71M6532D/F Pinout (LQFP-100)	112
5.8.2	LQFP-100 Mechanical Drawing	113
5.9	Pin Descriptions	114
5.9.1	Power and Ground Pins	114
5.9.2	Analog Pins	114
5.9.3	Digital Pins	115
5.9.4	I/O Equivalent Circuits	116
6	Ordering Information	117
7	Related Information	117
8	Contact Information	117
	Appendix A: Acronyms	118
	Appendix B: Revision History	119

Figures

Figure 1: 71M6531D/F IC Functional Block Diagram	8
Figure 2: 71M6532D/F IC Functional Block Diagram	9
Figure 3: General Topology of a Chopped Amplifier	13
Figure 4: CROSS Signal with $CHOP_E[1:0] = 00$	13
Figure 5: AFE Block Diagram (Shown for the 71M6532D/F).....	14
Figure 6: Samples from Multiplexer Cycle	18
Figure 7: Accumulation Interval.....	18
Figure 8: Interrupt Structure	35
Figure 9: Optical Interface.....	41
Figure 10: Connecting an External Load to DIO Pins.....	45
Figure 11: 3-Wire Interface. Write Command, HiZ=0	48
Figure 12: 3-Wire Interface. Write Command, HiZ=1	48
Figure 13: 3-Wire Interface. Read Command.....	49
Figure 14: 3-Wire Interface. Write Command when CNT=0.....	49
Figure 15: 3-Wire Interface. Write Command when HiZ=1 and WFR=1	49
Figure 16: SPI Slave Port: Typical Read and Write operations	51
Figure 17: Functions defined by V1	52
Figure 18: Voltage, Current, Momentary and Accumulated Energy	54
Figure 19: Timing Relationship between ADC MUX, Compute Engine.....	55
Figure 20: RTM Output Format.....	55
Figure 21: Operation Modes State Diagram	56
Figure 22: Transition from BROWNOUT to MISSION Mode when System Power Returns	59
Figure 23: Power-Up Timing with V3P3SYS and VBAT tied together.....	59
Figure 24: Power-Up Timing with VBAT only.....	60
Figure 25: Wake Up Timing	61
Figure 26: MPU/CE Data Flow.....	62
Figure 27: MPU/CE Communication.....	62
Figure 28: Resistive Voltage Divider.....	63
Figure 29: CT with Single Ended (Left) and Differential Input (Right) Connection	63
Figure 30: Resistive Shunt (Left) and Rogowski Sensor (Right) Connection	63
Figure 31: Connecting LCDs.....	66
Figure 32: I ² C EEPROM Connection	66
Figure 33: Three-Wire EEPROM Connection	67
Figure 34: Connections for UART0.....	67
Figure 35: Connection for Optical Components.....	68
Figure 36: Voltage Divider for V1	68
Figure 37: External Components for the RESET Pin: Push-button (Left), Production Circuit (Right)	69
Figure 38: External Components for the Emulator Interface	69
Figure 39: Connecting a Battery	70
Figure 40: CE Data Flow: Multiplexer and ADC.....	96
Figure 41: CE Data Flow: Scaling, Gain Control, Intermediate Variables	96
Figure 42: CE Data Flow: Squaring and Summation Stages.....	97
Figure 43: SPI Slave Port (MISSION Mode) Timing	107
Figure 44: Wh Accuracy, 0.1 A to 200 A at 240 V/50 Hz and Room Temperature	108
Figure 45: QFN-68 Package Outline, Top and Side View	109
Figure 46: QFN-68 Package Outline, Bottom View	109
Figure 47: Pinout for QFN-68 Package.....	110
Figure 48: PCB Land Pattern for QFN 68 Package.....	111
Figure 49: PCB Land Pattern for LQFP-100 Package.....	112
Figure 50: LQFP-100 Package, Mechanical Drawing.....	113
Figure 51: I/O Equivalent Circuits	116

Tables

Table 1: Inputs Selected in Regular and Alternate Multiplexer Cycles.....	11
Table 2: ADC Resolution.....	12
Table 3: ADC RAM Locations.....	12
Table 4: XRAM Locations for ADC Results.....	15
Table 5: Meter Equations.....	16
Table 6: CKMPU Clock Frequencies.....	19
Table 7: Memory Map.....	20
Table 8: Internal Data Memory Map.....	21
Table 9: Special Function Register Map.....	21
Table 10: Generic 80515 SFRs - Location and Reset Values.....	22
Table 11: <i>PSW</i> Bit Functions (<i>SFR 0xD0</i>).....	23
Table 12: Port Registers.....	24
Table 13: Stretch Memory Cycle Width.....	24
Table 14: 71M6531D/F and 71M6532D/F Specific SFRs.....	24
Table 15: Baud Rate Generation.....	26
Table 16: UART Modes.....	26
Table 17: The <i>S0CON</i> (UART0) Register (<i>SFR 0x98</i>).....	27
Table 18: The <i>S1CON</i> (UART1) register (<i>SFR 0x9B</i>).....	27
Table 19: <i>PCON</i> Register Bit Description (<i>SFR 0x87</i>).....	28
Table 20: Timers/Counters Mode Description.....	28
Table 21: Allowed Timer/Counter Mode Combinations.....	29
Table 22: <i>TMOD</i> Register Bit Description (<i>SFR 0x89</i>).....	29
Table 23: The <i>TCON</i> Register Bit Functions (<i>SFR 0x88</i>).....	29
Table 24: The <i>IEN0</i> Bit Functions (<i>SFR 0xA8</i>).....	30
Table 25: The <i>IEN1</i> Bit Functions (<i>SFR 0xB8</i>).....	31
Table 26: The <i>IEN2</i> Bit Functions (<i>SFR 0x9A</i>).....	31
Table 27: <i>TCON</i> Bit Functions (<i>SFR 0x88</i>).....	31
Table 28: The <i>T2CON</i> Bit Functions (<i>SFR 0xC8</i>).....	31
Table 29: The <i>IRCON</i> Bit Functions (<i>SFR 0xC0</i>).....	31
Table 30: External MPU Interrupts.....	32
Table 31: Interrupt Enable and Flag Bits.....	32
Table 32: Interrupt Priority Level Groups.....	33
Table 33: Interrupt Priority Levels.....	33
Table 34: Interrupt Priority Registers (<i>IP0</i> and <i>IP1</i>).....	34
Table 35: Interrupt Polling Sequence.....	34
Table 36: Interrupt Vectors.....	34
Table 37: Clock System Summary.....	36
Table 38: Bank Switching with <i>FL_BANK[2:0]</i>	40
Table 39: Data/Direction Registers and Internal Resources for DIO 1-15 (71M6531D/F).....	42
Table 40: Data/Direction Registers and Internal Resources for DIO 17-29 (71M6531D/F).....	42
Table 41: Data/Direction Registers and Internal Resources for DIO 43-46 (71M6531D/F).....	42
Table 42: Data/Direction Registers and Internal Resources for DIO 1-15 (71M6532D/F).....	43
Table 43: Data/Direction Registers and Internal Resources for DIO 16-30 (71M6532D/F).....	43
Table 44: Data/Direction Registers and Internal Resources for DIO 40-51 (71M6532D/F).....	44
Table 45: <i>DIO_DIR</i> Control Bit.....	44
Table 46: Selectable Control using <i>DIO_DIR</i> Bits.....	44
Table 47: <i>EECTRL</i> Bits for 2-pin Interface.....	47
Table 48: <i>EECTRL</i> Bits for the 3-Wire Interface.....	48
Table 49: SPI Command Description.....	50
Table 50: I/O RAM Registers Accessible via SPI.....	50
Table 51: <i>TMUX[4:0]</i> Selections.....	53
Table 52: Available Circuit Functions.....	57

Table 53: I/O RAM Map in Functional Order.....	72
Table 54: I/O RAM Description - Alphabetical	77
Table 55: CE <i>EQU</i> [2:0] Equations and Element Input Mapping.....	89
Table 56: <i>CESTATUS</i> (CE RAM 0x80) Bit Definitions.....	90
Table 57: <i>CECONFIG</i> Bit Definitions	91
Table 58: Sag Threshold Control	91
Table 59: Gain Adjust Control.....	91
Table 60: CE Transfer Variables.....	92
Table 61: CE Energy Measurement Variables.....	92
Table 62: Useful CE Measurement Parameters	93
Table 63: CE Pulse Generation Parameters.....	94
Table 64: CE Calibration Parameters	94
Table 65: CE Parameters for Noise Suppression and Code Version.....	95
Table 66: Absolute Maximum Ratings	98
Table 67: Recommended External Components	99
Table 68: Recommended Operating Conditions	99
Table 69: Input Logic Levels	100
Table 70: Output Logic Levels	100
Table 71: Power-Fault Comparator Performance Specifications.....	100
Table 72: Battery Monitor Performance Specifications (<i>BME</i> = 1).....	100
Table 73: Supply Current Performance Specifications	101
Table 74: V3P3D Switch Performance Specifications	101
Table 75: 2.5 V Voltage Regulator Performance Specifications.....	101
Table 76: Low-Power Voltage Regulator Performance Specifications	101
Table 77: Crystal Oscillator Performance Specifications	102
Table 78: LCD DAC Performance Specifications	102
Table 79: LCD Driver Performance Specifications	102
Table 80: Optical Interface Performance Specifications.....	102
Table 81: Temperature Sensor Performance Specifications	103
Table 82: VREF Performance Specifications.....	103
Table 83: ADC Converter Performance Specifications.....	104
Table 84: Flash Memory Timing Specifications	106
Table 85: EEPROM Interface Timing.....	106
Table 86: RESET Timing	106
Table 87: SPI Slave Port (MISSION Mode) Timing	107
Table 88: Recommended PCB Land Pattern Dimensions.....	111
Table 89: Power and Ground Pins	114
Table 90: Analog Pins	114
Table 91: Digital Pins	115

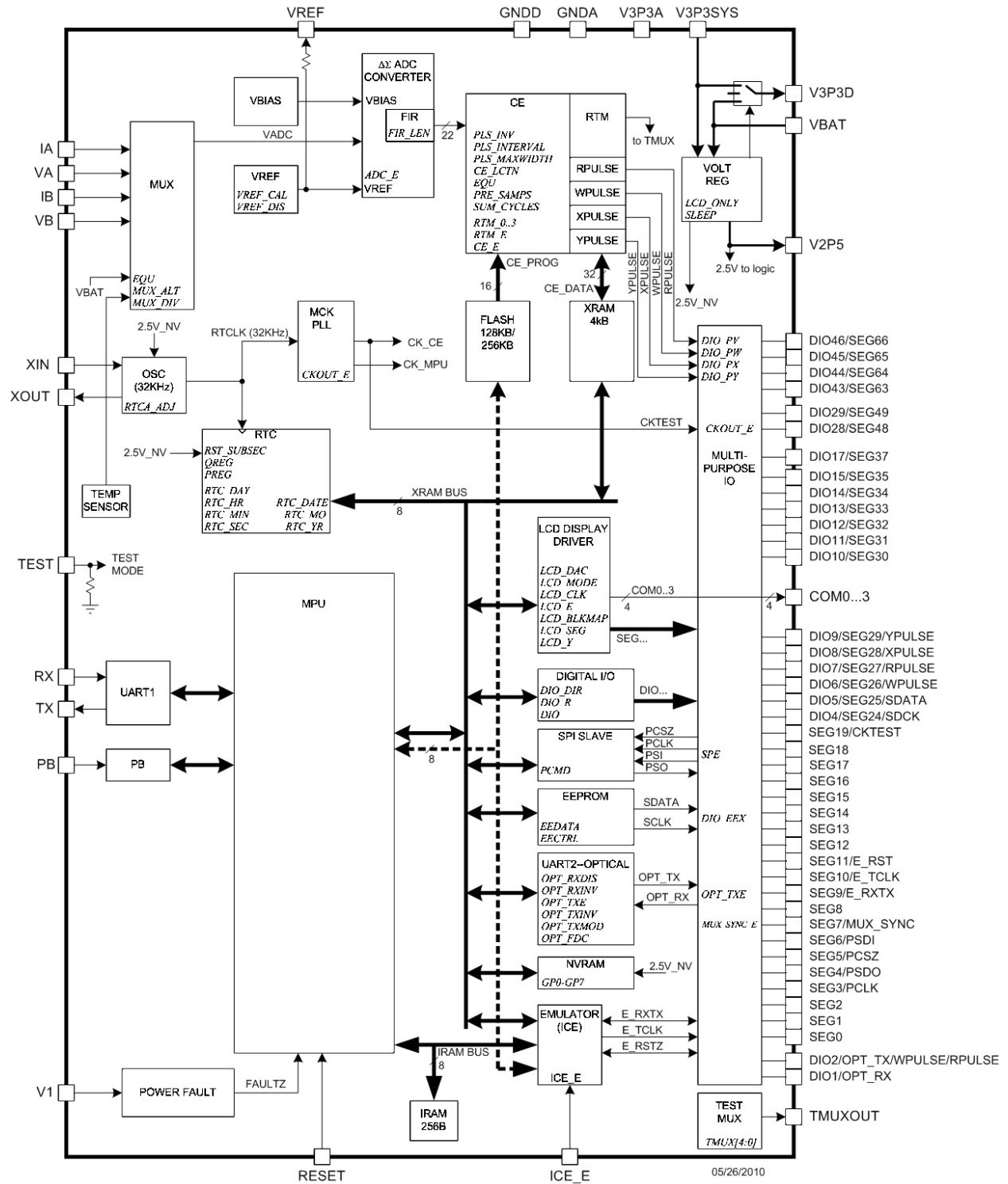

Figure 1: 71M6531D/F IC Functional Block Diagram

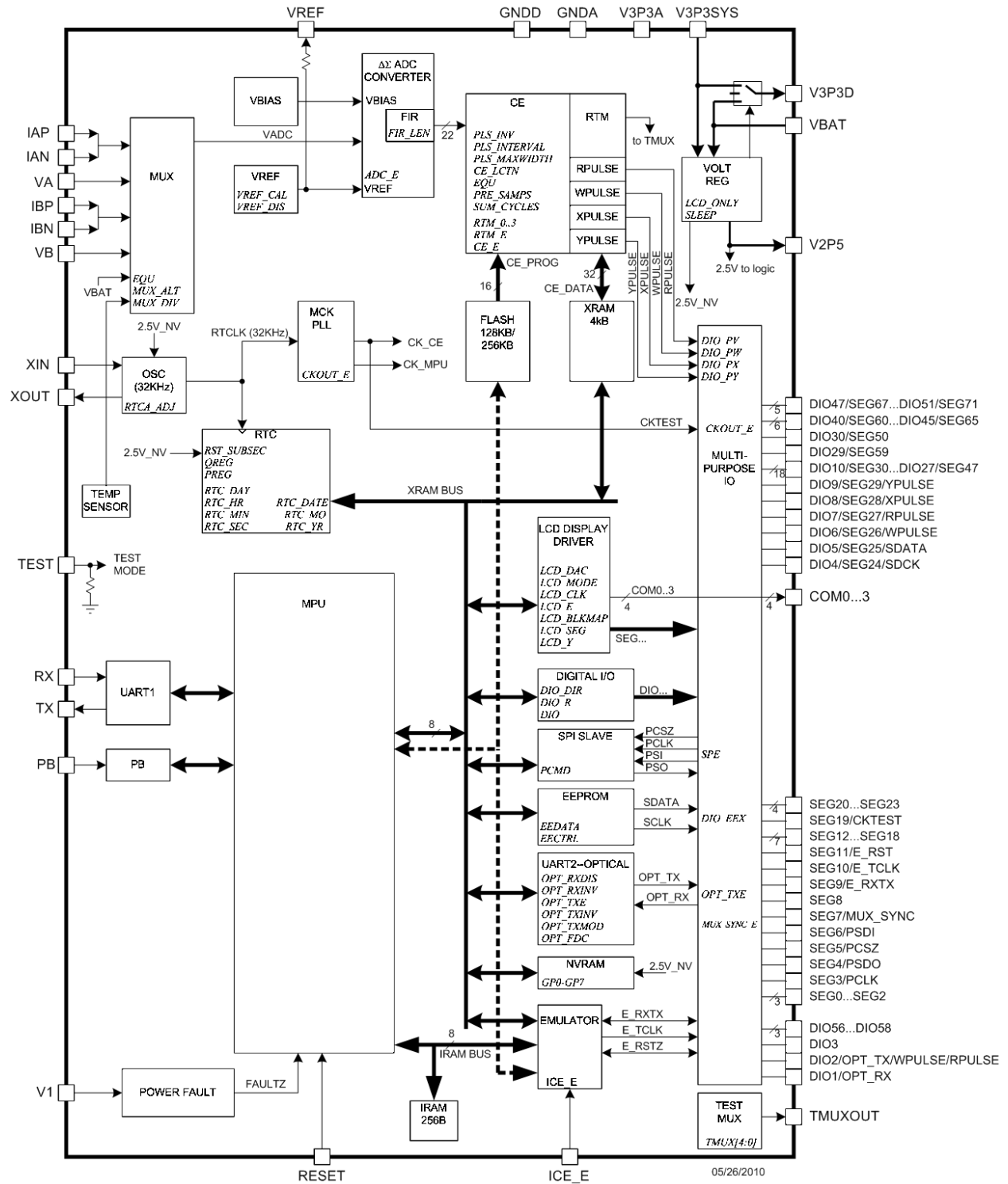

Figure 2: 71M6532D/F IC Functional Block Diagram

1 Hardware Description

1.1 Hardware Overview

The 71M6531D/F and 71M6532D/F single-chip energy meters integrates all primary functional blocks required to implement a solid-state electricity meter. Included on the chips are:

- An analog front end (AFE)
- An Independent digital computation engine (CE)
- An 8051-compatible microprocessor (MPU) which executes one instruction per clock cycle (80515)
- A voltage reference
- A temperature sensor
- LCD drivers
- RAM and Flash memory
- A real time clock (RTC)
- A variety of I/O pins

Various current sensor technologies are supported including Current Transformers (CT), Resistive Shunts and Rogowski coils.

In a typical application, the 32-bit compute engine (CE) of the 71M6531D/F and 71M6532D/F sequentially process the samples from the voltage inputs on pins IA, VA, IB, VB and performs calculations to measure active energy (Wh) and reactive energy (VARh), as well as A^2h and V^2h for four-quadrant metering. These measurements are then accessed by the MPU, processed further and output using the peripheral devices available to the MPU.

In addition to advanced measurement functions, the real time clock function allows the 71M6531D/F and 71M6532D/F to record time of use (TOU) metering information for multi-rate applications and to time-stamp tamper events. Measurements can be displayed on 3.3 V LCDs commonly used in low-temperature environments. Flexible mapping of LCD display segments facilitate integration of existing custom LCDs. Design trade-off between the number of LCD segments and DIO pins can be implemented in software to accommodate various requirements.

In addition to the temperature-trimmed ultra-precision voltage reference, the on-chip digital temperature compensation mechanism includes a temperature sensor and associated controls for correction of unwanted temperature effects on measurement and RTC accuracy, e.g. to meet the requirements of ANSI and IEC standards. Temperature-dependent external components such as a crystal oscillator, current transformers (CTs) and their corresponding signal conditioning circuits can be characterized and their correction factors can be programmed to produce electricity meters with exceptional accuracy over the industrial temperature range.

One of the two internal UARTs is adapted to support an Infrared LED with internal drive and sense configuration and can also function as a standard UART. The optical output can be modulated at 38 kHz. This flexibility makes it possible to implement AMR meters with an IR interface. A block diagram of the 71M6531D/F IC is shown in [Figure 1](#). A block diagram of the 71M6532D/F IC is shown in [Figure 2](#).

1.2 Analog Front End (AFE)

The AFE consists of an input multiplexer, a delta-sigma A/D converter and a voltage reference.

1.2.1 Signal Input Pins

All analog signal input pins are sensitive to voltage. In the 71M6531D/F, the VA and VB pins, as well as the IA and IB pins are single-ended. In the 71M6532D/F, the IAP/IAN and IBP/IBN pins can be programmed individually to be differential (see I/O RAM bit *SEL_IAN* and *SEL_IBN*) or single-ended. The differential signal is applied between the IAP and IAN input pins and between the IBP and IBN input pins. Single-ended signals are applied to the IAP and IBP input pins whereas the common signal, return, is the V3P3A pin. When using the differential mode, inputs can be chopped, i.e. a connection from V3P3A to IAP or IAN (or IBP or IBN, respectively) alternates in each multiplexer cycle.

1.2.2 Input Multiplexer

The input multiplexer supports up to four input signals that are applied to pins IA (IAP/IAN), VA, IB (IBP/IBN), and VB of the device. Additionally, using the alternate multiplexer selection, it has the ability to select temperature and the battery voltage. The multiplexer can be operated in two modes:

- During a normal multiplexer cycle, the signals from the IA (IAP/IAN), IB (IBP/IBN), VA and VB pins are selected.
- During the alternate multiplexer cycle, the temperature signal (TEMP) and the battery monitor are selected, along with some of the voltage and/or current signal sources shown in Table 1. To prevent unnecessary drainage on the battery, the battery monitor is only active when enabled with the *BME* bit (0x2020[6]) in the I/O RAM.

The alternate multiplexer cycles are usually performed infrequently (every second or so) by the MPU. In order to prevent disruption of the voltage tracking PLL and voltage allpass networks, VA is not replaced in the ALT selections. Table 1 details the regular and alternative multiplexer sequences. The computation engine (CE) fills in missing samples due to an ALT multiplexer sequence.

Table 1: Inputs Selected in Regular and Alternate Multiplexer Cycles

Time Slot	Regular Slot			Alternate Slot		
	Register	Typical Selections		Register	Typical Selections	
		RAM Address	Signal for ADC		RAM Address	Signal for ADC
0	<i>SLOT0_SEL[3:0]</i>	0	IA	<i>SLOT0_ALTSEL[3:0]</i>	A	TEMP
1	<i>SLOT1_SEL[3:0]</i>	1	VB	<i>SLOT1_ALTSEL[3:0]</i>	1	VB
2	<i>SLOT2_SEL[3:0]</i>	2	IB	<i>SLOT2_ALTSEL[3:0]</i>	B	VBAT
3	<i>SLOT3_SEL[3:0]</i>	3	VA	<i>SLOT3_ALTSEL[3:0]</i>	3	VA
–	<i>SLOT4_SEL[3:0]</i>	–	–	<i>SLOT4_ALTSEL[3:0]</i>	–	–
–	<i>SLOT5_SEL[3:0]</i>	–	–	<i>SLOT5_ALTSEL[3:0]</i>	–	–
–	<i>SLOT6_SEL[3:0]</i>	–	–	<i>SLOT6_ALTSEL[3:0]</i>	–	–
–	<i>SLOT7_SEL[3:0]</i>	–	–	<i>SLOT7_ALTSEL[3:0]</i>	–	–
–	<i>SLOT8_SEL[3:0]</i>	–	–	<i>SLOT8_ALTSEL[3:0]</i>	–	–
–	<i>SLOT9_SEL[3:0]</i>	–	–	<i>SLOT9_ALTSEL[3:0]</i>	–	–

The sequence of sampled channels is fully programmable using I/O RAM registers. *SLOTn_SEL[3:0]* selects the input for the nth state in a standard multiplexer frame, while *SLOTn_ALTSEL[3:0]* selects the input for the nth state in an alternate multiplexer frame. The states shown in Table 1 are examples for possible multiplexer state sequences.

In a typical application, IA (IAN/IAP) and IB (IBN/IBP) are connected to current transformers that sense the current on each phase of the line voltage. VA and VB are typically connected to voltage sensors through resistor dividers.

The multiplexer control circuit (MUX_CTRL signal) controls multiplexer advance, FIR initiation and VREF chopping. Additionally, MUX_CTRL launches each pass through the CE program. Conceptually, MUX_CTRL is clocked by CK32, the 32768 Hz clock from the PLL block. The behavior of MUX_CTRL is governed by *MUX_ALT*, *EQU[2:0]*, *CHOP_E[1:0]* and *MUX_DIV[3:0]*.

The *MUX_ALT* bit requests an alternative multiplexer frame. The bit may be asserted on any MPU cycle and may be subsequently de-asserted on any cycle including the next one. A rising edge on *MUX_ALT* will cause MUX_CTRL to wait until the next multiplexer frame and implement a single alternate multiplexer frame.

Another control input to the MUX is *MUX_DIV[3:0]*. These four bits can request from 1 to 10 multiplexer states per frame. The multiplexer always starts at the beginning of its list and proceeds until the number of states defined by *MUX_DIV[3:0]* have been converted.

The duration of each multiplexer state depends on the number of ADC samples processed by the FIR, which is set by *FIR_LEN[1:0]*. Each multiplexer state will start on the rising edge of CK32. The MUX_CTRL signal sends an FIR_START command to begin the calculation of a sample value from the ADC bit stream by the FIR. Upon receipt of the FIR_DONE signal from the FIR, the multiplexer will wait until the next CK32 rising edge to increment its state and initiate the next FIR conversion. FIR conversions require 1, 2, or 3 CK32 cycles. The number of CK32 cycles is determined by *FIR_LEN[1:0]*, as shown in [Table 2](#).

1.2.3 A/D Converter (ADC)

A single delta-sigma A/D converter digitizes the voltage and current inputs to the 71M6531D/F and 71M6532D/F. The resolution of the ADC is programmable using the I/O RAM *M40MHZ* and *M26MHZ* bits (see [Table 2](#)). The CE code must be tailored for use with the selected ADC resolution.

Table 2: ADC Resolution

Setting for [<i>M40MHZ</i> , <i>M26MHZ</i>]	<i>FIR_LEN[1:0]</i>	CK32 Cycles	FIR CE Cycles	Resolution
[00], [10] or [11]	0	1	138	18 bits
	1	2	288	21 bits
	2	3	384	22 bits
[01]	0	1	186	19 bits
	1	2	384	22 bits
	2	3	588	24 bits

Initiation of each ADC conversion is controlled by MUX_CTRL as described above. At the end of each ADC conversion, the FIR filter output data is stored into the CE RAM location determined by the MUX selection.

1.2.4 FIR Filter

The finite impulse response filter is an integral part of the ADC and it is optimized for use with the multiplexer. The purpose of the FIR filter is to decimate the ADC output to the desired resolution. At the end of each ADC conversion, the output data is stored into the fixed CE RAM location determined by the multiplexer selection as shown in [Table 3](#). FIR data is stored LSB justified, but shifted left by eight bits.

Table 3: ADC RAM Locations

Address (HEX)	Name	Address (HEX)	Name
0x00	IA	0x09	AUX
0x01	VB	0x0A	TEMP
0x02	IB	0x0B	VBAT
0x03	VA		

1.2.5 Voltage References

The device includes an on-chip precision bandgap voltage reference that incorporates auto-zero techniques. The reference is trimmed to minimize errors caused by component mismatch and drift. The result is a voltage output with a predictable temperature coefficient.

The amplifier within the reference is chopper stabilized, i.e. the polarity can be switched by the MPU using *CHOP_E[1:0]* (*IORAM 0x2002[5:4]*). The *CHOP_E[1:0]* field enables the MPU to operate the chopper circuit in regular or inverted operation, or in toggling mode. When the chopper circuit is toggled in between multiplexer cycles, DC offsets on the measured signals will automatically be averaged out.

The general topology of a chopped amplifier is shown in [Figure 3](#).

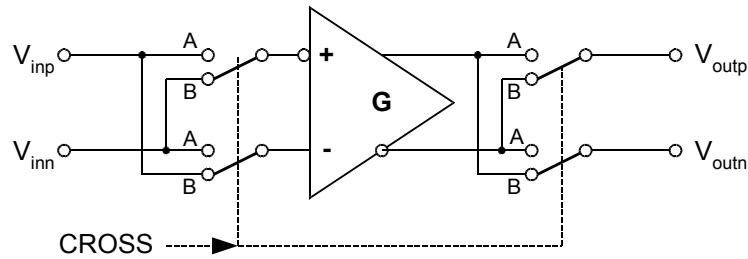

Figure 3: General Topology of a Chopped Amplifier

It is assumed that an offset voltage V_{off} appears at the positive amplifier input. With all switches, as controlled by CROSS, in the A position, the output voltage is:

$$V_{outp} - V_{outn} = G (V_{inp} + V_{off} - V_{inn}) = G (V_{inp} - V_{inn}) + G V_{off}$$

With all switches set to the B position by applying the inverted CROSS signal, the output voltage is:

$$V_{outn} - V_{outp} = G (V_{inn} - V_{inp} + V_{off}) = G (V_{inn} - V_{inp}) + G V_{off}, \text{ or}$$

$$V_{outp} - V_{outn} = G (V_{inp} - V_{inn}) - G V_{off}$$

Thus, when CROSS is toggled, e.g. after each multiplexer cycle, the offset will alternately appear on the output as positive and negative, which results in the offset effectively being eliminated, regardless of its polarity or magnitude.

When CROSS is high, the connection of the amplifier input devices is reversed. This preserves the overall polarity of that amplifier gain; it inverts its input offset. By alternately reversing the connection, the amplifier's offset is averaged to zero. This removes the most significant long-term drift mechanism in the voltage reference. The $CHOP_E[1:0]$ field controls the behavior of CROSS. The CROSS signal will reverse the amplifier connection in the voltage reference in order to negate the effects of its offset. On the first CK32 rising edge after the last multiplexer state of its sequence, the multiplexer will wait one additional CK32 cycle before beginning a new frame. At the beginning of this cycle, the value of CROSS will be updated according to the $CHOP_E[1:0]$ field. The extra CK32 cycle allows time for the chopped VREF to settle. During this cycle, MUXSYNC is held high. The leading edge of MUXSYNC initiates a pass through the CE program sequence. The beginning of the sequence is the serial readout of the four RTM words.

$CHOP_E[1:0]$ has four states: positive, reverse and two toggle states. In the positive state, $CHOP_E[1:0] = 01$, CROSS and CHOP_CLK are held low. In the reverse state, $CHOP_E[1:0] = 10$, CROSS and CHOP_CLK are held high. In the first toggle state, $CHOP_E[1:0] = 00$, CROSS is automatically toggled near the end of each multiplexer frame and an ALT frame is forced during the last multiplexer frame in each SUM cycle. It is desirable that CROSS take on alternate values during each ALT frame. For this reason, if $CHOP_E[1:0] = 00$, CROSS will not toggle at the end of the multiplexer frame immediately preceding the ALT frame in each accumulation interval.

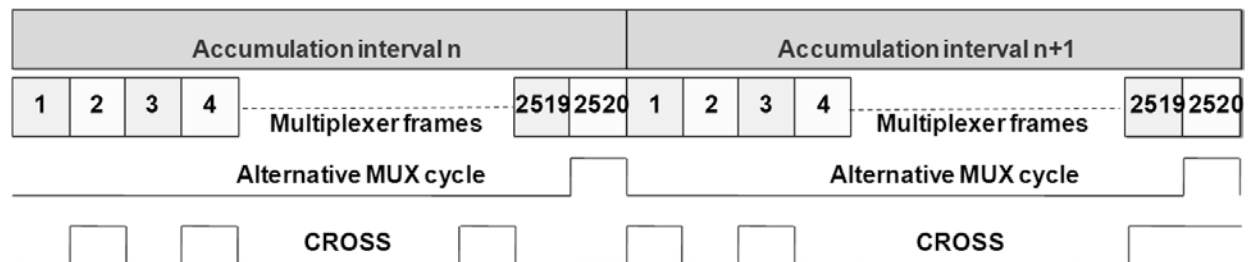

Figure 4: CROSS Signal with $CHOP_E[1:0] = 00$

Figure 4 shows CROSS over two accumulation interval when $CHOP_E[1:0] = 00$: At the end of the first interval, CROSS is low, at the end of the second interval, CROSS is high. The offset error for the two temperature measurements taken during the ALT multiplexer frames will be averaged to zero. Note that

the number of multiplexer frames in an accumulation interval is always even. Operation with $CHOP_E[1:0] = 00$ does not require control of the chopping mechanism by the MPU while eliminating the offset for temperature measurement.

In the second toggle state, $CHOP_E[1:0] = 11$, no ALT frame is forced during the last multiplexer cycle in an accumulation interval and CROSS always toggles near the end of each multiplexer frame.

The internal bias voltage, VBIAS (typically 1.6 V), is used by the ADC when measuring the temperature and battery monitor signals.

1.2.6 Temperature Sensor

The 71M6531D/F and 71M6532D/F include an on-chip temperature sensor implemented as a bandgap reference. It is used to determine the die temperature. The MPU may request an alternate multiplexer cycle containing the temperature sensor output by asserting MUX_ALT .

The primary use of the temperature data is to determine the magnitude of compensation required to offset the thermal drift in the system (see Section 3.4 Temperature Compensation).

1.2.7 Battery Monitor

The battery voltage is measured by the ADC during alternative multiplexer frames if the BME (Battery Measure Enable) bit in the I/O RAM is set. While BME is set, an on-chip 45 k Ω load resistor is applied to the battery and a scaled fraction of the battery voltage is applied to the ADC input. After each alternative MUX frame, the result of the ADC conversion is available at XRAM address 0x0B. BME is ignored and assumed zero when system power is not available ($V1 < VBIAS$). See Section 5.4.4 Battery Monitor.

1.2.8 AFE Functional Description

The AFE functions as a data acquisition system, controlled by the MPU. The main signals (IA, VA, IB and VB) are sampled, and the ADC counts obtained are stored in XRAM where they can be accessed by the CE and, if necessary, by the MPU. Alternate multiplexer cycles are initiated less frequently by the MPU to gather access to the slow temperature and battery signals.

Figure 5 shows the block diagram of the AFE, with current inputs shown only as differential pair of pins (for the 71M6531D/F, the current input for phase A is a single pin [IA]).

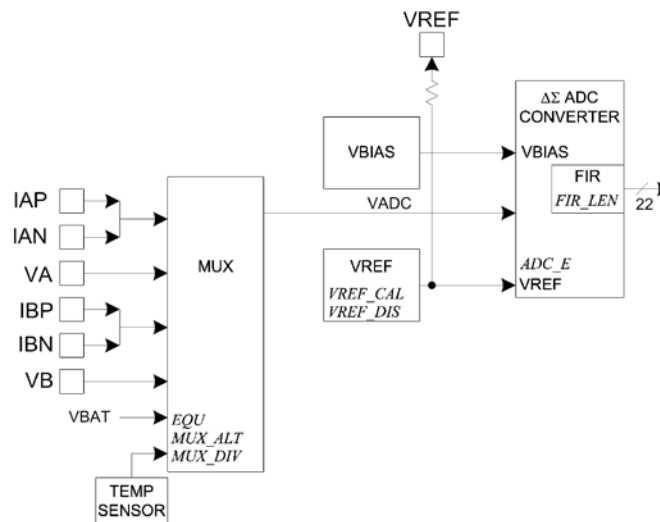

Figure 5: AFE Block Diagram (Shown for the 71M6532D/F)

1.3 Digital Computation Engine (CE)

The CE, a dedicated 32-bit signal processor, performs the precision computations necessary to accurately measure energy. The CE calculations and processes include:

- Multiplication of each current sample with its associated voltage sample to obtain the energy per sample (when multiplied with the constant sample time).
- Frequency-insensitive delay cancellation on all four channels (to compensate for the delay between samples caused by the multiplexing scheme).
- 90° phase shifter (for VAR calculations).
- Pulse generation.
- Monitoring of the input signal frequency (for frequency and phase information).
- Monitoring of the input signal amplitude (for sag detection).
- Scaling of the processed samples based on calibration coefficients.
- Scaling of all samples based on temperature compensation information (71M6532D/F only).

The CE program resides in flash memory. Common access to flash memory by CE and MPU is controlled by a memory share circuit. Each CE instruction word is two bytes long. Allocated flash space for the CE program cannot exceed 4096 16-bit words (8 KB). The CE program counter begins a pass through the CE code each time multiplexer state 0 begins. The code pass ends when a HALT instruction is executed. For proper operation, the code pass must be completed before the multiplexer cycle ends (see Section [2.2 System Timing Summary](#)).

The CE program must begin on a 1-KB boundary of the flash address. The I/O RAM register *CE_LCTN[7:0]* defines which 1-KB boundary contains the CE code. Thus, the first CE instruction is located at $1024 * CE_LCTN[7:0]$.

The CE can access up to 4 KB of data RAM (XRAM), or 1024 32-bit data words, starting at RAM address 0x0000.

The XRAM can be accessed by the FIR filter block, the RTM circuit, the CE, and the MPU. Assigned time slots are reserved for FIR, and MPU, respectively, to prevent bus contention for XRAM data access.

The MPU can read and write the XRAM as the primary means of data communication between the two processors. [Table 4](#) shows the CE addresses in XRAM allocated to analog inputs from the AFE.

Table 4: XRAM Locations for ADC Results

Address (HEX)	Name	Description
0x00	IA	Phase A current
0x01	VA	Phase A voltage
0x02	IB	Phase B current
0x03	VB	Phase B voltage
0x04...0x09	–	Not used
0x0A	TEMP	Temperature
0x0B	VBAT	Battery Voltage

The CE is aided by support hardware to facilitate implementation of equations, pulse counters and accumulators. This hardware is controlled through I/O RAM locations *EQU[2:0]* (equation assist), the *DIO_PV* and *DIO_PW* (pulse count assist) bits and *PRE_SAMPS[1:0]* and *SUM_CYCLES[5:0]* (accumulation assist).

PRE_SAMPS[1:0] and *SUM_CYCLES[5:0]* support a dual level accumulation scheme where the first accumulator accumulates results from *PRE_SAMPS[1:0]* samples and the second accumulator accumulates up to *SUM_CYCLES[5:0]* of the first accumulator results. The integration time for each energy output is $PRE_SAMPS[1:0] * SUM_CYCLES[5:0] / 2520.6$ (with $MUX_DIV[3:0] = 1$). The CE hardware issues the *XFER_BUSY* interrupt when the accumulation is complete.

1.3.1 Meter Equations

The 71M6531D/F and 71M6532D/F provide hardware assistance to the CE in order to support various meter equations. This assistance is controlled through I/O RAM location $EQU[2:0]$ (equation assist). The Compute Engine (CE) firmware for residential configurations implements the equations listed in [Table 5](#). $EQU[2:0]$ specifies the equation to be used based on the number of phases used for metering.

Table 5: Meter Equations

$EQU[2:0]$	Description	Watt and VAR Formula			Mux Sequence	ALT Mux Sequence
		Element 0	Element 1	Element 2		
0	1 element, 2 W, 1 ϕ with neutral current sense	$VA \cdot IA$	$VA \cdot IB$	N/A	Sequence is programmable with $SLOTn_SEL[3:0]$	Sequence is programmable with $SLOTn_ALTSEL[3:0]$
1	1 element, 3 W, 1 ϕ	$VA(IA-IB)/2$	N/A	N/A		
2	2 element, 3 W, 3 ϕ Delta	$VA \cdot IA$	$VB \cdot IB$	N/A		

Not all CE codes support all equations.

1.3.2 Real-Time Monitor

The CE contains a Real-Time Monitor (RTM), which can be programmed to monitor four selectable XRAM locations at full sample rate. The four monitored locations are serially output to the TMUXOUT pin via the digital output multiplexer at the beginning of each CE code pass. The RTM can be enabled and disabled with the RTM_E bit. The RTM output is clocked by CKTEST (pin SEG19/CKTEST), with the clock output enabled by setting $CKOUT_E = 1$. Each RTM word is clocked out in 35 cycles and contains a leading flag bit. See [Figure 20](#) for the RTM output format. RTM is low when not in use.

1.3.3 Pulse Generators

The 71M6531D/F and 71M6532D/F provide four pulse generators, RPULSE, WPULSE, XPULSE and YPULSE, as well as increased hardware support for the two original pulse generators (RPULSE and WPULSE). The pulse generators can be used to output CE status indicators, SAG for example, to DIO pins.

The polarity of the pulses may be inverted with the PLS_INV bit. When this bit is set, the pulses are active high, rather than the more usual active low. PLS_INV inverts all the pulse outputs.

XPULSE and YPULSE

Pulses generated by the CE may be exported to the XPULSE and YPULSE pulse outputs. Pins DIO8 and DIO9 are used for these pulses. Generally, the XPULSE and YPULSE outputs are updated once on each pass of the CE code, resulting in a pulse frequency up to a maximum of 1260Hz (assuming a MUX frame is 13 CK32 cycles).

The YPULSE pin can be used by the CE code to generate interrupts based on sag events. This method is faster than checking the sag bits by the MPU at every CE_BUSY interrupt. See [Section 4.3.6 CE Status and Control](#) for details.

RPULSE and WPULSE

During each CE code pass, the hardware stores exported WPULSE AND RPULSE sign bits in an 8-bit FIFO and outputs them at a specified interval. This permits the CE code to calculate the RPULSE and WPULSE outputs at the beginning of its code pass and to rely on hardware to spread them over the MUX frame. The FIFO is reset at the beginning of each MUX frame. The $PLS_INTERVAL$ register controls the delay to the first pulse update and the interval between subsequent updates. Its LSB is 4 CK_FIR cycles. If zero, the FIFO is deactivated and the DFFs are updated immediately. Thus, NINTERVAL is $4 * PLS_INTERVAL$.

Since the FIFO resets at the beginning of each MUX frame, the user must specify *PLS_INTERVAL* so that all of the pulse updates are output before the MUX frame completes. For instance, if the CE code outputs 5 updates per MUX interval and if the MUX interval is 1950 cycles long, the ideal value for the interval is $1950/5/4 = 97.5$. If *PLS_INTERVAL* = 98, the fifth output will occur too late and be lost. In this case, the proper value for *PLS_INTERVAL* is 97.

Hardware also provides a maximum pulse width feature. The *PLS_MAXWIDTH* register selects a maximum negative pulse width to be N_{max} updates according to the formula: $N_{max} = (2 * PLS_MAXWIDTH + 1)$. If *PLS_MAXWIDTH* = 255, no width checking is performed.

The WPULSE and RPULSE pulse generator outputs are available on DIO6 and DIO7, respectively. They can also be output on OPT_TX (see *OPT_TXE[1:0]* for details).

1.3.4 Data RAM (XRAM)

The CE and MPU use a single general-purpose Data RAM (also referred to as XRAM). The Data RAM is 1024 32-bit words, shared between the CE and the MPU using a time-multiplex method. This reduces MPU wait states when accessing CE data. When the MPU and CE are clocking at maximum frequency (10 MHz), the DRAM will make up to four accesses during each 100 ns interval. These consist of two MPU accesses, one CE access and one SPI access.

The Data RAM is 32 bits wide and uses an external multiplexer so as to appear byte-wide to the MPU. The Data RAM hardware will convert an MPU byte write operation into a read-modify-write operation that requires two Data RAM accesses. The second access is guaranteed to be available because the MPU cannot access the XRAM on two consecutive instructions unless it is using the same address.

In addition to the reduction of wait states, this arrangement permits the MPU to easily use unneeded CE data memory. Likewise, the amount of memory the CE uses is not limited by the size of a dedicated CE data RAM.

1.3.5 Delay Compensation

When measuring the energy of a phase (i.e., Wh and VARh) in a service, the voltage and current for that phase must be sampled at the same instant. Otherwise, the phase difference, ϕ , introduces errors.

$$\phi = \frac{t_{delay}}{T} \cdot 360^\circ = t_{delay} \cdot f \cdot 360^\circ$$

Where f is the frequency of the input signal and t_{delay} is the sampling delay between voltage and current.

In traditional meter ICs, sampling is accomplished by using two A/D converters per phase (one for voltage and the other one for current) controlled to sample simultaneously. The patented Single-Converter Technology[®], however, exploits the 32-bit signal processing capability of its CE to implement “constant delay” all-pass filters. These all-pass filters correct for the conversion time difference between the voltage and the corresponding current samples that are obtained with a single multiplexed A/D converter.

The “constant delay” all-pass filters provide a broad-band delay β , that is precisely matched to the difference in sample time between the voltage and the current of a given phase. This digital filter does not affect the amplitude of the signal, but provides a precisely controlled phase response. The delay compensation implemented in the CE aligns the voltage samples with their corresponding current samples by routing the voltage samples through the all-pass filter, thus delaying the voltage samples by β , resulting in the residual phase error $\beta - \phi$. The residual phase error is negligible, and is typically less than ± 1.5 millidegrees at 100Hz, thus it does not contribute to errors in the energy measurements.

1.3.6 CE Functional Overview

The ADC processes one sample per channel per multiplexer cycle. [Figure 6](#) shows the timing of the samples taken during one multiplexer cycle.

The number of samples processed during one accumulation cycle is controlled by *PRE_SAMPS[1:0]* (*IORAM 0x2001[7:6]*) and *SUM_CYCLES[5:0]* (*IORAM 0x2001[5:0]*). The integration time for each energy output is:

$$PRE_SAMPS[1:0] * SUM_CYCLES[5:0] / 2520.6, \text{ where } 2520.6 \text{ is the sample rate [Hz]}$$

For example, $PRE_SAMPS[1:0] = 42$ and $SUM_CYCLES[5:0] = 50$ will establish 2100 samples per accumulation cycle. $PRE_SAMPS[1:0] = 100$ and $SUM_CYCLES[5:0] = 21$ will result in the exact same accumulation cycle of 2100 samples or 833 ms. After an accumulation cycle is completed, the XFER_BUSY interrupt signals to the MPU that accumulated data are available.

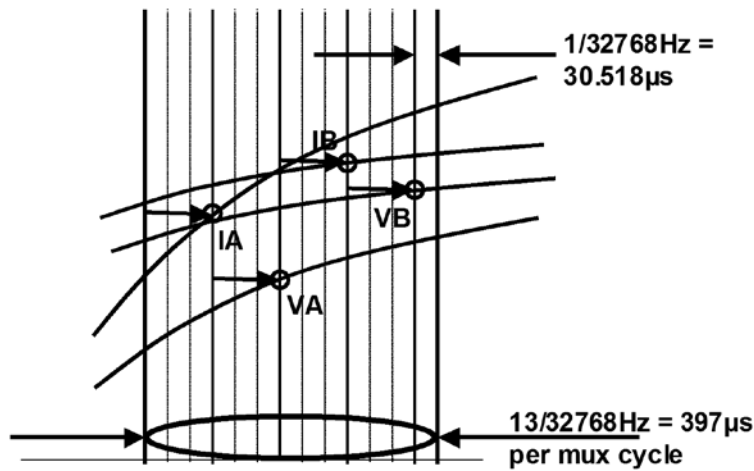

Figure 6: Samples from Multiplexer Cycle

The end of each multiplexer cycle is signaled to the MPU by the CE_BUSY interrupt. At the end of each multiplexer cycle status information, such as sag data and the digitized input signal, is available to the MPU.

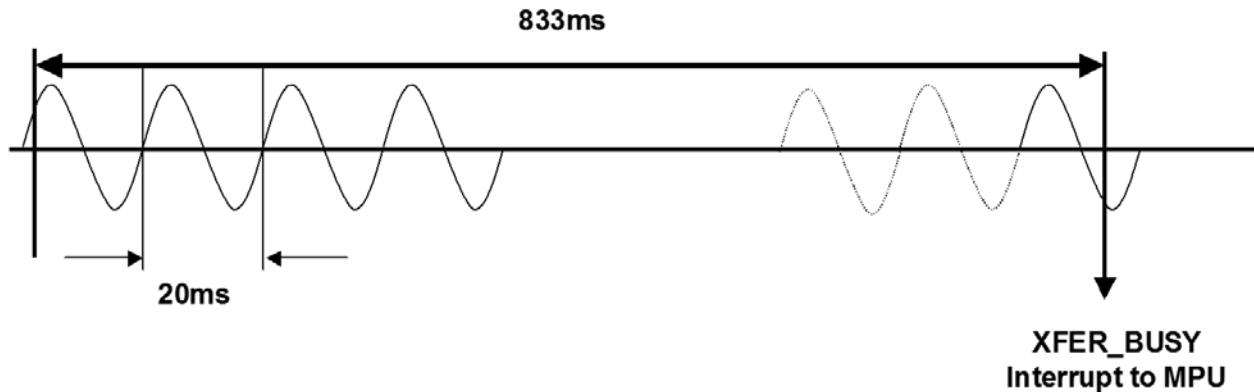

Figure 7: Accumulation Interval

Figure 7 shows the accumulation interval resulting from $PRE_SAMPS[1:0] = 42$ and $SUM_CYCLES[5:0] = 50$, consisting of 2100 samples of 397 μs each, followed by the XFER_BUSY interrupt. The sampling in this example is applied to a 50 Hz signal.

There is no correlation between the line signal frequency and the choice of $PRE_SAMPS[1:0]$ or $SUM_CYCLES[5:0]$ (even though when $SUM_CYCLES[5:0] = 42$ one set of $SUM_CYCLES[5:0]$ happens to sample a period of 16.6 ms). Furthermore, sampling does not have to start when the line voltage crosses the zero line and the length of the accumulation interval need not be an integer multiple of the signal cycles.

1.4 80515 MPU Core

The 71M6531D/F and 71M6532D/F include an 80515 MPU (8-bit, 8051-compatible) that processes most instructions in one clock cycle. Using a 10-MHz clock results in a processing throughput of 10 MIPS. The 80515 architecture eliminates redundant bus states and implements parallel execution of fetch and execution phases. Normally, a machine cycle is aligned with a memory fetch, therefore, most of the 1-byte instructions are performed in a single machine cycle (MPU clock cycle). This leads to an 8x average performance improvement (in terms of MIPS) over the Intel® 8051 device running at the same clock frequency.

Table 6 shows the CKMPU frequency as a function of the allowed combinations of the MPU clock divider $MPU_DIV[2:0]$ and the MCK divider bits $M40MHZ$ and $M26MHZ$. Actual processor clocking speed can be adjusted to the total processing demand of the application (metering calculations, AMR management, memory management, LCD driver management and I/O management) using the I/O RAM field $MPU_DIV[2:0]$ and the MCK divider bits $M40MHZ$ and $M26MHZ$, as shown in Table 6.

Table 6: CKMPU Clock Frequencies

$MPU_DIV[2:0]$	$[M40MHZ, M26MHZ]$ Values		
	[1,0]	[0,1]	[0,0]
000	9.8304 MHz	6.5536 MHz	4.9152 MHz
001	4.9152 MHz	3.2768 MHz	2.4576 MHz
010	2.4576 MHz	1.6384 MHz	1.2288 MHz
011	1.2288 MHz	819.2 kHz	614.4 kHz
100	614.4 kHz	409.6 kHz	307.2 kHz
101	307.2 kHz	204.8 kHz	153.6 kHz
110	153.6 kHz	102.4 kHz	76.80 kHz
111	153.6 kHz	102.4 kHz	76.8 kHz

Typical measurement and metering functions based on the results provided by the internal 32-bit compute engine (CE) are available for the MPU as part of Maxim's standard library. Maxim provides demonstration source code to help reduce the design cycle.

1.4.1 Memory Organization and Addressing

The 80515 MPU core incorporates the Harvard architecture with separate code and data spaces. Memory organization in the 80515 is similar to that of the industry standard 8051. There are four memory areas: Program memory (Flash, shared by MPU and CE), external RAM (Data RAM, shared by the CE and MPU, Configuration or I/O RAM), and internal data memory (Internal RAM). Table 7 shows the memory map.

Program Memory

The 80515 can address up to 64 KB of program memory space from 0x0000 to 0xFFFF. Program memory is read when the MPU fetches instructions or performs a MOVC operation. Access to program memory above 0x7FFF is controlled by the $FL_BANK[2:0]$ register (SFR 0xB6).

After reset, the MPU starts program execution from program memory location 0x0000. The lower part of the program memory includes reset and interrupt vectors. The interrupt vectors are spaced at 8-byte intervals, starting from 0x0003.

MPU External Data Memory (XRAM)

Both internal and external memory is physically located on the 71M6531 device. The external memory referred to in this documentation is only external to the 80515 MPU core.

4 KB of RAM starting at address 0x0000 is shared by the CE and MPU. The CE normally uses the first 1 KB, leaving 3 KB for the MPU. Different versions of the CE code use varying amounts. Consult the documentation for the specific code version being used for the exact limit.

- If the MPU overwrites the CE's working RAM, the CE's output may be corrupted. If the CE is disabled, the first 0x40 bytes of RAM are still unusable while $MUX_DIV[3:0] \neq 0$ because the 71M6531 ADC writes to these locations. Setting $MUX_DIV[3:0] = 0$ disables the ADC output preventing the CE from writing the first 0x40 bytes of RAM.

The 80515 writes into external data memory when the MPU executes a `MOVX @Ri,A` or `MOVX @DPTR,A` instruction. The MPU reads external data memory by executing a `MOVX A,@Ri` or `MOVX A,@DPTR` instruction (SFR *PDATA* provides the upper 8 bytes for the `MOVX A,@Ri` instruction).

Internal and External Memory Map

Table 7 shows the address, type, use and size of the various memory components.

- Only the memory ranges shown in Table 7 contain physical memory.

Table 7: Memory Map

Address (hex)	Memory Technology	Memory Type	Name	Typical Usage	Memory Size (bytes)
00000-1FFFF/ 00000-3FFFF	Flash Memory	Non-volatile	Program memory for MPU and CE	MPU Program and non-volatile data	128 KB/ 256 KB [†]
				CE program (on 1 KB boundary)	8 KB max.
0000-0FFF	Static RAM	Volatile	External RAM (XRAM)	Shared by CE and MPU	4 KB
2000-20BF, 20C8-20FF	Static RAM	Volatile	Configuration RAM, I/O RAM	Hardware control	256
20C0-20C7	Static RAM	Non-volatile (battery)	Configuration RAM, I/O RAM	Battery-buffered memory	8
0000-00FF	Static RAM	Volatile	Internal RAM	Part of 80515 Core	256

[†] Memory size depends on the IC. See Section 1.5.5 Physical Memory for details.

MOVX Addressing

There are two types of instructions differing in whether they provide an 8-bit or 16-bit indirect address to the external data RAM.

In the first type, `MOVX A,@Ri`, the contents of R0 or R1 in the current register bank provide the eight lower-ordered bits of address. The eight high-ordered bits of the address are specified with the *PDATA* SFR. This method allows the user paged access (256 pages of 256 bytes each) to all ranges of the external data RAM.

In the second type of `MOVX` instruction, `MOVX A,@DPTR`, the data pointer generates a 16-bit address. This form is faster and more efficient when accessing very large data arrays (up to 64 KB), since no additional instructions are needed to set up the eight high ordered bits of the address.

It is possible to mix the two `MOVX` types. This provides the user with four separate data pointers, two with direct access and two with paged access, to the entire 64 KB of external memory range.

Dual Data Pointer

The Dual Data Pointer accelerates the block moves of data. The standard *DPTR* is a 16-bit register that is used to address external memory or peripherals. In the 80515 core, the standard data pointer is called *DPTR*, the second data pointer is called *DPTR1*. The data pointer select bit, located in the LSB of the *DPS* register (*DPS*[0]), chooses the active pointer. *DPTR* is selected when *DPS*[0] = 0 and *DPTR1* is selected when *DPS*[0] = 1.

The user switches between pointers by toggling the LSB of the *DPS* register. The values in the data pointers are not affected by the LSB of the *DPS* register. All *DPTR* related instructions use the currently selected *DPTR* for any activity.

- The second data pointer may not be supported by certain compilers.



DPTR1 is useful for copy routines, where it can make the inner loop of the routine two instructions faster compared to the reloading of *DPTR* from registers. Any interrupt routine using *DPTR1* must save and restore *DPS*, *DPTR* and *DPTR1*, which increases stack usage and slows down interrupt latency.



By selecting the Evatronics R80515 core in the Keil compiler project settings and by using the compiler directive "MODC2", dual data pointers are enabled in certain library routines.

An alternative data pointer is available in the form of the *PDATA* register (SFR 0xBF), sometimes referred to as *USR2*). It defines the high byte of a 16-bit address when reading or writing XDATA with the instruction `MOVX A,@Ri` or `MOVX @Ri,A`.

Internal Data Memory Map and Access

The Internal data memory provides 256 bytes (0x00 to 0xFF) of data memory. The internal data memory address is always 1 byte wide. [Table 8](#) shows the internal data memory map.

The Special Function Registers (SFR) occupy the upper 128 bytes. The SFR area of internal data memory is available only by direct addressing. Indirect addressing of this area accesses the upper 128 bytes of Internal RAM. The lower 128 bytes contain working registers and bit addressable memory. The lower 32 bytes form four banks of eight registers (R0-R7). Two bits on the program memory status word (*PSW*) select which bank is in use. The next 16 bytes form a block of bit addressable memory space at bit addresses 0x00-0x7F. All of the bytes in the lower 128 bytes are accessible through direct or indirect addressing.

Table 8: Internal Data Memory Map

Address Range		Direct addressing	Indirect addressing
0x80	0xFF	Special Function Registers (SFRs)	RAM
0x30	0x7F	Byte addressable area	
0x20	0x2F	Bit addressable area	
0x00	0x1F	Register banks R0...R7	

1.4.2 Special Function Registers (SFRs)

A map of the Special Function Registers is shown in [Table 9](#).

Only a few addresses in the SFR memory space are occupied, the others are not implemented. A read access to unimplemented addresses will return undefined data, while a write access will have no effect. SFRs specific to the 71M6531D/F and 71M6532D/F are shown in **bold** print on a gray field. The registers at 0x80, 0x88, 0x90, etc., are bit addressable, all others are byte addressable. See the restrictions for the *INTBITS* register in [Table 14](#).

Table 9: Special Function Register Map

Hex/ Bin	Bit Addressable	Byte Addressable							Bin/ Hex
	X000	X001	X010	X011	X100	X101	X110	X111	
F8	<i>INTBITS</i>								FF
F0	<i>B</i>								F7
E8	<i>IFLAGS</i>								EF
E0	<i>A</i>								E7
D8	<i>WDCON</i>								DF
D0	<i>PSW</i>								D7
C8	<i>T2CON</i>								CF
C0	<i>IRCON</i>								C7
B8	<i>IEN1</i>	<i>IP1</i>	<i>S0RELH</i>	<i>S1RELH</i>				<i>PDATA</i>	BF
B0	<i>P3</i>		<i>FLSHCTL</i>				<i>FL_BANK</i>	<i>PGADR</i>	B7
A8	<i>IEN0</i>	<i>IP0</i>	<i>S0RELL</i>						AF
A0	<i>P2</i>	<i>DIR2</i>	<i>DIR0</i>						A7
98	<i>S0CON</i>	<i>S0BUF</i>	<i>IEN2</i>	<i>S1CON</i>	<i>S1BUF</i>	<i>S1RELL</i>	<i>EEDATA</i>	<i>EECTRL</i>	9F
90	<i>P1</i>	<i>DIR1</i>	<i>DPS</i>		<i>ERASE</i>				97
88	<i>TCON</i>	<i>TMOD</i>	<i>TL0</i>	<i>TL1</i>	<i>TH0</i>	<i>TH1</i>	<i>CKCON</i>		8F
80	<i>P0</i>	<i>SP</i>	<i>DPL</i>	<i>DPH</i>	<i>DPL1</i>	<i>DPH1</i>		<i>PCON</i>	87

1.4.3 Generic 80515 Special Function Registers

Table 10 shows the location, description and reset or power-up value of the generic 80515 SFRs. Additional descriptions of the registers can be found at the page numbers listed in the table.

Table 10: Generic 80515 SFRs - Location and Reset Values

Name	Address (Hex)	Reset value (Hex)	Description	Page
<i>P0</i>	0x80	0xFF	Port 0	24
<i>SP</i>	0x81	0x07	Stack Pointer	23
<i>DPL</i>	0x82	0x00	Data Pointer Low 0	23
<i>DPH</i>	0x83	0x00	Data Pointer High 0	23
<i>DPL1</i>	0x84	0x00	Data Pointer Low 1	23
<i>DPH1</i>	0x85	0x00	Data Pointer High 1	23
<i>PCON</i>	0x87	0x00	UART Speed Control, Idle and Stop mode Control	28
<i>TCON</i>	0x88	0x00	Timer/Counter Control	31
<i>TMOD</i>	0x89	0x00	Timer Mode Control	29
<i>TL0</i>	0x8A	0x00	Timer 0, low byte	28
<i>TL1</i>	0x8B	0x00	Timer 1, high byte	28
<i>TH0</i>	0x8C	0x00	Timer 0, low byte	28
<i>TH1</i>	0x8D	0x00	Timer 1, high byte	28
<i>CKCON</i>	0x8E	0x01	Clock Control (Stretch=1)	24
<i>P1</i>	0x90	0xFF	Port 1	23
<i>DPS</i>	0x92	0x00	Data Pointer select Register	20
<i>S0CON</i>	0x98	0x00	Serial Port 0, Control Register	27
<i>S0BUF</i>	0x99	0x00	Serial Port 0, Data Buffer	26
<i>IEN2</i>	0x9A	0x00	Interrupt Enable Register 2	31
<i>S1CON</i>	0x9B	0x00	Serial Port 1, Control Register	27
<i>S1BUF</i>	0x9C	0x00	Serial Port 1, Data Buffer	26
<i>SIRELL</i>	0x9D	0x00	Serial Port 1, Reload Register, low byte	26
<i>P2</i>	0xA0	0xFF	Port 2	23
<i>IEN0</i>	0xA8	0x00	Interrupt Enable Register 0	30
<i>IP0</i>	0xA9	0x00	Interrupt Priority Register 0	33
<i>S0RELL</i>	0xAA	0xD9	Serial Port 0, Reload Register, low byte	26
<i>P3</i>	0xB0	0xFF	Port 3	23
<i>IEN1</i>	0xB8	0x00	Interrupt Enable Register 1	31
<i>IP1</i>	0xB9	0x00	Interrupt Priority Register 1	33
<i>S0RELH</i>	0xBA	0x03	Serial Port 0, Reload Register, high byte	26
<i>S1RELH</i>	0xBB	0x03	Serial Port 1, Reload Register, high byte	26
<i>PDATA</i>	0xBF	0x00	High address byte for MOVX@Ri - also called <i>USR2</i>	20
<i>IRCON</i>	0xC0	0x00	Interrupt Request Control Register	31
<i>T2CON</i>	0xC8	0x00	Polarity for INT2 and INT3	31
<i>PSW</i>	0xD0	0x00	Program Status Word	23
<i>WDCON</i>	0xD8	0x00	Baud Rate Control Register (only WDCON[7] bit used)	26
<i>A</i>	0xE0	0x00	Accumulator	23
<i>B</i>	0xF0	0x00	B Register	23

Accumulator (*ACC, A, SFR 0xE0*):

ACC is the accumulator register. Most instructions use the accumulator to hold the operand. The mnemonics for accumulator-specific instructions refer to accumulator as *A*, not *ACC*.

***B* Register (*SFR 0xF0*):**

The *B* register is used during multiply and divide instructions. It can also be used as a scratch-pad register to hold temporary data.

Program Status Word (*PSW, SFR 0xD0*):

This register contains various flags and control bits for the selection of the register banks (see [Table 11](#)).

Table 11: *PSW* Bit Functions (*SFR 0xD0*)

<i>PSW</i> Bit	Symbol	Function																
7	<i>CV</i>	Carry flag.																
6	<i>AC</i>	Auxiliary Carry flag for BCD operations.																
5	<i>F0</i>	General-purpose Flag 0 available for user. <input checked="" type="checkbox"/> <i>F0</i> is not to be confused with the <i>F0</i> flag in the <i>CESTATUS</i> register.																
4	<i>RSI</i>	Register bank select control bits. The contents of <i>RSI</i> and <i>RS0</i> select the working register bank:																
			<table border="1"> <thead> <tr> <th><i>RSI/RS0</i></th> <th>Bank selected</th> <th>Location</th> </tr> </thead> <tbody> <tr> <td>00</td> <td>Bank 0</td> <td>0x00 – 0x07</td> </tr> <tr> <td>01</td> <td>Bank 1</td> <td>0x08 – 0x0F</td> </tr> <tr> <td>10</td> <td>Bank 2</td> <td>0x10 – 0x17</td> </tr> <tr> <td>11</td> <td>Bank 3</td> <td>0x18 – 0x1F</td> </tr> </tbody> </table>	<i>RSI/RS0</i>	Bank selected	Location	00	Bank 0	0x00 – 0x07	01	Bank 1	0x08 – 0x0F	10	Bank 2	0x10 – 0x17	11	Bank 3	0x18 – 0x1F
<i>RSI/RS0</i>	Bank selected		Location															
00	Bank 0		0x00 – 0x07															
01	Bank 1	0x08 – 0x0F																
10	Bank 2	0x10 – 0x17																
11	Bank 3	0x18 – 0x1F																
3	<i>RS0</i>																	
2	<i>OV</i>	Overflow flag.																
1	-	User defined flag.																
0	<i>P</i>	Parity flag, affected by hardware to indicate odd or even number of one bits in the Accumulator, i.e. even parity.																

Stack Pointer (*SP, SFR 0x81*):

The stack pointer is a 1-byte register initialized to 0x07 after reset. This register is incremented before *PUSH* and *CALL* instructions, causing the stack to begin at location 0x08.

Data Pointer:

The data pointers (*DPTR* and *DPRT1*) are 2 bytes wide. The lower part is *DPL* (*SFR 0x82*) and *DPL1* (*SFR 0x84*) and the highest is *DPH* (*SFR 0x83*) and *DPH1* (*SFR 0x85*). The data pointers can be loaded as two registers (e.g. *MOV DPL,#data8*). They are generally used to access external code or data space (e.g. *MOVC A,@A+DPTR* or *MOVX A,@DPTR* respectively).

Program Counter:

The program counter (*PC*) is 2 bytes wide and initialized to 0x0000 after reset. The *PC* is incremented when fetching operation code or when operating on data from program memory.

Port Registers:

The I/O ports are controlled by Special Function Registers *P0*, *P1* and *P2* as shown in [Table 12](#). The contents of the SFR can be observed on corresponding pins on the chip. Writing a 1 to any of the ports causes the corresponding pin to be at high level (V3P3). Writing a 0 causes the corresponding pin to be held at a low level (GND). The data direction registers *DIR0*, *DIR1* and *DIR2* define individual pins as input or output pins (see Sections [1.5.7 Digital I/O – 71M6531D/F](#) or [1.5.8 Digital I/O – 71M6532D/F](#)).

Table 12: Port Registers

Register	SFR Address	R/W	Description
<i>P0</i>	0x80	R/W	Register for port 0 read and write operations.
<i>DIR0</i>	0xA2	R/W	Data direction register for port 0. Setting a bit to 1 indicates that the corresponding pin is an output.
<i>P1</i>	0x90	R/W	Register for port 1 read and write operations.
<i>DIR1</i>	0x91	R/W	Data direction register for port 1.
<i>P2</i>	0xA0	R/W	Register for port 2 read and write operations.
<i>DIR2</i>	0xA1	R/W	Data direction register for port 2.

All DIO ports on the chip are bi-directional. Each of them consists of a Latch (SFR *P0* to *P2*), an output driver and an input buffer, therefore the MPU can output or read data through any of these ports. Even if a DIO pin is configured as an output, the state of the pin can still be read by the MPU, for example when counting pulses issued via DIO pins that are under CE control.



The technique of reading the status of or generating interrupts based on DIO pins configured as outputs can be used to implement pulse counting.

Clock Stretching (*CKCON[2:0]*, SFR 0x8E)

The *CKCON[2:0]* field defines the stretch memory cycles that could be used for MOVX instructions when accessing slow external peripherals. The practical value of this register for the 71M653x is to guarantee access to XRAM between CE, MPU, and SPI. The default setting of *CKCON[2:0]* (001) should not be changed. Table 13 shows how the signals of the External Memory Interface change when stretch values are set from 0 to 7. The widths of the signals are counted in MPU clock cycles. The post-reset state of the *CKCON[2:0]* field (001), which is shown in **bold** in the table, performs the MOVX instructions with a stretch value equal to 1.

Table 13: Stretch Memory Cycle Width

<i>CKCON[2:0]</i>	Stretch Value	Read signal width		Write signal width	
		memaddr	memrd	memaddr	memwr
000	0	1	1	2	1
001	1	2	2	3	1
010	2	3	3	4	2
011	3	4	4	5	3
100	4	5	5	6	4
101	5	6	6	7	5
110	6	7	7	8	6
111	7	8	8	9	7

1.4.4 Special Function Registers (SFRs) Specific to the 71M6531D/F and 71M6532D/F

Table 14 shows the location and description of the SFRs specific to the 71M6531D/F and 71M6532D/F.

Table 14: 71M6531D/F and 71M6532D/F Specific SFRs

Register (Alternate Name)	SFR Address	Bit Field Name	R/W	Description
<i>EEDATA</i>	0x9E		R/W	I ² C EEPROM interface data register.
<i>EECTRL</i>	0x9F		R/W	I ² C EEPROM interface control register. See Section 1.5.14 EEPROM Interface for a description of the command and status bits available for <i>EECTRL</i> .

Register (Alternate Name)	SFR Address	Bit Field Name	R/W	Description
<i>ERASE</i> (<i>FLSH_ERASE</i>)	0x94		W	This register is used to initiate either the Flash Mass Erase cycle or the Flash Page Erase cycle. See the Flash Memory section for details.
<i>FL_BANK</i>	0xB6[2:0]		R/W	Flash Bank Selection.
<i>PGADDR</i> (<i>FLSH_PGADR[5:0]</i>)	0xB7		R/W	Flash Page Erase Address register. Contains the flash memory page address (page 0 through page 127) that will be erased during the Page Erase cycle (default = 0x00). Must be re-written for each new Page Erase cycle.
<i>FLSHCRL</i>	0xB2[0]	<i>FLSH_PWE</i>	R/W	Program Write Enable: 0: MOVX commands refer to XRAM Space, normal operation (default). 1: MOVX @DPTR,A moves A to Program Space (Flash) @ DPTR.
	0xB2[1]	<i>FLSH_MEEN</i>	W	Mass Erase Enable: 0: Mass Erase disabled (default). 1: Mass Erase enabled. Must be re-written for each new Mass Erase cycle.
	0xB2[6]	<i>SECURE</i>	R/W	Enables security provisions that prevent external reading of flash memory and CE program RAM. This bit is reset on chip reset and may only be set. Attempts to write zero are ignored.
	0xB2[7]	<i>PREBOOT</i>	R	Indicates that the preboot sequence is active.
<i>IFLAGS</i>	0xE8[0]	<i>IE_XFER</i>	R/W	This flag monitors the XFER_BUSY interrupt. It is set by hardware and must be cleared by the interrupt handler.
	0xE8[1]	<i>IE_RTC</i>	R/W	This flag monitors the RTC_1SEC interrupt. It is set by the hardware and must be cleared by the interrupt handler.
	0xE8[2]	<i>FWCOL1</i>	R/W	This flag indicates that a flash write was in progress while the CE was busy.
	0xE8[3]	<i>FWCOL0</i>	R/W	This flag indicates that a flash write was attempted when the CE was attempting to begin a code pass.
	0xE8[4]	<i>IE_PB</i>	R/W	This flag indicates that the wake-up pushbutton was pressed.
	0xE8[5]	<i>IE_WAKE</i>	R/W	This flag indicates that the MPU was awakened by the autowake timer.
	0xE8[6]	<i>PLL_RISE</i>	R/W	PLL_RISE Interrupt Flag: Write 0 to clear the <i>PLL_RISE</i> interrupt flag.
	0xE8[7]	<i>PLL_FALL</i>	R/W	PLL_FALL Interrupt Flag: Write 0 to clear the <i>PLL_FALL</i> interrupt flag.
<i>INTBITS</i> (<i>INT0 ... INT6</i>)	0xF8[6:0]	<i>INT6 ... INT0</i>	R	Interrupt inputs. The MPU may read these bits to see the status of external interrupts <i>INT0</i> up to <i>INT6</i> . These bits do not have any memory and are primarily intended for debug use.
	0xF8[7]	<i>WD_RST</i>	W	The WDT is reset when a 1 is written to this bit.
	<input checked="" type="checkbox"/> Only byte operations on the entire <i>INTBITS</i> register should be used when writing. The byte must have all bits set except the bits that are to be cleared.			

1.4.5 Instruction Set

All instructions of the generic 8051 microcontroller are supported. A complete list of the instruction set and of the associated op-codes is contained in the *71M653X Software User's Guide (SUG)*.

1.4.6 UARTs

The 71M6531D/F and 71M6532D/F include a UART (UART0) that can be programmed to communicate with a variety of AMR modules. A second UART (UART1) is connected to the optical port, as described in Section 1.5.6 [Optical Interface](#).

The UARTs are dedicated 2-wire serial interfaces, which can communicate with an external host processor at up to 38,400 bits/s (with MPU clock = 1.2288 MHz). The operation of the RX and TX UART0 pins is as follows:

- UART0 RX: Serial input data are applied at this pin. Conforming to RS-232 standard, the bytes are input LSB first.
- UART0 TX: This pin is used to output the serial data. The bytes are output LSB first.

The 71M6531D/F and 71M6532D/F have several UART-related registers for the control and buffering of serial data.

A single SFR register serves as both the transmit buffer and receive buffer (*SOBUF*, SFR 0x99 for UART0 and *SIBUF*, SFR 0x9C for UART1). When written by the MPU, *SOBUF* and *SIBUF* act as transmit buffers for their respective channels, and when read by the MPU, they act as receive buffers. Writing data to the transmit buffer starts the transmission by the associated UART. Received data are available by reading from the receive buffer. Both UARTs can simultaneously transmit and receive data.

WDCON[7] (SFR 0xD8) selects whether timer 1 or the internal baud rate generator is used. All UART transfers are programmable for parity enable, parity, 2 stop bits/1 stop bit and XON/XOFF options for variable communication baud rates from 300 to 38400 bps. [Table 15](#) shows how the baud rates are calculated. [Table 16](#) shows the selectable UART operation modes.

Table 15: Baud Rate Generation

	Using Timer 1 (<i>WDCON[7]</i> = 0)	Using Internal Baud Rate Generator (<i>WDCON[7]</i> = 1)
UART0	$2^{\text{smod}} * f_{\text{CKMPU}} / (384 * (256 - \text{TH1}))$	$2^{\text{smod}} * f_{\text{CKMPU}} / (64 * (2^{10} - \text{SOREL}))$
UART1	N/A	$f_{\text{CKMPU}} / (32 * (2^{10} - \text{SIREL}))$

SOREL and *SIREL* are 10-bit values derived by combining bits from the respective timer reload registers (*SORELL*, *SORELH*, *SIRELL*, *SIRELH*). *SMOD* is the *SMOD* bit in the SFR *PCON* register. *TH1* is the high byte of timer 1.

Table 16: UART Modes

	UART 0	UART 1
Mode 0	N/A	Start bit, 8 data bits, parity, stop bit, variable baud rate (internal baud rate generator)
Mode 1	Start bit, 8 data bits, stop bit, variable baud rate (internal baud rate generator or timer 1)	Start bit, 8 data bits, stop bit, variable baud rate (internal baud rate generator)
Mode 2	Start bit, 8 data bits, parity, stop bit, fixed baud rate 1/32 or 1/64 of f_{CKMPU}	N/A
Mode 3	Start bit, 8 data bits, parity, stop bit, variable baud rate (internal baud rate generator or timer 1)	N/A



Parity of serial data is available through the P flag of the accumulator. 7-bit serial modes with parity, such as those used by the FLAG protocol, can be simulated by setting and reading bit 7 of 8-bit output data. 7-bit serial modes without parity can be simulated by setting bit 7 to a constant 1. 8-bit serial modes with parity can be simulated by setting and reading the 9th bit, using the control bits *TB80* (*SOCON[3]*) and *TB81* (*SICON[3]*) in the *SOCON* (SFR 0x98) and *SICON* (SFR 0x9B) SFRs for transmit and *RB81* (*SICON[2]*) for receive operations.

The feature of receiving 9 bits (Mode 3 for UART0, Mode A for UART1) can be used as handshake signals for inter-processor communication in multi-processor systems. In this case, the slave processors have bit *SM20* (*S0CON[5]*) for UART0, or *SM21* (*S1CON[5]*) for UART1, set to 1. When the master processor outputs the slave's address, it sets the 9th bit to 1, causing a serial port receive interrupt in all the slaves. The slave processors compare the received byte with their address. If there is a match, the addressed slave will clear *SM20* or *SM21* and receive the rest of the message. All other slaves will ignore the message. After addressing the slave, the host outputs the rest of the message with the 9th bit set to 0, so no additional serial port receive interrupts will be generated.

UART Control Registers:

The functions of UART0 and UART1 depend on the setting of the Serial Port Control Registers *S0CON* and *S1CON* shown in [Table 17](#) and [Table 18](#), respectively and the *PCON* register shown in [Table 19](#).



Since the *TI0*, *RI0*, *TI1* and *RI1* bits are in an SFR bit addressable byte, common practice would be to clear them with a bit operation, but this **must be avoided**. The hardware implements bit operations as a byte wide read-modify-write hardware macro. If an interrupt occurs after the read, but before the write, its flag will be cleared unintentionally.

The proper way to clear these flag bits is to write a byte mask consisting of all ones except for a zero in the location of the bit to be cleared. The flag bits are configured in hardware to ignore ones written to them.

Table 17: The *S0CON* (UART0) Register (SFR 0x98)

Bit	Symbol	Function																				
<i>S0CON[7]</i>	<i>SM0</i>	The <i>SM0</i> and <i>SM1</i> bits set the UART0 mode: <table border="1" style="margin-left: 20px;"> <thead> <tr> <th>Mode</th> <th>Description</th> <th><i>SM0</i></th> <th><i>SM1</i></th> </tr> </thead> <tbody> <tr> <td>0</td> <td>N/A</td> <td>0</td> <td>0</td> </tr> <tr> <td>1</td> <td>8-bit UART</td> <td>0</td> <td>1</td> </tr> <tr> <td>2</td> <td>9-bit UART</td> <td>1</td> <td>0</td> </tr> <tr> <td>3</td> <td>9-bit UART</td> <td>1</td> <td>1</td> </tr> </tbody> </table>	Mode	Description	<i>SM0</i>	<i>SM1</i>	0	N/A	0	0	1	8-bit UART	0	1	2	9-bit UART	1	0	3	9-bit UART	1	1
Mode	Description		<i>SM0</i>	<i>SM1</i>																		
0	N/A		0	0																		
1	8-bit UART		0	1																		
2	9-bit UART	1	0																			
3	9-bit UART	1	1																			
<i>S0CON[6]</i>	<i>SM1</i>																					
<i>S0CON[5]</i>	<i>SM20</i>	Enables the inter-processor communication feature.																				
<i>S0CON[4]</i>	<i>REN0</i>	If set, enables serial reception. Cleared by software to disable reception.																				
<i>S0CON[3]</i>	<i>TB80</i>	The 9 th transmitted data bit in Modes 2 and 3. Set or cleared by the MPU, depending on the function it performs (parity check, multiprocessor communication etc.)																				
<i>S0CON[2]</i>	<i>RB80</i>	In Modes 2 and 3 it is the 9 th data bit received. In Mode 1, <i>SM20</i> is 0, <i>RB80</i> is the stop bit. In mode 0, this bit is not used. Must be cleared by software.																				
<i>S0CON[1]</i>	<i>TI0</i>	Transmit interrupt flag; set by hardware after completion of a serial transfer. Must be cleared by software.																				
<i>S0CON[0]</i>	<i>RI0</i>	Receive interrupt flag; set by hardware after completion of a serial reception. Must be cleared by software.																				

Table 18: The *S1CON* (UART1) register (SFR 0x9B)

Bit	Symbol	Function												
<i>S1CON[7]</i>	<i>SM</i>	Sets the baud rate and mode for UART1. <table border="1" style="margin-left: 20px;"> <thead> <tr> <th><i>SM</i></th> <th>Mode</th> <th>Description</th> <th>Baud Rate</th> </tr> </thead> <tbody> <tr> <td>0</td> <td>A</td> <td>9-bit UART</td> <td>variable</td> </tr> <tr> <td>1</td> <td>B</td> <td>8-bit UART</td> <td>variable</td> </tr> </tbody> </table>	<i>SM</i>	Mode	Description	Baud Rate	0	A	9-bit UART	variable	1	B	8-bit UART	variable
<i>SM</i>	Mode	Description	Baud Rate											
0	A	9-bit UART	variable											
1	B	8-bit UART	variable											
<i>S1CON[5]</i>	<i>SM21</i>	Enables the inter-processor communication feature.												
<i>S1CON[4]</i>	<i>REN1</i>	If set, enables serial reception. Cleared by software to disable reception.												
<i>S1CON[3]</i>	<i>TB81</i>	The 9 th transmitted data bit in Mode A. Set or cleared by the MPU, depending on the function it performs (parity check, multiprocessor communication etc.)												

Bit	Symbol	Function
<i>SICON[2]</i>	<i>RB81</i>	In Modes A and B, it is the 9 th data bit received. In Mode B, if <i>SM21</i> is 0, <i>RB81</i> is the stop bit. Must be cleared by software
<i>SICON[1]</i>	<i>TII</i>	Transmit interrupt flag, set by hardware after completion of a serial transfer. Must be cleared by software.
<i>SICON[0]</i>	<i>RII</i>	Receive interrupt flag, set by hardware after completion of a serial reception. Must be cleared by software.

Table 19: *PCON* Register Bit Description (SFR 0x87)

Bit	Symbol	Function
<i>PCON[7]</i>	<i>SMOD</i>	The <i>SMOD</i> bit doubles the baud rate when set
<i>PCON[6:2]</i>	–	Not used.
<i>PCON[1]</i>	<i>STOP</i>	Stops MPU flash access and MPU peripherals including timers and UARTs when set until an external interrupt is received.
<i>PCON[0]</i>	<i>IDLE</i>	Stops MPU flash access when set until an internal interrupt is received.

1.4.7 Timers and Counters

The 80515 has two 16-bit timer/counter registers: Timer 0 and Timer 1. These registers can be configured for counter or timer operations.

In timer mode, the register is incremented every 12 MPU clock cycles. In counter mode, the register is incremented when the falling edge is observed at the corresponding input signal T0 or T1 (T0 and T1 are the timer gating inputs derived from certain DIO pins, see Section 1.5.7 Digital I/O). Since it takes 2 machine cycles to recognize a 1-to-0 event, the maximum input count rate is 1/2 of the clock frequency (CKMPU). There are no restrictions on the duty cycle, however to ensure proper recognition of the 0 or 1 state, an input should be stable for at least 1 machine cycle.

Four operating modes can be selected for Timer 0 and Timer 1, as shown in Table 20 and Table 21. The *TMOD* Register, shown in Table 22, is used to select the appropriate mode. The timer/counter operation is controlled by the *TCON* Register, which is shown in Table 23. Bits *TR1* (*TCON[6]*) and *TR0* (*TCON[4]*) in the *TCON* register start their associated timers when set.

Table 20: Timers/Counters Mode Description

M1	M0	Mode	Function
0	0	Mode 0	13-bit Counter/Timer mode with 5 lower bits in the <i>TL0</i> or <i>TL1</i> register and the remaining 8 bits in the <i>TH0</i> or <i>TH1</i> register (for Timer 0 and Timer 1, respectively). The 3 high order bits of <i>TL0</i> and <i>TL1</i> are held at zero.
0	1	Mode 1	16-bit Counter/Timer mode.
1	0	Mode 2	8-bit auto-reload Counter/Timer. The reload value is kept in <i>TH0</i> or <i>TH1</i> , while <i>TL0</i> or <i>TL1</i> is incremented every machine cycle. When <i>TL(x)</i> overflows, a value from <i>TH(x)</i> is copied to <i>TL(x)</i> (where x = 0 for counter/timer 0 or 1 for counter/timer 1).
1	1	Mode 3	If Timer 1 <i>M1</i> and <i>M0</i> bits are set to 1, Timer 1 stops. If Timer 0 <i>M1</i> and <i>M0</i> bits are set to 1, Timer 0 acts as two independent 8-bit Timer/Counters.

- In Mode 3, *TL0* is affected by *TR0* and gate control bits and sets the *TF0* flag on overflow, while *TH0* is affected by the *TR1* bit and the *TF1* flag is set on overflow.

Table 21 specifies the combinations of operation modes allowed for Timer 0 and Timer 1.

Table 21: Allowed Timer/Counter Mode Combinations

	Timer 1		
	Mode 0	Mode 1	Mode 2
Timer 0 - mode 0	Yes	Yes	Yes
Timer 0 - mode 1	Yes	Yes	Yes
Timer 0 - mode 2	Not allowed	Not allowed	Yes

Table 22: TMOD Register Bit Description (SFR 0x89)

Bit	Symbol	Function
Timer/Counter 1:		
<i>TMOD[7]</i>	<i>Gate</i>	If <i>TMOD[7]</i> is set, external input signal control is enabled for Counter 0. external gate control. The <i>TR1</i> bit in the <i>TCON</i> register (SFR 0x88) must also be set in order for Counter 1 to increment. With these settings Counter 1 is incremented on every falling edge of the logic signal applied to one or more of the interrupt sources controlled by the <i>DI_RBP</i> , <i>DIO_R1</i> , ... <i>DIO_RXX</i> registers.
<i>TMOD[6]</i>	<i>C/T</i>	Selects timer or counter operation. When set to 1, a counter operation is performed. When cleared to 0, the corresponding register will function as a timer.
<i>TMOD[5:4]</i>	<i>M1:M0</i>	Selects the mode for Timer/Counter 1 as shown in Table 20 .
Timer/Counter 0:		
<i>TMOD[3]</i>	<i>Gate</i>	If <i>TMOD[3]</i> is set, external input signal control is enabled for Counter 0. external gate control. The <i>TR0</i> bit in the <i>TCON</i> register (SFR 0x88) must also be set in order for Counter 0 to increment. With these settings Counter 0 is incremented on every falling edge of the logic signal applied to one or more of the interrupt sources controlled by the <i>DI_RBP</i> , <i>DIO_R1</i> , ... <i>DIO_RXX</i> registers.
<i>TMOD[2]</i>	<i>C/T</i>	Selects timer or counter operation. When set to 1, a counter operation is performed. When cleared to 0, the corresponding register will function as a timer.
<i>TMOD[1:0]</i>	<i>M1:M0</i>	Selects the mode for Timer/Counter 0, as shown in Table 20 .

Table 23: The TCON Register Bit Functions (SFR 0x88)

Bit	Symbol	Function
<i>TCON[7]</i>	<i>TF1</i>	The Timer 1 overflow flag is set by hardware when Timer 1 overflows. This flag can be cleared by software and is automatically cleared when an interrupt is processed.
<i>TCON[6]</i>	<i>TR1</i>	Timer 1 run control bit. If cleared, Timer 1 stops.
<i>TCON[5]</i>	<i>TF0</i>	Timer 0 overflow flag set by hardware when Timer 0 overflows. This flag can be cleared by software and is automatically cleared when an interrupt is processed.
<i>TCON[4]</i>	<i>TR0</i>	Timer 0 Run control bit. If cleared, Timer 0 stops.
<i>TCON[3]</i>	<i>IE1</i>	Interrupt 1 edge flag is set by hardware when the falling edge on external pin int1 is observed. Cleared when an interrupt is processed.
<i>TCON[2]</i>	<i>IT1</i>	Interrupt 1 type control bit. Selects either the falling edge or low level on input pin to cause an interrupt.
<i>TCON[1]</i>	<i>IE0</i>	Interrupt 0 edge flag is set by hardware when the falling edge on external pin int0 is observed. Cleared when an interrupt is processed.
<i>TCON[0]</i>	<i>IT0</i>	Interrupt 0 type control bit. Selects either the falling edge or low level on input pin to cause interrupt.

1.4.8 WD Timer (Software Watchdog Timer)

There is no internal software watchdog timer. Use the standard watchdog timer instead (see [1.5.16 Hardware Watchdog Timer](#)).

1.4.9 Interrupts

The 80515 MPU provides 11 interrupt sources with four priority levels. Each source has its own request flag(s) located in a special function register (*TCON*, *IRCON* and *SCON*). Each interrupt requested by the corresponding flag can be individually enabled or disabled by the enable bits in SFRs *IEN0* (SFR 0xA8), *IEN1* (SFR 0xB8), and *IEN2* (SFR 0x9A). [Figure 8](#) shows the device interrupt structure.

Referring to [Figure 8](#), interrupt sources can originate from within the 80515 MPU core (referred to as Internal Sources) or can originate from other parts of the 71M653x SoC (referred to as External Sources). There are seven external interrupt sources, as seen in the leftmost part of [Figure 8](#), and in [Table 24](#) and [Table 25](#) (i.e., *EX0-EX6*).

Interrupt Overview

When an interrupt occurs, the MPU will vector to the predetermined address as shown in [Table 36](#). Once the interrupt service has begun, it can be interrupted only by a higher priority interrupt. The interrupt service is terminated by a return from instruction, RETI. When an RETI is performed, the processor will return to the instruction that would have been next when the interrupt occurred.

When the interrupt condition occurs, the processor will also indicate this by setting a flag bit. This bit is set regardless of whether the interrupt is enabled or disabled. Each interrupt flag is sampled once per machine cycle, after that, samples are polled by the hardware. If the sample indicates a pending interrupt when the interrupt is enabled, then the interrupt request flag is set. On the next instruction cycle, the interrupt will be acknowledged by hardware forcing an LCALL to the appropriate vector address, if the following conditions are met:

- No interrupt of equal or higher priority is already in progress.
- An instruction is currently being executed and is not completed.
- The instruction in progress is not RETI or any write access to the registers *IEN0*, *IEN1*, *IEN2*, *IP0* or *IP1*.

Special Function Registers for Interrupts

The following SFR registers control the interrupt functions:

- The interrupt enable registers: *IEN0*, *IEN1* and *IEN2* (see [Table 24](#), [Table 25](#) and [Table 26](#)).
- The Timer/Counter control registers, *TCON* and *T2CON* (see [Table 27](#) and [Table 28](#)).
- The interrupt request register, *IRCON* (see [Table 29](#)).
- The interrupt priority registers: *IP0* and *IP1* (see [Table 34](#)).

Table 24: The *IEN0* Bit Functions (SFR 0xA8)

Bit	Symbol	Function
<i>IEN0</i> [7]	<i>EAL</i>	<i>EAL</i> = 0 disables all interrupts.
<i>IEN0</i> [6]	<i>WDT</i>	Not used for interrupt control.
<i>IEN0</i> [5]	–	Not Used.
<i>IEN0</i> [4]	<i>ES0</i>	<i>ES0</i> = 0 disables serial channel 0 interrupt.
<i>IEN0</i> [3]	<i>ET1</i>	<i>ET1</i> = 0 disables timer 1 overflow interrupt.
<i>IEN0</i> [2]	<i>EX1</i>	<i>EX1</i> = 0 disables external interrupt 1.
<i>IEN0</i> [1]	<i>ET0</i>	<i>ET0</i> = 0 disables timer 0 overflow interrupt.
<i>IEN0</i> [0]	<i>EX0</i>	<i>EX0</i> = 0 disables external interrupt 0.

Table 25: The IEN1 Bit Functions (SFR 0xB8)

Bit	Symbol	Function
<i>IEN1[7]</i>	–	Not used.
<i>IEN1[6]</i>	–	Not used.
<i>IEN1[5]</i>	<i>EX6</i>	<i>EX6</i> = 0 disables external interrupt 6: XFER_BUSY, RTC_1SEC, WD_NROVF
<i>IEN1[4]</i>	<i>EX5</i>	<i>EX5</i> = 0 disables external interrupt 5: EEPROM_BUSY
<i>IEN1[3]</i>	<i>EX4</i>	<i>EX4</i> = 0 disables external interrupt 4: PLL_OK (rise), PLL_OK (fall)
<i>IEN1[2]</i>	<i>EX3</i>	<i>EX3</i> = 0 disables external interrupt 3: CE_BUSY
<i>IEN1[1]</i>	<i>EX2</i>	<i>EX2</i> = 0 disables external interrupt 2: FWCOL0, FWCOL1, SPI
<i>IEN1[0]</i>	–	Not Used.

Table 26: The IEN2 Bit Functions (SFR 0x9A)

Bit	Symbol	Function
<i>IEN2[0]</i>	<i>ESI</i>	<i>ESI</i> = 0 disables the serial channel 1 interrupt.

Table 27: TCON Bit Functions (SFR 0x88)

Bit	Symbol	Function
<i>TCON[7]</i>	<i>TF1</i>	Timer 1 overflow flag.
<i>TCON[6]</i>	<i>TR1</i>	Not used for interrupt control.
<i>TCON[5]</i>	<i>TF0</i>	Timer 0 overflow flag.
<i>TCON[4]</i>	<i>TR0</i>	Not used for interrupt control.
<i>TCON[3]</i>	<i>IE1</i>	External interrupt 1 flag.
<i>TCON[2]</i>	<i>IT1</i>	External interrupt 1 type control bit: 0 = interrupt on low level. 1 = interrupt on falling edge.
<i>TCON[1]</i>	<i>IE0</i>	External interrupt 0 flag
<i>TCON[0]</i>	<i>IT0</i>	External interrupt 0 type control bit: 0 = interrupt on low level. 1 = interrupt on falling edge.

Table 28: The T2CON Bit Functions (SFR 0xC8)

Bit	Symbol	Function
<i>T2CON[7]</i>	–	Not used.
<i>T2CON[6]</i>	<i>I3FR</i>	Polarity control for external interrupt 3: CE_BUSY 0 = falling edge. 1 = rising edge.
<i>T2CON[5]</i>	<i>I2FR</i>	Polarity control for external interrupt 2: FWCOL0, FWCOL1, SPI 0 = falling edge. 1 = rising edge.
<i>T2CON[4:0]</i>	–	Not used.

Table 29: The IRCON Bit Functions (SFR 0xC0)

Bit	Symbol	Function
<i>IRCON[7]</i>	–	Not used
<i>IRCON[6]</i>	–	Not used
<i>IRCON[5]</i>	<i>IEX6</i>	1 = External interrupt 6 occurred and has not been cleared.
<i>IRCON[4]</i>	<i>IEX5</i>	1 = External interrupt 5 occurred and has not been cleared.
<i>IRCON[3]</i>	<i>IEX4</i>	1 = External interrupt 4 occurred and has not been cleared.
<i>IRCON[2]</i>	<i>IEX3</i>	1 = External interrupt 3 occurred and has not been cleared.

<i>IRCON</i> [1]	<i>IEX2</i>	1 = External interrupt 2 occurred and has not been cleared.
<i>IRCON</i> [0]	–	Not used.

- TF0* and *TF1* (Timer 0 and Timer 1 overflow flags) will be automatically cleared by hardware when the service routine is called (Signals T0ACK and T1ACK – port ISR – active high when the service routine is called).

External MPU Interrupts

The seven external interrupts are the interrupts external to the 80515 core, i.e. signals that originate in other parts of the 71M6531D/F or 71M6532D/F, for example the CE, DIO, RTC or EEPROM interface.

The external interrupts are connected as described in [Table 30](#). The polarity of interrupts 2 and 3 is programmable in the MPU via the *I3FR* and *I2FR* bits in *T2CON* (*SFR 0xC8*). Interrupts 2 and 3 should be programmed for falling sensitivity (*I3FR* = *I2FR* = 0). The generic 8051 MPU literature states that interrupts 4 through 6 are defined as rising-edge sensitive. Thus, the hardware signals attached to interrupts 5 and 6 are inverted to achieve the edge polarity shown in [Table 30](#).

Table 30: External MPU Interrupts

External Interrupt	Connection	Polarity	Flag Reset
0	Digital I/O High Priority	see Section 1.5.7	automatic
1	Digital I/O Low Priority	see Section 1.5.7	automatic
2	FWCOL0, FWCOL1, SPI	falling	automatic
3	CE_BUSY	falling	automatic
4	PLL_OK (rising), PLL_OK (falling)	rising	automatic
5	EEPROM busy	falling	automatic
6	XFER_BUSY, RTC_1SEC or WD_NROVF	falling	manual

External interrupt 0 and 1 can be mapped to pins on the device using DIO resource maps. See Section [1.5.7 Digital I/O](#) for more information.

FWCOLx interrupts occur when the CE collides with a flash write attempt. See the Flash Write description in the [Flash Memory](#) section for more detail.

SFR enable bits must be set to permit any of these interrupts to occur. Likewise, each interrupt has its own flag bit, which is set by the interrupt hardware, and reset by the MPU interrupt handler. XFER_BUSY, RTC_1SEC, WD_NROVF, FWCOL0, FWCOL1, SPI, PLLRISE and PLLFALL have their own enable and flag bits in addition to the interrupt 6, 4 and enable and flag bits (see [Table 31](#)).

IE0 through IEX6 are cleared automatically when the hardware vectors to the interrupt handler. The other flags, IE_XFER through IE_PB, are cleared by writing a zero to them.



Since these bits are in an SFR bit addressable byte, common practice would be to clear them with a bit operation, but this must be avoided. The hardware implements bit operations as a byte-wide read-modify-write hardware macro. If an interrupt occurs after the read, but before the write, its flag will be cleared unintentionally.

The proper way to clear the flag bits is to write a byte mask consisting of all ones except for a zero in the location of the bit to be cleared. The flag bits are configured in hardware to ignore ones written to them.

Table 31: Interrupt Enable and Flag Bits

Interrupt Enable		Interrupt Flag		Interrupt Description
Name	Location	Name	Location	
<i>EX0</i>	SFR A8[0]	<i>IE0</i>	SFR 88[1]	External interrupt 0
<i>EX1</i>	SFR A8[2]	<i>IE1</i>	SFR 88[3]	External interrupt 1
<i>EX2</i>	SFR B8[1]	<i>IEX2</i>	SFR C0[1]	External interrupt 2
<i>EX3</i>	SFR B8[2]	<i>IEX3</i>	SFR C0[2]	External interrupt 3

Interrupt Enable		Interrupt Flag		Interrupt Description
Name	Location	Name	Location	
<i>EX4</i>	SFR B8[3]	<i>IEX4</i>	SFR C0[3]	External interrupt 4
<i>EX5</i>	SFR B8[4]	<i>IEX5</i>	SFR C0[4]	External interrupt 5
<i>EX6</i>	SFR B8[5]	<i>IEX6</i>	SFR C0[5]	External interrupt 6
<i>EX_XFER</i>	2002[0]	<i>IE_XFER</i>	SFR E8[0]	XFER_BUSY interrupt (INT 6)
<i>EX_RTC</i>	2002[1]	<i>IE_RTC</i>	SFR E8[1]	RTC_1SEC interrupt (INT 6)
<i>IEN_WD_NROVF</i>	20B0[0]	<i>WD_NROVF_FLAG</i>	20B1[0]	WDT near overflow (INT 6)
<i>IEN_SPI</i>	20B0[4]	<i>SPI_FLAG</i>	20B1[4]	SPI Interface (INT2)
<i>EX_FWCOL</i>	2007[4]	<i>IE_FWCOL0</i>	SFR E8[3]	FWCOL0 interrupt (INT 2)
		<i>IE_FWCOL1</i>	SFR E8[2]	FWCOL1 interrupt (INT 2)
<i>EX_PLL</i>	2007[5]	<i>IE_PLLRISE</i>	SFR E8[6]	PLL_OK rise interrupt (INT 4)
		<i>IE_PLLFALL</i>	SFR E8[7]	PLL_OK fall interrupt (INT 4)
		<i>IE_WAKE</i>	SFR E8[5]	AUTOWAKE flag [†]
		<i>IE_PB</i>	SFR E8[4]	PB flag [†]

[†] The *AUTOWAKE* and *PB* flag bits are shown in [Table 31](#) because they behave similarly to interrupt flags, even though they are not actually related to an interrupt. These bits are set by hardware when the MPU wakes from a push button or wake timeout. The bits are reset by writing a zero. Note that the *PB* flag is set whenever the *PB* is pushed, even if the part is already awake.

WD_NROVF_FLAG is set approximately 1 ms before a WDT reset occurs. The flag can be cleared by writing a zero to it and is automatically cleared by the falling edge of *WAKE*.

Interrupt Priority Level Structure

All interrupt sources are combined in groups, as shown in [Table 32](#):

Table 32: Interrupt Priority Level Groups

Group	Group Members
0	External interrupt 0, Serial channel 1 interrupt
1	Timer 0 interrupt, External interrupt 2
2	External interrupt 1, External interrupt 3
3	Timer 1 interrupt, External interrupt 4
4	Serial channel 0 interrupt, External interrupt 5
5	External interrupt 6

Each group of interrupt sources can be programmed individually to one of four priority levels (as shown in [Table 33](#)) by setting or clearing one bit in the SFR interrupt priority register *IP0* and one in *IP1* ([Table 34](#)). If requests of the same priority level are received simultaneously, an internal polling sequence as shown in [Table 35](#) determines which request is serviced first.

- Changing interrupt priorities while interrupts are enabled can easily cause software defects. It is best to set the interrupt priority registers only once during initialization before interrupts are enabled.

Table 33: Interrupt Priority Levels

<i>IPI[x]</i>	<i>IP0[x]</i>	Priority Level
0	0	Level 0 (lowest)
0	1	Level 1
1	0	Level 2
1	1	Level 3 (highest)

Table 34: Interrupt Priority Registers (*IP0* and *IP1*)

Register	Address	Bit 7 (MSB)	Bit 6	Bit 5	Bit 4	Bit 3	Bit 2	Bit 1	Bit 0 (LSB)
<i>IP0</i>	SFR 0xA9	–	–	<i>IP0</i> [5]	<i>IP0</i> [4]	<i>IP0</i> [3]	<i>IP0</i> [2]	<i>IP0</i> [1]	<i>IP0</i> [0]
<i>IP1</i>	SFR 0xB9	–	–	<i>IP1</i> [5]	<i>IP1</i> [4]	<i>IP1</i> [3]	<i>IP1</i> [2]	<i>IP1</i> [1]	<i>IP1</i> [0]

Table 35: Interrupt Polling Sequence

External interrupt 0	↓ Polling sequence
Serial channel 1 interrupt	
Timer 0 interrupt	
External interrupt 2	
External interrupt 1	
External interrupt 3	
Timer 1 interrupt	
External interrupt 4	
Serial channel 0 interrupt	
External interrupt 5	
External interrupt 6	

Interrupt Sources and Vectors

Table 36 shows the interrupts with their associated flags and vector addresses.

Table 36: Interrupt Vectors

Interrupt Request Flag	Description	Interrupt Vector Address
<i>IE0</i>	External interrupt 0	0x0003
<i>TF0</i>	Timer 0 interrupt	0x000B
<i>IE1</i>	External interrupt 1	0x0013
<i>TF1</i>	Timer 1 interrupt	0x001B
<i>RI0/TI0</i>	Serial channel 0 interrupt	0x0023
<i>RI1/TI1</i>	Serial channel 1 interrupt	0x0083
<i>IEX2</i>	External interrupt 2	0x004B
<i>IEX3</i>	External interrupt 3	0x0053
<i>IEX4</i>	External interrupt 4	0x005B
<i>IEX5</i>	External interrupt 5	0x0063
<i>IEX6</i>	External interrupt 6	0x006B

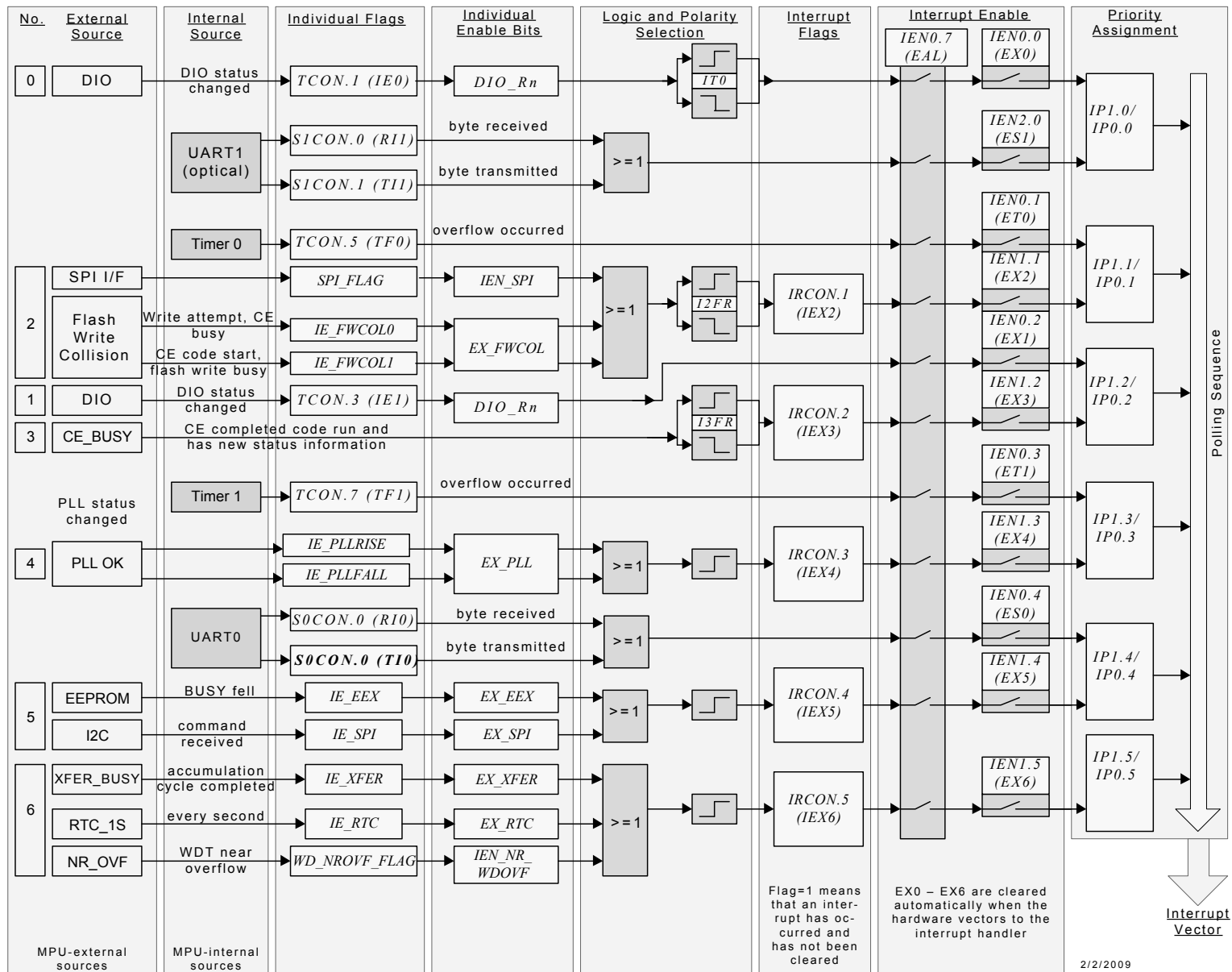

Figure 8: Interrupt Structure

1.5 On-Chip Resources

1.5.1 Oscillator

The oscillator of the 71M6531D/F and 71M6532D/F drives a standard 32.768 kHz watch crystal. These crystals are accurate and do not require a high-current oscillator circuit. The oscillator of the 71M6531D/F and 71M6532D/F has been designed specifically to handle these crystals and is compatible with their high impedance and limited power handling capability.

Oscillator calibration can improve the accuracy of both the RTC and metering. Refer to Section [1.5.3 Real-Time Clock \(RTC\)](#) for more information.

The oscillator is powered directly and only from VBAT, which therefore must be connected to a DC voltage source. The oscillator requires approximately 100 nA, which is negligible compared to the internal leakage of a battery.

The oscillator may appear to work when VBAT is not connected, but this mode of operation is not recommended.



If VBAT is connected to a drained battery or disconnected, a battery test that sets BME may drain VBAT's supply and cause the oscillator to stop. A stopped oscillator may force the device to reset. Therefore, an unexpected reset during a battery test should be interpreted as a battery failure.

1.5.2 Internal Clocks

Timing for the device is derived from the 32.768 kHz crystal oscillator output. On-chip timing functions include:

- The MPU clock (CKMPU)
- The emulator clock (2 x CKMPU)
- The clock for the CE (CKCE)
- The clock driving the delta-sigma ADC along with the FIR (CKADC, CKFIR)
- A real time clock (RTC).

The two general-purpose counter/timers contained in the MPU are controlled by CKMPU (see Section [1.4.7 Timers and Counters](#)). [Table 37](#) provides a summary of the available clock functions.

Table 37: Clock System Summary

Clock	Derived From	MCK Divider / [M40MHZ, M26MHZ]			Brownout Mode	
		÷2 / [1,0]	÷3 / [0,1]	÷4 ^{**} / [0,0]		
CKPLL	Crystal	78.6432 MHz	78.6432 MHz	78.6432 MHz	off	
MCK	CKPLL	39.3216 MHz	26.2144 MHz	19.6608 MHz	112 kHz	
CKCE	MCK	4.9152 MHz [†]	9.8304 MHz [†]	6.5536MHz	4.9152 MHz	off
CKADC / CKFIR	MCK	4.9152 MHz	6.5536 MHz	4.9152 MHz	28 kHz	
CKMPU maximum	MCK	9.8304 MHz ^{***}	6.5536 MHz ^{***}	4.9152 MHz ^{***}	28 kHz	
CK32	MCK	32.768 kHz	32.768 kHz	32.768 kHz		

^{**} Default state at power-up
^{***} The maximum CKMPU frequency. CKMPU can be reduced from this rate using *MPU_DIV[2:0]*.
[†] CKCE = 9.8304 MHz when *CE10MHZ* is set, 4.9152 MHz otherwise.

The master clock, MCK, is generated by an on-chip PLL that multiplies the oscillator output frequency (CK32) by 2400 to provide approximately 80 MHz (78.6432 MHz). A divider controlled by the I/O RAM bits *M40MHZ* and *M26MHZ* permits scaling of MCK by ½, ⅓ and ¼. All other clocks are derived from this scaled MCK output (making them multiples of 32768 Hz), and the clock skew is matched so that the rising edges of CKADC, CKCE, CK32 and CKMPU are aligned.

The PLL generates a 2x emulator clock which is controlled by the *ECK_DIS* bit. Since clock noise from this feature may disturb the ADC, it is recommended that this option be avoided when possible.

The MPU clock frequency CKMPU is determined by another divider controlled by the I/O RAM field *MPU_DIV[2:0]* and can be set to $MCK/2^{(MPU_DIV+2)}$ Hz where *MPU_DIV[2:0]* varies from 0 to 6. The circuit also generates the 2 x CKMPU clock for use by the emulator. The emulator clock is not generated when *ECK_DIS* is asserted.

During a power-on reset, [*M40MHZ*, *M26MHZ*] defaults to [0,0] and the MCK divider is set to divide by 4. When [*M40MHZ*, *M26MHZ*] = [1,0], the CE clock frequency may be set to ~5 MHz (4.9152 MHz) or ~10 MHz (9.8304 MHz), using the I/O RAM register *CE10MHZ*. In this mode, the ADC and FIR clock frequencies remain at ~ 5 MHz. When [*M40MHZ*, *M26MHZ*] = [0,1], the CE, ADC, FIR and MPU clock frequencies are shifted to ~ 6.6 MHz (6.5536 MHz). This increases the ADC sample rate by 33%.



CE codes are tailored to particular CE clock frequencies. Changing the clock frequency for a particular CE code may render it unusable.

In SLEEP mode, the *M40MHZ* and *M26MHZ* inputs to the clock generator are forced low. In BROWNOUT mode, the clocks are derived from the crystal oscillator and the clock frequencies are scaled by 7/8.

1.5.3 Real-Time Clock (RTC)

The RTC is driven directly by the crystal oscillator. It is powered by the net *RTC_NV* (battery-backed up supply). The RTC consists of a counter chain and output registers. The counter chain consists of registers for seconds, minutes, hours, day of week, day of month, month and year. The RTC is capable of processing leap years. Each counter has its own output register. Whenever the MPU reads the seconds register, all other output registers are automatically updated. Since the RTC clock (RTCLK) is not coherent to the MPU clock, the MPU must read the seconds register until two consecutive reads are the same (this requires either 2 or 3 reads). At this point, all RTC output registers will have the correct time. Regardless of the MPU clock speed, RTC reads require one wait state.

RTC time is set by writing to the registers *RTC_SEC[5:0]* through *RTC_YR*. Each write operation must be preceded by a write operation to the *WE* register in I/O RAM. The value written to the *WE* register is unimportant.

Time adjustments are written to the *RTCA_ADJ[6:0]*, *PREG[16:0]* and *QREG[1:0]* registers. Updates to *PREG[16:0]* and *QREG[1:0]* must occur after the one second interrupt and must be finished before reaching the next one second boundary. The new values are loaded into the counters at the next one second boundary.

PREG[16:0] and *QREG[1:0]* are separate registers in the device hardware, but the bits are 16-bit contiguous so the MPU firmware can treat them as a single register. A single binary number can be calculated and then loaded into them at the same time.

The 71M6531D/F and 71M6532D/F have two rate adjustment mechanisms. The first is an analog rate adjustment, using *RTCA_ADJ[6:0]*, which trims the crystal load capacitance. Setting *RTCA_ADJ[6:0]* to 00 minimizes the load capacitance, maximizing the oscillator frequency. Setting *RTCA_ADJ[6:0]* to 0x3F maximizes the load capacitance, minimizing the oscillator frequency. The adjustable capacitance is approximately:

$$C_{ADJ} = \frac{RTCA_ADJ}{128} \cdot 16.5 pF$$

The maximum adjustment range is approximately -12 ppm to +22ppm. The precise amount of adjustment will depend on the crystal properties. The adjustment may occur at any time and the resulting clock frequency can be measured over a one-second interval.

The second rate adjustment is a digital rate adjust using *PREG[16:0]* and *QREG[1:0]*, which can be used to adjust the clock rate up to ± 988 ppm, with a resolution of 3.8 ppm. Updates must occur after a one second interrupt and must finish before the next one second boundary. The rate adjustment will be implemented starting at the next one second boundary. Since the LSB results in an adjustment every four seconds, the frequency should be measured over an interval that is a multiple of four seconds.

To adjust the clock rate using the digital rate adjust, the appropriate values must be written to $PREG[16:0]$ and $QREG[1:0]$. The default frequency is 32,768 RTCLK cycles per second. To shift the clock frequency by Δ ppm, calculate $PREG[16:0]$ and $QREG[1:0]$ using the following equation:

$$4 \cdot PREG + QREG = \text{floor} \left(\frac{32768 \cdot 8}{1 + \Delta \cdot 10^{-6}} + 0.5 \right)$$

For example, for a shift of -988 ppm, $4 \cdot PREG + QREG = 262403 = 0x40103$. $PREG[16:0] = 0x10040$ and $QREG[1:0] = 0x03$. The default values of $PREG[16:0]$ and $QREG[1:0]$, corresponding to zero adjustment, are $0x10000$ and $0x0$, respectively.

The RTC timing may be observed on the TMUXOUT pin by setting $TMUX[4:0]$ to $0x10$ or $0x11$.

- Default values for $RTCA_ADJ$, $PREG[16:0]$ and $QREG[1:0]$ should be nominal values, at the center of the adjustment range. Extreme values (zero for example) can cause incorrect operation.

If the crystal temperature coefficient is known, the MPU can integrate temperature and correct the RTC time as necessary.

Both $RTCA_ADJ[6:0]$ and $PREG[16:0]/QREG[1:0]$ are non-volatile registers, i.e. their values will be preserved in BROWNOUT, SLEEP and LCD modes. However, the digital correction controlled by the $PREG[16:0]/QREG[1:0]$ registers is not operational in SLEEP mode.

The digital adjustment using $PREG[16:0]$ and $QREG[1:0]$ is preferred over the analog adjustment using $RTCA_ADJ$. The digital adjustment is more repeatable and has a wider range.

The sub-second register of the RTC, $SUBSEC$, can be read by the MPU after the one second interrupt and before reaching the next one second boundary. $SUBSEC$ contains the count remaining, in $1/256$ second nominal clock periods, until the next one second boundary. When the RST_SUBSEC bit is written, the $SUBSEC$ counter is restarted. Reading and resetting the sub-second counter can be used as part of an algorithm to accurately set the RTC.

When setting the RTC_SEC register, it is important to take into account that the associated write operation will be performed only in the next second boundary. See Application Note AN4947 for details on RTC.

1.5.4 Temperature Sensor

The device includes an on-chip temperature sensor for determining the temperature of the bandgap reference. If automatic temperature measurement is not performed by selecting $CHOP_E[1:0] = 00$, the MPU may request an alternate multiplexer frame containing the temperature sensor output by asserting MUX_ALT . The primary use of the temperature data is to determine the magnitude of compensation required to offset the thermal drift in the system (see Section 3.4 Temperature Compensation).

1.5.5 Physical Memory

Flash Memory

The 71M6531D and 71M6532D include 128 KB of on-chip flash memory. The 71M6531F and 71M6532F offer 256 KB of flash memory. The flash memory primarily contains MPU and CE program code. It also contains images of the CE and MPU data in RAM, as well as of I/O RAM. On power-up, before enabling the CE, the MPU copies these images to their respective locations.

The flash memory is segmented into individually erasable pages that contain 1024 bytes.

Flash space allocated for the CE program is limited to 4096 16-bit words (8 KB). The CE program must begin on a 1-KB boundary of the flash address space. The $CE_LCTN[7:0]$ word defines which 1-KB boundary contains the CE code. Thus, the first CE instruction is located at $1024 \cdot CE_LCTN[7:0]$.

Flash Write Procedures

The MPU may write to the flash memory. This is one of the non-volatile storage options available to the user in addition to external EEPROM.

$FLSH_PWE$ (flash program write enable) differentiates 80515 data store instructions ($MOVX@DPTR,A$) between Flash and XRAM write operations. This bit must be cleared by the MPU after each byte write operation. Write operations to this bit are inhibited when interrupts are enabled.

The MPU cannot write to flash while the CE is executing its code from flash. Two interrupts warn of collisions between the MPU firmware and the CE timing. If a flash write operation is attempted while the CE is busy, the flash write will not execute and the FWCOL0 interrupt will be issued. If a flash write is still in progress when the CE would otherwise begin a code pass, the code pass is skipped, the write operation is completed, and the FWCOL1 interrupt is issued.

The simplest flash write procedure disables the CE during the write operation and interpolates the metering measurements. However, this results in the loss of at least one second of data, because the CE has to resynchronize with the mains voltage.

There is a brief guaranteed interval (typically 1/32768 s) between CE executions which occurs 2520 times per second. The start of the interval can be detected with the CE_BUSY interrupt which occurs on the falling edge of CE_BUSY (an internal signal measurable from TMUXOUT). However, this guaranteed idle time (30.5 μ s) is too short to write a byte which takes 42 μ s or to erase a page of flash memory which takes at least 20 ms. Some CE code has substantially longer idle times, but in those cases, firmware interrupt latencies can easily consume the available write time. If a flash write fails in this scheme, the failure can be detected with the FWCOL0 or FWCOL1 interrupt and the write can be retried.

It is practical to pre-erase pages, disable interrupts and poll the CE_BUSY interrupt flag, *IRCON[2]*. This method avoids problems with interrupt latency, but can still result in a write failure if the CE code takes too much time. As mentioned above, polling FWCOL0 and FWCOL1 can detect write failures. However, the speed in a polling write is only 2520 bytes per second and the firmware cannot respond to interrupts.

As an alternative to using flash, a small EEPROM can store data without compromises. EEPROM interfaces are included in the device.

Updating Individual Bytes in Flash Memory

The original state of a flash byte is 0xFF (all ones). Once a value other than 0xFF is written to a flash memory cell, overwriting with a different value usually requires that the cell be erased first. Since cells cannot be erased individually, the page has to be copied to RAM, followed by a page erase. After this, the page can be updated in RAM and then written back to the flash memory.

Flash Erase Procedures

Flash erasure is initiated by writing a specific data pattern to specific SFR registers in the proper sequence. These special pattern/sequence requirements prevent inadvertent erasure of the flash memory.

The mass erase sequence is:

1. Write 1 to the *FLSH_MEEN* bit (*SFR 0xB2[1]*).
2. Write pattern 0xAA to *FLSH_ERASE* (*SFR 0x94*).

The mass erase cycle can only be initiated when the ICE port is enabled.

The page erase sequence is:

1. Write the page address to *FLSH_PGADR[5:0]* (*SFR 0xB7[7:1]*).
2. Write pattern 0x55 to *FLSH_ERASE* (*SFR 0x94*).

Note: Transitions to BROWNOUT mode must be avoided during page erase operations.

Bank-Switching:

The program memory of the 71M6531 consists of a fixed lower bank of 32 KB addressable at 0x0000 to 0x7FFF plus an upper bank area of 32 KB, addressable at 0x8000 to 0xFFFF. The upper 32 KB space is banked using the I/O RAM *FL_BANK* register as follows:

- The 71M6531D provides 4 banks of 32 KB each selected by *FL_BANK[1:0]*. Note that when *FL_BANK[1:0] = 00*, the upper bank is the same as the lower bank.
- The 71M6531F and 71M6532D/F provide 8 banks of 32 KB each selected by *FL_BANK[2:0]*.

Table 38 illustrates the bank switching mechanism.

Table 38: Bank Switching with *FL_BANK[2:0]*

71M6531D <i>FL_BANK [1:0]</i>	71M653XF <i>FL_BANK [2:0]</i>	Address Range for Lower Bank (0x000-0x7FFF)	Address Range for Upper Bank (0x8000-0xFFFF)
000	000	0x0000-0x7FFF	0x0000-0x7FFF
001	001		0x8000-0xFFFF
010	010		0x10000-0x17FFF
011	011		0x18000-0x1FFFF
	100		0x20000-0x217FF
	101		0x28000-0x2FFFF
	110		0x30000-0x37FFF
	111		0x38000-0x3FFFF

Program Security

When enabled, the security feature limits the ICE to global flash erase operations only. All other ICE operations are blocked. This guarantees the security of the user's MPU and CE program code. Security should be enabled by MPU code that is executed during the pre-boot interval (60 CKMPU cycles before the primary boot sequence begins). Once security is enabled, the only way to disable it is to perform a global erase of the flash, followed by a chip reset.

The first 60 cycles of the MPU boot code are called the pre-boot phase because during this phase the ICE is inhibited. A read-only status bit, *PREBOOT*, identifies these cycles to the MPU. Upon completion of pre-boot, the ICE can be enabled and is permitted to take control of the MPU.

The security enable bit, *SECURE*, is reset whenever the chip is reset. Hardware associated with the bit permits only ones to be written to it. Thus, pre-boot code may set *SECURE* to enable the security feature but may not reset it. Once *SECURE* is set, the pre-boot code is protected and no external read of program code is possible.

Specifically, when *SECURE* is set, the following applies:

- The ICE is limited to bulk flash erase only.
- Page zero of flash memory, the preferred location for the user's pre-boot code, may not be page-erased by either MPU or ICE. Page zero may only be erased with global flash erase.
- Write operations to page zero, whether by MPU or ICE are inhibited.

MPU/CE RAM:

The 71M6531D/F and 71M6532D/F include 4 KB of static RAM memory on-chip (XRAM) plus 256-bytes of internal RAM in the MPU core. The 4 KB of static RAM are used for data storage for MPU and CE operations.

1.5.6 Optical Interface

The device includes an interface to implement an IR/optical port. The pin *OPT_TX* is designed to directly drive an external LED for transmitting data on an optical link. The pin *OPT_RX* has the same threshold as the RX pin, but can also be used to sense the input from an external photo detector used as the receiver for the optical link. *OPT_TX* and *OPT_RX* are connected to a dedicated UART port (UART1).

The *OPT_TX* and *OPT_RX* pins can be inverted with configuration bits *OPT_TXINV* and *OPT_RXINV*, respectively. Additionally, the *OPT_TX* output may be modulated at 38 kHz. Modulation is available when system power is present (i.e. not in BROWNOUT mode). The *OPT_TXMOD* bit enables modulation. Duty cycle is controlled by *OPT_FDC[1:0]*, which can select 50%, 25%, 12.5% and 6.25% duty cycle. 6.25% duty cycle means *OPT_TX* is low for 6.25% of the period. [Figure 9](#) illustrates the *OPT_TX* generator.

When not needed for the optical UART, the *OPT_TX* pin can alternatively be configured as DIO2, WPULSE, or VARPULSE. The configuration bits are *OPT_TXE[1:0]*. Likewise, *OPT_RX* can alternately be configured as DIO1. Its control is *OPT_RXDIS*.

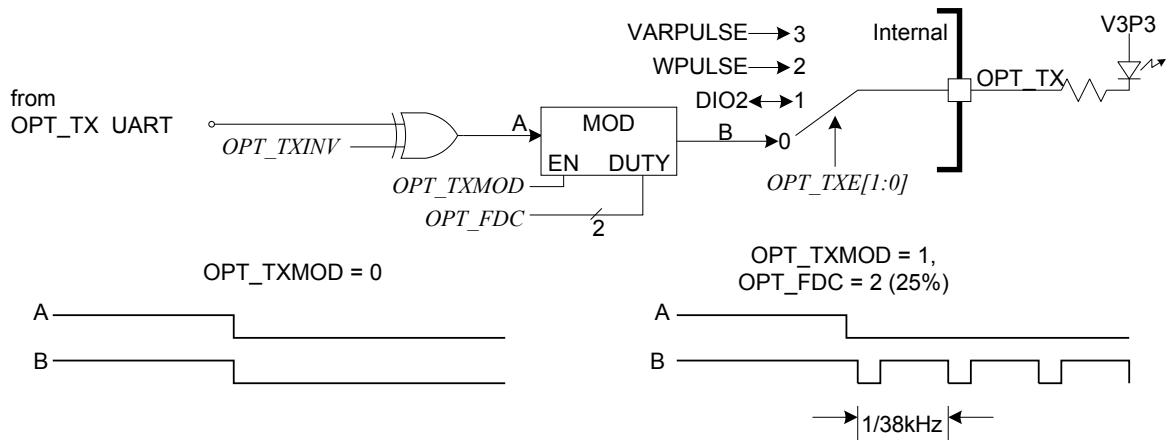

Figure 9: Optical Interface

1.5.7 Digital I/O – 71M6531D/F

The 71M6531D/F includes up to 22 pins of general-purpose digital I/O. These pins are compatible with 5 V inputs (no current limiting resistors are needed). The Digital I/O pins can be categorized as follows:

- Dedicated DIO pins (1 pin): PB
- DIO/LCD segment pins (a total of 19 pins):
 - DIO4/SEG24 - DIO15/SEG35 (12 pins)
 - DIO17/SEG37 (1 pin)
 - DIO28/SEG48 – DIO29/SEG49 (2 pins)
 - DIO43/SEG63 - DIO46/SEG66 (4 pins)
- DIO pins combined with other functions (2 pins): DIO2/OPT_TX, DIO1/OPT_RX

The pins DIO4/SEG24 through DIO46/SEG66 are configured by the *LCD_BITMAP* registers to be DIO or segment pins. A one in *LCD_BITMAP* defines the pin as a LCD segment output, a zero makes the pin a DIO pin. Pins configured as LCD pins are controlled with the *LCD_SEGnn* registers. Pins configured as DIO can be defined independently as an input or output with the *DIO_DIR* bits (see [Table 45](#)).

- Write operations to a disabled DIO are not ignored. Write operations are registered, but do not affect the pin, or the result of a read operation on the pin, until it becomes a DIO output.
- DIO2/OPT_TX will be an active TX output pin at power up (*OPT_TXE[1:0]* = 00).

A 3-bit configuration word, I/O RAM field *DIO_Rx[2:0]* (0x2009[2:0] through 0x200E[6:4]), can be used for certain pins (when configured as DIO) to individually assign an internal resource such as an interrupt or a timer control (see [Table 46](#) for DIO pins available for this option). This way, DIO pins can be tracked even if they are configured as outputs.

[Table 39](#) to [Table 41](#) lists the direction registers and configurability associated with each group of DIO pins.

Table 39: Data/Direction Registers and Internal Resources for DIO 1-15 (71M6531D/F)

DIO	PB	1	2	–	4	5	6	7	8	9	10	11	12	13	14	15
LCD Segment	–	–	–	–	24	25	26	27	28	29	30	31	32	33	34	35
Pin number	65	60	3	–	39	40	41	42	43	44	45	46	68	30	21	22
Configuration (DIO or LCD segment)	–	–	–	–	0	1	2	3	4	5	6	7	0	1	2	3
					<i>LCD_BITMAP[31:24]</i>								<i>LCD_BITMAP[39:32]</i>			
Data Register	0	1	2	–	4	5	6	7	0	1	2	3	4	5	6	7
	<i>DIO0 = P0 (SFR 0x80)</i>								<i>DIO1 = P1 (SFR 0x90)</i>							
Direction Register	–	1	2	–	4	5	6	7	0	1	2	3	4	5	6	7
	<i>DIO_DIR0 (SFR 0xA2)</i>								<i>DIO_DIR1 (SFR 0x91)</i>							
Internal Resources Configurable	–	–	–	–	Y	Y	Y	Y	Y	Y	Y	Y	–	–	–	–

Table 40: Data/Direction Registers and Internal Resources for DIO 17-29 (71M6531D/F)

DIO	–	17	–	–	–	–	–	–	–	–	–	–	28	29	–	–
LCD Segment	–	37	–	–	–	–	–	–	–	–	–	–	48	49	–	–
Pin number	–	13	–	–	–	–	–	–	–	–	–	–	47	24	–	–
Configuration (DIO or LCD segment)	–	5	–	–	–	–	–	–	–	–	–	–	0	1	–	–
	<i>LCD_BITMAP[39:32]</i>								<i>LCD_BITMAP[55:48]</i>							
Data Register	–	1	–	–	–	–	–	–	–	–	–	–	4	5	–	–
	<i>DIO2 = P2 (SFR 0xA0)</i>								<i>DIO3 = P3 (SFR 0xB0)</i>							
Direction Register 0 = input, 1 = output	–	1	–	–	–	–	–	–					<i>LCD_SEG48[3]</i>	<i>LCD_SEG49[3]</i>		
	<i>DIO_DIR2 (SFR 0xA1)</i>															

Table 41: Data/Direction Registers and Internal Resources for DIO 43-46 (71M6531D/F)

DIO	–	–	–	43	44	45	46	–
LCD Segment	–	–	–	63	64	65	66	–
Pin number	–	–	–	29	23	28	5	–
Configuration (DIO or LCD segment)	–	–	–	7	0	1	2	–
					<i>LCD_BITMAP[63:56]</i>		<i>LCD_BITMAP[64:71]</i>	
Data Register	–	–	–	<i>LCD_SEG63[0]</i>	<i>LCD_SEG64[0]</i>	<i>LCD_SEG65[0]</i>	<i>LCD_SEG66[0]</i>	–
Direction Register 0 = input, 1 = output	–	–	–	<i>LCD_SEG63[3]</i>	<i>LCD_SEG64[3]</i>	<i>LCD_SEG65[3]</i>	<i>LCD_SEG66[3]</i>	–

1.5.8 Digital I/O – 71M6532D/F

The 71M6532D/F includes up to 43 pins of general-purpose digital I/O. These pins are compatible with 5 V inputs (no current limiting resistors are needed). The Digital I/O pins can be categorized as follows:

- Dedicated DIO pins (4 pins):
 - DIO3
 - DIO56 – DIO58 (3 pins)
- DIO/LCD segment pins (a total of 37 pins):
 - DIO4/SEG24 – DIO27/SEG47 (24 pins)
 - DIO29/SEG49, DIO30/SEG50 (2 pins)
 - DIO40/SEG60 – DIO45/SEG65 (6 pins)
 - DIO47/SEG67 – DIO51/SEG71 (5 pins)
- DIO pins combined with other functions (2 pins): DIO2/OPT_TX, DIO1/OPT_RX

On reset or power-up, all DIO pins are inputs until they are configured for the desired direction under MPU control. The pin function can be configured by the I/O RAM bits *LCD_BITMAP_n*. Setting *LCD_BITMAP_n* = 1 configures the pin for LCD, setting *LCD_BITMAP_n* = 0 configures it for DIO. Once a pin is configured as DIO, it can be configured independently as an input or output with the *DIO_DIR* bits or the *LCD_SEG_n* registers. Input and output data are written to or read from the pins using SFR registers *P0*, *P1*, and *P2*. Table 42 to Table 44 shows the DIO pins with their configuration, direction control and data registers.

Table 42: Data/Direction Registers and Internal Resources for DIO 1-15 (71M6532D/F)

DIO	PB	1	2	3	4	5	6	7	8	9	10	11	12	13	14	15
LCD Segment	-	-	-	-	24	25	26	27	28	29	30	31	32	33	34	35
Pin number	92	87	3	17	60	61	62	63	67	68	69	70	100	44	29	30
Configuration (DIO or LCD segment)	Always DIO				0	1	2	3	4	5	6	7	0	1	2	3
									<i>LCD_BITMAP[31:24]</i>				<i>LCD_BITMAP[39:32]</i>			
Data Register	0	1	2	3	4	5	6	7	0	1	2	3	4	5	6	7
	<i>DIO0 = P0</i> (SFR 0x80)								<i>DIO1 = P1</i> (SFR 0x90)							
Direction Register 0 = input, 1 = output	-	1	2	3	4	5	6	7	0	1	2	3	4	5	6	7
	<i>DIO_DIR0</i> (SFR 0xA2)								<i>DIO_DIR1</i> (SFR 0x91)							
Internal Resources Configurable	Y	Y	Y	Y	Y	Y	Y	Y	Y	Y	Y	Y	-	-	-	-

Table 43: Data/Direction Registers and Internal Resources for DIO 16-30 (71M6532D/F)

DIO	16	17	18	19	20	21	22	23	24	25	26	27	-	29	30	-
LCD Segment	36	37	18	39	40	41	42	43	44	45	46	47	-	49	50	-
Pin number	33	12	13	64	65	66	93	54	46	43	42	41	-	32	35	
Configuration (DIO or LCD segment)	4	5	6	7	0	1	2	3	-	-	-	-	-	1	2	-
	<i>LCD_BITMAP[39:32]</i>				<i>LCD_BITMAP[47:40]</i>								<i>LCD_BITMAP[55:48]</i>			
Data Register	0	1	2	3	4	5	6	7	0	1	2	3	-	5	6	-
	<i>DIO2 = P2</i> (SFR 0xA0)								<i>DIO3 = P3</i> (SFR 0xB0)							
Direction Register 0 = input, 1 = output	-	1	-	3	4	5	-	-	-	-	-	-	-	-	-	-
	<i>DIO_DIR2</i> (SFR 0xA1)								-	-	-	-	-	<i>LCD_SEG49[3]</i>	<i>LCD_SEG50[3]</i>	-

Table 44: Data/Direction Registers and Internal Resources for DIO 40-51 (71M6532D/F)

DIO	40	41	42	43	44	45	–	47	48	49	50	51
LCD Segment	60	61	62	63	64	65	–	67	68	69	70	71
Pin number	95	97	98	40	31	38	–	22	23	24	25	50
Configuration (DIO or LCD segment)	4	5	6	7	0	1	–	3	4	5	6	7
	<i>LCD_BITMAP</i> [63:56]				<i>LCD_BITMAP</i> [71:64]							
Data Register	<i>LCD_SEG60</i> [0]	<i>LCD_SEG61</i> [0]	<i>LCD_SEG62</i> [0]	<i>LCD_SEG63</i> [0]	<i>LCD_SEG64</i> [0]	<i>LCD_SEG65</i> [0]	–	<i>LCD_SEG67</i> [0]	<i>LCD_SEG68</i> [0]	<i>LCD_SEG69</i> [0]	<i>LCD_SEG70</i> [0]	<i>LCD_SEG71</i> [0]
Direction Register 0 = input, 1 = output	<i>LCD_SEG60</i> [0]	<i>LCD_SEG61</i> [0]	<i>LCD_SEG62</i> [0]	<i>LCD_SEG63</i> [0]	<i>LCD_SEG64</i> [3]	<i>LCD_SEG65</i> [3]	–	<i>LCD_SEG67</i> [3]	<i>LCD_SEG68</i> [3]	<i>LCD_SEG69</i> [3]	<i>LCD_SEG70</i> [3]	<i>LCD_SEG71</i> [3]

DIO24 and higher do not have SFR registers for direction control. DIO40 and higher do not have SFR registers for data access. The direction control of these pins is achieved with the *LCD_SEGn*[3] bits and data access is controlled with the *LCD_SEGn*[0] bits in I/O RAM.

DIO56 through DIO58 are dedicated DIO pins. They are controlled with *DIO_DIR56*[7] through *DIO_DIR58*[7] and with *DIO_56*[4] through *DIO_58*[4] in I/O RAM.

1.5.9 Digital IO – Common Characteristics for 71M6531D/F and 71M6532D/F

On reset or power-up, all DIO pins are inputs until they are configured for the desired direction under MPU control. The pin function can be configured by the I/O RAM bits *LCD_BITMAPn*. Setting *LCD_BITMAPn* = 1 configures the pin for LCD, setting *LCD_BITMAPn* = 0 configures it for DIO. Once a pin is configured as DIO, it can be configured independently as an input or output with the *DIO_DIR* bits or the *LCD_SEGn* registers. Input and output data are written to or read from the pins using SFR registers *P0*, *P1*, and *P2*.

DIO24 and higher do not have SFR registers for direction control. DIO40 and higher do not have SFR registers for data access. The direction control of these pins is achieved with the *LCD_SEGn*[3] registers and data access is controlled with the *LCD_SEGn*[0] registers in I/O RAM.

- Since the control for DIO24 through DIO51 is shared with the control for LCD segments, the firmware must take care not to disturb the DIO pins when accessing the LCD segments and vice versa. Usually, this requires reading the I/O RAM register, applying a mask and writing back the modified byte.

Table 45: *DIO_DIR* Control Bit

	<i>DIO_DIR</i> [n]	
	0	1
DIO Pin n Function	Input	Output

Table 46: Selectable Control using *DIO_DIR* Bits

<i>DIO_R</i> Value	Resource Selected for DIO Pin
0	None
1	Reserved
2	T0 (counter 0 clock)
3	T1 (counter 1 clock)
4	High priority I/O interrupt (INT0 rising)
5	Low priority I/O interrupt (INT1 rising)
6	High priority I/O interrupt (INT0 falling)
7	Low priority I/O interrupt (INT1 falling)

Additionally, if DIO6 and DIO7 are configured as DIO and defined as outputs, they can be used as dedicated pulse outputs ($WPULSE = DIO6$, $VARPULSE = DIO7$) using the DIO_PW and DIO_PV bits. In this case, DIO6 and DIO7 are under CE control. DIO4 and DIO5 can be configured to implement the EEPROM Interface.

The PB pin is a dedicated digital input. In addition, if the optical UART is not used, OPT_TX and OPT_RX can be configured as dedicated DIO pins, DIO1 and DIO2, respectively (see Section 1.5.6 Optical Interface).

The internal control resources selectable for the DIO pins are listed in Table 46. If more than one input is connected to the same resource, the resources are combined using a logical OR.

 Tracking DIO pins configured as outputs is useful for pulse counting without external hardware. Either the interrupts or the counter/timer clocks can be used to count pulses on the pulse outputs or interrupts on the CE's power failure output.

 When driving LEDs, relay coils etc., the DIO pins should sink the current into GNDD (as shown in Figure 10, right), not source it from V3P3D (as shown in Figure 10, left). This is due to the resistance of the internal switch that connects V3P3D to either V3P3SYS or VBAT.



Sourcing current into or out of DIO pins other than the PB pin, for example with pull-up or pull-down resistors, should be avoided. Violating this rule will lead to increased quiescent current in SLEEP and LCD modes.

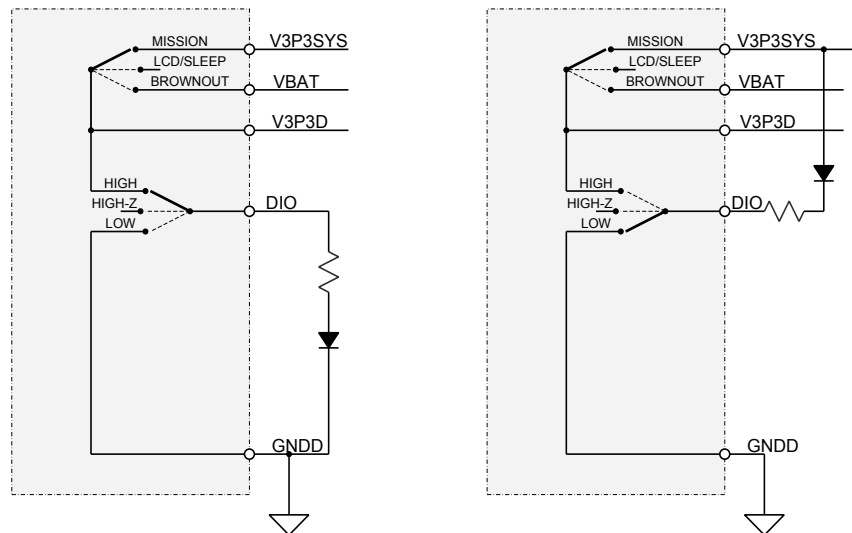

Figure 10: Connecting an External Load to DIO Pins

1.5.10 LCD Drivers – 71M6531D/F

The 71M6531 contains a total of 39 dedicated and multiplexed LCD drivers which are grouped as follows:

- 11 dedicated LCD segment drivers – always available
- 3 drivers multiplexed with the ICE interface (E_TCLK, E_RST, E_RXTX) – available in normal operation mode (when not emulating)
- 2 driver multiplexed with auxiliary signals MUX_SYNC and CKTEST (SEG7, SEG19) – available when not used for test
- 4 drivers multiplexed with the SPI port (PCLK, PSDO, PCSZ, PSDI)
- 19 multi-use pins described in Section 1.5.7 Digital I/O – 71M6531D/F.
- 4 common drivers for multiplexing (25%, 33%, 50%, or 100% duty cycle) – always available

With a minimum of 16 driver pins always available and a total of 39 driver pins in the maximum configuration, the device is capable of driving between 64 to 156 pixels of LCD display with 25% duty cycle. At eight pixels per digit, this corresponds to 8 to 19 digits. At 33% duty cycle, 48 to 117 pixels can be driven.

For each multi-use pin, the corresponding $LCD_BITMAP[]$ bit (see Section 1.5.7 Digital I/O – 71M6531D/F), is used to select the pin for DIO or LCD operation. The mapping of the $LCD_BITMAP[]$ bits is specified in

Section 4.1 I/O RAM and SFR Map – Functional Order. The LCD drivers are supported by the four common pins (COM0 – COM3).

1.5.11 LCD Drivers – 71M6532D/F

The 71M6532D/F contains a total of 67 dedicated and multiplexed LCD drivers, which are grouped as follows:

- 15 dedicated LCD segment drivers (SEG0 to SEG2, SEG8, SEG12 - SEG18, SEG20 – SEG23)
- 4 drivers multiplexed with the SPI port (SEG3 to SEG6)
- 2 drivers multiplexed with MUX_SYNC (SEG7) or CKTEST (SEG19)
- 3 drivers multiplexed with the ICE interface (SEG9 to SEG11)
- 43 multi-use LCD/DIO pins described in Section 1.5.8 Digital I/O – 71M6532D/F.

With a minimum of 15 driver pins always available and a total of 67 driver pins in the maximum configuration, the device is capable of driving between 60 to 268 pixels of an LCD display with 25% duty cycle. At eight pixels per digit, this corresponds to 7.5 to 33.5 digits.

For each multi-use pin, the corresponding *LCD_BITMAP[]* bit (see Section 1.5.8 Digital I/O – 71M6532D/F), is used to select the pin for DIO or LCD operation. The mapping of the *LCD_BITMAP[]* bits is specified in Section 4.1 I/O RAM and SFR Map – Functional Order. The LCD drivers are supported by the four common pins (COM0 – COM3).

1.5.12 LCD Drivers – Common Characteristics for 71M6531D/F and 71M6532D/F

The LCD interface is flexible and can drive 7-segment digits, 14-segment digits or enunciator symbols.

The LCD bias may be compensated for temperature using the *LCD_DAC[2:0]* bits in I/O RAM. The bias may be adjusted from 1.4 V below the 3.3 V supply (V3P3SYS in mission mode and BROWNOUT modes, VBAT in LCD mode). When the *LCD_DAC[2:0]* bits are set to 000, the DAC is bypassed and powered down. This can be used to reduce current in LCD mode.

Segment drivers SEG18 and SEG19 can be configured to blink at either 0.5 Hz or 1 Hz. The blink rate is controlled by *LCD_Y*. There can be up to four pixels/segments connected to each of these drivers. *LCD_BLKMAP18[3:0]* and *LCD_BLKMAP19[3:0]* identify which pixels, if any, are to blink. The most significant bit corresponds to COM3, the least significant to COM0.

1.5.13 Battery Monitor

The battery voltage is measured by the ADC during alternative MUX frames if the *BME* (Battery Measure Enable) bit is set. While *BME* is set, an on-chip 45 kΩ load resistor is applied to the battery and a scaled fraction of the battery voltage is applied to the ADC input. After each alternative MUX frame, the result of the ADC conversion is available at RAM address 0x0B. *BME* is ignored and assumed zero when system power is not available.

- If VBAT is connected to a drained battery or disconnected, a battery test that sets *BME* may drain VBAT's supply and cause the oscillator to stop. A stopped oscillator may force the device to reset. Therefore, an unexpected reset during a battery test should be interpreted as a battery failure.

Battery measurement is not very linear but is very reproducible if properly calibrated. The best way to perform the calibration is to set the battery input to the desired failure voltage and then have the MPU firmware record that measurement. After this, the battery measurement logic may use the recorded value as the battery failure limit. The same value can also be a calibration offset for any battery voltage display.

See Section 5.4.4 Battery Monitor for details regarding the ADC LSB size and the conversion accuracy.

1.5.14 EEPROM Interface

The 71M6531D/F and 71M6532D/F provide hardware support for either a two-pin or a three-wire (μ-wire) type of EEPROM interface. The interfaces use the *EECTRL* and *EEDATA* registers for communication.

Two-Pin EEPROM Interface

The dedicated 2-pin serial interface communicates with external EEPROM devices. The interface is multiplexed onto the DIO4 (SCK) and DIO5 (SDA) pins and is selected by setting $DIO_EEX[1:0] = 01$. The MPU communicates with the interface through the SFR registers *EEDATA* and *EECTRL*. If the MPU wishes to write a byte of data to the EEPROM, it places the data in *EEDATA* and then writes the Transmit code to *EECTRL*. This initiates the transmit operation which is finished when the *BUSY* bit falls. *INT5* is also asserted when *BUSY* falls. The MPU can then check the *RX_ACK* bit to see if the EEPROM acknowledged the transmission.

A byte is read by writing the Receive command to *EECTRL* and waiting for the *BUSY* bit to fall. Upon completion, the received data is in *EEDATA*. The serial transmit and receive clock is 78 kHz during each transmission and then holds in a high state until the next transmission. The *EECTRL* bits when the two-pin interface is selected are shown in [Table 47](#).

Table 47: *EECTRL* Bits for 2-pin Interface

Status Bit	Name	Read/Write	Reset State	Polarity	Description																
7	<i>ERROR</i>	R	0	Positive	1 when an illegal command is received.																
6	<i>BUSY</i>	R	0	Positive	1 when serial data bus is busy.																
5	<i>RX_ACK</i>	R	1	Negative	0 indicates that the EEPROM sent an ACK bit.																
4	<i>TX_ACK</i>	R	1	Negative	0 indicates when an ACK bit has been sent to the EEPROM.																
3:0	<i>CMD[3:0]</i>	W	0000	Positive	<table border="1"> <thead> <tr> <th><i>CMD[3:0]</i></th> <th>Operation</th> </tr> </thead> <tbody> <tr> <td>0000</td> <td>No-op command. Stops the I²C clock (SCK, DIO4). If not issued, SCK keeps toggling.</td> </tr> <tr> <td>0010</td> <td>Receive a byte from the EEPROM and send ACK.</td> </tr> <tr> <td>0011</td> <td>Transmit a byte to the EEPROM.</td> </tr> <tr> <td>0101</td> <td>Issue a STOP sequence.</td> </tr> <tr> <td>0110</td> <td>Receive the last byte from the EEPROM and do not send ACK.</td> </tr> <tr> <td>1001</td> <td>Issue a START sequence.</td> </tr> <tr> <td>Others</td> <td>No operation, set the <i>ERROR</i> bit.</td> </tr> </tbody> </table>	<i>CMD[3:0]</i>	Operation	0000	No-op command. Stops the I ² C clock (SCK, DIO4). If not issued, SCK keeps toggling.	0010	Receive a byte from the EEPROM and send ACK.	0011	Transmit a byte to the EEPROM.	0101	Issue a STOP sequence.	0110	Receive the last byte from the EEPROM and do not send ACK.	1001	Issue a START sequence.	Others	No operation, set the <i>ERROR</i> bit.
<i>CMD[3:0]</i>	Operation																				
0000	No-op command. Stops the I ² C clock (SCK, DIO4). If not issued, SCK keeps toggling.																				
0010	Receive a byte from the EEPROM and send ACK.																				
0011	Transmit a byte to the EEPROM.																				
0101	Issue a STOP sequence.																				
0110	Receive the last byte from the EEPROM and do not send ACK.																				
1001	Issue a START sequence.																				
Others	No operation, set the <i>ERROR</i> bit.																				

- The EEPROM interface can also be operated by controlling the DIO4 and DIO5 pins directly. In this case, a resistor has to be used in series with SDA to avoid data collisions due to limits in the speed at which the SDA pin can be switched from output to input. Controlling DIO4 and DIO5 directly is discouraged, because it may tie up the MPU to the point where it may become too busy to process interrupts.

Three-Wire (μ -Wire) EEPROM Interface

A 500 kHz three-wire interface, using SDATA, SCK and a DIO pin for CS is available. The interface is selected by setting $DIO_EEX[1:0] = 2$ (b10). The *EECTRL* bits when the three-wire interface is selected are shown in [Table 48](#). When *EECTRL* is written, up to 8 bits from *EEDATA* are either written to the EEPROM or read from the EEPROM, depending on the values of the *EECTRL* bits.



The μ -Wire EEPROM interface is only functional when $MPU_DIV[2:0] = 000$.

Table 48: *EECTRL* Bits for the 3-Wire Interface

Control Bit	Name	Read/Write	Description
7	<i>WFR</i>	W	Wait for Ready. If this bit is set, the trailing edge of <i>BUSY</i> will be delayed until a rising edge is seen on the data line. This bit can be used during the last byte of a Write command to cause the <i>INT5</i> interrupt to occur when the EEPROM has finished its internal write sequence. This bit is ignored if <i>HiZ</i> = 0.
6	<i>BUSY</i>	R	Asserted while the serial data bus is busy. When the <i>BUSY</i> bit falls, an <i>INT5</i> interrupt occurs.
5	<i>HiZ</i>	W	Indicates that the <i>SD</i> signal is to be floated to high impedance immediately after the last <i>SCK</i> rising edge.
4	<i>RD</i>	W	Indicates that <i>EEDATA</i> is to be filled with data from EEPROM.
3:0	<i>CNT[3:0]</i>	W	Specifies the number of clocks to be issued. Allowed values are 0 through 8. If <i>RD</i> =1, <i>CNT</i> bits of data will be read MSB first and right justified into the low order bits of <i>EEDATA</i> . If <i>RD</i> =0, <i>CNT</i> bits will be sent MSB first to the EEPROM, shifted out of the MSB of <i>EEDATA</i> . If <i>CNT[3:0]</i> is zero, <i>SDATA</i> will simply obey the <i>HiZ</i> bit.

The timing diagrams in [Figure 11](#) through [Figure 15](#) describe the 3-wire EEPROM interface behavior. All commands begin when the *EECTRL* register is written. Transactions start by first raising the *DIO* pin that is connected to *CS*. Multiple 8-bit or less commands such as those shown in [Figure 11](#) through [Figure 15](#) are then sent via *EECTRL* and *EEDATA*.

When the transaction is finished, *CS* must be lowered. At the end of a Read transaction, the EEPROM will be driving *SDATA*, but will transition to *HiZ* (high impedance) when *CS* falls. The firmware should then immediately issue a write command with *CNT*=0 and *HiZ*=0 to take control of *SDATA* and force it to a low-Z state.

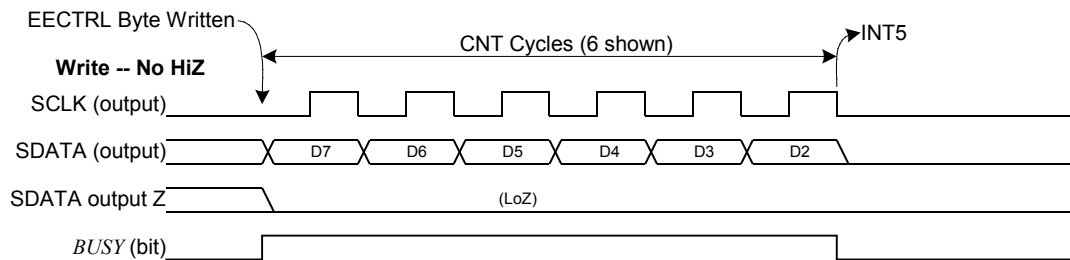
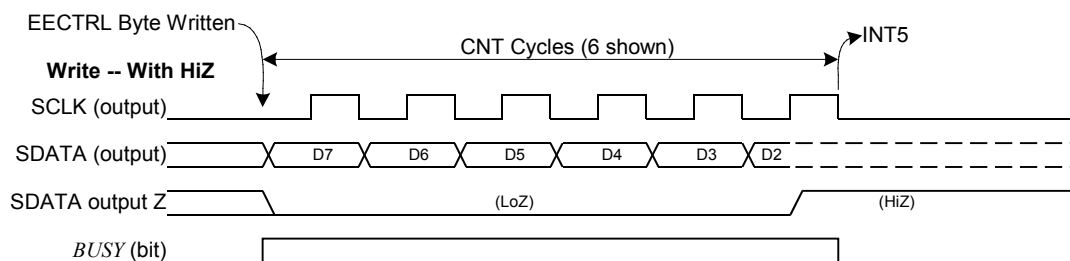
**Figure 11: 3-Wire Interface. Write Command, *HiZ*=0****Figure 12: 3-Wire Interface. Write Command, *HiZ*=1**

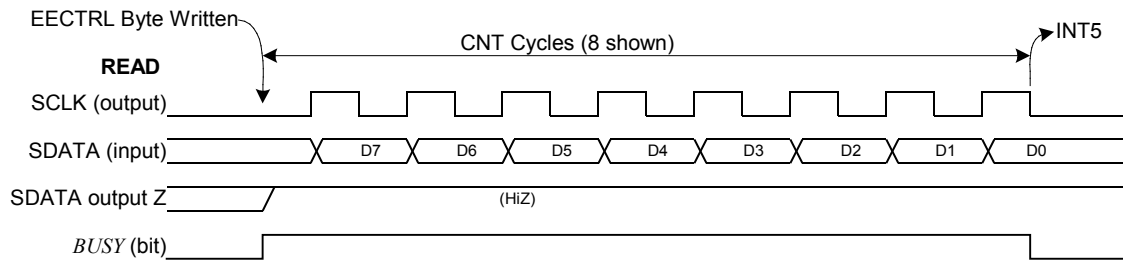

Figure 13: 3-Wire Interface. Read Command.

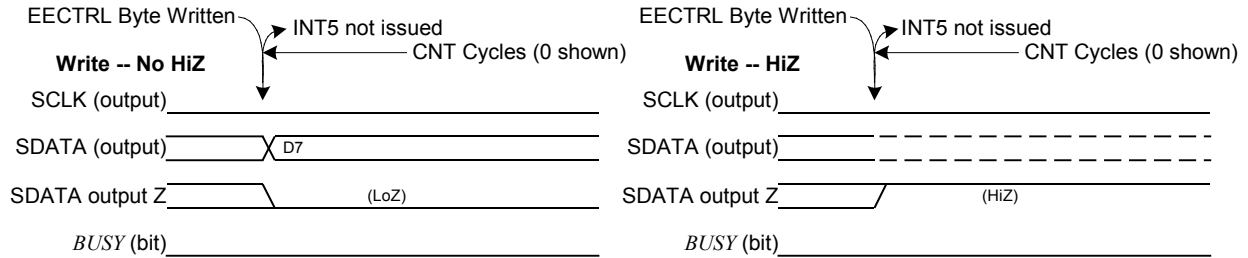

Figure 14: 3-Wire Interface. Write Command when CNT=0

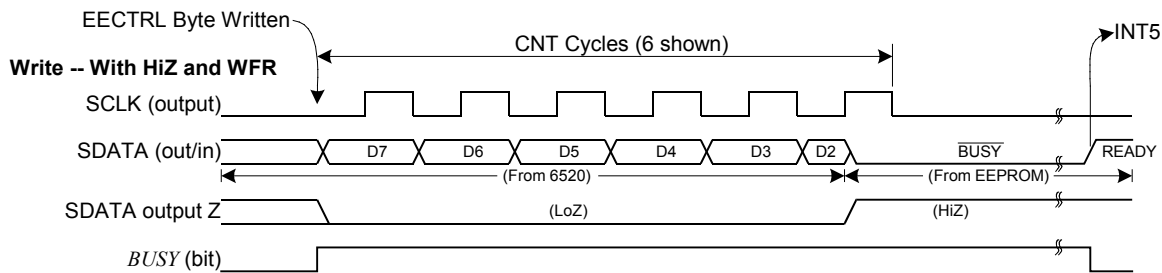

Figure 15: 3-Wire Interface. Write Command when HiZ=1 and WFR=1

1.5.15 SPI Slave Port

The slave SPI port communicates directly with the MPU data bus and is able to read and write Data RAM locations. It is also able to send commands to the MPU. The interface to the slave port consists of the PCSZ, PCLK, PSDI and PSDO pins. These pins are multiplexed with the LCD segment driver pins SEG3 to SEG6. The port pins default to LCD driver pins. The port is enabled by setting the *SPE* bit.

A typical SPI transaction is as follows. While PCSZ is high, the port is held in an initialized/reset state. During this state, PSDO is held in HiZ state and all transitions on PCLK and PSDI are ignored. When PCSZ falls, the port will begin the transaction on the first rising edge of PCLK. A transaction consists of an 8-bit command, a 16-bit address and then one or more bytes of data. The transaction ends when PCSZ is raised. Some transactions may consist of a command only.

The last SPI command and address (if part of the command) are available to the MPU in registers *SP_CMD* and *SP_ADDR*.

The SPI port supports data transfers at 1 Mb/s in mission mode and 16 kb/s in BROWNOUT mode. The SPI commands are described in [Table 49](#) and in [Figure 16](#) illustrate the SPI Interface read and write timing.

Table 49: SPI Command Description

Command	Description
11xx xxxx ADDR Byte0 ... ByteN	Read data starting at ADDR. The ADDR will auto-increment until PCSZ is raised. Upon completion: <i>SP_CMD</i> =11xx xxxx, <i>SP_ADDR</i> =ADDR+N+1. No MPU interrupt is generated if the command is 1100 0000. Otherwise, an SPI interrupt is generated.
10xx xxxx ADDR Byte0 ... ByteN	Write data starting at ADDR. The ADDR will auto-increment until PCSZ is raised. Upon completion: <i>SP_CMD</i> =10xx xxxx, <i>SP_ADDR</i> =ADDR+N+1. No MPU interrupt is generated if the command is 1000 0000. Otherwise, an SPI interrupt is generated.

Certain I/O RAM registers can be written and read using the SPI port (see Table 50). However, the MPU takes priority over the I/O RAM bus, and SPI operation may fail without notice. To avoid this situation, the SPI host should send a command other than 11xxxxxx or 10xxxxxx (read or write) before the actual read or write command. The SPI slave interface will load the command register and generate an INT2 interrupt upon receiving the command. The MPU should service the interrupt and halt any external data memory operations to effectively grant the bus to the SPI. When the SPI host finishes, it should send another command so the MPU can release the bus. There are no issues with Data RAM access; SPI and the MPU will share the bus with no conflicts for Data RAM access.

Table 50: I/O RAM Registers Accessible via SPI

Name	Address (hex)	Bit Range	Read/Write
CE0	2000	7:3	RW
CE1	2001	7:0	RW
CE2	2002	5:3, 1:0	RW
CONFIG0	2004	7:6, 3:0	RW
CONFIG1	2005	5:2, 0	RW
VERSION	2006	7:0	R
CONFIG2	2007	7:0	RW
DIO0	2008	7:6, 4:0	RW
DIO1 to DIO6	2009 to 200E	6:4, 2:0	RW
-	200F	7:6, 3:2	RW
RTM0H	2060	1:0	RW
RTM0L	2061	7:0	RW
RTM1H	2062	1:0	RW
RTM1L	2063	7:0	RW
RTM2H	2064	1:0	RW
RTM2L	2065	7:0	RW
RTM3H	2066	1:0	RW
RTM3L	2067	7:0	RW
PLS_W	2080	7:0	RW
PLS_I	2081	7:0	RW
SLOT0 to SLOT9	2090 to 209A	7:0	RW
CE3	209D	3:0	RW
CE4	20A7	7:0	RW
CE5	20A8	7:0	RW
WAKE	20A9	7:5, 3:0	R
CONFIG3	20AC	5:4, 1:0	RW
CONFIG4	20AD	5:4, 1:0	RW
-	20AF	2:0	RW

Name	Address (hex)	Bit Range	Read/Write
SPI0	20B0	4, 0	RW
SPI1	20B1	4, 0	R
VERSION	20C8	7:0	R
CHIP_ID	20C9	7:0	R
TRIMSEL	20FD	4:0	RW
TRIMX	20FE	0	RW
TRIM	20FF	7:0	RW

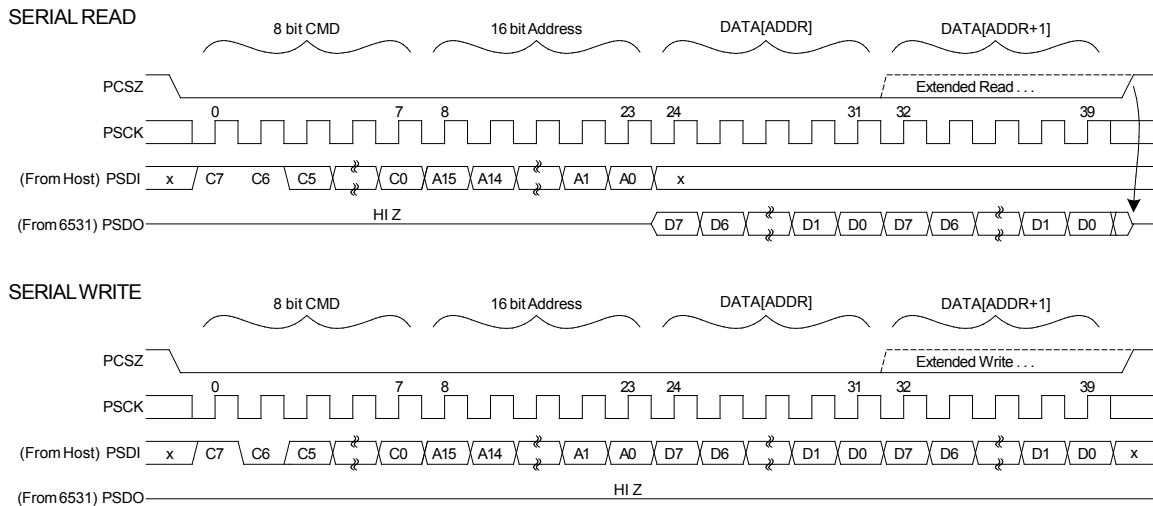
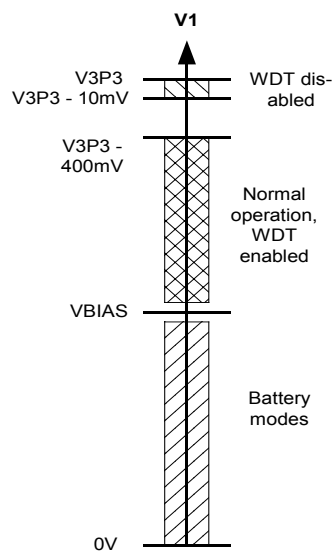

Figure 16: SPI Slave Port: Typical Read and Write operations

Possible applications for the SPI interface are:

- 1) An external host reads data from CE locations to obtain metering information. This can be used in applications where the 71M6531D/F or 71M6532D/F function as smart front-ends with preprocessing capability. Since the addresses are in 16-bit format, any type of XRAM data can be accessed: CE, MPU, I/O RAM, but not SFRs or the 80515-internal register bank.
- 2) A communication link can be established via the SPI interface: By writing into MPU memory locations, the external host can initiate and control processes in the MPU of the 71M6531D/F or 71M6532D/F. Writing to a CE or MPU location normally generates an interrupt, a function that can be used to signal to the MPU that the byte that had just been written by the external host must be read and processed. Data can also be inserted by the external host without generating an interrupt.
- 3) An external DSP can access front-end data generated by the ADC. This mode of operation uses the 71M6531D/F or 71M6532D/F as an analog front-end (AFE).

1.5.16 Hardware Watchdog Timer



An independent, robust, fixed-duration, watchdog timer (WDT) is included in the 71M6531D/F and 71M6532D/F. It uses the RTC crystal oscillator as its time base and must be refreshed by the MPU firmware at least every 1.5 seconds. When not refreshed on time, the WDT overflows and the part is reset as if the RESET pin were pulled high, except that the I/O RAM bits will be in the same state as after a wake-up from SLEEP or LCD modes (see the I/O RAM description in Section 4.2 for a list of I/O RAM bit states after RESET and wake-up). 4100 oscillator cycles (or 125 ms) after the WDT overflow, the MPU will be launched from program address 0x0000.

A status bit, *WD_OVF*, is set when the WDT overflow occurs. This bit is preserved in LCD mode (not in SLEEP mode) and can be read by the MPU when WAKE rises to determine if the part is initializing after a WDT overflow event or after a power-up. After it is read, the MPU firmware must clear *WD_OVF*. The *WD_OVF* bit is also cleared by the RESET pin.

There is no internal digital state that deactivates the WDT.

Figure 17: Functions defined by V1

The WDT can be disabled by tying the V1 pin to V3P3 (see Figure 17). Of course, this also deactivates V1 power fault detection. Since there is no method in firmware to disable the crystal oscillator or the WDT, it is guaranteed that whatever state the part might find itself in, upon watchdog overflow, the part will be reset to a known state.

Asserting ICE_E will also deactivate the WDT. This is the only method that will work in BROWNOUT mode. In normal operation, the WDT is reset by periodically writing a one to the *WDT_RST* bit. The watchdog timer is also reset when the internal signal WAKE = 0 (see Section 2.5 Wake-Up Behavior).

If enabled with the *IEN_WD_NROVF* bit in I/O RAM, an interrupt occurs roughly 1 ms before the WDT resets the chip. This can be used to determine the cause of a WDT reset since it allows the code to log its state (e.g. the current PC value, loop counters, flags, etc.) before a WDT reset occurs.

1.5.17 Test Ports (TMUXOUT pin)

One of the digital or analog signals listed in [Table 51](#) can be selected to be output on the TMUXOUT pin. The function of the multiplexer is controlled with the I/O RAM field *TMUX[4:0]* (0x20AA[4:0]), as shown in [Table 51](#).

Table 51: *TMUX[4:0]* Selections

<i>TMUX[4:0]</i>	Mode	Function
0	Analog	GNDD
1	Analog	Reserved
2	Analog	GNDD
3	Analog	Reserved
4	Analog	PLL_2P5
5	Analog	Output of the 2.5 V low-power regulator
6	Analog	Internal VBIAS voltage (nominally 1.6V)
7	Analog	Not used
8 - 0x0F	–	Reserved
0x10	Digital	RTC 1-second output
0x11	Digital	RTC 4-second output
0x12	–	Not used
0x13	Digital	V1_OK comparator output
0x14	Digital	Real-time output (RTM) from the CE
0x15	Digital	WDTR_EN (Comparator 1 Output AND V1LT3)
0x16 – 0x17	–	Not used
0x18	Digital	RXD (from Optical interface, w/ optional inversion)
0x19	Digital	MUX_SYNC
0x1A	–	Not used
0x1B	Digital	CKMPU (MPU clock)
0x1C	Digital	Pulse output
0X1D	Digital	RTCLK (output of the oscillator circuit, nominally 32,786Hz)
0X1E	Digital	CE_BUSY (busy interrupt generated by CE, 396µs)
0X1F	Digital	XFER_BUSY (transfer busy interrupt generated by the CE, nominally every 999.7ms)

The TMUXOUT pin may be used for diagnosis purposes or in production test. The RTC 1-second output may be used to calibrate the crystal oscillator. The RTC 4-second output provides even higher precision.

2 Functional Description

2.1 Theory of Operation

The energy delivered by a power source into a load can be expressed as:

$$E = \int_0^t V(t)I(t)dt$$

Assuming phase angles are constant, the following formulae apply:

- $P = \text{Real Energy [Wh]} = V * A * \cos \phi * t$
- $Q = \text{Reactive Energy [VARh]} = V * A * \sin \phi * t$
- $S = \text{Apparent Energy [VAh]} = \sqrt{P^2 + Q^2}$

For a practical meter, not only voltage and current amplitudes, but also phase angles and harmonic content may change constantly. Thus, simple RMS measurements are inherently inaccurate. A modern solid-state electricity meter IC such as the 71M6531 functions by emulating the integral operation above, i.e. it processes current and voltage samples through an ADC at a constant frequency. As long as the ADC resolution is high enough and the sample frequency is beyond the harmonic range of interest, the current and voltage samples, multiplied with the time period of sampling will yield an accurate quantity for the momentary energy. Summing up the momentary energy quantities over time will result in accumulated energy.

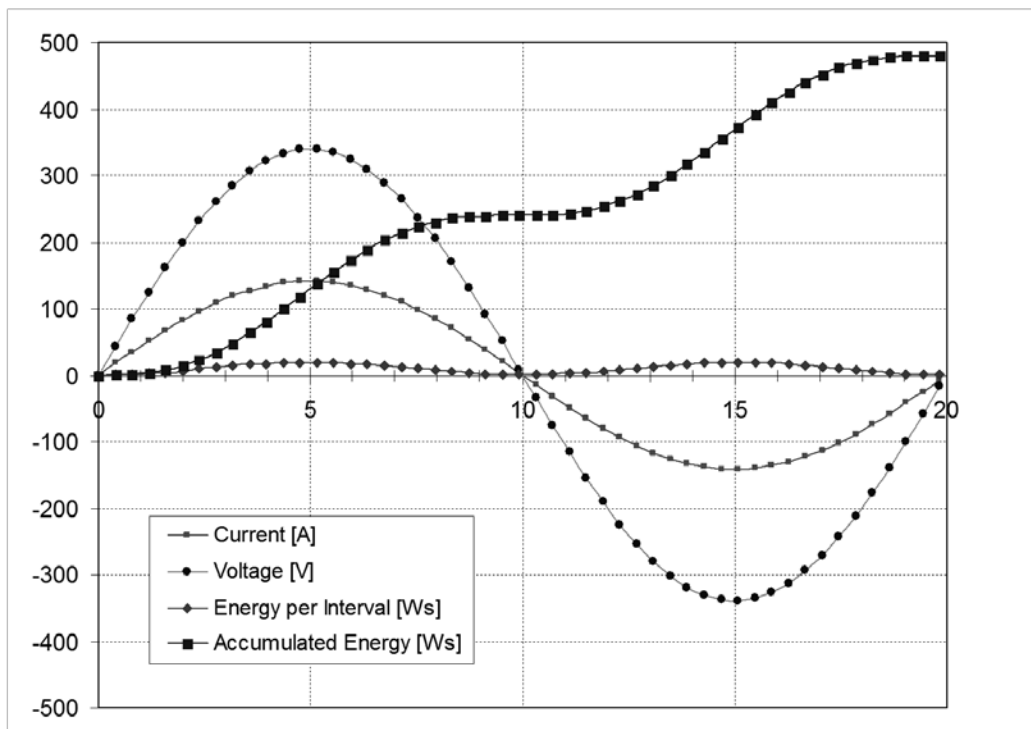

Figure 18: Voltage, Current, Momentary and Accumulated Energy

Figure 18 shows the shapes of $V(t)$, $I(t)$, the momentary power and the accumulated power, resulting from 50 samples of the voltage and current signals over a period of 20 ms. The application of 240 VAC and 100 A results in an accumulation of 480 Ws (= 0.133 Wh) over the 20 ms period, as indicated by the accumulated power curve. The described sampling method works reliably, even in the presence of dynamic phase shift and harmonic distortion.

2.2 System Timing Summary

Figure 19 summarizes the timing relationships between the input MUX states, the CE_BUSY signal and the two serial output streams. In this example, $MUX_DIV[3:0] = 4$ and $FIR_LEN[1:0] = 2$ (384 CE cycles, 3 CK32 cycles per conversion), resulting in 13 CK32 cycles per multiplexer frame. Generally, the duration of each MUX frame is:

- $1 + MUX_DIV * 1$, if $FIR_LEN[1:0] = 0$ (138 CE cycles)
- $1 + MUX_DIV * 2$, if $FIR_LEN[1:0] = 1$ (288 CE cycles)
- $1 + MUX_DIV * 3$, if $FIR_LEN[1:0] = 2$ (384 CE cycles).

An ADC conversion will always consume an integer number of CK32 clocks. Following this is a single CK32 cycle where the bandgap voltage is allowed to recover from the change in CROSS.

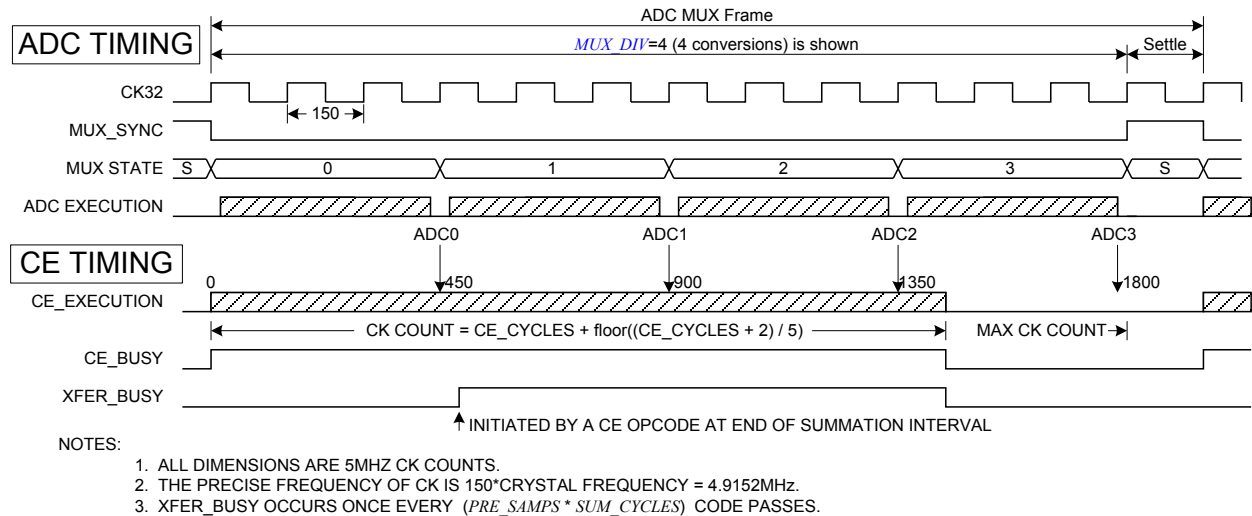

Figure 19: Timing Relationship between ADC MUX, Compute Engine

Each CE program pass begins when the ADC0 conversion (for IA) begins. Depending on the length of the CE program, it may continue running until the end of the last conversion (ADC3). CE opcodes are constructed to ensure that all CE code passes consume exactly the same number of cycles. The result of each ADC conversion is inserted into the RAM when the conversion is complete. The CE code is written to tolerate sudden changes in ADC data. The exact clock count when each ADC value is loaded into RAM is shown in Figure 19.

Figure 20 shows that the serial data stream, RTM, begins transmitting at the beginning of state S. RTM, consisting of 140 CK cycles, will always finish before the next code pass starts.

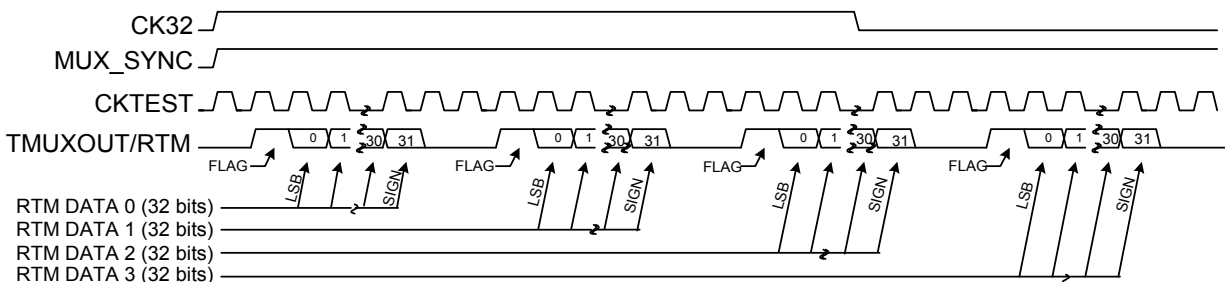

Figure 20: RTM Output Format

2.3 Battery Modes

Shortly after system power ($V3P3SYS$) is applied, the part will be in MISSION mode. MISSION mode means that the part is operating with system power and that the internal PLL is stable. This mode is the normal operation mode where the part is capable of measuring energy.

When system power is not available (i.e. when $V1 < VBIAS$), the 71M6531 will be in one of three battery modes: BROWNOUT, LCD, or SLEEP mode. Figure 21 shows a state diagram of the various operation modes, with the possible transitions between modes. For information on the timing of mode transitions refer to Figure 22 through Figure 24.

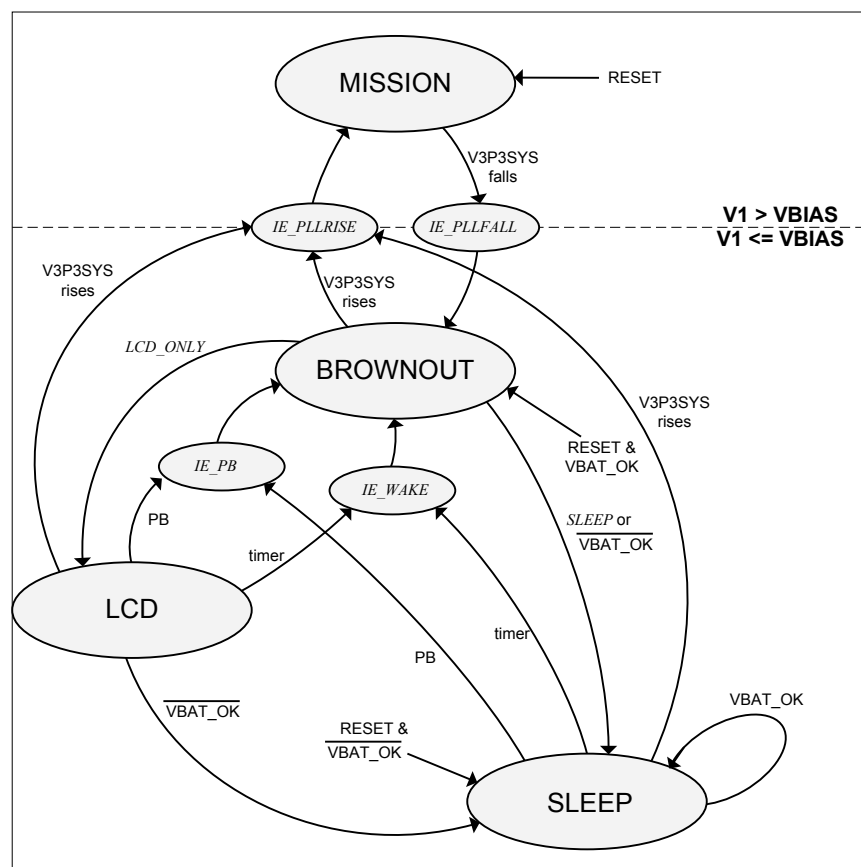

Figure 21: Operation Modes State Diagram

When $V1$ falls below $VBIAS$ or the part wakes up under battery power, the part will automatically enter BROWNOUT mode (see Section 2.5 Wake-Up Behavior). From BROWNOUT mode, the part may enter either LCD mode or SLEEP mode, as controlled by the MPU via the I/O RAM bits LCD_ONLY and $SLEEP$.

The transition from MISSION mode to BROWNOUT mode is signaled by the $IE_PLLFALL$ interrupt flag (SFR 0xE8[7]). The transition in the other direction is signaled by the $IE_PLLRISE$ interrupt flag (SFR 0xE8[6]), when the PLL becomes stable.

- ⊘ Meters that do not require functionality in the battery modes, e.g. meters that only use the SLEEP mode to maintain the RTC, still need to contain code that brings the chip from BROWNOUT mode to SLEEP mode. Otherwise, the chip remains in BROWNOUT mode once the system power is missing and consumes more current than intended.
- ⊘ Similarly, meters equipped with batteries need to contain code that transitions the chip to SLEEP mode as soon as the battery is attached in production. Otherwise, remaining in BROWNOUT mode would unnecessarily drain the battery.

To facilitate transition to SLEEP mode, which is useful when an unprogrammed IC is mounted on a PCB with a battery installed, the production test programs the following six-byte sequence into the flash location starting at address 0x00000: 0x74 - 0x40 - 0x90 - 0x20 - 0xA9 - 0xF0. This sequence decodes to the following assembler code:

```
0000: 7440      MOV A, #40      ; set bit 6 in accumulator
0002: 9020A9     MOV DPTR, #20A9 ; point to I/O RAM address 0x20A9
0005: F0        MOVX @DPTR, A   ; set bit 6 (sleep) in 0x20A9
```

Transitions from both LCD and SLEEP mode are initiated by the wake-up timer timeout conditions or pushbutton events. When the PB pin is pulled high (pushbutton is pressed), the *IE_PB* interrupt flag (SFR 0xE8[4]) is set, and when the wake-up timer times out, the *IE_WAKE* interrupt flag (SFR 0xE8[5]) is set.

In the absence of system power, if the voltage margin for the LDO regulator providing 2.5 V to the internal circuitry becomes too low to be safe, the part automatically enters SLEEP mode (BAT_OK false). The battery voltage must stay above 3 V to ensure that BAT_OK remains true. Under this condition, the 71M6531 stays in SLEEP mode, even if the voltage margin for the LDO improves (BAT_OK true). [Table 52](#) shows the circuit functions available in each operating mode.

Table 52: Available Circuit Functions

Circuit Function	System Power	Battery Power (Nonvolatile Supply)		
	MISSION	BROWNOUT	LCD	SLEEP
CE	Yes	–	–	–
CE Data RAM	Yes	Yes	–	–
FIR	Yes	–	–	–
Analog circuits	Yes	–	–	–
MPU clock rate	From PLL, as defined by <i>MPU_DIV[2:0]</i>	28.672 kHz (7/8 of 32768 Hz)	–	–
<i>MPU_DIV[2:0]</i>	Yes	–	–	–
ICE	Yes	Yes	–	–
DIO Pins	Yes	Yes	–	–
Watchdog Timer	Yes	Yes	–	–
LCD	Yes	Yes	Yes	–
EEPROM Interface (2-wire)	Yes	Yes (8 kb/s)	–	–
EEPROM Interface (3-wire)	Yes	Yes (16 kb/s)	–	–
UART	Yes	300 bd	–	–
Optical TX modulation	Yes	–	–	–
Flash Read	Yes	Yes	–	–
Flash Page Erase	Yes	Yes	–	–
Flash Write	Yes	–	–	–
RAM Read and Write	Yes	Yes	–	–
Wakeup Timer	Yes	Yes	Yes	Yes
OSC and RTC	Yes	Yes	Yes	Yes
XRAM data preservation	Yes	Yes	–	–
V3P3D voltage output pin	Yes	Yes	–	–
<i>GPO – GP7</i> registers	Yes	Yes	Yes	Yes

– indicates not active

2.3.1 BROWNOUT Mode

In BROWNOUT mode, most non-metering digital functions are active (as shown in [Table 52](#)), including ICE, UART, EEPROM, LCD and RTC. In BROWNOUT mode, a low bias current regulator will provide 2.5 Volts to V2P5 and V2P5NV. The regulator has an output called BAT_OK to indicate that it has sufficient overhead. When BAT_OK = 0, the part will enter SLEEP mode. From BROWNOUT mode, the processor

can voluntarily enter LCD or SLEEP modes. When system power is restored, the part will automatically transition from any of the battery modes to MISSION mode, once the PLL has settled.

The MPU will run at 7/8 of the crystal clock rate. This permits the UARTs to be operated at 300 bd. In this mode, the MPU clock has substantial short-term jitter.

The value of *MPU_DIV[2:0]* will be remembered (not changed) as the part enters and exits BROWNOUT. *MPU_DIV[2:0]* will be ignored during BROWNOUT.

While *PLL_OK* = 0, the I/O RAM bits *ADC_E* and *CE_E* are held in the zero state disabling both the ADC and the CE. When *PLL_OK* falls, the CE program counter is cleared immediately and all FIR processing halts.

2.3.2 LCD Mode

In LCD mode, the data contained in the *LCD_SEGn[3:0]* fields is displayed. Up to four LCD segments, each connected to pins SEG18 and SEG19, can be made to blink without the involvement of the MPU, which is disabled in LCD mode. To minimize power, only segments that might be used should be enabled.

LCD mode can be exited only by system power up, a timeout of the wake-up timer, or a push button. When the IC exits LCD mode, the MPU can discover the event that caused the exit by reading the interrupt flags and interpret them as follows:

- *IE_WAKE* = 1 indicates that the wake timer has expired.
- *IE_PB* = 1 indicates that the pushbutton input (PB) was activated.
- *COMPSTAT* = 0 indicates that a reset occurred but that main power is not yet available.
- If none of the above conditions applies, system power (V3P3SYS) must have been restored

After the transition from LCD mode to MISSION or BROWNOUT mode, the *PC* will be at 0x0000, the XRAM is in an undefined state and the I/O RAM is only partially preserved (see the description of I/O RAM states in Section 4.2). The *GP0[7:0]* through *GP7[7:0]* registers are preserved unless RESET goes high.

2.3.3 SLEEP Mode

In SLEEP mode, the battery current is minimized and only the Oscillator and RTC functions are active. This mode can be exited only by system power-up, a timeout of the wake-up timer, or a push button event.

When the IC exits SLEEP mode, the MPU can discover the event that caused the exit by reading the interrupt flags and interpret them as follows:

- *IE_WAKE* = 1 indicates that the wake timer has expired.
- *IE_PB* = 1 indicates that the pushbutton input (PB) was activated.
- *COMPSTAT* = 0 indicates that a reset occurred but that main power is not yet available.
- If none of the above conditions applies, system power (V3P3SYS) must have been restored

After the transition from SLEEP mode to MISSION or BROWNOUT mode the *PC* will be at 0x0000, the XRAM is in an undefined state and the I/O RAM is only partially preserved (see the description of I/O RAM states in Section 4.2). The *GP0[7:0]* through *GP7[7:0]* registers are preserved unless RESET goes high.

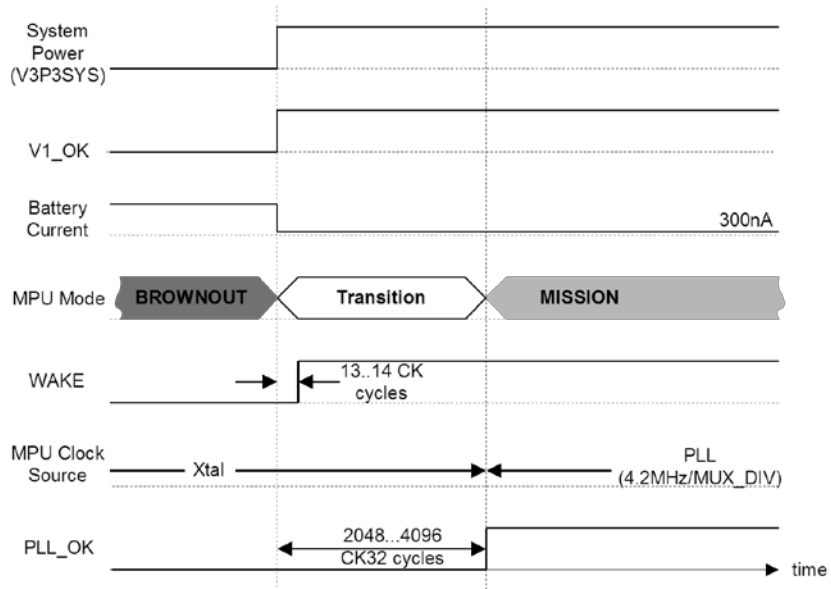

Figure 22: Transition from BROWNOUT to MISSION Mode when System Power Returns

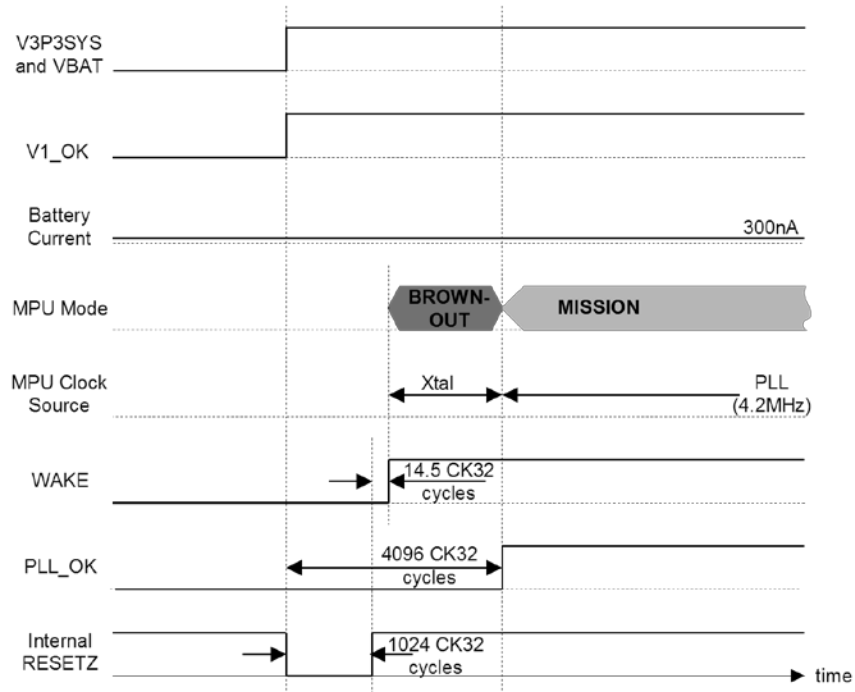

Figure 23: Power-Up Timing with V3P3SYS and VBAT tied together

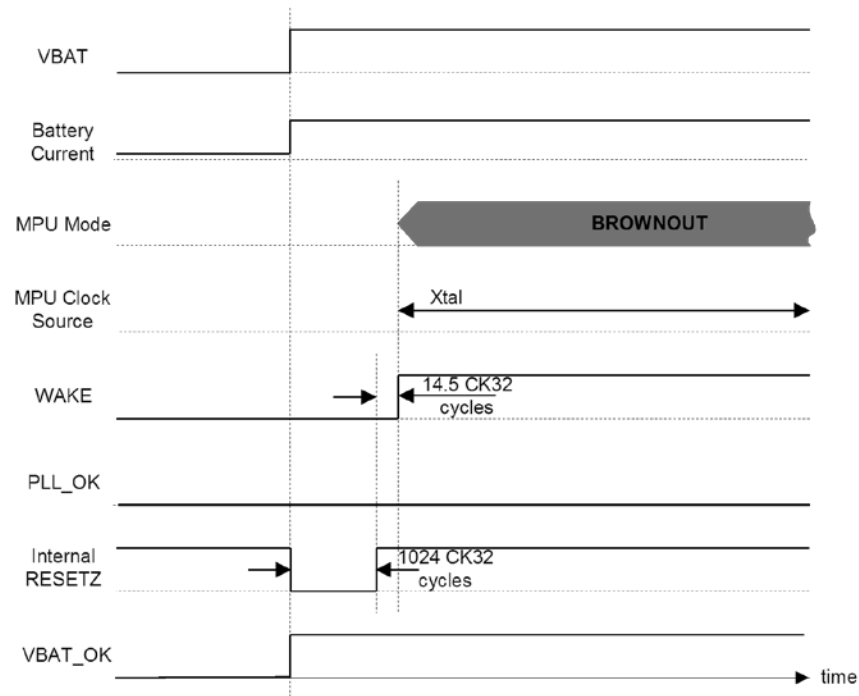

Figure 24: Power-Up Timing with VBAT only

2.4 Fault and Reset Behavior

2.4.1 Reset Mode

When the RESET pin is pulled high, all digital activity stops. The oscillator and RTC module continue to run. Additionally, all I/O RAM bits are set to their default states. As long as V1, the input voltage at the power fault block, is greater than VBIAS, the internal 2.5 V regulator will continue to provide power to the digital section.

Once initiated, the reset mode will persist until the reset timer times out, signified by WAKE rising. This will occur in 4100 cycles of the real time clock after RESET goes low, at which time the MPU will begin executing its pre-boot and boot sequences from address 00. See the [Program Security](#) description in the [Flash Memory](#) section for additional descriptions of pre-boot and boot.

If system power is not present, the reset timer duration will be 2 cycles of the crystal clock at which time the MPU will begin executing in BROWNOUT mode, starting at address 00.

2.4.2 Power Fault Circuit

The 71M6531D/F and 71M6532D/F include a comparator to monitor system power fault conditions. When the output of the comparator falls ($V1 < VBIAS$), the I/O RAM bits *PLL_OK* bit is zeroed and the part switches to BROWNOUT mode if a battery is present (and the MPU keeps executing code). If a battery is not present, as indicated by *BAT_OK*=0, WAKE will fall and the part will enter SLEEP mode. Once system power returns, the MPU remains in reset and does not transition to MISSION mode until 2048 to 4096 CK32 clock cycles later, when *PLL_OK* rises. There are several conditions the device could be in as system power returns. If the part is in BROWNOUT mode, it will automatically switch to MISSION mode when *PLL_OK* rises. It will receive an interrupt indicating this. No configuration bits will be reset or reconfigured during this transition.

If the part is in LCD or SLEEP mode when system power returns, it will also switch to MISSION mode when *PLL_OK* rises. In this case, all configuration bits will be in the reset state due to WAKE having been zero. The RTC clock will not be disturbed, but the MPU RAM must be re-initialized. The hardware watchdog timer will become active when the part enters MISSION mode.

If there is no battery when system power returns, the part will switch to MISSION mode when *PLL_OK* rises. All configuration bits will be in reset state and RTC and MPU RAM data will be unknown and must be initialized by the MPU.

2.5 Wake-Up Behavior

As described above, the part will always wake up in MISSION mode when system power is restored. Additionally, the part will wake up in BROWNOUT mode when PB rises (push button is pressed) or when a timeout of the wake-up timer occurs.

2.5.1 Wake on PB

If the part is in SLEEP or LCD mode, it can be awakened by a rising edge on the PB pin. This pin is normally pulled to GND and can be pulled high by a push button depression. Before the PB signal rises, the MPU is in reset due to WAKE being low. When PB rises, WAKE rises and within three crystal cycles, the MPU begins to execute. The MPU can determine whether the PB signal woke it up by checking the *IE_PB* flag. Figure 25 shows the Wake Up timing.

For debouncing, the PB pin is monitored by a state machine operating from a 32 Hz clock. This circuit will reject between 31 ms and 62 ms of noise. Detection hardware will ignore all transitions after the initial rising edge. This will continue until the MPU clears the *IE_PB* bit.

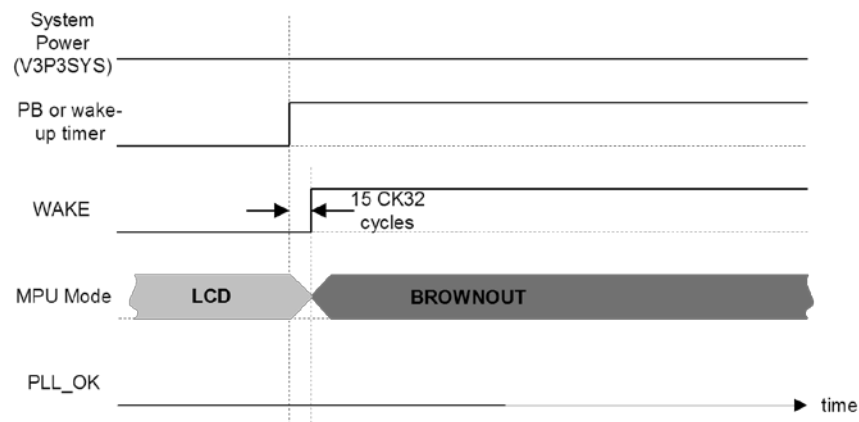

Figure 25: Wake Up Timing

2.5.2 Wake on Timer

If the part is in SLEEP or LCD mode, it can be awakened by the wake-up timer. Until this timer times out, the MPU is in reset due to WAKE being low. When the wake-up timer times out, the WAKE signal rises and within three crystal cycles, the MPU begins to execute. The MPU can determine whether the timer woke it by checking the *AUTOWAKE* interrupt flag (*IE_WAKE*).

The wake-up timer begins timing when the part enters LCD or SLEEP mode. Its duration is controlled by *WAKE_PRD[2:0]* and *WAKE_RES*. *WAKE_RES* selects a timer LSB of either 1 minute (*WAKE_RES* = 1) or 2.5 seconds (*WAKE_RES* = 0). *WAKE_PRD[2:0]* selects a duration of from 1 to 7 LSBs.

The timer is armed by *WAKE_ARM* = 1. It must be armed at least three RTC cycles before *SLEEP* or *LCD_ONLY* is initiated. Setting *WAKE_ARM* presets the timer with the values in *WAKE_RES* and *WAKE_PRD* and readies the timer to start when the processor writes to *SLEEP* or *LCD_ONLY*. The timer is reset and disarmed whenever the processor is awake. Thus, if it is desired to wake the MPU periodically (every 5 seconds, for example) the timer must be rearmed every time the MPU is awakened.

2.6 Data Flow

The data flow between the Compute Engine (CE) and the MPU is shown in Figure 26. In a typical application, the 32-bit CE sequentially processes the samples from the voltage inputs on pins IA, VA, IB and VB, performing calculations to measure active power (Wh), reactive power (VARh), A^2h and V^2h for four-quadrant metering. These measurements are then accessed by the MPU, processed further and output using the peripheral devices available to the MPU.

Figure 26 illustrates the CE/MPU data flow.

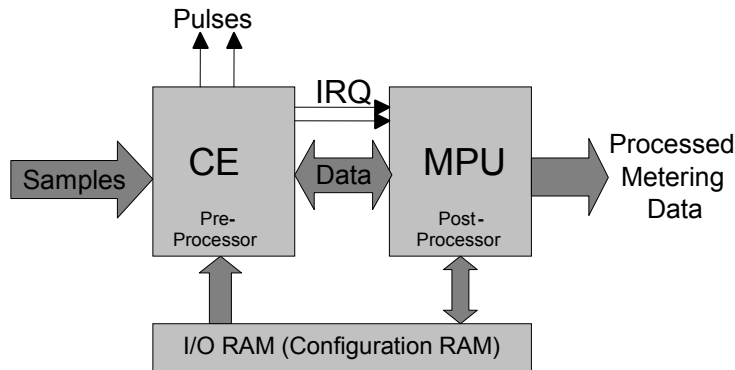

Figure 26: MPU/CE Data Flow

2.7 CE/MPU Communication

Figure 27 shows the functional relationships between the CE and the MPU. The CE is controlled by the MPU via shared registers in the I/O RAM and in RAM.

The CE outputs two interrupt signals to the MPU: CE_BUSY and XFER_BUSY, which are connected to the MPU interrupt service inputs as external interrupts. CE_BUSY indicates that the CE is actively processing data. This signal will occur once every multiplexer cycle. XFER_BUSY indicates that the CE is updating data to the output region of the RAM. This will occur whenever the CE has finished generating a sum by completing an accumulation interval determined by $SUM_CYCLES[5:0] * PRE_SAMPS[1:0]$ samples. Interrupts to the MPU occur on the falling edges of the XFER_BUSY and CE_BUSY signals.

Refer to Section 4.3 CE Interface Description for additional information on setting up the device using the MPU firmware.

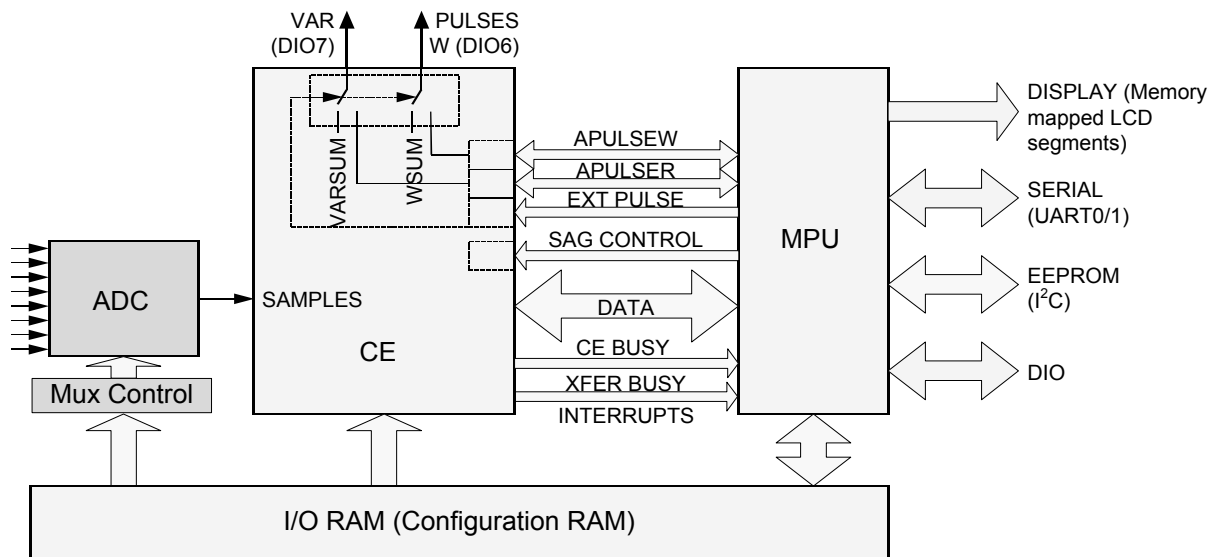

Figure 27: MPU/CE Communication

3 Application Information

3.1 Connection of Sensors

Figure 28 through Figure 30 show how resistive dividers, current transformers, Rogowski coils and resistive shunts are connected to the voltage and current inputs of the 71M6531.

- ☑ The analog input pins of the 71M65XX are designed for sensors with low source impedance. RC filters with resistance values higher than those implemented in the Demo Boards should be avoided. See Application Note AN5292 for details on filter implementation.

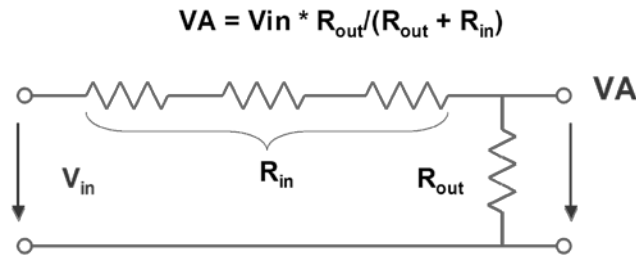

Figure 28: Resistive Voltage Divider

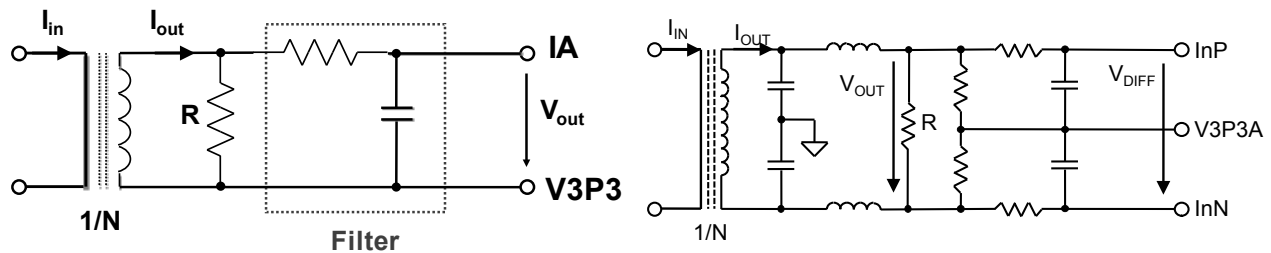

Figure 29: CT with Single Ended (Left) and Differential Input (Right) Connection

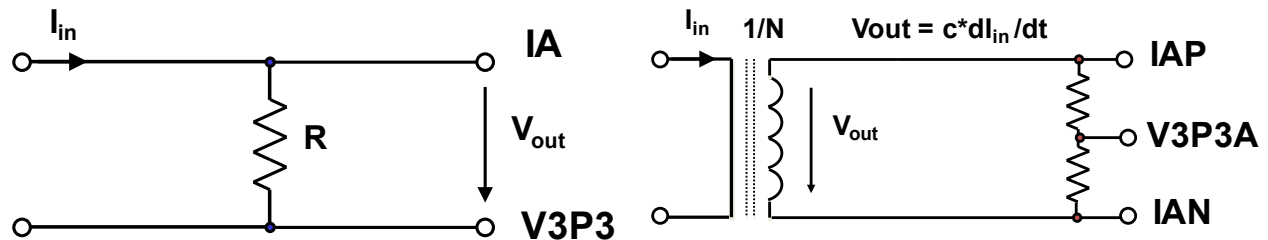

Figure 30: Resistive Shunt (Left) and Rogowski Sensor (Right) Connection

Note: Ferrites or other inductive components must not be connected directly to the sensor input pins (InP, InN, Vn).

3.2 Connecting 5-V Devices

All digital input pins of the 71M6531D/F and 71M6532D/F are compatible with external 5-V devices. I/O pins configured as inputs do not require current-limiting resistors when they are connected to external 5 V devices.

3.3 Temperature Measurement

Measurement of absolute temperature uses the on-chip temperature sensor and applying the following formula:

$$T = \frac{(N(T) - N_n)}{S_n} + T_n$$

In the above formula, T is the temperature in °C, $N(T)$ is the ADC count at temperature T , N_n is the ADC count at 25°C, S_n is the sensitivity in LSB/°C as stated in the Electrical Specifications and T_n is +25 °C.

It is recommended that temperature measurements be based on $TEMP_RAW_X$ which is the sum of two consecutive temperature readings, thus being higher by a factor of two than the raw sensor readings.

3.4 Temperature Compensation

3.4.1 Temperature Coefficients:

The internal voltage reference VREF is calibrated during device manufacture.

The temperature coefficient TC2 is given as a constant that represents typical component behavior (in $\mu\text{V}/^\circ\text{C}^2$). TC1 ($\mu\text{V}/^\circ\text{C}$) can be calculated for the individual chip from the contents of the $TRIMT[7:0]$ I/O RAM register. TC1 and TC2 allow compensation for variations of the reference voltage to within ± 40 PPM/°C.

 Since TC1 and TC2 are given in $\mu\text{V}/^\circ\text{C}$ and $\mu\text{V}/^\circ\text{C}^2$, respectively, the value of the VREF voltage (1.195V) has to be taken into account when transitioning to PPM/°C and PPM/°C². This means that $\text{PPMC} = 26.84 * \text{TC1} / 1.195$ and $\text{PPMC2} = 1374 * \text{TC2} / 1.195$.

Close examination of the electrical specification (see Table 53) reveals that the achievable deviation is not strictly ± 40 PPM/°C over the whole temperature range: Only for temperatures for which $T - 22 > 40$ (i.e. $T > 62^\circ\text{C}$) or for which $T - 22 < -40$ (i.e. $T < -18^\circ\text{C}$), the data sheet states ± 40 PPM/°C. For temperatures between -18°C and $+62^\circ\text{C}$, the error should be considered constant at $\pm 1,600$ PPM, or $\pm 0.16\%$.

Parameter	Condition	Min		Typ
VREF(T) deviation from VNOM(T) $\frac{VREF(T) - VNOM(T)}{VNOM(T)} \frac{10^6}{\max(T - 22 , 40)}$		-40	+40	PPM/°C

Table 53: VREF Definition for 6531

Figure 31 shows this concept graphically. The “box” from -18°C to $+62^\circ\text{C}$ reflects the fact that it is impractical to measure the temperature coefficient of high-quality references at small temperature excursions. For example, at $+25^\circ\text{C}$, the expected error would be $\pm 3^\circ\text{C} * 40$ PPM/°C, or just 0.012%.

The maximum deviation of ± 2520 PPM (or 0.252%) is reached at the temperature extremes. If the reference voltage is used to measure both voltage and current, the identical errors of $\pm 0.252\%$ add up to a maximum Wh registration error of $\pm 0.504\%$.

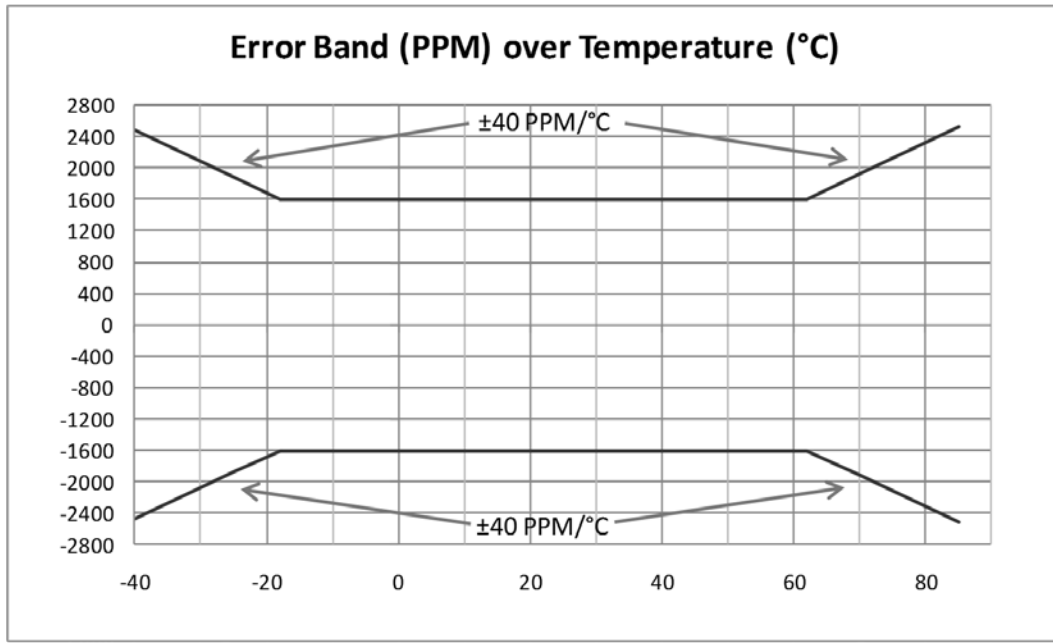

Figure 31: Error Band for VREF over Temperature

3.4.2 Temperature Compensation for VREF

The bandgap temperature is used to digitally compensate the power outputs for the temperature dependence of VREF, using the CE register *GAIN_ADJ*. Since the band gap amplifier is chopper-stabilized, the most significant long-term drift mechanism in the voltage reference is removed.

The following formula is used to determine the *GAIN_ADJ* value of the CE. In this formula, *TEMP_X* is the deviation from nominal or calibration temperature expressed in multiples of 0.1 °C:

$$GAIN_ADJ = 16385 + \frac{TEMP_X \cdot PPMC}{2^{14}} + \frac{TEMP_X^2 \cdot PPMC2}{2^{23}}$$

3.4.3 System Temperature Compensation

In a production electricity meter, the 71M6531 or 71M6532D/F is not the only component contributing to temperature dependency. A whole range of components (e.g. current transformers, resistor dividers, power sources, filter capacitors) will contribute temperature effects.

Since the output of the on-chip temperature sensor is accessible to the MPU, temperature compensation mechanisms with great flexibility are possible. MPU access to *GAIN_ADJ* permits a system-wide temperature correction over the entire meter rather than local to the chip.

3.4.4 Temperature Compensation for the RTC

In order to obtain accurate readings from the RTC, the following procedure is recommended:

1. At the time of meter calibration, the crystal oscillator may be calibrated using the *RTCA_ADJ* register in I/O RAM to be as close to 32768 Hz as possible. The recommended procedure is to connect a high-precision frequency counter to the TMUXOUT pin and select 0x11 for *TMUX[4:0]*. This will generate a 4-second pulse at TMUXOUT that can be used to trim *RTCA_ADJ* to the best value. A wider trim range is achieved with the I/O RAM registers *PREG[16:0]* and *QREG[1:0]*.
2. When the meter is in service, the MPU takes frequent temperature readings. If the temperature characteristics of the crystal are known, the temperature readings can be used to modify the settings for the I/O RAM registers *PREG[16:0]* and *QREG[1:0]* in order to keep the crystal frequency close to 32768 Hz.
3. After periods of operation under battery power, the temperature for the time the meter was not powered can be estimated by averaging the temperatures before and after battery operation. Based on this, the overall correction for the RTC time can be calculated and applied to the RTC after main power returns.

to the meter.

3.5 Connecting LCDs

The 71M6531D/F and 71M6532D/F have an on-chip LCD controller capable of controlling static or multiplexed LCDs. [Figure 32](#) shows the basic connection for an LCD.

The following dedicated and multi-use pins can be assigned as LCD segment pins for the 71M6531D/F:

- 12 dedicated LCD segment pins: SEG0 to SEG2, SEG7, SEG8, SEG12 to SEG18.
- 7 dual-function pins: SEG3/PCLK, SEG4/PSDO, SEG5/PCSZ, SEG6/PSDI, E_RXTX/SEG9, E_TCLK/SEG10, and E_RST/SEG11.
- 14 combined DIO and segment pins: SEG24/DIO4 to SEG35/DIO15, SEG37/DIO17, SEG48/DIO28, SEG49/DIO29 and SEG63/DIO43 to SEG66/DIO46.

The following dedicated and multi-use pins can be assigned as LCD segments for the 71M6532D/F:

- 15 dedicated LCD segment pins: SEG0 to SEG2, SEG8, SEG12 - SEG18, SEG20 - SEG23.
- 9 dual-function pins: MUX_SYNC/SEG7, E_RXTX/SEG9, E_TCLK/SEG10, E_RST/SEG11, SEG3/PCLK, SEG4/PSDO, SEG5/PCSZ, SEG6/PSDI.
- 43 combined DIO and segment pins, as described in section 1.5.8.

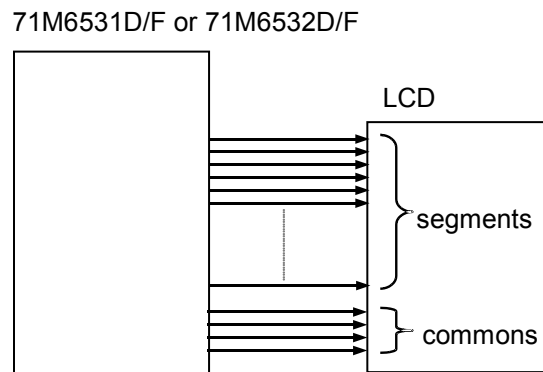

Figure 32: Connecting LCDs

3.6 Connecting I²C EEPROMs

I²C EEPROMs or other I²C compatible devices should be connected to the DIO pins DIO4 and DIO5, as shown in [Figure 33](#).

Pull-up resistors of roughly 10 k Ω to V3P3D (to ensure operation in BROWNOUT mode) should be used for both SCL and SDA signals. The *DIO_EEX[1:0]* register in I/O RAM must be set to 01 in order to convert the DIO pins DIO4 and DIO5 to I²C pins SCL and SDA.

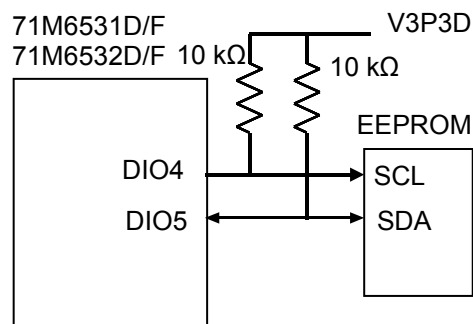

Figure 33: I²C EEPROM Connection

3.7 Connecting Three-Wire EEPROMs

μ Wire EEPROMs and other compatible devices should be connected to the DIO pins DIO4 and DIO5, as shown in Figure 34 and described below:

- DIO5 connects to both the DI and DO pins of the three-wire device.
- The CS pin must be connected to a vacant DIO pin of the 71M6531.
- In order to prevent bus contention, a 10 k Ω resistor is used to separate the DI and DO signals.
- The CS and CLK pins should be pulled down with resistors to prevent operation of the three-wire device on power-up, before the 71M6531 can establish a stable signal for CS and CLK.
- The *DIO_EEX[1:0]* register in I/O RAM must be set to 2 (b10) in order to convert the DIO pins DIO4 and DIO5 to μ Wire pins.



The μ -Wire EEPROM interface is only functional when *MPU_DIV[2:0]* = 000.

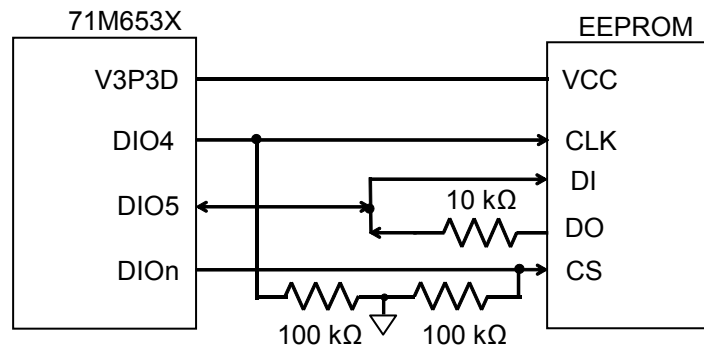

Figure 34: Three-Wire EEPROM Connection

3.8 UART0 (TX/RX)

The UART0 RX pin should be pulled down by a 10 k Ω resistor and additionally protected by a 100 pF ceramic capacitor, as shown in Figure 35.

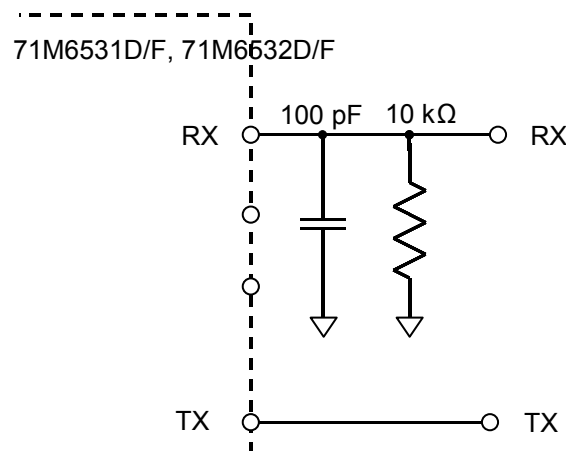

Figure 35: Connections for UART0

3.9 Optical Interface (UART1)

The OPT_TX and OPT_RX pins can be used for a regular serial interface (by connecting a RS-232 transceiver for example), or they can be used to directly operate optical components (for example, an infrared diode and phototransistor implementing a FLAG interface). Figure 36 shows the basic connections for UART1. The OPT_TX pin becomes active when the I/O RAM register *OPT_TXE* is set to 00.

The polarity of the OPT_TX and OPT_RX pins can be inverted with the configuration bits, *OPT_TXINV* and *OPT_RXINV*, respectively.

The OPT_TX output may be modulated at 38 kHz when system power is present. Modulation is not available in BROWNOUT mode. The *OPT_TXMOD* bit enables modulation. The duty cycle is controlled by *OPT_FDC[1:0]*, which can select 50%, 25%, 12.5% and 6.25% duty cycle. A 6.25% duty cycle means OPT_TX is low for 6.25% of the period. The OPT_RX pin uses digital signal thresholds. It may need an analog filter when receiving modulated optical signals.



With modulation, an optical emitter can be operated at higher current than nominal, enabling it to increase the distance along the optical path.

If operation in BROWNOUT mode is desired, the external components should be connected to V3P3D.

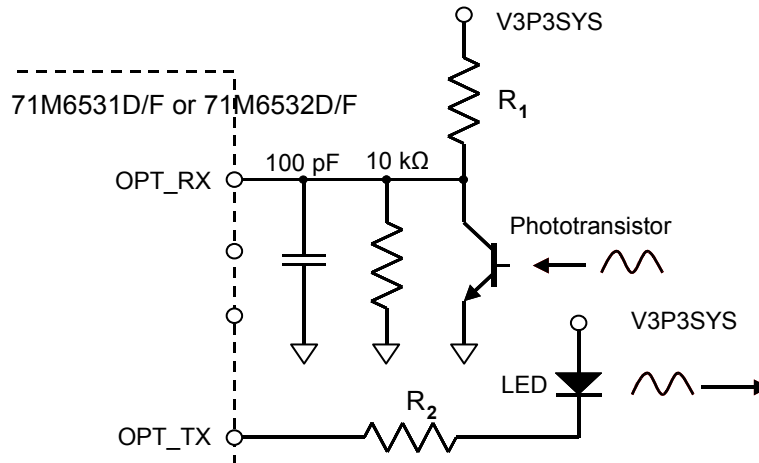

Figure 36: Connection for Optical Components

3.10 Connecting the V1 Pin

A voltage divider should be used to establish that V1 is in a safe range when the meter is in MISSION mode (see [Figure 37](#)). V1 must be lower than 2.9 V in all cases in order to keep the hardware watchdog timer enabled. The resistor divider ratio must be chosen so that V1 crosses the VBIAS threshold when V3P3 is near the minimum supply voltage (3.0 VDC). A series resistor (R3) provides additional hysteresis, and a capacitor to ground (C1) is added for enhanced EMC immunity.

The amount of hysteresis depends on the choice of R1 and R3: If $V1 < VBIAS$, approximately 1 μA will flow into the on-chip V1 comparator causing a voltage drop. If $V1 \geq VBIAS$, almost no current will flow into the comparator. The voltage drop will require V3P3 to be slightly higher for V1 to cross the VBIAS threshold when V3P3 is rising as compared to when V3P3 is falling. Maintaining sufficient hysteresis helps to eliminate rapid mode changes which may occur in cases where the power supply is unstable with V1 close to the VBIAS threshold point.

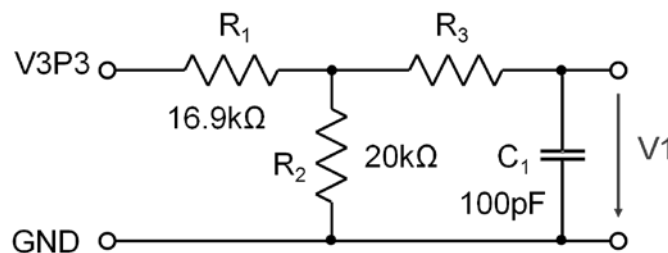

Figure 37: Voltage Divider for V1

3.11 Connecting the Reset Pin

Even though a functional meter will not necessarily need a reset switch, it is useful to have a reset push-button for prototyping as shown in Figure 38, left side. The RESET signal may be sourced from V3P3SYS (functional in MISSION mode only), V3P3D (MISSION and BROWNOUT modes), or VBAT (all modes, if a battery is present), or from a combination of these sources, depending on the application.

For a production meter, the RESET pin should be protected by the external components shown in Figure 38, right side. R1 should be in the range of 100 Ω and mounted as closely as possible to the IC.

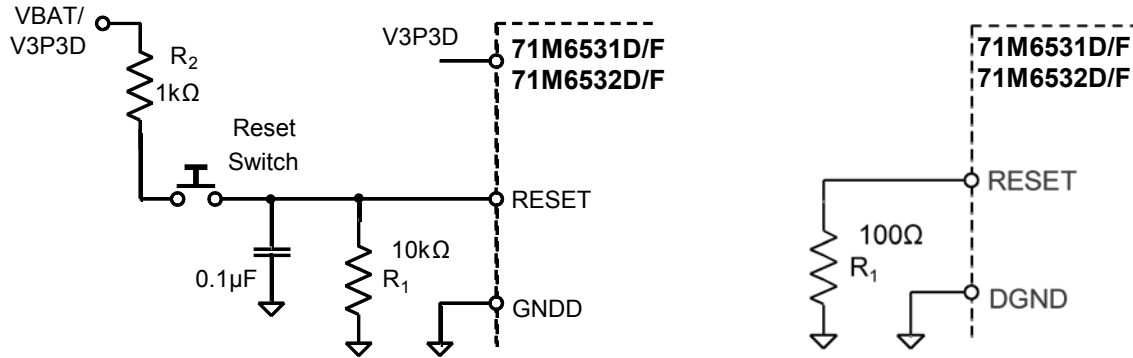

Figure 38: External Components for the RESET Pin: Push-button (Left), Production Circuit (Right)

- Since the 71M6531 generates its own power-on reset, a reset button or circuitry, as shown in Figure 38, is only required for test units and prototypes.

3.12 Connecting the Emulator Port Pins

Even when the emulator is not used, small shunt capacitors to ground (22 pF) should be used for protection from EMI as illustrated in Figure 39. Production boards should have the ICE_E pin connected to ground.

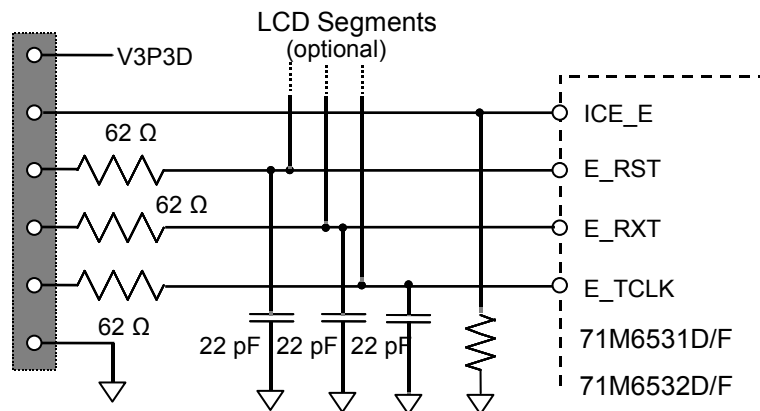

Figure 39: External Components for the Emulator Interface

3.13 Connecting a Battery

It is important that a valid voltage is connected to the VBAT pin at all times. For meters without a battery, VBAT should be connected directly to V3P3SYS. Designs for meters with batteries need to ensure that the meter functions even when the battery voltage decreases below the specified voltage for VBAT. This can be achieved by connecting a diode from V3P3SYS to VBAT. However, the battery test will yield inaccurate results if that technique is used, since the voltage at V3P3SYS will feed current to the VBAT pin. A better solution is shown in Figure 40: During the battery test, a DIO pin is activated as an output and applies a low voltage to the anode of the diode. This prevents the voltage at the power supply to influence the voltage at the VBAT pin.

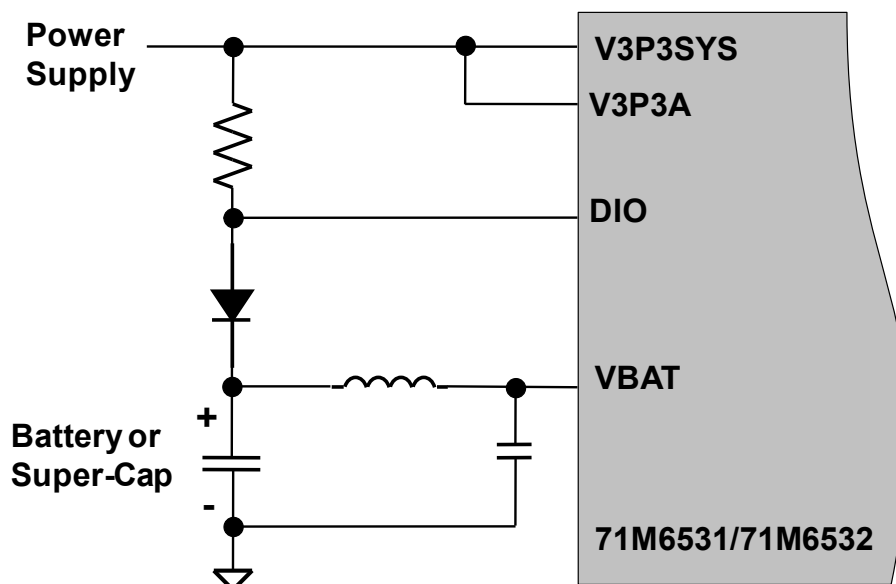

Figure 40: Connecting a Battery



As mentioned in section 2.3, meters equipped with batteries need to contain code that transitions the chip to SLEEP mode as soon as the battery is attached in production. Otherwise, remaining in BROWNOUT mode would add unnecessary drain to the battery.

3.14 Flash Programming

Operational or test code can be programmed into the flash memory using either an in-circuit emulator or the Flash Programmer Module (TFP2) available from Maxim. The flash programming procedure uses the E_RST, E_RXTX and E_TCLK pins. The $FL_BANK[2:0]$ register must be set to the value corresponding to the bank that is being programmed.

3.15 MPU Firmware

All application-specific MPU functions mentioned in the [Application Information](#) section are featured in the demonstration source code supplied by Maxim. The code is available as part of the Demonstration Kit for the 71M6531D/F and 71M6532D/F. The Demonstration Kits come with the 71M6531D/F or 71M6532D/F preprogrammed with demo firmware and mounted on a functional sample meter Demo Board. The Demo Boards allow for quick and efficient evaluation of the IC without having to write firmware or having to supply an in-circuit emulator (ICE).

3.16 Crystal Oscillator

The oscillator drives a standard 32.768 kHz watch crystal. The oscillator has been designed specifically to handle these crystals and is compatible with their high impedance and limited power handling capability. The oscillator power dissipation is very low to maximize the lifetime of any battery backup device attached to VBAT.

Board layouts with minimum capacitance from XIN to XOUT will require less battery current. Good layouts will have XIN and XOUT shielded from each other.



For best rejection of electromagnetic interference, connect the crystal body and the ground terminals of the two crystal capacitors to GNDD through a ferrite bead. No external resistor should be connected across the crystal, since the oscillator is self-biasing.

3.17 Meter Calibration

Once the 71M6531D/F or 71M6532D/F energy meter device has been installed in a meter system, it must be calibrated. A complete calibration includes the following:

- Calibration of the metrology section, i.e. calibration for tolerances of the current sensors, voltage dividers and signal conditioning components as well as of the internal reference voltage (VREF).
- Establishment of the reference temperature (Section 3.3) for temperature measurement and temperature compensation (Section 3.4).
- Calibration of the battery voltage measurement (Section 1.5.13).
- Calibration of the oscillator frequency (Section 1.5.3) and temperature compensation for the RTC (Section 3.4.4).

The metrology section can be calibrated using the gain and phase adjustment factors accessible to the CE. The gain adjustment is used to compensate for tolerances of components used for signal conditioning, especially the resistive components. Phase adjustment is provided to compensate for phase shifts introduced by the current sensors or by the effects of reactive power supplies.

Due to the flexibility of the MPU firmware, any calibration method, such as calibration based on energy, or current and voltage can be implemented. It is also possible to implement segment-wise calibration (depending on current range).

The 71M6531D/F and 71M6532D/F support common industry standard calibration techniques, such as single-point (energy-only), multi-point (energy, Vrms, Irms) and auto-calibration.

4 Firmware Interface

4.1 I/O RAM and SFR Map – Functional Order

In Table 54, unimplemented (U) and reserved (R) bits are shaded in light gray. Unimplemented bits have no memory storage, writing them has no effect, and reading them always returns zero. Reserved bits may be in use and should not be changed from the values given in parentheses. Writing values other than those shown in parenthesis to reserved bits may have undesirable side effects and must be avoided.

Non-volatile bits are shaded in dark gray. Non-volatile bits are backed-up during power failures if the system includes a battery connected to the VBAT pin.

This table lists only the SFR registers that are not generic 8051 SFR registers. Bits marked with † apply to the 71M6531D/F only, bits marked with ‡ apply to the 71M6532D/F only and should be 0 for the other device.

Table 54: I/O RAM Map in Functional Order

Name	Addr	Bit 7	Bit 6	Bit 5	Bit 4	Bit 3	Bit 2	Bit 1	Bit 0	
Configuration:										
CE0	2000	EQU[2:0]			CE_E	CE10MHZ	U			
CE1	2001	PRE_SAMPS[1:0]		SUM_CYCLES[5:0]						
CE2	2002	U		CHOP_E[1:0]		RTM_E	WD_OVF	EX_RTC	EX_XFR	
COMP0	2003	U	PLL_OK	U	U	U	U	U	COMP_STAT	
CONFIG0	2004	VREF_CAL	PLS_INV	U	CKOUT_E	VREF_DIS	MPU_DIV[2:0]			
CONFIG1	2005	U	U	ECK_DIS	M26MHZ	ADC_E	MUX_ALT	U	M40MHZ	
VERSION	2006	VERSION[7:0]								
CONFIG2	2007	OPT_TXE[1:0]		EX_PLL	EX_FWCOL	FIR_LEN[1:0]		OPT_FDC[1:0]		
CE3	209D	U			MUX_DIV[3:0]					
CE4	20A7	BOOT_SIZE[7:0]								
CE5	20A8	CE_LCTN[7:0]								
WAKE	20A9	WAKE_ARM	SLEEP	LCD_ONLY	U	WAKE_RES	WAKE_PRD[2:0]			
TMUX	20AA	U			TMUX[4:0]					
ANACTRL	20AB	R (0000)				LCD_DAC[2:0]			CHOP_I_EN†	
CONFIG3	20AC	U	SEL_IBN‡	CHOP_IB‡	U	SEL_IAN‡	CHOP_IA‡			
CONFIG4	20AD	U	R (0)		R (0)	U	R (0)		R (0)	
Interrupts and WD Timer:										
INTBITS	SFR F8	WD_RST	INT6	INT5	INT4	INT3	INT2	INT1	INT0	
IFLAGS	SFR E8	IE_PLLFALL	IE_PLLRISE	IE_WAKE	IE_PB	IE_FWCOL1	IE_FWCOL0	IE_RTC	IE_XFER	
Flash Memory:										
ERASE	SFR 94	FLSH_ERASE[7:0]								
FLSHCTL	SFR B2	PREBOOT	SECURE	WRPROT_BT	WRPROT_CE	U		FLSH_MEEN	FLSH_PWE	
FL_BANK	SFR B6	U					FLBANK[2:0]			
PGADR	SFR B7	FLSH_PGADR[5:0]						U		

Name	Addr	Bit 7	Bit 6	Bit 5	Bit 4	Bit 3	Bit 2	Bit 1	Bit 0	
Digital I/O:										
	20AF	U					DIO_RRX[2:0]			
DIO0	2008	DIO_EEX[1:0]		OPT_RXDIS	OPT_RXINV	DIO_PW	DIO_PV	OPT_TXMOD	OPT_TXINV	
DIO1	2009	U	DIO_R1[2:0]†			U	DI_RPB[2:0]			
DIO2	200A	U	U			U	DIO_R2[2:0]			
DIO3	200B	U	DIO_R5[2:0]			U	DIO_R4[2:0]			
DIO4	200C	U	DIO_R7[2:0]			U	DIO_R6[2:0]			
DIO5	200D	U	DIO_R9[2:0]			U	DIO_R8[2:0]			
DIO6	200E	U	DIO_R11[2:0]			U	DIO_R10[2:0]			
	200F	R(0)	R(0)	U		DIO_PX	DIO_PY	U		
DIO7	SFR 80	DIO_0[7:1]							DIO_0[0]†	
DIO8	SFR A2	DIO_DIR0[7:1]							DIO_DIR0[0]†	
DIO9	SFR 90	DIO_1[7:0] (Port 1)								
DIO10	SFR 91	DIO_DIR1[7:0]								
DIO11	SFR A0	DIO_2[7]‡	DIO_2[6]‡	DIO_2[5]‡	DIO_2[4] ‡	DIO_2[3] ‡	DIO_2[2] ‡	DIO_2[1]	DIO_2[0]‡	
DIO12	SFR A1	DIO_DIR2[7] ‡	DIO_DIR2[6] ‡	DIO_DIR2[5] ‡	DIO_DIR2[4] ‡	DIO_DIR2[3] ‡	DIO_DIR2[2] ‡	DIO_DIR2[1]	DIO_DIR2[0] ‡	
DIO13	SFR B0	R(0)	DIO_3[6]‡	DIO_3[5]	DIO_3[4]†	DIO_3[3] ‡	DIO_3[2] ‡	DIO_3[1] ‡	DIO_3[0] ‡	
Real Time Clock:										
RTCCTRL	2010	U							RST_SUBSEC	
RTCA_ADJ	2011	U	RTCA_ADJ[6:0]							
SUBSEC1	2014	SUBSEC[7:0]								
RTC0	2015	U	RTC_SEC[5:0]							
RTC1	2016	U	RTC_MIN[5:0]							
RTC2	2017	U			RTC_HR[4:0]					
RTC3	2018	U					RTC_DAY[2:0]			
RTC4	2019	U				RTC_DATE[2:0]				
RTC5	201A	U				RTC_MO[3:0]				
RTC6	201B	RTC_YR[7:0]								
RTCADJ_H	201C	U					PREG[16:14]			
RTCADJ_M	201D	PREG[13:6]								
RTCADJ_L	201E	PREG[5:0]						QREG[1:0]		
WE	201F	RTC write protect register								

Name	Addr	Bit 7	Bit 6	Bit 5	Bit 4	Bit 3	Bit 2	Bit 1	Bit 0	
LCD Display Interface:										
LCDX	2020	MUX_SYNC_E	BME	R (0)	R (0)	U				
LCDY	2021	U	LCD_Y	LCD_E	LCD_MODE[2:0]			LCD_CLK[1:0]		
LCD_MAP0	2023	LCD_BITMAP[31:24]								
LCD_MAP1	2024	LCD_BITMAP [39]‡	LCD_BITMAP [38]‡	LCD_BITMAP [37]	LCD_BITMAP [36]‡	LCD_BITMAP [35]	LCD_BITMAP [34]	LCD_BITMAP [33]	LCD_BITMAP [32]	
LCD_MAP2	2025	LCD_BITMAP[47:40]‡								
LCD_MAP3	2026	U					LCD_BITMAP [50]‡	LCD_BITMAP [49]	LCD_BITMAP [48]†	
LCD_MAP4	2027	LCD_BITMAP [63]	LCD_BITMAP [62]‡	LCD_BITMAP [61]‡	LCD_BITMAP [60]‡	U				
LCD_MAP5	2028	LCD_BITMAP [71]‡	LCD_BITMAP [70]‡	LCD_BITMAP [69]‡	LCD_BITMAP [68]‡	LCD_BITMAP [67]‡	LCD_BITMAP [66]†	LCD_BITMAP [65]	LCD_BITMAP [64]	
LCD_MAP6	2029	U								
LCD0	2030	LCD_SEG42[3:0]‡				LCD_SEG0[3:0]				
LCD1	2031	LCD_SEG43[3:0]‡				LCD_SEG1[3:0]				
LCD2	2032	U				LCD_SEG2[3:0]				
LCD3	2033	LCD_SEG45[3:0]‡				LCD_SEG3[3:0]				
LCD4	2034	LCD_SEG46[3:0]‡				LCD_SEG4[3:0]				
LCD5	2035	LCD_SEG47[3:0]‡				LCD_SEG5[3:0]				
LCD6	2036	LCD_SEG48[3:0]†				LCD_SEG6[3:0]†				
LCD7	2037	LCD_SEG49[3:0]				LCD_SEG7[3:0]				
LCD8	2038	LCD_SEG50[3:0]‡				LCD_SEG8[3:0]				
LCD9	2039	U				LCD_SEG9[3:0]				
...				
LCD17	2041	U				LCD_SEG17[3:0]				
LCD18	2042	LCD_SEG60[3:0]‡				LCD_SEG18[3:0]				
LCD19	2043	LCD_SEG61[3:0]‡				LCD_SEG19[3:0]				
LCD20	2044	LCD_SEG62[3:0]‡				LCD_SEG20[3:0]‡				
LCD21	2045	LCD_SEG63[3:0]				LCD_SEG21[3:0]‡				
LCD22	2046	LCD_SEG64[3:0]				LCD_SEG22[3:0]‡				
LCD23	2047	LCD_SEG65[3:0]				LCD_SEG23[3:0]‡				
LCD24	2048	LCD_SEG66[3:0]†				LCD_SEG24[3:0]				
LCD25	2049	LCD_SEG67[3:0]‡				LCD_SEG25[3:0]				
LCD26	204A	LCD_SEG68[3:0]‡				LCD_SEG26[3:0]				

Name	Addr	Bit 7	Bit 6	Bit 5	Bit 4	Bit 3	Bit 2	Bit 1	Bit 0	
LCD27	204B	LCD_SEG69[3:0]‡				LCD_SEG27[3:0]‡				
LCD28	204C	LCD_SEG70[3:0]‡				LCD_SEG28[3:0]				
LCD29	204D	LCD_SEG71[3:0]‡				LCD_SEG29[3:0]				
LCD30	204E	U				LCD_SEG30[3:0]				
...				
LCD33	2053	U				LCD_SEG35[3:0]				
LCD36	2054	U				LCD_SEG36[3:0]‡				
LCD37	2055	U				LCD_SEG37[3:0]				
LCD38	2056	U				LCD_SEG38[3:0]‡				
...				
LCD41	2059	U				LCD_SEG41[3:0]‡				
LCD_BLNK	205A	LCD_BLKMAP19[3:0]				LCD_BLKMAP18[3:0]				
RTM:										
RTM0H	2060	U				RTM0[9:8]				
RTM0L	2061	RTM0[7:0]								
RTM1H	2062	U				RTM1[9:8]				
RTM1L	2063	RTM1[7:0]								
RTM2H	2064	U				RTM2[9:8]				
RTM2L	2065	RTM2[7:0]								
RTM3H	2066	U				RTM3[9:8]				
RTM3L	2067	RTM3[7:0]								
SPI Interface:										
SPI...	2070	SPE	U							
SP_CMD	2071	SP_CMD[7:0]								
SP_ADH	2072	SP_ADDR[15:8]								
SP_ADL	2073	SP_ADDR[7:0]								
Pulse Generator:										
PLS_W	2080	PLS_MAXWIDTH[7:0]								
PLS_I	2081	PLS_INTERVAL[7:0]								
ADC MUX:										
SLOT0	2090	SLOT1_SEL				SLOT0_SEL				
SLOT1	2091	SLOT3_SEL				SLOT2_SEL				
SLOT2	2092	R				R				
SLOT3	2093	R				R				
SLOT4	2094	R				R				

Name	Addr	Bit 7	Bit 6	Bit 5	Bit 4	Bit 3	Bit 2	Bit 1	Bit 0
<i>SLOT5</i>	2096	<i>SLOT1_ALTSEL</i>				<i>SLOT0_ALTSEL</i>			
<i>SLOT6</i>	2097	<i>SLOT3_ALTSEL</i>				<i>SLOT2_ALTSEL</i>			
<i>SLOT7</i>	2098	R				R			
<i>SLOT8</i>	2099	R				R			
<i>SLOT9</i>	209A	R				R			
SPI Interrupt:									
<i>SPI0</i>	20B0	U			<i>IEN_SPI</i>	U			<i>IEN_WD_NROVF</i>
<i>SPI1</i>	20B1	U			<i>SPI_FLAG</i>	U			<i>WD_NROVF_FLAG</i>
General-Purpose Nonvolatile Registers:									
<i>GP0</i>	20C0	<i>GPO[7:0]</i>							
...							
<i>GP7</i>	20C7	<i>GP7[7:0]</i>							
<i>VERSION</i>	20C8	<i>VERSION[7:0]</i>							
Serial EEPROM:									
<i>EEDATA</i>	SFR 9E	<i>EEDATA[7:0]</i>							
<i>EECTRL</i>	SFR 9F	<i>EECTRL[7:0]</i>							

† 71M6531D/F only

‡ 71M6532D/F only

4.2 I/O RAM Description – Alphabetical Order

The following conventions apply to the descriptions in this table:

- Bits with a W (write) direction are written by the MPU into configuration RAM. Typically, they are initially stored in flash memory and copied to the configuration RAM by the MPU. Some of the more frequently programmed bits are mapped to the MPU SFR memory space. The remaining bits are mapped to 2xxx.
- Bits with a R (read) direction can be read by the MPU.
- Columns labeled Reset and Wake describe the bit values upon reset and wake, respectively. “NV” in the Wake column means the bit is powered by the nonvolatile supply and is not initialized. LCD-related registers labeled “L” retain data upon transition from LCD mode to BROWNOUT mode and vice versa, but do not retain data in SLEEP mode. “–” means that the value is undefined.
- Write-only bits will return zero when they are read.

Table 55: I/O RAM Description - Alphabetical

Name	Location	Reset	Wake	Dir	Description
<i>ADC_E</i>	2005[3]	0	0	R/W	Enables ADC and VREF. When disabled, removes bias current.
<i>BME</i>	2020[6]	0	–	R/W	Battery Measure Enable. When set, a load current is immediately applied to the battery and it is connected to the ADC to be measured on Alternative Mux Cycles. See the <i>MUX_ALT</i> bit.
<i>BOOT_SIZE[7:0]</i>	20A7[7:0]	01	01	R/W	End of space reserved for boot program. The ending address of the boot region is $1024 * \text{BOOT_SIZE}$.
<i>CE10MHZ</i>	2000[3]	0	0	R/W	CE clock select. When set, the CE is clocked at 10 MHz. Otherwise, the CE clock frequency is 5 MHz.
<i>CE_E</i>	2000[4]	0	0	R/W	CE enable.
<i>CE_LCTN[7:0]</i>	20A8[4:0]	31	31	R/W	CE program location. The starting address for the CE program is $1024 * \text{CE_LCTN}$.
<i>CHOP_E[1:0]</i>	2002[5:4]	0	0	R/W	Chop enable for the reference bandgap circuit. The value of CHOP will change on the rising edge of MUXSYNC according to the value in <i>CHOP_E[1:0]</i> : 00 = toggle, except at the mux sync edge at the end of SUMCYCLE, an alternative MUX frame is automatically inserted at the end of each accumulation interval. 01 = positive. 10 = reversed. 11 = toggle, no alternative MUX frame is inserted
<i>CHOP_IA</i>	20AC[0]	0	0	R/W	This bit enables chop mode for the IA current channel (71M6532D/F only). <i>CHOP_I_E</i> must be set also.
<i>CHOP_IB</i>	20AC[4]	0	0	R/W	This bit enables chop mode for the IB current channel (71M6532D/F only). <i>CHOP_I_E</i> must be set also.
<i>CHOP_I_E</i>	20AB[0]	0	0	R/W	This bit must be set to enable chop mode for the current channels (71M6532D/F only).

Name	Location	Reset	Wake	Dir	Description																											
<i>CKOUT_E</i>	2004[4]	0	0	R/W	Control bit for the SEG19/CKOUT pin: 0: The pin is the SEG19 LCD driver 1: The pin is the CK_FIR output (5 MHz in mission mode, 32 kHz in BROWNOUT mode)																											
<i>COMPSTAT</i>	2003[0]	–	–	R	Status bit for the V1 comparator (same as V1_OK, see TMUXOUT).																											
<i>DI_RPB[2:0]</i> <i>DIO_R1[2:0]</i> <i>DIO_R2[2:0]</i> <i>DIO_R4[2:0]</i> <i>DIO_R5[2:0]</i> <i>DIO_R6[2:0]</i> <i>DIO_R7[2:0]</i> <i>DIO_R8[2:0]</i> <i>DIO_R9[2:0]</i> <i>DIO_R10[2:0]</i> <i>DIO_R11[2:0]</i> <i>DIO_RRX[2:0]</i>	2009[2:0] 2009[6:4] 200A[2:0] 200B[2:0] 200B[6:4] 200C[2:0] 200C[6:4] 200D[2:0] 200D[6:4] 200E[2:0] 200E[6:4] 20AF[2:0]	0 0 0 0 0 0 0 0 0 0 0 0	0 0 0 0 0 0 0 0 0 0 0 0	R/W	Connects dedicated I/O pins DIO2 and DIO4 through DIO11 as well as input pins PB, DIO1 and RX to internal resources. If more than one input is connected to the same resource, the Multiple column in the table below specifies how they are combined. <table border="1" data-bbox="886 464 1703 834"> <thead> <tr> <th><i>DIO_Rx[2:0]</i></th> <th>Resource</th> <th>Multiple</th> </tr> </thead> <tbody> <tr> <td>000</td> <td>NONE</td> <td>–</td> </tr> <tr> <td>001</td> <td>Reserved</td> <td>OR</td> </tr> <tr> <td>010</td> <td>T0 (Counter /Timer 0 clock or gate)</td> <td>OR</td> </tr> <tr> <td>011</td> <td>T1 (Counter /Timer 1 clock or gate)</td> <td>OR</td> </tr> <tr> <td>100</td> <td>High priority IO interrupt (int0 rising)</td> <td>OR</td> </tr> <tr> <td>101</td> <td>Low priority IO interrupt (int1 rising)</td> <td>OR</td> </tr> <tr> <td>110</td> <td>High priority IO interrupt (int0 fall-ing)</td> <td>OR</td> </tr> <tr> <td>111</td> <td>Low priority IO interrupt (int1 falling)</td> <td>OR</td> </tr> </tbody> </table>	<i>DIO_Rx[2:0]</i>	Resource	Multiple	000	NONE	–	001	Reserved	OR	010	T0 (Counter /Timer 0 clock or gate)	OR	011	T1 (Counter /Timer 1 clock or gate)	OR	100	High priority IO interrupt (int0 rising)	OR	101	Low priority IO interrupt (int1 rising)	OR	110	High priority IO interrupt (int0 fall-ing)	OR	111	Low priority IO interrupt (int1 falling)	OR
<i>DIO_Rx[2:0]</i>	Resource	Multiple																														
000	NONE	–																														
001	Reserved	OR																														
010	T0 (Counter /Timer 0 clock or gate)	OR																														
011	T1 (Counter /Timer 1 clock or gate)	OR																														
100	High priority IO interrupt (int0 rising)	OR																														
101	Low priority IO interrupt (int1 rising)	OR																														
110	High priority IO interrupt (int0 fall-ing)	OR																														
111	Low priority IO interrupt (int1 falling)	OR																														
<i>DIO_DIR0[7:1]</i>	SFR A2 [7:1]	0	–	R/W	Programs the direction of DIO pins 7 through 1. 1 indicates an output. The bits are ignored if the pin is not configured as DIO. See <i>DIO_PV</i> and <i>DIO_PW</i> for special options for DIO6 and DIO7. See <i>DIO_EEX[1:0]</i> for special options for DIO4 and DIO5.																											
<i>DIO_DIR1[7:0]</i>	SFR 91	0	–	R/W	Programs the direction of DIO pins 15 through 8. 1 indicates an output. The bits are ignored if the pin is not configured as I/O. See <i>DIO_PX</i> and <i>DIO_PW</i> for special options for the DIO8 and DIO9 outputs.																											
<i>DIO_DIR2[1]</i>	SFR A1[1]	0	–	R/W	Programs the direction of DIO17.																											
<i>DIO_0[7:0]</i> <i>DIO_1[7:0]</i> <i>DIO_2[1]</i> <i>DIO_3[5:4]</i>	SFR 80 SFR 90 SFR A0[1] SFR B0[5:4]	0 0 0 0	– – – –	R/W R/W R/W R/W	The value on the DIO pins. Pins configured as LCD will read zero. When written, changes data on pins configured as outputs. Pins configured as LCD or input will ignore writes. <i>DIO_0[7:1]</i> corresponds to DIO7 through DIO1. PB is read on <i>DIO_0[0]</i> . <i>DIO_1[7:0]</i> corresponds to DIO15 through DIO8. <i>DIO_2[1]</i> corresponds to DIO17. <i>DIO_3[5:4]</i> corresponds to DIO28 and DIO29.																											

Name	Location	Reset	Wake	Dir	Description				
<i>DIO_EEX[1:0]</i>	2008[7:6]	0	0	R/W	When set, converts DIO4 and DIO5 to interface with external EEPROM. DIO4 becomes SDCK and DIO5 becomes bi-directional SDATA.				
					<i>DIO_EEX[1:0]</i>	Function			
					00	Disable EEPROM interface			
					01	2-Wire EEPROM interface			
					10	3-Wire EEPROM interface			
11	not used								
<i>DIO_PV</i>	2008[2]	0	0	R/W	Causes VARPULSE to be output on DIO7.				
<i>DIO_PW</i>	2008[3]	0	0	R/W	Causes WPULSE to be output on DIO6.				
<i>DIO_PX</i>	200F[3]	0	0	R/W	Causes XPULSE to be output on DIO8.				
<i>DIO_PY</i>	200F[2]	0	0	R/W	Causes YPULSE to be output on DIO9.				
<i>EEDATA[7:0]</i>	SFR 9E	0	0	R/W	Serial EEPROM interface data.				
<i>EECTRL[7:0]</i>	SFR 9F	0	0	R/W	Serial EEPROM interface control.				
<i>ECK_DIS</i>	2005[5]	0	0	R/W	Emulator clock disable. When <i>ECK_DIS</i> = 1, the emulator clock is disabled.  If <i>ECK_DIS</i> is set, the emulator and programming devices will be unable to erase or program the device.				
<i>EQU[2:0]</i>	2000[7:5]	0	0	R/W	Specifies the power equation to be used by the CE.				
<i>EX_XFR</i>	2002[0]	0	0	R/W	Interrupt enable bits. These bits enable the XFER_BUSY, the RTC_1SEC, the FirmWareCollision (FWCOL) and PLL interrupts. Note that if one of these interrupts is to be enabled, its corresponding MPU EX enable must also be set. See Section 1.4.9 Interrupts for details.				
<i>EX_RTC</i>	2002[1]	0	0						
<i>EX_FWCOL</i>	2007[4]	0	0						
<i>EX_PLL</i>	2007[5]	0	0						
<i>FIR_LEN[1:0]</i>	2007[3:2]	1	1	R/W	<i>FIR_LEN[1:0]</i> controls the length of the ADC decimation FIR filter and therefore controls the time taken for each conversion.				
					<i>[M40MHZ, M26MHZ]</i>	<i>FIR_LEN[1:0]</i>	Resulting FIR Filter Cycles	Resulting CK32 Cycles	Resulting DC Gain
					[00], [10], or [11]	00	138	1	0.110017
						01	288	2	1.000
						10	384	3	2.37037
					[01]	00	186	1	0.113644
						01	384	2	1.000
10	588	3	3.590363						
<i>FL_BANK[2:0]</i>	SFR B6[2:0]	1	1	R/W	Flash bank. Memory above 32 KB is mapped to the MPU address space from 0x8000 to 0xFFFF in 32 KB banks. When MPU address[15] = 1, the address in flash is mapped to <i>FL_BANK[2:0]</i> , MPU Address[14:0]. <i>FL_BANK</i> is reset by the erase cycle.				

Name	Location	Reset	Wake	Dir	Description
<i>FLSH_ERASE</i> [7:0]	SFR 94[7:0]	0	0	W	Flash Erase Initiate. (Default = 0x00). <i>FLSH_ERASE</i> is used to initiate either the Flash Mass Erase cycle or the Flash Page Erase cycle. Specific patterns are expected for <i>FLSH_ERASE</i> in order to initiate the appropriate Erase cycle. 0x55 = Initiate Flash Page Erase cycle. Must be preceded by a write to <i>FLSH_PGADR</i> [5:0] @ SFR 0xB7. 0xAA = Initiate Flash Mass Erase cycle. Must be preceded by a write to <i>FLSH_MEEN</i> @ SFR 0xB2 and the debug (CC) port must be enabled. Any other pattern written to <i>FLSH_ERASE</i> will have no effect. The erase cycle is not completed until 0x00 is written to <i>FLSH_ERASE</i> .
<i>FLSH_MEEN</i>	SFR B2[1]	0	0	W	Mass Erase Enable. 0 = Mass Erase disabled (default). 1 = Mass Erase enabled. Must be re-written for each new Mass Erase cycle.
<i>FLSH_PGADR</i> [5:0]	SFR B7 [7:2]	0	0	W	Flash Page Erase Address. (Default = 0x00) <i>FLSH_PGADR</i> [5:0] with <i>FL_BANK</i> [2:0], sets the Flash Page Address (page 0 through 127) that will be erased during the Page Erase cycle. Must be re-written for each new Page Erase cycle.
<i>FLSH_PWE</i>	SFR B2[0]	0	0	R/W	Program Write Enable. This bit must be cleared by the MPU after each byte write operation. Write operations to this bit are inhibited when interrupts are enabled. 0 = MOVX commands refer to XRAM Space, normal operation (default). 1 = MOVX @DPTR,A moves A to Program Space (Flash) @ DPTR.
<i>GP0</i> ... <i>GP7</i>	20C0 ... 20C7	0 ... 0	NV ... NV	R/W	Non-volatile general-purpose registers powered by the RTC supply. These registers maintain their value in all power modes, but will be cleared on reset. The values of GP0...GP7 will be undefined if VBAT drops below the minimum value.
<i>IE_FWCOL0</i> <i>IE_FWCOL1</i>	SFR E8[2] SFR E8[3]	0 0	0 0	R/W R/W	Interrupt flags for Firmware Collision Interrupt. See the Flash Memory section for details.
<i>IE_PB</i>	SFR E8[4]	0	–	R/W	PB flag. Indicates that a rising edge occurred on PB. Firmware must write a zero to this bit to clear it. The bit is also cleared when the MPU requests SLEEP or LCD mode. On bootup, the MPU can read this bit to determine if the part was woken with the PB (DIO0[0]).
<i>IE_PLLRISE</i>	SFR E8[6]	0	0	R/W	Indicates that the MPU was woken or interrupted (INT4) by system power becoming available, or more precisely, by PLL_OK rising. The firmware must write a zero to this bit to clear it.
<i>IE_PLLFALL</i>	SFR E8[7]	0	0	R/W	Indicates that the MPU has entered BROWNOUT mode because system power has become unavailable (INT4), or more precisely, because PLL_OK fell. This bit will not be set if the part wakes into BROWNOUT mode because of PB or the WAKE timer. The firmware must write a zero to this bit to clear it.
<i>IEN_SPI</i>	20B0[4]	0	–	R/W	SPI interrupt enable.

Name	Location	Reset	Wake	Dir	Description
<i>IEN_WD_NROVF</i>	20B0[0]	0	0	R/W	Active high watchdog near overflow interrupt enable.
<i>IE_XFER</i> <i>IE_RTC</i>	SFR E8[0] SFR E8[1]	0 0	0 0	R/W	Interrupt flags. These flags monitor the XFER_BUSY interrupt and the RTC_1SEC interrupt. The flags are set by hardware and clear automatically.
<i>IE_WAKE</i>	SFR E8[5]	0	–	R/W	Indicates that the MPU was awakened by the autowake timer. This bit is typically read by the MPU on bootup. The firmware must write a zero to this bit to clear it.
<i>INTBITS</i>	SFR F8[6:0]	–	–	R/W	Interrupt inputs. The MPU may read these bits to see the status of external interrupts INT0, INT1 up to INT6. These bits do not have any memory and are primarily intended for debug use.
<i>LCD_BITMAP</i> [31:24]	2023	0	L	R/W	Configuration for DIO11/SEG31 through DIO4/SEG24. Unused bits should be set to zero. 1 = LCD pin, 0 = DIO pin. Check Table 54 for bit availability.
<i>LCD_BITMAP</i> [39:32]	2024	0	L	R/W	Bitmap of DIO19/SEG39 through DIO12/SEG32. Unused bits should be set to zero. 1 = LCD pin, 0 = DIO pin. Check Table 54 for bit availability.
<i>LCD_BITMAP</i> [55:48]	2026	0	L	R/W	Bitmap of DIO28/SEG48 through DIO35/SEG55. Unused bits should be set to zero. 1 = LCD pin, 0 = DIO pin. Check Table 54 for bit availability.
<i>LCD_BITMAP</i> [63:56]	2027	0	L	R/W	Bitmap of DIO36/SEG56 through DIO43/SEG63. Unused bits should be set to zero. 1 = LCD pin, 0 = DIO pin. Check Table 54 for bit availability.
<i>LCD_BITMAP</i> [71:64]	2028	0	L	R/W	Bitmap of DIO44/SEG64 through DIO51/SEG71. Unused bits should be set to zero. 1 = LCD pin, 0 = DIO pin. Check Table 54 for bit availability.
<i>LCD_BLKMAP19</i> [3:0] <i>LCD_BLKMAP18</i> [3:0]	205A[7:4] 205A[3:0]	0	L	R/W	Identifies which segments connected to SEG18 and SEG19 should blink. 1 means blink. The most significant bit corresponds to COM3, the least significant bit to COM0.
<i>LCD_CLK</i> [1:0]	2021[1:0]	0	L	R/W	Sets the LCD clock frequency for COM/SEG pins (<u>not</u> frame rate) according to the following ($f_w = 32768$ Hz): 00 = $f_w/2^9$ 01 = $f_w/2^8$ 10 = $f_w/2^7$ 11 = $f_w/2^6$

Name	Location	Reset	Wake	Dir	Description																		
<i>LCD_DAC[2:0]</i>	20AB[3:1]	0	L	R/W	<p>LCD contrast control DAC. Adjusts the LCD voltage in steps of 0.2 V from V3P3SYS (mission mode) or VBAT (BROWNOUT/LCD modes).</p> <table border="1"> <thead> <tr> <th><i>LCD_DAC[2:0]</i></th> <th>Resulting LCD Voltage</th> </tr> </thead> <tbody> <tr> <td>000</td> <td>V3P3 or VBAT</td> </tr> <tr> <td>001</td> <td>V3P3 or VBAT – 0.2V</td> </tr> <tr> <td>010</td> <td>V3P3 or VBAT – 0.4V</td> </tr> <tr> <td>011</td> <td>V3P3 or VBAT – 0.6V</td> </tr> <tr> <td>100</td> <td>V3P3 or VBAT – 0.8V</td> </tr> <tr> <td>101</td> <td>V3P3 or VBAT – 1.0V</td> </tr> <tr> <td>110</td> <td>V3P3 or VBAT – 1.2V</td> </tr> <tr> <td>111</td> <td>V3P3 or VBAT – 1.4V</td> </tr> </tbody> </table>	<i>LCD_DAC[2:0]</i>	Resulting LCD Voltage	000	V3P3 or VBAT	001	V3P3 or VBAT – 0.2V	010	V3P3 or VBAT – 0.4V	011	V3P3 or VBAT – 0.6V	100	V3P3 or VBAT – 0.8V	101	V3P3 or VBAT – 1.0V	110	V3P3 or VBAT – 1.2V	111	V3P3 or VBAT – 1.4V
<i>LCD_DAC[2:0]</i>	Resulting LCD Voltage																						
000	V3P3 or VBAT																						
001	V3P3 or VBAT – 0.2V																						
010	V3P3 or VBAT – 0.4V																						
011	V3P3 or VBAT – 0.6V																						
100	V3P3 or VBAT – 0.8V																						
101	V3P3 or VBAT – 1.0V																						
110	V3P3 or VBAT – 1.2V																						
111	V3P3 or VBAT – 1.4V																						
<i>LCD_E</i>	2021[5]	0	L	R/W	Enables the LCD display. When disabled, VLC2, VLC1 and VLC0 are ground as are the COM and SEG outputs.																		
<i>LCD_MODE[2:0]</i>	2021[4:2]	0	L	R/W	<p>The LCD bias mode. Use the LCD DAC in ANACTRL to reduce saturation. The number of states is the number of commons which are driven to multiplex the LCD.</p> <table border="1"> <thead> <tr> <th><i>LCD_MODE[2:0]</i></th> <th>Function</th> <th>Notes</th> </tr> </thead> <tbody> <tr> <td>000</td> <td>4 states, $\frac{1}{3}$ bias</td> <td rowspan="2">$\frac{1}{3}$ bias modes can drive 3.3 V LCDs.</td> </tr> <tr> <td>001</td> <td>3 states, $\frac{1}{3}$ bias</td> </tr> <tr> <td>010</td> <td>2 states, $\frac{1}{2}$ bias</td> <td rowspan="3">$\frac{1}{2}$ bias and static modes can drive both 3.3 V and 5 V LCDs.</td> </tr> <tr> <td>011</td> <td>3 states, $\frac{1}{2}$ bias</td> </tr> <tr> <td>100</td> <td>static display</td> </tr> </tbody> </table>	<i>LCD_MODE[2:0]</i>	Function	Notes	000	4 states, $\frac{1}{3}$ bias	$\frac{1}{3}$ bias modes can drive 3.3 V LCDs.	001	3 states, $\frac{1}{3}$ bias	010	2 states, $\frac{1}{2}$ bias	$\frac{1}{2}$ bias and static modes can drive both 3.3 V and 5 V LCDs.	011	3 states, $\frac{1}{2}$ bias	100	static display			
<i>LCD_MODE[2:0]</i>	Function	Notes																					
000	4 states, $\frac{1}{3}$ bias	$\frac{1}{3}$ bias modes can drive 3.3 V LCDs.																					
001	3 states, $\frac{1}{3}$ bias																						
010	2 states, $\frac{1}{2}$ bias	$\frac{1}{2}$ bias and static modes can drive both 3.3 V and 5 V LCDs.																					
011	3 states, $\frac{1}{2}$ bias																						
100	static display																						
<i>LCD_ONLY</i>	20A9[5]	0	0	W	Puts the part to sleep, but with the LCD display still active. <i>LCD_ONLY</i> is ignored if system power is present. While in SLEEP mode, the device will wake up on reset, when the autowake timer times out, when the push button is pushed, or when system power returns.																		
<i>LCD_SEG0[3:0]</i> ... <i>LCD_SEG19[3:0]</i>	2030[3:0] ... 2043[3:0]	0 ... 0	L ... L	R/W ... R/W	<p>LCD Segment Data. Each word contains information for 1 to 4 time divisions of each segment. Some addresses are used to address two segments.</p> <p>In each word, bit 0 corresponds to COM0, bit 1 to COM1, bit 2 to COM2 and bit 3 to COM3 of the first segment. Bits 4 through 7 correspond to COM0 to COM3, respectively, of the second segment.</p> <p>Care should be taken when writing to <i>LCD_SEG</i> locations since some of them control DIO pins.</p>																		
<i>LCD_SEG24[3:0]</i> ... <i>LCD_SEG31[3:0]</i>	2048[3:0] ... 204F[3:0]	0 ... 0	L ... L	R/W ... R/W																			
<i>LCD_SEG32[3:0]</i>	2050[3:0]	0	L	R/W																			

Name	Location	Reset	Wake	Dir	Description																		
<i>LCD_SEG33</i> [3:0]	2051[3:0]	0	L	R/W																			
...																			
<i>LCD_SEG35</i> [3:0]	2053[3:0]	0	L	R/W																			
<i>LCD_SEG37</i> [3:0]	2055[3:0]	0	L	R/W																			
<i>LCD_SEG39</i> [3:0]	2057[3:0]	0	L	R/W																			
...																			
<i>LCD_SEG41</i> [3:0]	2059[3:0]	0	L	R/W																			
<i>LCD_SEG48</i> [7:4]	2036[7:4]	0	L	R/W																			
...																			
<i>LCD_SEG49</i> [7:4]	2037[7:4]	0	L	R/W																			
<i>LCD_SEG63</i> [7:4]	2045[7:4]	0	L	R/W																			
...																			
<i>LCD_SEG66</i> [7:4]	2048[7:4]	0	L	R/W																			
<i>LCD_SEG71</i> [7:4]	204D[7:4]	0	L	R/W																			
...																			
<i>LCD_SEG73</i> [7:4]	204F[7:4]	0	L	R/W																			
<i>LCD_Y</i>	2021[6]	0	L	R/W	LCD Blink Frequency (ignored if blink is disabled or if the segment is off). 0 = 1 Hz (500 ms ON, 500 ms OFF) 1 = 0.5 Hz (1 s ON, 1 s OFF)																		
<i>M26MHZ</i> <i>M40MHZ</i>	2005[4] 2005[0]	0 0	0 0	R/W R/W	<i>M26MHZ</i> and <i>M40MHZ</i> set the master clock (MCK) frequency. These bits are reset on chip reset and may only be set. Attempts to write zeroes to <i>M40MHZ</i> and <i>M26MHZ</i> are ignored.																		
<i>MPU_DIV</i> [2:0]	2004[2:0]	0	0	R/W	The MPU clock divider (from MCK). These bits may be programmed by MPU without risk of losing control.																		
					<table border="1"> <thead> <tr> <th><i>MPU_DIV</i>[2:0]</th> <th>Resulting Clock Frequency</th> </tr> </thead> <tbody> <tr> <td>000</td> <td>$MCK/2^2$</td> </tr> <tr> <td>001</td> <td>$MCK/2^3$</td> </tr> <tr> <td>010</td> <td>$MCK/2^4$</td> </tr> <tr> <td>011</td> <td>$MCK/2^5$</td> </tr> <tr> <td>100</td> <td>$MCK/2^6$</td> </tr> <tr> <td>101</td> <td>$MCK/2^7$</td> </tr> <tr> <td>110</td> <td>$MCK/2^8$</td> </tr> <tr> <td>111</td> <td>$MCK/2^8$</td> </tr> </tbody> </table>	<i>MPU_DIV</i> [2:0]	Resulting Clock Frequency	000	$MCK/2^2$	001	$MCK/2^3$	010	$MCK/2^4$	011	$MCK/2^5$	100	$MCK/2^6$	101	$MCK/2^7$	110	$MCK/2^8$	111	$MCK/2^8$
					<i>MPU_DIV</i> [2:0]	Resulting Clock Frequency																	
					000	$MCK/2^2$																	
					001	$MCK/2^3$																	
					010	$MCK/2^4$																	
					011	$MCK/2^5$																	
					100	$MCK/2^6$																	
					101	$MCK/2^7$																	
110	$MCK/2^8$																						
111	$MCK/2^8$																						

Name	Location	Reset	Wake	Dir	Description										
<i>MUX_ALT</i>	2005[2]	0	0	R/W	The MPU asserts this bit when it wishes the MUX to perform ADC conversions on an alternate set of inputs. If <i>CHOP_E[1:0]</i> is 00, <i>MUX_ALT</i> is automatically asserted once per sumcycle, when <i>XFER_BUSY</i> falls.										
<i>MUX_DIV[3:0]</i>	209D[3:0]	0	0	R/W	The number of states in the input multiplexer.										
<i>MUX_SYNC_E</i>	2020[7]	0	0	R/W	When set, SEG7 outputs <i>MUX_SYNC</i> . Otherwise, SEG7 is an LCD pin.										
<i>OPT_FDC[1:0]</i>	2007[1:0]	0	0	R/W	Selects the modulation duty cycle for <i>OPT_TX</i> . <table border="1"> <thead> <tr> <th><i>OPT_FDC[1:0]</i></th> <th>Function</th> </tr> </thead> <tbody> <tr> <td>00</td> <td>50% Low</td> </tr> <tr> <td>01</td> <td>25% Low</td> </tr> <tr> <td>10</td> <td>12.5% Low</td> </tr> <tr> <td>11</td> <td>6.25% Low</td> </tr> </tbody> </table>	<i>OPT_FDC[1:0]</i>	Function	00	50% Low	01	25% Low	10	12.5% Low	11	6.25% Low
<i>OPT_FDC[1:0]</i>	Function														
00	50% Low														
01	25% Low														
10	12.5% Low														
11	6.25% Low														
<i>OPT_RXDIS</i>	2008[5]	0	0	R/W	Configures <i>OPT_RX</i> to an analog input to the optical UART comparator or as a digital input/output, DIO1: 0 = <i>OPT_RX</i> , 1 = DIO1.										
<i>OPT_RXINV</i>	2008[4]	0	0	R/W	Inverts the result from the <i>OPT_RX</i> comparator when 1. Affects only the UART input. Has no effect when <i>OPT_RX</i> is used as a DIO input.										
<i>OPT_TXE[1:0]</i>	2007[7:6]	00	00	R/W	Configures the <i>OPT_TX</i> output pin. <table border="1"> <thead> <tr> <th><i>OPT_TXE[1:0]</i></th> <th>Function</th> </tr> </thead> <tbody> <tr> <td>00</td> <td><i>OPT_TX</i></td> </tr> <tr> <td>01</td> <td>DIO2</td> </tr> <tr> <td>10</td> <td>WPULSE</td> </tr> <tr> <td>11</td> <td>RPULSE</td> </tr> </tbody> </table>	<i>OPT_TXE[1:0]</i>	Function	00	<i>OPT_TX</i>	01	DIO2	10	WPULSE	11	RPULSE
<i>OPT_TXE[1:0]</i>	Function														
00	<i>OPT_TX</i>														
01	DIO2														
10	WPULSE														
11	RPULSE														
<i>OPT_TXINV</i>	2008[0]	0	0	R/W	Inverts <i>OPT_TX</i> when 1. This inversion occurs before modulation.										
<i>OPT_TXMOD</i>	2008[1]	0	0	R/W	Enables modulation of <i>OPT_TX</i> . When <i>OPT_TXMOD</i> is set, <i>OPT_TX</i> is modulated when it would otherwise have been zero. The modulation is applied after any inversion caused by <i>OPT_TXINV</i> .										
<i>PLL_OK</i>	2003[6]	0	0	R	Indicates that system power is present and the clock generation PLL is settled.										
<i>PLS_MAXWIDTH</i> [7:0]	2080[7:0]	FF	FF	R/W	Determines the maximum width of the pulse (low going pulse). The maximum pulse width is $(2 * PLS_MAXWIDTH + 1) * T_1$. Where T_1 is <i>PLS_INTERVAL</i> . If <i>PLS_INTERVAL</i> = 0, T_1 is the sample time (397 μ s). If set to 255, pulse width control is disabled and pulses are output with a 50% duty cycle.										
<i>PLS_INTERVAL</i> [7:0]	2081[7:0]	0	0	R/W	For PULSE_W and PULSE_V only: If the FIFO is used, <i>PLS_INTERVAL</i> must be set to 81. If <i>PLS_INTERVAL</i> = 0, the FIFO is not used and pulses are output as soon as the CE issues them.										

Name	Location	Reset	Wake	Dir	Description										
<i>PLS_INV</i>	2004[6]	0	0	R/W	Inverts the polarity of the pulse outputs. Normally, these pulses are active low. When inverted, they become active high.										
<i>PREBOOT</i>	SFRB2[7]	–	–	R	Indicates that the preboot sequence is active.										
<i>PREG[16:0]</i>	201C[2:0] 201D[7:0] 201E[7:2]	4 0 0	NV NV NV	R/W R/W R/W	RTC adjust. See Section 1.5.3 Real-Time Clock (RTC) for additional details. 0x0FFBF ≤ <i>PREG</i> [16:0] ≤ 0x10040 <i>PREG</i> [16:0] and <i>QREG</i> [1:0] are separate in hardware but can be programmed with a single number calculated by the MPU. <i>PREG</i> [16:0] and <i>QREG</i> [1:0] are non-volatile, but have no correcting function in SLEEP mode.										
<i>PRE_SAMPS[1:0]</i>	2001[7:6]	0	0	R/W	The duration of the pre-summer, in samples. <table border="1" style="margin-left: 20px;"> <thead> <tr> <th><i>PRE_SAMPS</i>[1:0]</th> <th>Pre-summer Duration</th> </tr> </thead> <tbody> <tr> <td>00</td> <td>42</td> </tr> <tr> <td>01</td> <td>50</td> </tr> <tr> <td>10</td> <td>84</td> </tr> <tr> <td>11</td> <td>100</td> </tr> </tbody> </table>	<i>PRE_SAMPS</i> [1:0]	Pre-summer Duration	00	42	01	50	10	84	11	100
<i>PRE_SAMPS</i> [1:0]	Pre-summer Duration														
00	42														
01	50														
10	84														
11	100														
<i>QREG</i> [1:0]	201E[1:0]	0	0	R/W	RTC adjust. See Section 1.5.3 Real-Time Clock (RTC) for additional details.										
<i>RST_SUBSEC</i>	2010[0]	0	0	R/W	The sub-second counter is restarted when a 1 is written to this bit.										
<i>RTCA_ADJ</i> [6:0]	2011[6:0]	40	–	R/W	Analog RTC adjust. See Section 1.5.3 Real-Time Clock (RTC) for additional details.										
<i>RTC_SEC</i> [5:0] <i>RTC_MIN</i> [5:0] <i>RTC_HR</i> [4:0] <i>RTC_DAY</i> [2:0] <i>RTC_DATE</i> [4:0] <i>RTC_MO</i> [3:0] <i>RTC_YR</i> [7:0]	2015 2016 2017 2018 2019 201A 201B	* * * * * * *	NV NV NV NV NV NV NV	R/W	These are the year, month, day, hour, minute and second parameters of the RTC. Writing to these registers sets the time. Each write operation to one of these registers must be preceded by a write to 0x201F (<i>WE</i>). Valid values for each parameter are: SEC: 00 to 59, MIN: 00 to 59, HR: 00 to 23 (00 = Midnight) DAY: 01 to 07 (01 = Sunday), DATE: 01 to 31, MO: 01 to 12 YR: 00 to 99 (00 and all others divisible by 4 are leap years) Values in the RTC registers are undefined when the IC powers up without a battery but are maintained through mission and battery modes when a sufficient voltage is maintained at the VBAT pin. * no change of value at reset. See Application Note AN4947 for details on RTC.										
<i>RTM_E</i>	2002[3]	0	0	R/W	Real Time Monitor (RTM) enable. When 0, the RTM output is low.										
<i>RTM0</i> [9:0] <i>RTM1</i> [9:0] <i>RTM2</i> [9:0] <i>RTM3</i> [9:0]	2060[9:8] 2061[7:0] 2062[9:8] 2063[7:0] 2064[9:8] 2064[7:0] 2065[9:8] 2066[7:0]	0 0 0 0 0 0 0 0	0 0 0 0 0 0 0 0	R/W	The four RTM probes. Before each CE code pass, the values of these registers are serially output on the RTM pin. The RTM registers are ignored when <i>RTM_E</i> = 0.										

Name	Location	Reset	Wake	Dir	Description
<i>SECURE</i>	SFRB2[6]	0	–	R/W	When set, enables security provisions that prevent external reading of the flash memory (zeros will be returned if the flash is read). <i>SECURE</i> should be set during the preboot phase, i.e. while <i>PREBOOT</i> is set. <i>SECURE</i> is cleared when the flash is mass-erased and when the chip is reset. The bit may only be set, attempts to write zero are ignored.
<i>SEL_IAN</i>	20AC[1]	0	0	R/W	When set to 1, selects differential mode for the current input (IAP, IAN). When 0, the input remains single-ended (71M6532D/F only).
<i>SEL_IBN</i>	20AC[5]	0	0	R/W	When set to 1, selects differential mode for the current input (IBP, IBN). When 0, the input remains single-ended (71M6532D/F only).
<i>SLEEP</i>	20A9[6]	0	0	W	Puts the 71M6531 into SLEEP mode. This bit is ignored if system power is present. The 71M6531 will wake when the autowake timer times out, when the push button is pushed, when system power returns, or when RESET goes high.
<i>SLOT0_SEL</i> [3:0] <i>SLOT1_SEL</i> [3:0] <i>SLOT2_SEL</i> [3:0] <i>SLOT3_SEL</i> [3:0]	2090[3:0] 2090[7:4] 2091[3:0] 2091[7:4]	0 1 2 3	0 1 2 3	R/W	Primary multiplexer frame analog input selection. These bits map the selected input, 0-3 to the multiplexer state. The ADC output is always written to the memory location corresponding to the input, regardless of which multiplexer state an input is mapped to (see Section 1.2 Analog Front End (AFE)).
<i>SLOT0_ALTSEL</i> [3:0] <i>SLOT1_ALTSEL</i> [3:0] <i>SLOT2_ALTSEL</i> [3:0] <i>SLOT3_ALTSEL</i> [3:0]	2096[3:0] 2096[7:4] 2097[3:0] 2097[7:4]	A 1 2 3	A 1 B 3	R/W	Alternate multiplexer frame analog input selection. Maps the selected input to the multiplexer state. The additional inputs, 10 and 11 in the alternate frame are: 10 = TEMP 11 = VBAT
<i>SP_ADDR</i> [15:8] <i>SP_ADDR</i> [7:0]	2072[7:0] 2073[7:0]	0 0	0 0	R R	SPI Address. 16-bit address from the bus master.
<i>SP_CMD</i>	2071	0	0	R	SPI command. 8-bit command from the bus master.
<i>SPE</i>	2070[7]	0	0	R/W	SPI port enable. Enables the SPI interface on pins SEG3 through SEG5.
<i>SPI_FLAG</i>	20B1[4]	1	1	R/W	SPI interrupt flag. The flag is set by the hardware and is cleared by the firmware writing a 0. Firmware using this interrupt should clear the spurious interrupt indication during initialization.
<i>SUBSEC</i> [7:0]	2014[7:0]	–	–	R	The remaining count, in terms of 1/256 RTC cycles, to the next one second boundary. <i>SUBSEC</i> may be read by the MPU after the one second interrupt and before reaching the next one second boundary. Setting <i>RST_SUBSEC</i> will clear <i>SUBSEC</i> .
<i>SUM_CYCLES</i> [5:0]	2001[5:0]	0	0	R/W	The number of pre-summer outputs summed in the final summing stage of the CE.
<i>TMUX</i> [4:0]	20AA[4:0]	2	–	R/W	Selects one of 32 signals for TMUXOUT. For details, see Section 1.5.17 Test Ports (TMUXOUT pin).
<i>TRIM</i> [7:0]	20FF	0	0	R/W	Contains fuse information, depending on the value written to <i>TRIMSEL</i> [3:0].

Name	Location	Reset	Wake	Dir	Description						
<i>TRIMSEL</i> [3:0]	20FD[3:0]	0	0	R/W	Selects the trim fuse to be read with the <i>TRIM</i> register: <table border="1"> <thead> <tr> <th><i>TRIMSEL</i>[3:0]</th> <th>Trim Fuse</th> <th>Purpose</th> </tr> </thead> <tbody> <tr> <td>1</td> <td><i>TRIMT</i>[7:0]</td> <td>Trim for the magnitude of VREF</td> </tr> </tbody> </table>	<i>TRIMSEL</i> [3:0]	Trim Fuse	Purpose	1	<i>TRIMT</i> [7:0]	Trim for the magnitude of VREF
<i>TRIMSEL</i> [3:0]	Trim Fuse	Purpose									
1	<i>TRIMT</i> [7:0]	Trim for the magnitude of VREF									
<i>VERSION</i> [7:0]	2006 20C8	– –	– –	R R	The device version index. This word may be read by the firmware to determine the silicon version. <table border="1"> <thead> <tr> <th><i>VERSION</i>[7:0]</th> <th>Silicon Version</th> </tr> </thead> <tbody> <tr> <td>0001 0101</td> <td>A05</td> </tr> </tbody> </table>	<i>VERSION</i> [7:0]	Silicon Version	0001 0101	A05		
<i>VERSION</i> [7:0]	Silicon Version										
0001 0101	A05										
<i>VREF_CAL</i>	2004[7]	0	0	R/W	Brings VREF to the VREF pad. This feature is disabled when <i>VREF_DIS</i> = 1.						
<i>VREF_DIS</i>	2004[3]	0	0	R/W	Disables the internal voltage reference.						
<i>WAKE_ARM</i>	20A9[7]	0	–	W	Arm the autowake timer. Writing a 1 to this bit arms the autowake timer and presets it with the values presently in <i>WAKE_PRD</i> and <i>WAKE_RES</i> . The autowake timer is reset and disarmed whenever the IC is in MISSION or BROWNOUT mode. The timer must be armed at least three RTC cycles before the SLEEP or LCD-ONLY mode is commanded.						
<i>WAKE_PRD</i>	20A9[2:0]	001	–	R/W	Sleep time. Time = <i>WAKE_PRD</i> [2:0]* <i>WAKE_RES</i> . Default = 001. Maximum value is 7.						
<i>WAKE_RES</i>	20A9[3]	0	–	R/W	Resolution of WAKE timer: 1 = 1 minute, 0 = 2.5 seconds.						
<i>WD_NROVF_FLAG</i>	20B1[0]	–	0	R/W	This flag is set approximately 1 ms before the watchdog timer overflows. It is cleared by writing a 0 or on the falling edge of WAKE.						
<i>WD_RST</i>	SFR F8[7]	0	0	W	WD timer bit. This bit <u>must</u> be accessed with byte operations. Operations possible for this bit are: Write 0xFF: Resets the WDT.						
<i>WD_OVF</i>	2002[2]	0	0	R/W	The WD overflow status bit. This bit is set when the WD timer overflows. It is powered by the nonvolatile supply and at bootup will indicate if the part is recovering from a WD overflow or a power fault. This bit should be cleared by the MPU on bootup. It is also automatically cleared when RESET is high. *Not preserved in SLEEP mode						
<i>WE</i>	201F[7:0]	–	–	W	An 8-bit value has to be written to this address prior to accessing the RTC registers.						
<i>WRPROT_BT</i>	SFR B2[5]	0	0		When set, this bit protects flash addresses from 0 to <i>BOOT_SIZE</i> *1024 from flash page erase.						
<i>WRPROT_CE</i>	SFR B2[4]	0	0		When set, this bit protects flash addresses from <i>CE_LCTN</i> *1024 to the end of memory from flash page erase.						

4.3 CE Interface Description

4.3.1 CE Program

The CE performs the precision computations necessary to accurately measure energy. Different code variations are used for $EQU[2:0] = 0$ and $EQU[2:0] = 1$ or 2 . The computations include offset cancellation, products, product smoothing, product summation, frequency detection, VAR calculation, sag detection, peak detection and voltage phase measurement. All data computed by the CE is dependent on the selected meter equation as given by $EQU[2:0]$. Although $EQU[2:0] = 0$ and $EQU[2:0] = 2$ have the same element mapping, the MPU code can use the value of $EQU[2:0]$ to decide if element 2 is used for tamper detection (typically done by connecting VB to VA) or as a second independent element.

The CE program is supplied by Maxim as a data image that can be merged with the MPU operational code for meter applications. Typically, the CE program covers most applications and does not need to be modified. Other variations of CE code may be available from Maxim. The description in this section applies to CE code revision CE31A04 (for $EQU[2:0] = 0$). Deviations for code revision CE31A03 (for $EQU[2:0] = 1$ or 2) are noted where applicable.

4.3.2 CE Data Format

All CE words are 4 bytes. Unless specified otherwise, they are in 32-bit two's complement format ($-1 = 0xFFFFFFFF$). Calibration parameters are defined in flash memory (or external EEPROM) and must be copied to CE data memory by the MPU before enabling the CE. Internal variables are used in internal CE calculations. Input variables allow the MPU to control the behavior of the CE code. Output variables are outputs of the CE calculations. The corresponding MPU address for the most significant byte is given by $0x0000 + 4 \times CE_address$ and by $0x0003 + 4 \times CE_address$ for the least significant byte.

4.3.3 Constants

Constants used in the CE Data Memory tables are:

- $F_S = 32768 \text{ Hz}/13 = 2520.62 \text{ Hz}$.
- F_0 is the fundamental frequency.
- IMAX is the external rms current corresponding to 250 mV pk at the inputs IA and IB.
- VMAX is the external rms voltage corresponding to 250 mV pk at the VA and VB inputs.
- NACC, the accumulation count for energy measurements is $PRE_SAMPS[1:0] \times SUM_CYCLES[5:0]$.
- The duration of the accumulation interval for energy measurements is $PRE_SAMPS[1:0] \times SUM_CYCLES[5:0] / F_S$.
- In_8 is a gain constant of the current channel, n. Its value is 8 or 1 and is controlled by In_SHUNT .
- X is a gain constant of the pulse generators. Its value is determined by $PULSE_FAST$ and $PULSE_SLOW$.
- Voltage LSB for sag detection = $VMAX \times 7.8798 \times 10^{-6} \text{ V}$.

The system constants IMAX and VMAX are used by the MPU to convert internal quantities (as used by the CE) to external, i.e. metering quantities. Their values are determined by the off-chip scaling of the voltage and current sensors used in an actual meter. The LSB values used in this document relate digital quantities at the CE or MPU interface to external meter input quantities. For example, if a SAG threshold of 80 V peak is desired at the meter input, the digital value that should be programmed into SAG_THR would be $80/SAG_THR_{LSB}$, where SAG_THR_{LSB} is the LSB value in the description of SAG_THR .

The parameters $EQU[2:0]$, CE_E , $PRE_SAMPS[1:0]$ and $SUM_CYCLES[5:0]$ essential to the function of the CE are stored in I/O RAM (see Section 4.2 I/O RAM Description – Alphabetical Order).

4.3.4 Environment

Before starting the CE using the CE_E bit, the MPU has to establish the proper environment for the CE by implementing the following steps (for CE31A04 code):

- Load the CE data into RAM.
- Establish the equation to be applied in $EQU[2:0]$. The CE code has to match the selected equation.
- Establish the accumulation period and number of samples in $PRE_SAMPS[1:0] = 0$ (multiplier = 42) and $SUM_CYCLES[5:0] = 0x3C$ (60).
- Set $PLS_INTERVAL[7:0]$ to 81.
- Select the values for $FIR_LEN[1:0] = 2$ and $MUX_DIV[3:0] = 4$.

- Select the values for $SLOT0_SEL[3:0] = 0$, $SLOT1_SEL[3:0] = 1$, $SLOT2_SEL[3:0] = 2$, $SLOT3_SEL[3:0] = 3$
- Select the values for $SLOT0_ALTSEL[3:0] = 0x0A$, $SLOT1_ALTSEL[3:0] = 1$, $SLOT2_ALTSEL[3:0] = 0x0B$, $SLOT3_ALTSEL[3:0] = 3$.
- Set $CHOP_E[1:0] = 00$.
- Initialize any MPU interrupts, such as CE_BUSY , $XFER_BUSY$, or a power failure detection interrupt.

When different CE codes are used, a different set of environment parameters needs to be established. The exact values for these parameters are stated in the Application Notes and other documentation accompanying the CE codes.



CE codes should only be used with environment parameters specified in this document or in the applicable CE code description. Changing environment parameters at random will lead to unpredictable results.

Typically, there are thirteen 32768 Hz cycles per ADC multiplexer frame (see [Figure 19](#)). This means that the product of the number of cycles per frame and the number of conversions per frame must be 12 (allowing for one settling cycle).

During operation, $CHOP_E[1:0] = 00$ enables the automatic chopping mode and forces an alternate multiplexer sequence at regular intervals. This enables accurate temperature measurement.

4.3.5 CE Calculations

Table 56: CE EQU[2:0] Equations and Element Input Mapping

EQU[2:0]	Watt & VAR Formula (WSUM/VARSUM)	Element Input Mapping			
		W0SUM/ VAR0SUM	W1SUM/ VAR1SUM	I0SQSUM	I1SQSUM
0	VA IA (1 element, 2W 1 ϕ) with tamper detection	VA*IA	VA*IB	IA	IB
1	VA*(IA-IB)/2 (1 element, 3W 1 ϕ)	VA*(IA-IB)/2	(VA * IB)/2	IA-IB	IB
2	VA*IA + VB*IB (2 element, 4W 2 ϕ)	VA*IA	VB*IB	IA	IB

4.3.6 CE Status and Control

The *CESTATUS* register provides information about the status of voltage and input AC signal frequency, which are useful for generating early power fail warnings, e.g. to initiate necessary data storage. It contains sag warning flags for VA and VB as well as F_0 , the derived clock operating at the fundamental input frequency. *CESTATUS* represents the status flags for the preceding CE code pass (CE busy interrupt). Sag alarms are not remembered from one code pass to the next. The CE Status word is refreshed at every CE_BUSY interrupt. The significance of the bits in *CESTATUS* is shown in [Table 57](#).

CE Address	Name	Description
0x80	<i>CESTATUS</i>	See description of <i>CESTATUS</i> bits in Table 57 .

Since the CE_BUSY interrupt typically occurs at 2520.6 Hz, it is desirable to minimize the computation required in the interrupt handler of the MPU. Rather than reading the CE status word at every CE_BUSY interrupt and interpret the sag bits, it is recommended that the MPU activate the YPULSE output to generate interrupts when a sag occurs (see the description of the *CECONFIG* register)

Table 57: CESTATUS (CE RAM 0x80) Bit Definitions

CESTATUS [bit]	Name	Description
31:29	Not Used	These unused bits will always be zero.
28	<i>F0</i>	<i>F0</i> is a square wave at the exact fundamental frequency for the phase selected with the <i>FREQSELn</i> bits in <i>CECONFIG</i> .
27	Reserved	
26	<i>SAG_B</i>	Normally zero. Becomes one when VB remains below <i>SAG_THR</i> for <i>SAG_CNT</i> samples. Will not return to zero until VB rises above <i>SAG_THR</i> .
25	<i>SAG_A</i>	Normally zero. Becomes one when VA remains below <i>SAG_THR</i> for <i>SAG_CNT</i> samples. Will not return to zero until VA rises above <i>SAG_THR</i> .
24:0	Not Used	These unused bits will always be zero.

The CE is initialized and its functions are controlled by the MPU using *CECONFIG*. This register contains in packed form *SAG_CNT*, *FREQSEL*, *EXT_PULSE*, *I0_SHUNT*, *I1_SHUNT*, *PULSE_SLOW* and *PULSE_FAST*. The *CECONFIG* bit definitions are given in Table 58.

CE Address	Name	Data	Description
0x20	<i>CECONFIG</i>	0x5020	See description of the <i>CECONFIG</i> bits in Table 58.

IA_SHUNT and/or *IB_SHUNT* can configure their respective current inputs to accept shunt resistor sensors. In this case the CE provides an additional gain of 8 to the selected current input. *WRATE* may need to be adjusted based on the values of *IA_SHUNT* and *IB_SHUNT*. Whenever *IA_SHUNT* or *IB_SHUNT* are set to 1, *In_8* (in the equation for *Kh*) is assigned a value of 8.

The CE pulse generator can be controlled by either the MPU (external) or CE (internal) variables. Control is by the MPU if *EXT_PULSE* = 1. In this case, the MPU controls the pulse rate by placing values into *APULSEW*, *APULSER*, *APULSE2* and *APULSE3*. By setting *EXT_PULSE* = 0, the CE controls the pulse rate based on *WOSUM_X* and *VAROSUM_X* (*EQU[2:0]* = 0) or *WSUM_X* (*EQU[2:0]* = 2).

If *EXT_PULSE* = 0 and *EQU[2:0]* = 2, the pulse inputs are *WOSUM_X* + *WISUM_X* and *VAROSUM_X* + *VARISUM_X*. In this case, creep cannot be controlled since creep is an MPU function.

If *EXT_PULSE* = 0 and *EQU[2:0]* = 0, the pulse inputs are *WOSUM_X* if *I0SQSUM_X* > *I1SQSUM_X* and *WISUM_X*, if *I1SQSUM_X* > *I0SQSUM_X*.

- The 71M6531 Demo Code creep function halts both internal and external pulse generation.

The *EXT_TEMP* bit controls the temperature compensation mode:

- When *EXT_TEMP* = 0 (internal compensation), the CE will control the gain using *GAIN_ADJ* (see Table 60) based on *PPMC*, *PPMC2* and *TEMP_X*, the difference between die temperature and the reference / calibration temperature *TEMP_NOM*. Since *PPMC* and *PPMC2* reflect the typical behavior of the reference voltage over temperature, the internal temperature compensation eliminates the effects of temperature-related errors of *VREF* only.
- When *EXT_TEMP* = 1 (external compensation), the MPU is allowed to control the CE gain using *GAIN_ADJ*, based on any algorithm implemented in MPU code.

The *FREQSEL1* and *FREQSEL0* bits select the phase used to control the CE-internal PLL. CE accuracy depends on the channel selected by the *FREQSEL1* and *FREQSEL0* bits receiving a clean voltage signal.

Table 58: CECONFIG Bit Definitions

<i>CECONFIG</i> [bit]	Name	Default	Description																
[19]	<i>SAG_MASK1</i>	0	Sets the sag control of phase B.																
[18]	<i>SAG_MASK0</i>	0	Sets the sag control of phase A. If more than one sag mask is set, a sag interrupt will only be generated when all phases enabled for the interrupt sag.																
[17]	<i>SAG_INT</i>	0	When set, enables the sag interrupt to be output on the YPULSE/DIO9 pin.																
[16]	<i>EXT_TEMP</i>	0	When set, enables the control of <i>GAIN_ADJ</i> by the MPU. When 0, enables the control of <i>GAIN_ADJ</i> by the CE.																
[15:8]	<i>SAG_CNT</i>	80 (0x50)	The number of consecutive voltage samples below <i>SAG_THR</i> before a sag alarm is declared. The maximum value is 255. <i>SAG_THR</i> is at address 0x24.																
[7]	<i>FREQSEL1</i>	0	The combination of <i>FREQSEL1</i> and <i>FREQSEL0</i> selects the phase to be used for the frequency monitor, the phase-to-phase lag calculation, the zero-crossing counter <i>MAINEDGE_X</i> and the <i>F0</i> bit (<i>CESTATUS[28]</i>). <i>FREQSEL1</i> / <i>FREQSEL0</i> = 0/0: Phase A <i>FREQSEL1</i> / <i>FREQSEL0</i> = 0/1: Phase B																
[6]	<i>FREQSEL0</i>	0																	
[5]	<i>EXT_PULSE</i>	1	When zero, causes the pulse generators to respond to internal data (<i>PULSE0</i> = <i>WSUM_X</i> , <i>PULSE1</i> = <i>VARSUM_X</i> ., <i>PULSE2</i> = <i>VASUM_X</i>). Otherwise, the generators respond to values the MPU places in <i>APULSEW</i> and <i>APULSER</i> .																
[4]	–	0	Unused.																
[3]	<i>IB_SHUNT</i>	0	When 1, the current gain of channel B is increased by 8. The gain factor controlled by <i>In_SHUNT</i> is referred to as <i>In_8</i> throughout this document.																
[2]	<i>IA_SHUNT</i>	0	When 1, the current gain of channel A is increased by 8.																
[1]	<i>PULSE_FAST</i>	0	When <i>PULSE_FAST</i> = 1, the pulse generator input is increased 16x. When <i>PULSE_SLOW</i> = 1, the pulse generator input is reduced by a factor of 64. These two bits control the pulse gain factor X (see table below). Default is 0 for both (X = 6).																
[0]	<i>PULSE_SLOW</i>	0		<table border="1"> <thead> <tr> <th><i>PULSE_SLOW</i></th> <th><i>PULSE_FAST</i></th> <th>X</th> </tr> </thead> <tbody> <tr> <td>0</td> <td>0</td> <td>$1.5 * 2^2 = 6$</td> </tr> <tr> <td>0</td> <td>1</td> <td>$1.5 * 2^6 = 96$</td> </tr> <tr> <td>1</td> <td>0</td> <td>$1.5 * 2^{-4} = 0.09375$</td> </tr> <tr> <td>1</td> <td>1</td> <td>Do not use</td> </tr> </tbody> </table>	<i>PULSE_SLOW</i>	<i>PULSE_FAST</i>	X	0	0	$1.5 * 2^2 = 6$	0	1	$1.5 * 2^6 = 96$	1	0	$1.5 * 2^{-4} = 0.09375$	1	1	Do not use
				<i>PULSE_SLOW</i>	<i>PULSE_FAST</i>	X													
				0	0	$1.5 * 2^2 = 6$													
				0	1	$1.5 * 2^6 = 96$													
1	0	$1.5 * 2^{-4} = 0.09375$																	
1	1	Do not use																	
0	1	$1.5 * 2^6 = 96$																	
1	0	$1.5 * 2^{-4} = 0.09375$																	
1	1	Do not use																	

Table 59: Sag Threshold Control

CE Address	Name	Default	Description
0x24	<i>SAG_THR</i>	443000	The threshold for sag warnings. The default value is equivalent to 80 V RMS if <i>VMAX</i> = 600 V. The LSB value is <i>VMAX</i> * 4.255*10 ⁻⁷ V (peak).

Table 60: Gain Adjust Control

CE Address	Name	Default	Description
0x40	<i>GAIN_ADJ</i>	16384	This register scales all voltage and current channels. The default value is equivalent unity gain (1.000).

4.3.7 CE Transfer Variables

When the MPU receives the XFER_BUSY interrupt, it knows that fresh data is available in the transfer variables. CE transfer variables are modified during the CE code pass that ends with an XFER_BUSY interrupt. They remain constant throughout each accumulation interval. In this data sheet, the names of CE transfer variables always end with *_X*.

The transfer variables can be categorized as:

1. Fundamental energy measurement variables
2. Instantaneous (RMS) values
3. Other measurement parameters

Fundamental Energy Measurement Variables

Table 61 describes each transfer variable for fundamental energy measurement. All variables are signed 32-bit integers. Accumulated variables such as WSUM are internally scaled so they have at least 2x margin before overflow when the integration time is one second. Additionally, the hardware will not permit output values to fold back upon overflow.

Table 61: CE Transfer Variables

CE Address	Name	Description
0x85	<i>WSUM_X</i>	For <i>EQU[2:0] = 2</i> , this register holds the calculated sum of Wh samples from each wattmeter element (<i>In_8</i> is the gain of 1 or 8 configured by <i>IA_SHUNT</i> or <i>IB_SHUNT</i>). LSB = $6.6952 \cdot 10^{-13} \text{ VMAX IMAX} / In_8 \text{ Wh}$.
0x86	<i>WOSUM_X</i>	The sum of Wh samples from each wattmeter element (<i>In_8</i> is the gain of 1 or 8 configured by <i>IA_SHUNT</i> or <i>IB_SHUNT</i>). LSB = $6.6952 \cdot 10^{-13} \text{ VMAX IMAX} / In_8 \text{ Wh}$.
0x87	<i>WISUM_X</i>	
0x8A	<i>VARSUM_X</i>	For <i>EQU[2:0] = 2</i> , this register holds the calculated sum of VARh samples from each element (<i>In_8</i> is the gain of 1 or 8 configured by <i>IA_SHUNT</i> or <i>IB_SHUNT</i>). LSB = $6.6952 \cdot 10^{-13} \text{ VMAX IMAX} / In_8 \text{ VARh}$.
0x8B	<i>VAROSUM_X</i>	The sum of VARh samples from each element (<i>In_8</i> is the gain 1 or 8 configured by <i>IA_SHUNT</i> or <i>IB_SHUNT</i>). LSB = $6.6952 \cdot 10^{-13} \text{ VMAX IMAX} / In_8 \text{ VARh}$.
0x8C	<i>VARISUM_X</i>	

WxSUM_X is the Wh value accumulated for element X in the last accumulation interval and can be computed based on the specified LSB value.

For example, with VMAX = 600 V and IMAX = 208 A, the LSB for *WxSUM_X* is 0.08356 μWh.

Instantaneous Measurement Variables

Table 62 contains various measurement results. The Frequency measurement is computed for the phase selected with *FREQSELn* bits in the *CECONFIG* register.

IxSQSUM_X and *VxSQSUM_X* are the squared current and voltage samples acquired during the last accumulation interval. They can be used to calculate RMS voltages and currents. *INSQSUM_X* can be used for computing the neutral current.

Table 62: CE Energy Measurement Variables

CE Address	Name	Description
0x82	<i>FREQ_X</i>	Fundamental frequency. LSB = $\frac{F_s}{2^{32}} \approx 0.587 \cdot 10^{-6} \text{ Hz}$
0x8F	<i>I0SQSUM_X</i>	The sum of squared current samples from each element.

0x90	<i>IISQSUM_X</i>	$LSB_I = 6.6952 \cdot 10^{-13} \text{ IMAX}^2 / \text{In}_8^2 \text{ A}^2\text{h}$
0x93	<i>VOSQSUM_X</i>	The sum of squared voltage samples from each element. $LSB_V = 6.6952 \cdot 10^{-13} \text{ VMAX}^2 \text{ V}^2\text{h}$
0x94	<i>VISQSUM_X</i>	
0x45	<i>WSUM_ACCUM</i>	These registers contain roll-over accumulators for WPULSE and VPULSE respectively.
0x46	<i>VSUM_ACCUM</i>	
0x47	<i>SUM3_ACCUM</i>	These registers contain roll-over accumulators for pulse outputs XPULSE and YPULSE respectively.
0x48	<i>SUM4_ACCUM</i>	
0x99	<i>IOSQRES_X</i>	These registers hold residual current measurements with double-precision accuracy. The exact current ISQn is: $ISQn = \text{InSQSUM}_X + 2^{32} * \text{InSQRES}_X$
0x9A	<i>IISQRES_X</i>	

The RMS values can be computed by the MPU from the squared current and voltage samples as follows:

$$I_{x_{RMS}} = \sqrt{\frac{I_{xSQSUM} \cdot LSB_I \cdot 3600 \cdot F_s}{N_{ACC}}} \quad V_{x_{RMS}} = \sqrt{\frac{V_{xSQSUM} \cdot LSB_V \cdot 3600 \cdot F_s}{N_{ACC}}}$$

Other Measurement Parameters

Table 63 describes the CE measurement parameters listed below:

- *MAINEDGE_X*: Useful for implementing a real-time clock based on the input AC signal. *MAINEDGE_X* is the number of half-cycles accounted for in the last accumulated interval for the AC signal.
- *TEMP_RAW*: May be used by the MPU to monitor the chip temperature or to implement temperature compensation.
- *GAIN_ADJ*: A scaling factor for measurements based on the temperature. *GAIN_ADJ* can be controlled by the MPU for temperature compensation.
- *VBAT_SUM_X*: This result can be used to calculate the measured battery voltage (VBAT).

Table 63: Useful CE Measurement Parameters

CE Address	Name	Default	Description
0x83	<i>MAINEDGE_X</i>	N/A	The number of zero crossings of the voltage selected with <i>FREQSELn</i> in the previous accumulation interval. Zero crossings are either direction and are debounced.
0x81	<i>TEMP_RAW_X</i>	N/A	The filtered, un-scaled reading from the temperature sensor.
0x9D	<i>TEMP_X</i>	N/A	This register contains the difference between the die temperature and the reference/calibration temperature as established in the <i>TEMP_NOM</i> register, measured in 0.1°C.
0x40	<i>GAIN_ADJ</i>	16384	Scales all voltage and current inputs. A value of 16384 provides unity gain. This register is used by the CE or by the MPU to implement temperature compensation.
0x84	<i>VBAT_SUM_X</i>	N/A	Output of the battery measurement. This value is equivalent to twice the measured ADC value.

4.3.8 Pulse Generation

Table 64 describes the CE pulse generation parameters *WRATE*, *APULSEW*, *APULSER*, *APULSE2* and *APULSE3*.

WRATE controls the number of pulses that are generated per measured Wh and VARh quantities. The lower *WRATE* is the slower the pulse rate for measured energy quantity. The metering constant Kh is derived from *WRATE* as the amount of energy measured for each pulse. That is, if Kh = 1 Wh/pulse, a power applied to the meter of 120 V and 30 A (3,600 W) results in one pulse per second. If the load is 240 V at 150 A (36,000 W), ten pulses per second will be generated.

The maximum pulse rate is 7.5 kHz for *APULSEW* and *APULSER* and 1.2 kHz for *APULSE2* and *APULSE3*.

The maximum time jitter is 67 μ s and is independent of the number of pulses measured. Thus, if the pulse generator is monitored for one second, the peak jitter is 67 ppm. After 10 seconds, the peak jitter is 6.7 ppm.

The average jitter is always zero. If it is attempted to drive either pulse generator faster than its maximum rate, it will simply output at its maximum rate without exhibiting any rollover characteristics. The actual pulse rate, using *WSUM* as an example, is:

$$RATE = \frac{WRATE \cdot WSUM \cdot F_S \cdot X}{2^{46}} Hz,$$

where F_S = sampling frequency (2520.6 Hz) and X = Pulse speed factor (as defined in the *CECONFIG* register with the *PULSE_FAST* and *PULSE_SLOW* bits).

Table 64: CE Pulse Generation Parameters

CE Address	Name	Default	Description
0x21	<i>WRATE</i>	827	$Kh = VMAX \cdot IMAX \cdot 47.1132 / (In_8 \cdot WRATE \cdot N_{ACC} \cdot X)$ Wh/pulse. The default value results in a Kh of 1.0 Wh/pulse when 2520 samples are taken in each accumulation interval (and $VMAX=600$, $IMAX = 442$ [for 400 μ Ω shunt], $In_8 = 1$, $X = 6$). Maximum value = $2^{15} - 1$.
0x41	<i>APULSEW</i>	0	Watt pulse generator input (see <i>DIO_PW</i> bit). The output pulse rate is: $APULSEW \cdot F_S \cdot 2^{-32} \cdot WRATE \cdot X \cdot 2^{-14}$. This input is buffered and can be loaded during a computation interval. The change will take effect at the beginning of the next interval.
0x42	<i>APULSER</i>	0	VAR pulse generator input (see <i>DIO_PV</i> bit). The output pulse rate is: $APULSER \cdot F_S \cdot 2^{-32} \cdot WRATE \cdot X \cdot 2^{-14}$. This input is buffered and can be loaded during a computation interval. The change will take effect at the beginning of the next interval.
0x43	<i>APULSE2</i>	0	Third pulse generator input (see <i>DIO_PV</i> bit). The output pulse rate is: $APULSE2 \cdot F_S \cdot 2^{-32} \cdot WRATE \cdot X \cdot 2^{-14}$. This input is buffered and can be loaded during a computation interval. The change will take effect at the beginning of the next interval.
0x44	<i>APULSE3</i>	0	Fourth pulse generator input (see <i>DIO_PV</i> bit). The output pulse rate is: $APULSE3 \cdot F_S \cdot 2^{-32} \cdot WRATE \cdot X \cdot 2^{-14}$. This input is buffered and can be loaded during a computation interval. The change will take effect at the beginning of the next interval.
0x38	<i>PULSE WIDTH</i>	12	Register for pulse width control of <i>XPULSE</i> and <i>YPULSE</i> . The maximum pulse width is $(2 \cdot PULSEWIDTH + 1) \cdot (1/F_S)$. The default value will generate pulses of 10 ms width at $F_S = 2520.62$ Hz.

4.3.9 CE Calibration Parameters

Table 65 lists the parameters that are typically entered to effect calibration of meter accuracy.

Table 65: CE Calibration Parameters

CE Address	Name	Default	Description
0x10	<i>CAL_IA</i>	16384	These constants control the gain of their respective channels. The nominal value for each parameter is $2^{14} = 16384$. The gain of each channel is directly proportional to its gain constant. Thus, if the gain of the IA channel is 1% slow, <i>CAL_IA</i> should be scaled by $1/(1 - 0.01)$ and the resulting value is 16549.
0x11	<i>CAL_VA</i>	16384	
0x12	<i>CAL_IB</i>	16384	
0x13	<i>CAL_VB</i>	16384	
0x18	<i>PHADJ_A</i>	0	These two constants control the CT phase compensation. No compensation occurs when $PHADJ_X = 0$. As $PHADJ_X$ is increased, more compensation (lag) is introduced. Range: $\pm 2^{15} - 1$. If it is desired to delay the current by the angle Φ , the equations are:

CE Address	Name	Default	Description
0x19	<i>PHADJ_B</i>	0	$PHADJ_X = 2^{20} \frac{0.02229 \cdot TAN\Phi}{0.1487 - 0.0131 \cdot TAN\Phi} \text{ at 60Hz}$ $PHADJ_X = 2^{20} \frac{0.0155 \cdot TAN\Phi}{0.1241 - 0.009695 \cdot TAN\Phi} \text{ at 50Hz}$
0x1F	<i>TEMP_NOM</i>	0	This register contains the reference point for the temperature measurement. At calibration temperature, the value read at <i>TEMP_RAW_X</i> should be written to <i>TEMP_NOM</i> . The CE will calculate the chip temperature <i>TEMP_X</i> relative to the reference temperature.
0x39	<i>DEGSCALE</i>	9174	The scale factor for the temperature calculation. It is not necessary to use values other than the default value.

4.3.10 Other CE Parameters

Table 66 shows the CE parameters used for suppression of noise due to scaling and truncation effects. The table also includes the parameter which indicates the CE Code version.

Table 66: CE Parameters for Noise Suppression and Code Version

CE Address	Name	Default	Description
0x22	<i>KVAR</i>	6448	This is the scale factor for the VAR calculation. No value other than the default value should be applied.
0x26	<i>QUANT_A</i>	0	These parameters are added to the Watt calculation for element 0 and 1 to compensate for input noise and truncation. LSB = (VMAX*IMAX / <i>In_8</i>) * 7.4162*10 ⁻¹⁰ W
0x27	<i>QUANT_B</i>	0	
0x2A	<i>QUANT_VARA</i>	0	These parameters are added to the VAR calculation for element A and B to compensate for input noise and truncation. LSB = (VMAX*IMAX / <i>In_8</i>) * 7.4162*10 ⁻¹⁰ W
0x2B	<i>QUANT_VARB</i>	0	
0x2E	<i>QUANT_IA</i>	0	These parameters are added to compensate for input noise and truncation in their respective channels in the squaring calculations for I ² and V ² . LSB = VMAX ² *7.4162*10 ⁻¹⁰ V ² and LSB = (IMAX ² / <i>In_8</i> ²)*7.4162*10 ⁻¹⁰ A ²
0x2F	<i>QUANT_IB</i>	0	
0x35	0x63653331		Text strings holding the CE version information as supplied by the CE data associated with the CE code. For example, the words 0x63653331 and 0x61303463 form the text string "ce31a04c". These locations are overwritten in operation.
0x36	0x61303463		
0x37	0x00000000		

4.3.11 CE Flow Diagrams

Figure 41 through Figure 43 show the data flow through the CE in simplified form. Functions not shown include delay compensation, sample interpolation, scaling and processing of meter equations.

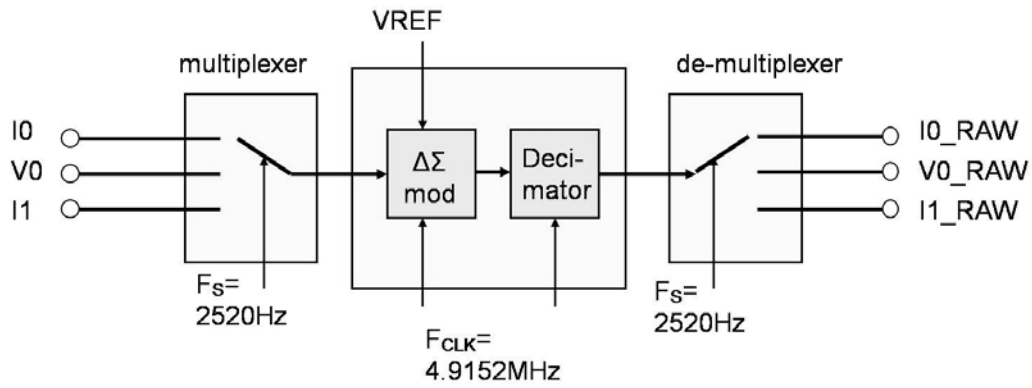

Figure 41: CE Data Flow: Multiplexer and ADC

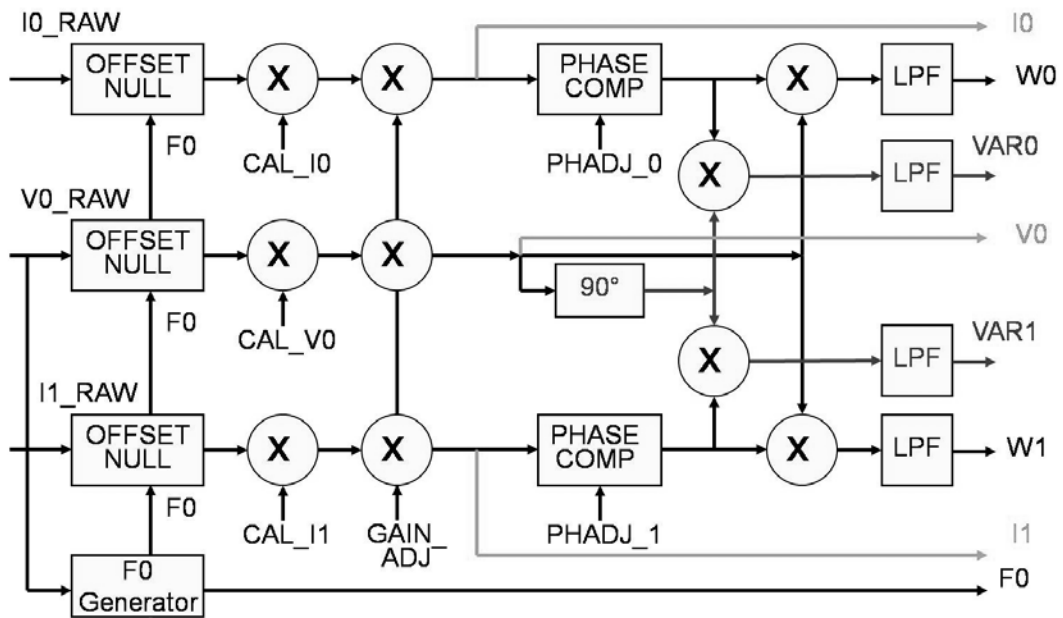

Figure 42: CE Data Flow: Scaling, Gain Control, Intermediate Variables

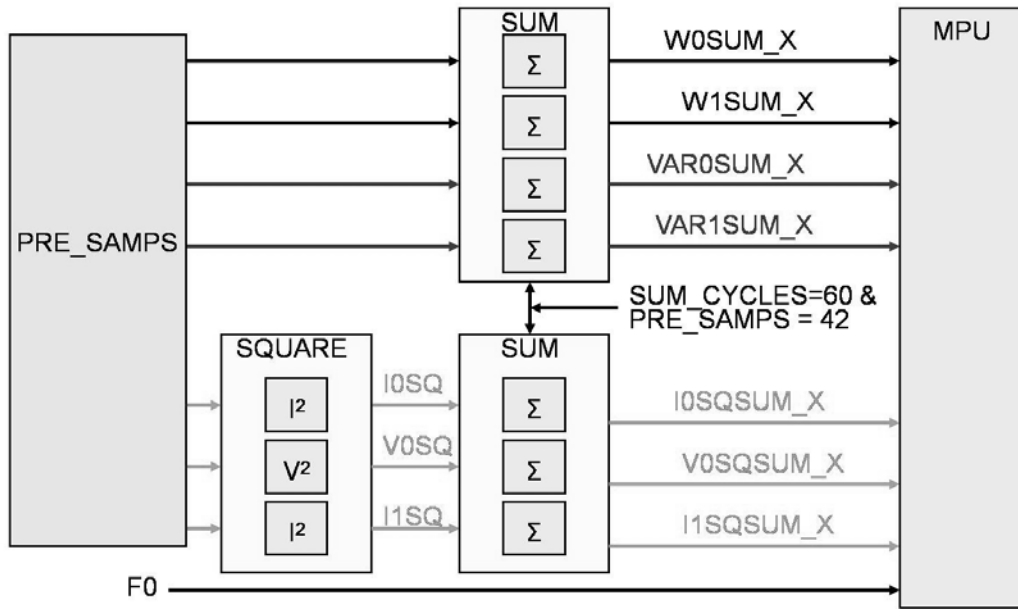

Figure 43: CE Data Flow: Squaring and Summation Stages

5 Electrical Specifications

5.1 Absolute Maximum Ratings

Table 67 shows the absolute maximum ranges for the device. Stresses beyond Absolute Maximum Ratings may cause permanent damage to the device. These are stress ratings only and functional operation at these or any other conditions beyond those indicated under recommended operating conditions (Section 5.3) is not implied. Exposure to absolute-maximum-rated conditions for extended periods may affect device reliability. All voltages are with respect to GNDA.

Table 67: Absolute Maximum Ratings

Voltage and Current	
Supplies and Ground Pins	
V3P3SYS, V3P3A	-0.5 V to 4.6 V
VBAT	-0.5 V to 4.6 V
GNDD	-0.5 V to +0.5 V
Analog Output Pins	
V3P3D	-10 mA to 10 mA, -0.5 V to 4.6 V
VREF	-10 mA to +10 mA, -0.5 V to V3P3A+0.5 V
V2P5	-10 mA to +10 mA, -0.5 V to 3.0 V
Analog Input Pins	
IA, VA, IB, VB, V1	-10 mA to +10 mA -0.5 V to V3P3A+0.5 V
XIN, XOUT	-10 mA to +10 mA -0.5 V to 3.0 V
All Other Pins	
Configured as SEG or COM drivers	-1 mA to +1 mA, -0.5 to V3P3D+0.5
Configured as Digital Inputs	-10 mA to +10 mA, -0.5 to 6 V
Configured as Digital Outputs	-15 mA to +15 mA, -0.5 V to V3P3D+0.5 V
All other pins	-0.5 V to V3P3D+0.5 V
Temperature and ESD Stress	
Operating junction temperature (peak, 100ms)	140 °C
Operating junction temperature (continuous)	125 °C
Storage temperature	-45 °C to +165 °C
Solder temperature – 10 second duration	250 °C
ESD stress on all pins	4 kV

5.2 Recommended External Components

Table 68: Recommended External Components

Name	From	To	Function	Value	Unit
C1	V3P3A	AGND	Bypass capacitor for 3.3 V supply	$\geq 0.1 \pm 20\%$ †	μF
C2	V3P3D	GNDD	Bypass capacitor for 3.3 V output	$0.1 \pm 20\%$ †	μF
CSYS	V3P3SYS	GNDD	Bypass capacitor for V3P3SYS	$\geq 1.0 \pm 30\%$	μF
C2P5	V2P5	GNDD	Bypass capacitor for V2P5	$0.1 \pm 20\%$	μF
XTAL	XIN	XOUT	32.768 kHz crystal – electrically similar to ECS .327-12.5-17X or Vishay XT26T, load capacitance 12.5 pF	32.768	kHz
CXS	XIN	AGND	Load capacitor for crystal (depends on crystal specs and board parasitics).	$33 \pm 10\%$	pF
CXL	XOUT	AGND	Load capacitor for crystal (depends on crystal specs and board parasitics).	$7 \pm 10\%$ ††	pF

Notes:

1. AGND and GNDD should be connected together.
2. V3P3SYS and V3P3A should be connected together.

† For accuracy and EMI rejection, C1 + C2 should be 470 μF or higher.

†† 10, 12, or 15 pF may be used if 7 pF is not available, with limited range for *RTCA_ADJ*.

5.3 Recommended Operating Conditions

Table 69: Recommended Operating Conditions

Parameter	Condition	Min	Typ	Max	Unit
V3P3SYS, V3P3A: 3.3 V Supply Voltage V3P3A and V3P3SYS must be at the same voltage	Normal Operation	3.0	3.3	3.6	V
	Battery Backup	0		3.6	V
VBAT	No Battery	Externally Connect to V3P3SYS			
	Battery Backup: BRN and LCD modes	3.0		3.8	V
	SLEEP mode	2.0		3.8	V
Operating Temperature		-40		+85	$^{\circ}\text{C}$

5.4 Performance Specifications

5.4.1 Input Logic Levels

Table 70: Input Logic Levels

Parameter	Condition	Min	Typ	Max	Unit
Digital high-level input voltage ^a , V _{IH}		2			V
Digital low-level input voltage ^a , V _{IL}				0.8	V
Input pull-up current, I _I L E_RXTX, E_RST, CKTEST Other digital inputs	V _{IN} =0 V, ICE_E=1	10 10 -1	0	100 100 1	μA μA μA
Input pull down current, I _I H ICE_E RESET PB Other digital inputs	V _{IN} = V3P3D	10 10 -1 -1	0 0	100 100 1 1	μA μA μA μA

^a In battery powered modes, digital inputs should be below 0.3 V or above 2.5 V to minimize battery current.

5.4.2 Output Logic Levels

Table 71: Output Logic Levels

Parameter	Condition	Min	Typ	Max	Unit
Digital high-level output voltage V _{OH}	I _{LOAD} = 1 mA	V3P3D-0.4			V
	I _{LOAD} = 15 mA	V3P3D-0.6			V
Digital low-level output voltage V _{OL}	I _{LOAD} = 1 mA	0		0.4	V
	I _{LOAD} = 15 mA			0.8	V
OPT_TX V _{OH} (V3P3D-OPT_TX)	I _{SOURCE} =1 mA			0.4	V
OPT_TX V _{OL}	I _{SINK} =20 mA			0.7	V

5.4.3 Power-Fault Comparator

Table 72: Power-Fault Comparator Performance Specifications

Parameter	Condition	Min	Typ	Max	Unit
Offset Voltage: V1-VBIAS		-20		+15	mV
Hysteresis Current: V1	V _{in} = VBIAS – 100 mV	0.8		1.2	μA
Response Time: V1	+100 mV overdrive Voltage at V1 rising		8	100	μs
	Voltage at V1 falling	10	37	100	μs
WDT Disable Threshold: V1-V3P3A		-400		-10	mV

5.4.4 Battery Monitor

Table 73: Battery Monitor Performance Specifications (BME= 1)

Parameter	Condition	Min	Typ	Max	Unit	
Load Resistor		27	45	63	kΩ	
LSB Value	[M40MHZ, M26MHZ] = [00], [10], or [11]	FIR_LEN[1:0]=0(L=138)	(-10%)	-48.7	(+10%)	μV
		FIR_LEN[1:0]=1(L=288)		-5.35		μV
		FIR_LEN[1:0]=2(L=384)		-2.26		μV
	[M40MHZ, M26MHZ] = [01]	FIR_LEN[1:0]=0(L=186)	(-10%)	-19.8	(+10%)	μV
		FIR_LEN[1:0]=1(L=384)		-2.26		μV
		FIR_LEN[1:0]=2(L=588)		-0.63		μV
Offset Error		-200	0	+100	mV	

5.4.5 Supply Current

Table 74: Supply Current Performance Specifications

Parameter	Condition	Min	Typ	Max	Unit
V3P3SYS current (CE off)	Normal Operation, V3P3A = V3P3SYS = 3.3 V CKMPU = 614 kHz		4.2	6.35	mA
V3P3SYS current (CE on)			8.4	9.6	mA
V3P3A current			3.3	3.8	mA
VBAT current	No Flash Memory write RTM_E=0, ECK_DIS=1, ADC_E=1, ICE_E=0	-400		+400	nA
V3P3SYS current, Write Flash	Normal Operation as above, except write Flash at maximum rate, CE_E = 0, ADC_E = 0		9.1	12	mA
VBAT current	VBAT=3.6V				
	BROWNOUT mode		52	250	μA
	71M6531D/F		82	250	μA
	71M6532D/F				
	LCD Mode				
	LCD DAC off		11	40	μA
	LCD DAC on		21	46	μA
	SLEEP Mode		0.7	1.5	μA

5.4.6 V3P3D Switch

Table 75: V3P3D Switch Performance Specifications

Parameter	Condition	Min	Typ	Max	Unit
On resistance – V3P3SYS to V3P3D	$ I_{V3P3D} \leq 1 \text{ mA}$		9	15	Ω
On resistance – VBAT to V3P3D	$ I_{V3P3D} \leq 1 \text{ mA}$		32	50	Ω

5.4.7 2.5 V Voltage Regulator

Table 76: 2.5 V Voltage Regulator Performance Specifications

Parameter	Condition	Min	Typ	Max	Unit
V2P5	Iload = 0	2.3	2.5	2.7	V
V2P5 load regulation	Iload = 0 mA to 5 mA			40	mV
Voltage overhead V3P3-V2P5	Iload = 5 mA, reduce V3P3 until V2P5 drops 200 mV			470	mV
PSSR $\Delta V2P5/\Delta V3P3$	RESET=0, Iload=0	-2		+2	mV/V

5.4.8 Low-Power Voltage Regulator

Unless otherwise specified, V3P3SYS = V3P3A = 0, PB=GND (BROWNOUT).

Table 77: Low-Power Voltage Regulator Performance Specifications

Parameter	Condition	Min	Typ	Max	Unit
V2P5	ILOAD = 0	2.3	2.5	2.7	V
V2P5 load regulation	ILOAD = 0 mA to 1 mA			30	mV
VBAT voltage requirement	ILOAD = 1 mA, reduce VBAT until REG_LP_OK = 0			3.0	V
PSRR $\Delta V2P5/\Delta VBAT$	ILOAD = 0	-50		50	mV/V

5.4.9 Crystal Oscillator

Table 78: Crystal Oscillator Performance Specifications

Parameter	Condition	Min	Typ	Max	Unit
Maximum Output Power to Crystal ⁴	Crystal connected			1	μW
XIN to XOUT Capacitance ¹				3	pF
Capacitance to GNDD ¹					
XIN	RTCA_ADJ[6:0] = 0			5	pF
XOUT				5	pF

5.4.10 LCD DAC

Table 79: LCD DAC Performance Specifications

Parameter	Condition	Min	Typ	Max	Unit
VLCD Voltage $V_{LCD} = V3P3 \cdot (1 - 0.059 \cdot LCD_DAC) - 0.019V$	$1 \leq LCD_DAC[2:0] \leq 7$	-10		+10	%

5.4.11 LCD Drivers

The information in [Table 80](#) applies to all COM and SEG pins with $LCD_DAC[2:0] = 000$.

Table 80: LCD Driver Performance Specifications

Parameter	Condition	Min	Typ	Max	Unit
VLC2 Voltage	With respect to VLCD ¹	-0.1		+0.1	V
VLC1 Voltage [†] , 1/3 bias	With respect to 2*VLC2/3	-3		+2	% VLC2
1/2 bias	With respect to VLC2/2	-3		+2	% VLC2
1/2 bias, minimum output level				1.0	V
VLC0 Voltage, 1/3 bias	With respect to VLC2/3	-4		+1	%
VLC1 Impedance	ΔLOAD = 100 μA (Isink)		9	15	kΩ
	ΔLOAD = -100 μA (Isource)		9	15	
VLC0 Impedance	ΔLOAD = 100 μA (Isink)		9	15	kΩ
	ΔLOAD = -100 μA (Isource)		9	15	

¹VLCD is V3P3SYS in MISSION mode and VBAT in BROWNOUT and LCD modes.

[†] Specified as percentage of VLC2, the maximum LCD voltage.

5.4.12 Optical Interface

Table 81: Optical Interface Performance Specifications

Parameter	Condition	Min	Typ	Max	Unit
OPT_TX VOH (V3P3D-OPT_TX)	ISOURCE = 1 mA			0.4	V
OPT_TX VOL	ISINK = 20 mA			0.7	V

5.4.13 Temperature Sensor

Table 82 shows the performance for the temperature sensor. The LSB values do not include the 8-bit left shift at CE input.

Table 82: Temperature Sensor Performance Specifications

Parameter	Condition	Min	Typ	Max	Unit
Nominal relationship: $N(T) = S_n \cdot (T - T_n) + N_n$, $T_n = 25^\circ\text{C}$					
Nominal Sensitivity (S_n) ² $S_n = -0.00109 \cdot \left(\frac{L}{3}\right)^3$	$[M40MHZ, M26MHZ] = [00], [10], \text{ or } [11]$	$FIR_LEN[1:0]=0$ (L=138) $FIR_LEN[1:0]=1$ (L=288) $FIR_LEN[1:0]=2$ (L=384)		-106 -964 -2286	LSB/°C
	$[M40MHZ, M26MHZ] = [01]$	$FIR_LEN[1:0]=0$ (L=186) $FIR_LEN[1:0]=1$ (L=384) $FIR_LEN[1:0]=2$ (L=588)		-260 -2286 -8207	
Nominal Offset (N_n) ² $N_n = 0.508 \cdot \left(\frac{L}{3}\right)^3$	$[M40MHZ, M26MHZ] = [00], [10], \text{ or } [11]$	$FIR_LEN[1:0]=0$ (L=138) $FIR_LEN[1:0]=1$ (L=288) $FIR_LEN[1:0]=2$ (L=384)		49447 449446 1065353	LSB
	$[M40MHZ, M26MHZ] = [01]$	$FIR_LEN[1:0]=0$ (L=186) $FIR_LEN[1:0]=1$ (L=384) $FIR_LEN[1:0]=2$ (L=588)		121071 1065353 3825004	
Temperature Error [†] $ERR = T - \left\{ \frac{(N(T) - N_n)}{S_n} \right\}$	$T_n = 25^\circ\text{C}$, $T = -40^\circ\text{C to } +85^\circ\text{C}$	-10 ¹		+10 ¹	°C

[†] Temperature error is calculated with the value N_n , which is measured at T_n during meter calibration and is stored in MPU or CE for use in temperature calculations.

¹ Guaranteed by design; not production tested.

² This specification defines a nominal relationship rather than a measured parameter. Correct circuit operation is to be verified with other specifications that use this nominal relationship as a reference.

5.4.14 VREF

Table 83 shows the performance specifications for VREF. Unless otherwise specified, $VREF_DIS = 0$.

Table 83: VREF Performance Specifications

Parameter	Condition	Min	Typ	Max	Unit
VREF output voltage, VREF(22)	$T_a = 22^\circ\text{C}$	1.193	1.195	1.197	V
VREF chop step				40	mV
VREF power supply sensitivity $\Delta VREF / \Delta V3P3A$	$V3P3A = 3.0 \text{ to } 3.6 \text{ V}$	-1.5		1.5	mV/V
VREF input impedance	$VREF_DIS = 1$, $VREF = 1.3 \text{ to } 1.7 \text{ V}$	100			kΩ

Parameter	Condition	Min	Typ	Max	Unit
VREF output impedance	CAL =1, ILOAD = 10 μ A, -10 μ A			2.5	k Ω
VNOM definition ^a	$VNOM(T) = VREF(22) + (T - 22)TC1 \cdot 10^{-6} + (T - 22)^2 TC2 \cdot 10^{-6}$				V
VNOM temperature coefficients: TC1 TC2		3.18 · (52.46 - TRIMT) -0.444			μ V/°C μ V/°C ²
VREF(T) deviation from VNOM(T) $\frac{VREF(T) - VNOM(T)}{VNOM(T)} \frac{10^6}{\max(T - 22 , 40)}$		-40 [†]		+40 [†]	PPM/°C
VREF aging			±25		PPM/ year

[†] Guaranteed by design; not production tested.

^a This relationship describes the nominal behavior of VREF at different temperatures.

5.4.15 ADC Converter, V3P3A Referenced

Table 84 shows the performance specifications for the ADC converter, V3P3A referenced. For this data, FIR_LEN[1:0]=0, VREF_DIS=0 and LSB values do not include the 8-bit left shift at the CE input.

Table 84: ADC Converter Performance Specifications

Parameter	Condition	Min	Typ	Max	Unit
Recommended Input Range (Vin-V3P3A)		-250		250	mV peak
Voltage to Current Crosstalk $\frac{10^6 * V_{crosstalk}}{V_{in}} \cos(\angle V_{in} - \angle V_{crosstalk})$	Vin = 200 mV peak, 65 Hz, on VA. Vcrosstalk = largest measurement on IA or IB	-10 [†]		10 [†]	μ V/V
THD (First 10 harmonics) ¹ : 250 mV-pk 20 mV-pk	Vin=65 Hz, 64 kpts FFT, Blackman- Harris window CKCE = 5 MHz			-75 -90	dB dB
Input Impedance	Vin = 65 Hz	40		90	k Ω
Temperature coefficient of Input Impedance	Vin = 65 Hz		1.7		Ω /°C
LSB size $V_{LSB} = V_{REF} \cdot \frac{1.25}{4.75} \cdot \left(\frac{3}{L}\right)^3$ L = FIR length	[M40MHZ, M26MHZ] = [00], [10], or [11]	FIR_LEN[1:0]=0 FIR_LEN[1:0]=1 FIR_LEN[1:0]=2		3231 355 150	nV/ LSB
	[M40MHZ, M26MHZ] = [01]	FIR_LEN[1:0]=0 FIR_LEN[1:0]=1 FIR_LEN[1:0]=2		1319 150 42	nV/ LSB
Digital Full Scale $\left(\frac{L}{3}\right)^3$ L = FIR length	[M40MHZ, M26MHZ] = [00], [10], or [11]	FIR_LEN[1:0]=0 FIR_LEN[1:0]=1 FIR_LEN[1:0]=2		±97336 ±884736 ±2097152	LSB
	[M40MHZ, M26MHZ] = [01]	FIR_LEN[1:0]=0 FIR_LEN[1:0]=1 FIR_LEN[1:0]=2		±238328 ±2097152 ±7529536	LSB

ADC Gain Error versus %Power Supply Variation $\frac{10^6 \Delta N_{out_{pk}} 357nV / V_{IN}}{100 \Delta V_{3P3A} / 3.3}$	Vin=200 mV pk, 65 Hz V3P3A=3.0 V, 3.6 V			50	ppm/%
Input Offset (Vin-V3P3A)		-10		10	mV

¹ Guaranteed by design; not production tested.

5.5 Timing Specifications

5.5.1 Flash Memory

Table 85: Flash Memory Timing Specifications

Parameter	Condition	Min	Typ	Max	Unit
Flash Read Pulse Width	V3P3A = V3P3SYS = 0 (BROWNOUT Mode)	30		100	ns
Flash write cycles	-40°C to +85°C	20,000			Cycles
Flash data retention	25°C	100			Years
Flash data retention	85°C	10			Years
Flash byte write operations between page or mass erase operations				2	Cycles
Write Time per Byte				42	µs
Page Erase (1024 bytes)				20	ms
Mass Erase				200	ms

5.5.2 EEPROM Interface

Table 86: EEPROM Interface Timing

Parameter	Condition	Min	Typ	Max	Unit
Write Clock frequency (I ² C)	CKMPU = 4.9 MHz, Using interrupts		78		kHz
	CKMPU = 4.9 MHz, bit-banging DIO4/5		150		kHz
Write Clock frequency (3-wire)	CKMPU=4.9 MHz		500		kHz

5.5.3 RESET

Table 87: RESET Timing

Parameter	Condition	Min	Typ	Max	Unit
Reset pulse width		5			µs
Reset pulse fall time				1 ¹	µs

¹ Guaranteed by design; not production tested.

5.5.4 RTC

Parameter	Condition	Min	Typ	Max	Unit
Range for date		2000		2255	year

5.5.5 SPI Slave Port (MISSION Mode)

Table 88: SPI Slave Port (MISSION Mode) Timing

Parameter	Condition	Min	Typ	Max	Unit
t_{SPICyc}	PCLK cycle time	1			μ S
$t_{SPILead}$	Enable lead time	15			ns
t_{SPILag}	Enable lag time	0			ns
t_{SPIW}	PCLK pulse width: High Low	40 40			ns ns
t_{SPISCK}	PCSZ to first PCLK fall	2			ns
t_{SPIDIS}	Disable time	0			ns
t_{SPIEV}	PCLK to Data Out			15	ns
t_{SPISU}	Data input setup time	10			ns
t_{SPIH}	Data input hold time	5			ns

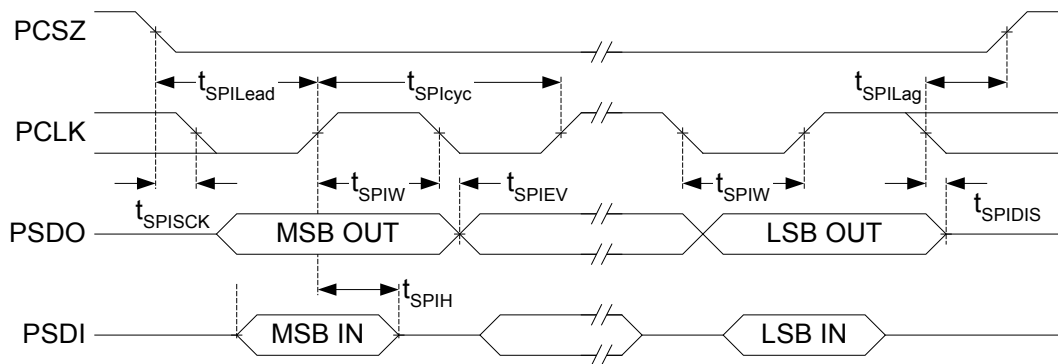

Figure 44: SPI Slave Port (MISSION Mode) Timing

Electrical Specification Footnotes

1. This spec will be guaranteed and verified in production samples, but will not be measured in production.
2. This spec will be guaranteed and verified in production samples, but will be measured in production only at DC.
3. This spec will be measured in production at the limits of the specified operating temperature.
4. This spec defines a nominal relationship rather than a measured parameter. Correct circuit operation will be verified with other specs that use this nominal relationship as a reference.

5.6 Typical Performance Data

5.6.1 Accuracy over Current

Figure 45 shows accuracy over current for various load angles at room temperature.

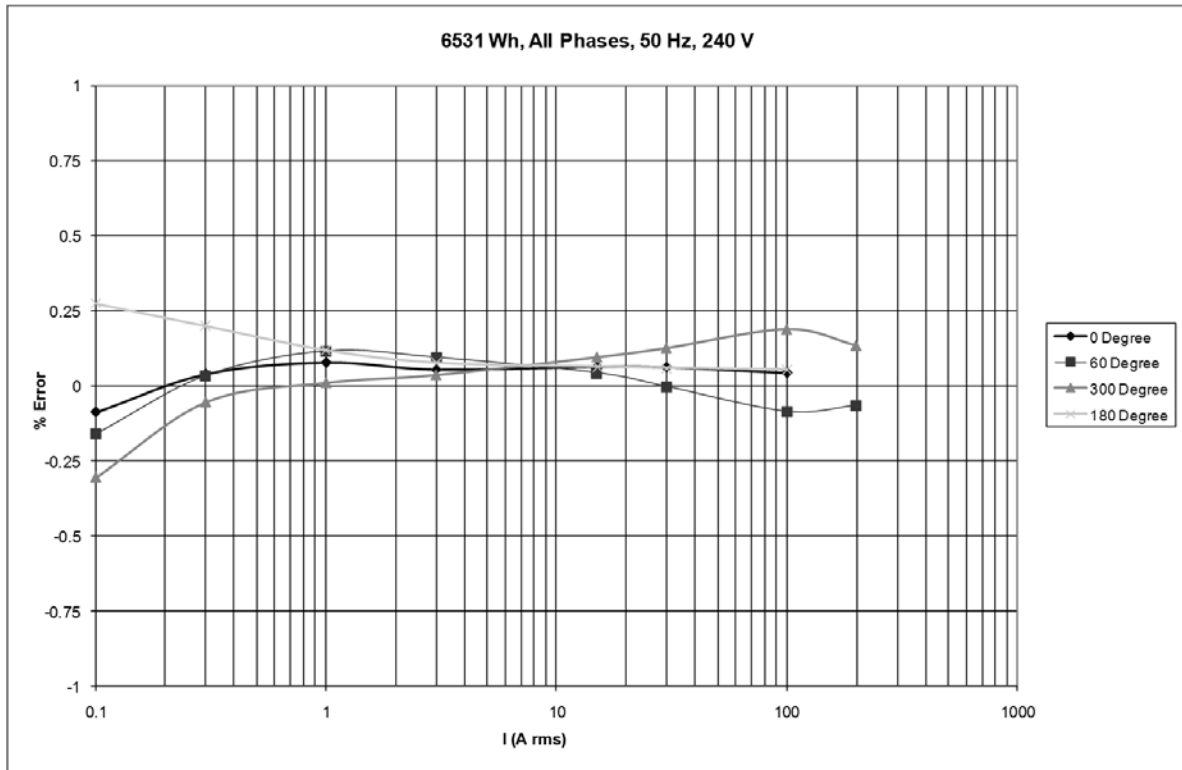

Figure 45: Wh Accuracy, 0.1 A to 200 A at 240 V/50 Hz and Room Temperature

5.6.2 Accuracy over Temperature

With digital temperature compensation enabled, the temperature characteristics of the reference voltage (VREF) are compensated to within ± 40 PPM/ $^{\circ}\text{C}$ (see section 3.4 for details).

5.7 71M6531D/F Package

5.7.1 Package Outline

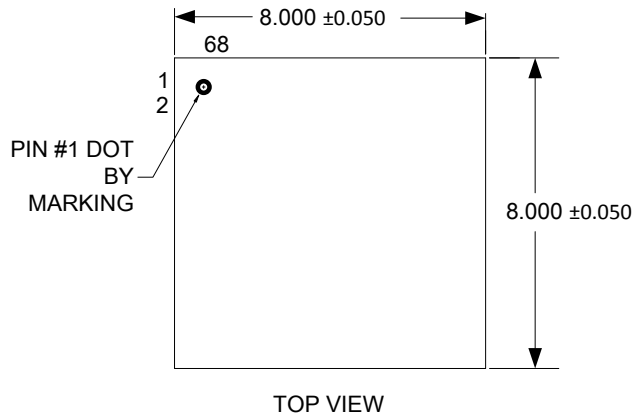

Figure 46: QFN-68 Package Outline, Top and Side View

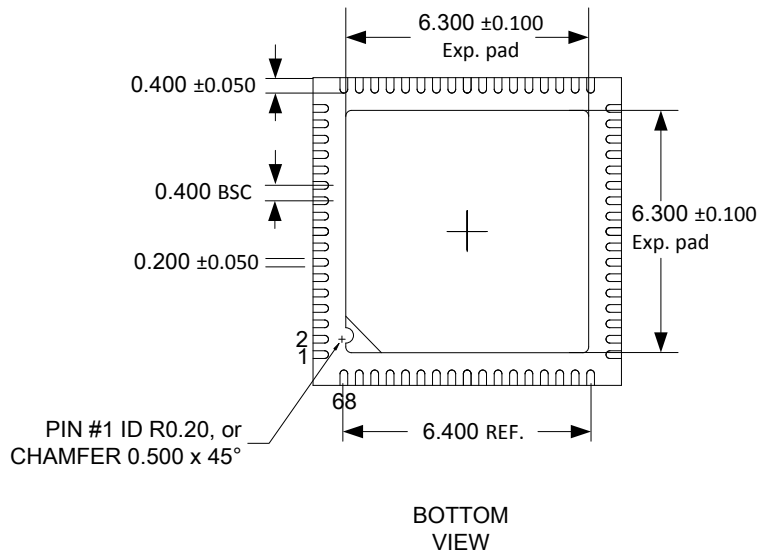

Figure 47: QFN-68 Package Outline, Bottom View

* Pin length is nominally 0.4 mm (min = 0.3 mm, max = 0.4 mm).

** Exposed pad is internally connected to GNDD.

*** Pin 1 is marked on bottom with notch or chamfered corner in the exposed pad next to pin 1.

5.7.2 71M6531D/F Pinout (QFN-68)

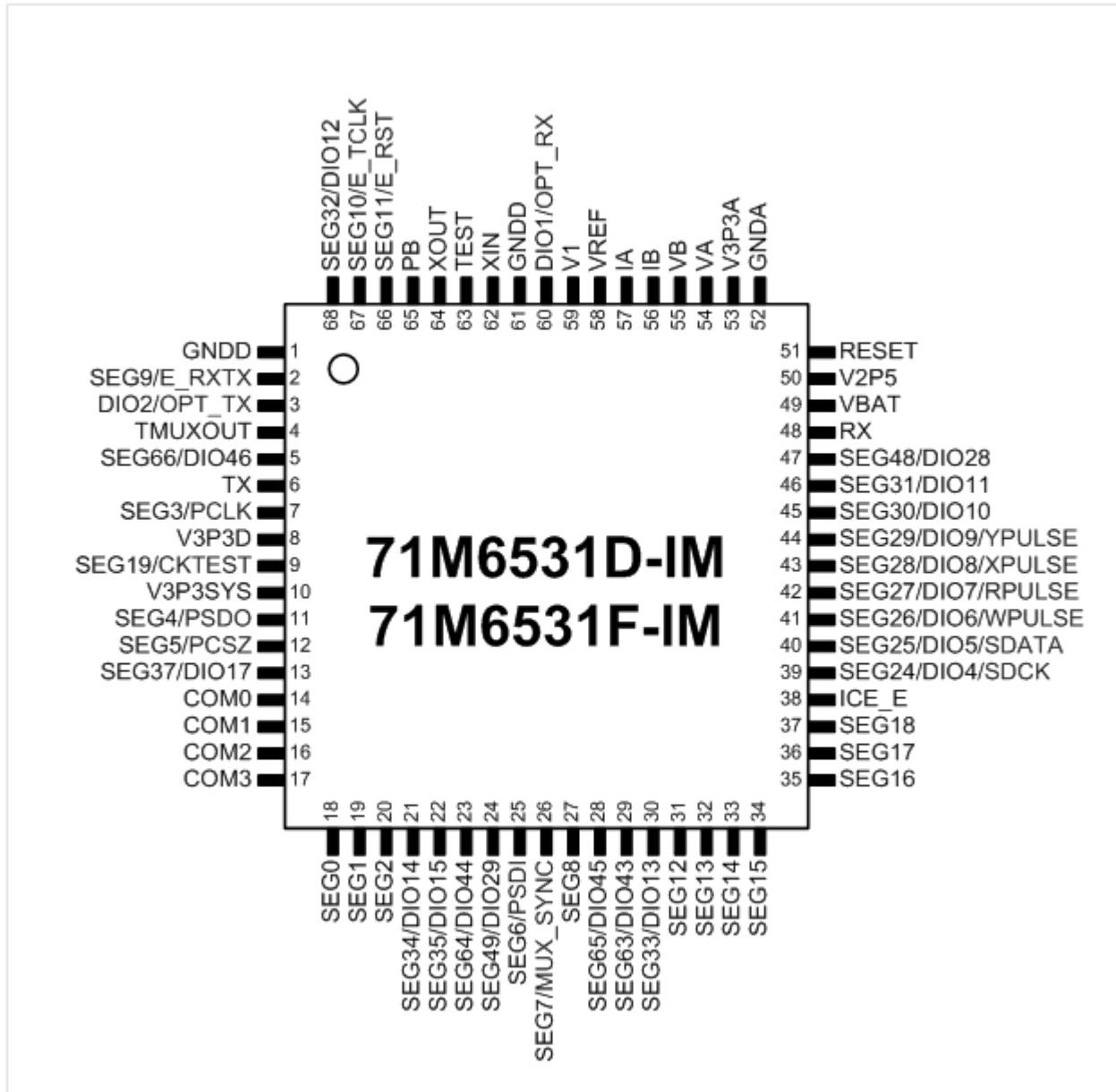

Figure 48: Pinout for QFN-68 Package

5.7.3 Recommended PCB Land Pattern for the QFN-68 Package

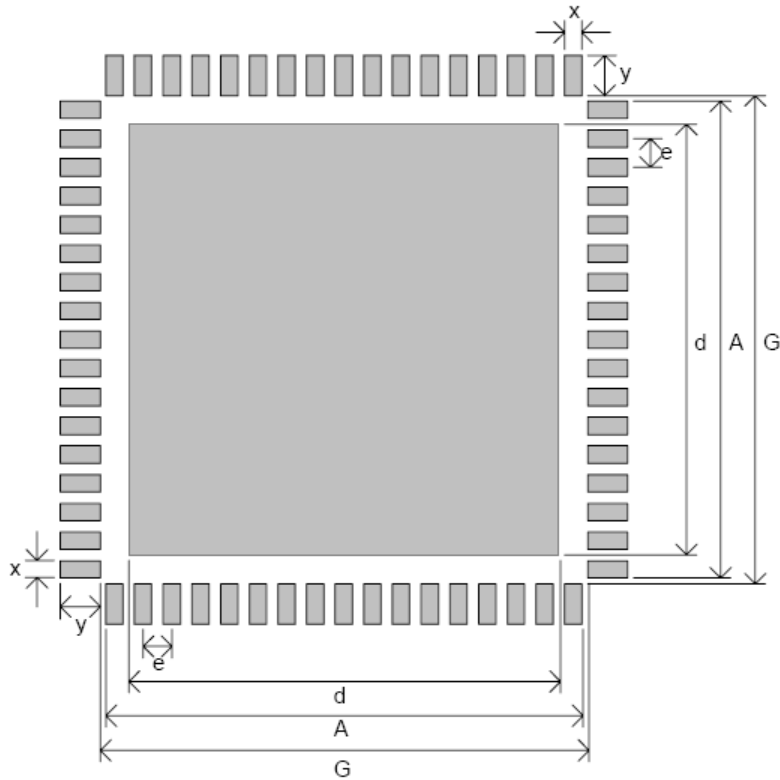

Figure 49: PCB Land Pattern for QFN 68 Package

Table 89: Recommended PCB Land Pattern Dimensions

Symbol	Description	Typical Dimension
e	Lead pitch	0.4mm
x	Pad width	0.23mm
y	Pad length, see note 3	0.8mm
d	See note 1	6.3mm
A		6.63mm
G		7.2mm

Notes:

1. Do not place unmasked vias in the region denoted by dimension d.
2. Soldering of bottom internal pad is not required for proper operation.
3. The y dimension has been elongated to allow for hand soldering and reworking. Production assembly may allow this dimension to be reduced as long as the G dimension is maintained.

5.8 71M6532D/F Package

5.8.1 71M6532D/F Pinout (LQFP-100)

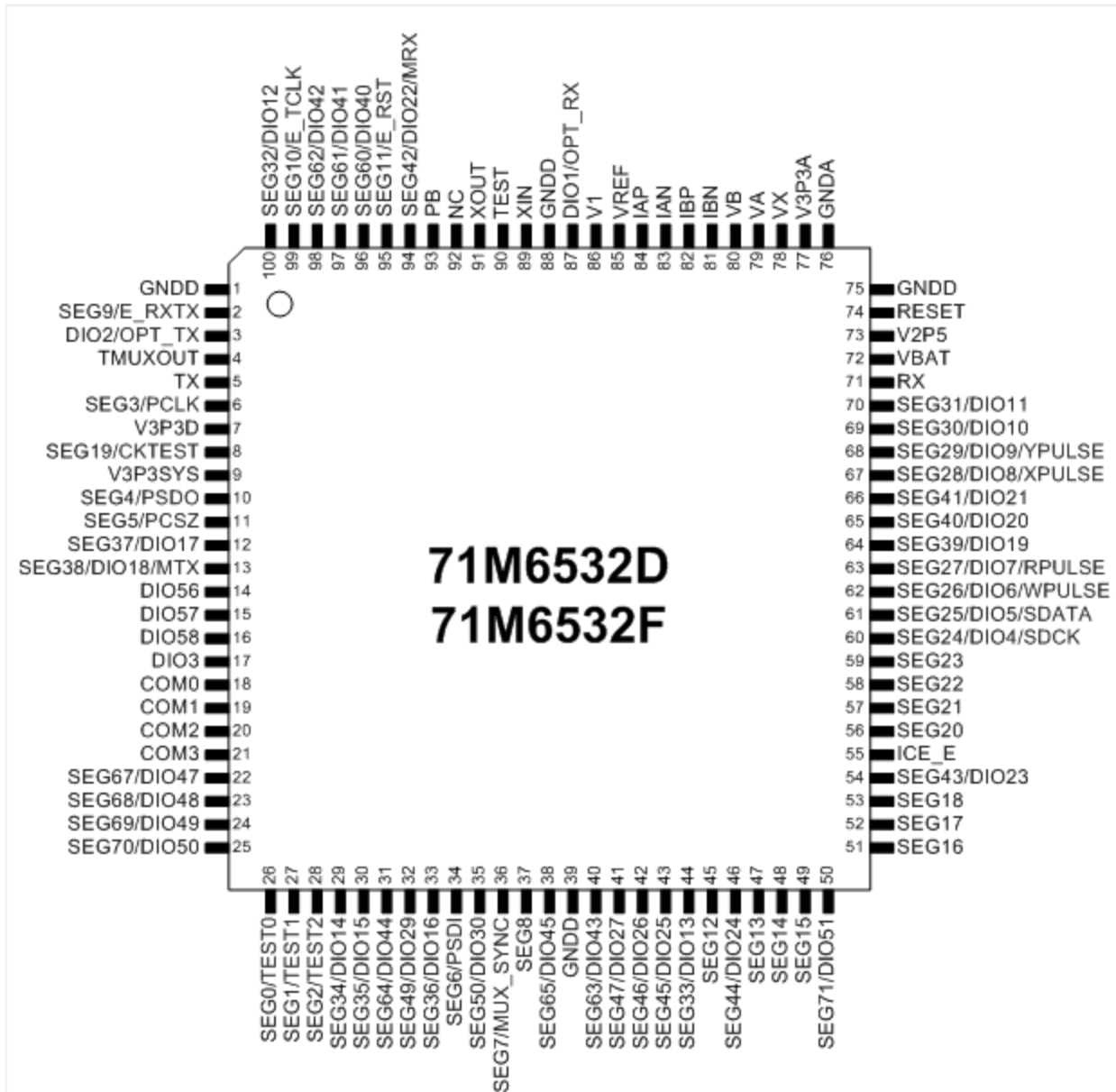

Figure 50: PCB Land Pattern for LQFP-100 Package

5.8.2 LQFP-100 Mechanical Drawing

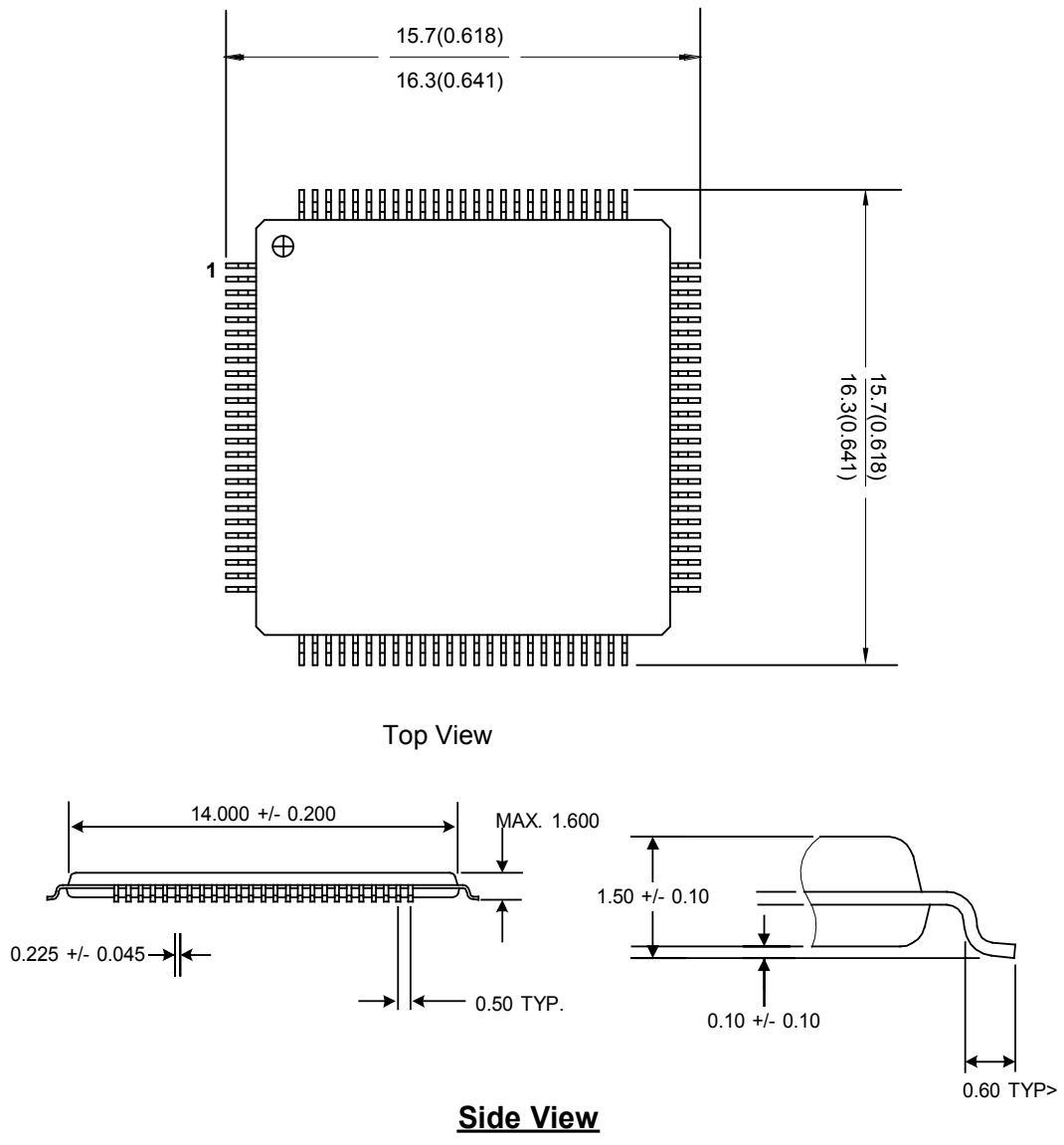

Figure 51: LQFP-100 Package, Mechanical Drawing
(Dimensions are in mm.)

5.9 Pin Descriptions

Pin types: P = Power, O = Output, I = Input, I/O = Input/Output

The circuit number denotes the equivalent circuit, as specified under Section 5.9.4 I/O Equivalent Circuits.

5.9.1 Power and Ground Pins

Table 90: Power and Ground Pins

Name	Type	Circuit	Description
GNDA	P	–	Analog ground: This pin should be connected directly to the ground plane.
GNDD	P	–	Digital ground: This pin should be connected directly to the ground plane.
V3P3A	P	–	Analog power supply: A 3.3 V power supply should be connected to this pin, must be the same voltage as V3P3SYS.
V3P3SYS	P	–	System 3.3 V supply. This pin should be connected to a 3.3 V power supply.
V3P3D	O	13	Auxiliary voltage output of the chip, controlled by the internal 3.3 V selection switch. In mission mode, this pin is internally connected to V3P3SYS. In BROWNOUT mode, it is internally connected to VBAT. This pin is floating in LCD and SLEEP mode. A bypass capacitor to ground should not exceed 0.1 μ F.
VBAT	P	12	Battery backup and oscillator power supply. A battery or super-capacitor is to be connected between VBAT and GNDD. If no battery is used, connect VBAT to V3P3SYS.
V2P5	O	10	Output of the internal 2.5 V regulator. A 0.1 μ F capacitor to GNDA should be connected to this pin.

5.9.2 Analog Pins

Table 91: Analog Pins

Name	Type	Circuit	Description
IA, IB IAP/IAN, IBP/IBN ¹⁾	I	6	Line Current Sense Inputs: These pins are voltage inputs to the internal A/D converter. Typically, they are connected to the outputs of current sensors. Unused pins must be tied to V3P3A.
VA, VB, VX ¹⁾	I	6	Line Voltage Sense Inputs: These pins are voltage inputs to the internal A/D converter. Typically, they are connected to the outputs of resistor dividers. Unused pins must be tied to V3P3A. The VX pin is not supported by standard CE code.
V1	I	7	Comparator Input: This pin is a voltage input to the internal comparator. The voltage applied to the pin is compared to the internal BIAS voltage (1.6 V). If the input voltage is above VBIAS, the comparator output will be high (1). If the comparator output is low, a voltage fault will occur. A series resistor should be connected from V1 to the resistor divider to provide hysteresis.
VREF	O	9	Voltage Reference for the ADC. Normally disabled and left unconnected. If enabled, a 0.1 μ F capacitor to V3P3A should be connected to this pin.
XIN XOUT	I	8	Crystal Inputs: A 32 kHz crystal should be connected across these pins. Typically, a 33 pF capacitor is also connected from XIN to GNDA and a 15 pF capacitor is connected from XOUT to GNDA. It is important to minimize the capacitance between these pins. See the crystal manufacturer datasheet for details. If an external clock is used, a 150 mV (p-p) clock signal should be applied to XIN, and XOUT should be left unconnected.

¹⁾ Differential pin pairs IAP/IAN and IBP/IBN, as well as single-ended VX pin used on 71M6532D/F only.

5.9.3 Digital Pins

Table 92: Digital Pins

Name	Type	Circuit	Description
COM3,COM2, COM1,COM0	O	5	LCD Common Outputs: These 4 pins provide the select signals for the LCD display.
SEG0...SEG2, SEG7, SEG8 SEG12...SEG18	O	5	Dedicated LCD Segment Output pins.
SEG20...SEG23	O	5	Dedicated LCD Segment Output pins (71M6532D/F only).
SEG24/DIO4... SEG35/DIO15, SEG37/DIO17, SEG48/DIO28, SEG49/DIO29, SEG63/DIO43... SEG66/DIO46	I/O	3, 4, 5	Multi-use pins, configurable as either LCD SEG driver or DIO. (DIO4 = SCK, DIO5 = SDA when configured as EEPROM interface; WPULSE = DIO6, VARPULSE = DIO7 when configured as pulse outputs). Unused pins must be configured as outputs or terminated to V3P3/GNDD. ¹⁾
SEG3/PCLK SEG4/PSDO SEG5/PCSZ SEG6/PSDI	I/O	3, 4, 5	Multi-use pins, configurable as either LCD SEG driver or SPI PORT.
E_RXTX/SEG9	I/O	1, 4, 5	Multi-use pins, configurable as either emulator port pins (when ICE_E pulled high) or LCD SEG drivers (when ICE_E tied to GND).
E_RST/SEG11	I/O	1, 4, 5	
E_TCLK/SEG10	O	4, 5	
ICE_E	I	2	ICE enable. When zero, E_RST, E_TCLK and E_RXTX become SEG32, SEG33 and SEG38 respectively. For production units, this pin should be pulled to GND to disable the emulator port.
CKTEST/SEG19, MUXSYNC/SEG7	O	4, 5	Multi-use pins, configurable as either multiplexer/clock output or LCD segment driver using the I/O RAM registers <i>CKOUT_E</i> or <i>MUX_SYNC_E</i> .
TMUXOUT	O	4	Digital output test multiplexer. Controlled by <i>TMUX[3:0]</i> .
OPT_RX/DIO1	I/O	3, 4, 7	Multi-use pin, configurable as Optical Receive Input or general DIO. When configured as OPT_RX, this pin receives a signal from an external photo-detector used in an IR serial interface. If this pin is unused it must be configured as an output or terminated to V3P3D or GNDD.
OPT_TX/DIO2	I/O	3, 4	Multi-use pin, configurable as either optical LED transmit output, WPULSE, RPULSE, or general DIO. When configured as OPT_TX, this pin is capable of directly driving an LED for transmitting data in an IR serial interface.
RESET	I	2	Chip reset: This input pin is used to reset the chip into a known state. For normal operation, this pin is pulled low. To reset the chip, this pin should be pulled high. This pin has an internal 30 μ A (nominal) current source pull-down. No external reset circuitry is necessary.
RX	I	3	UART input. If this pin is unused it must be configured as an output or terminated to V3P3D or GNDD.
TX	O	4	UART output.
TEST	I	7	Enables Production Test. This pin must be grounded in normal operation.
PB	I	3	Push button input. This pin must be at GNDD when not active. A rising edge sets the <i>IE_PB</i> flag. It also causes the part to wake up if it is in SLEEP or LCD mode. PB does not have an internal pull-up or pull-down.

¹⁾ Not all pins available on the 71M6531D/F or 71M6532D/F.

5.9.4 I/O Equivalent Circuits

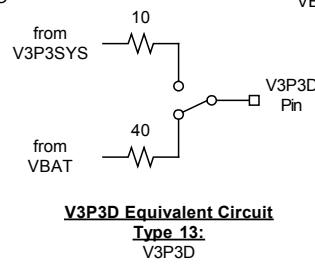
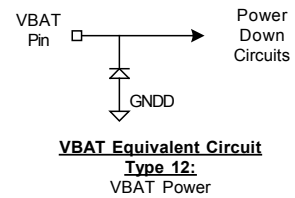
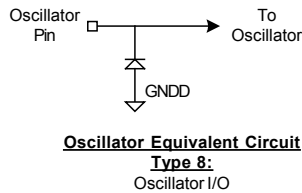
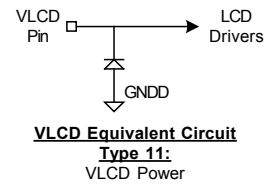
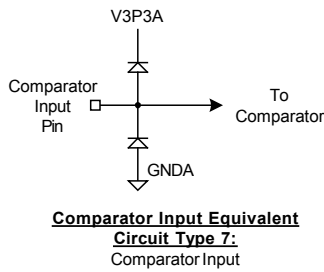
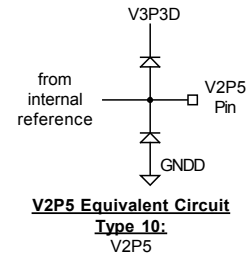
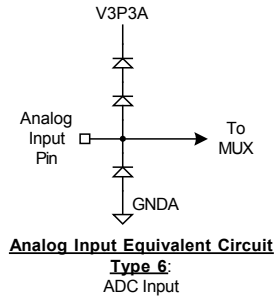
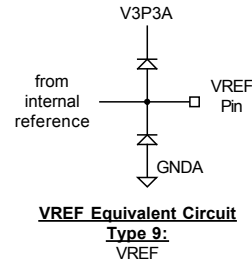
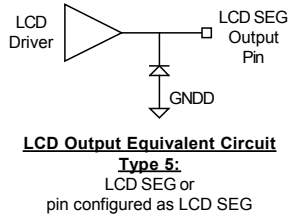
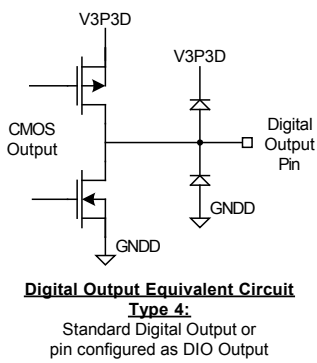
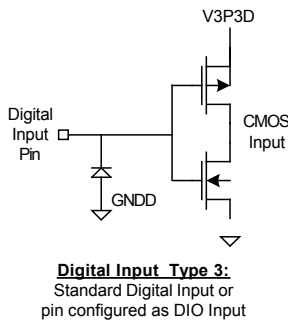
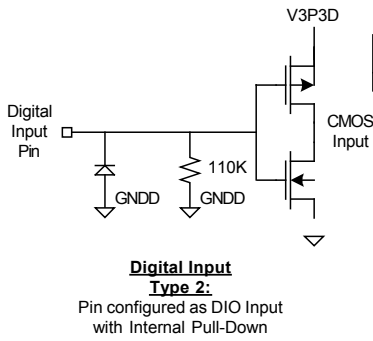
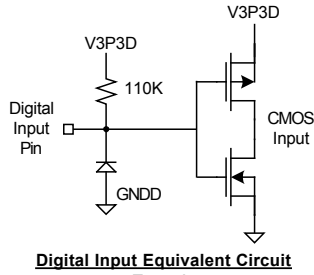

Figure 52: I/O Equivalent Circuits

6 Ordering Information

Part	Part Description (Package)	Flash Size	Packaging	Order Number	Package Marking
71M6531D	68-pin QFN, lead free	128 KB	Bulk	71M6531D-IM/F	71M6531D-IM
71M6531D		128 KB	Tape and reel	71M6531D-IMR/F	71M6531D-IM
71M6531F		256 KB	Bulk	71M6531F-IM/F	71M6531F-IM
71M6531F		256 KB	Tape and reel	71M6531F-IMR/F	71M6531F-IM
71M6532D	100-pin LQFP, lead free	128 KB	Bulk	71M6532D-IGT/F	71M6532D-IGT
71M6532D		128 KB	Tape and reel	71M6532D-IGTR/F	71M6532D-IGT
71M6532F		256 KB	Bulk	71M6532F-IGT/F	71M6532F-IGT
71M6532F		256 KB	Tape and reel	71M6532F-IGTR/F	71M6532F-IGT

7 Related Information

Users must also refer to the following documents related to the 71M6531D/F and 71M6532D/F:

- *71M653X Software User's Guide (SUG_653X)*
- *Demo Board User's Guide (DBUM_6531)*
- *Application Note on Migration from the 6521 to the 6531 (AN_6531_001)*

Other essential application notes can be found at the Maxim web site:

<http://www.maximintegrated.com/datasheet/index.mvp/id/6854/t/do>

8 Contact Information

For more information about Maxim products or to check the availability of the 71M6531D/F and 71M6532D/F, contact technical support at <https://support.maximintegrated.com>.

Appendix A: Acronyms

AFE	Analog Front End
AMR	Automatic Meter Reading
ANSI	American National Standards Institute
CE	Compute Engine
DIO	Digital I /O
DSP	Digital Signal Processor
FIR	Finite Impulse Response
I ² C	Inter-IC Bus
ICE	In-Circuit Emulator
IEC	International Electrotechnical Commission
MPU	Microprocessor Unit (CPU)
PLL	Phase-locked loop
RMS	Root Mean Square
SFR	Special Function Register
SOC	System on Chip
SPI	Serial Peripheral Interface
TOU	Time of Use
UART	Universal Asynchronous Receiver/Transmitter

Appendix B: Revision History

Revision	Date	Description
2	March 26, 2013	<ol style="list-style-type: none"> 1) Added Guaranteed By Design notes to the Electrical Specifications (Section 5). 2) Added explanation on NV properties of <i>RTCA_ADJ</i> [] and <i>PREG/QREG</i> [] (Section 1.5.3) and corrected entries in Table 55. 3) Added note that transitions to BROWNOUT mode must be avoided during page erase operations (Section 1.5.5). 4) Added note in Application Section 3.1 stating that filter components other than those shown on the Demo Boards should not be connected to the sensor input pins. Added reference to AN5292. 5) Consolidated spelling of low-power modes (SLEEP, BROWNOUT) and of <i>COMPSTAT</i> register. 6) Corrected value for C2 capacitor in Table 68. 7) Extended explanation of <i>WD_OVF</i> (not preserved in SLEEP mode) and corrected entries in Table 55. 8) Added explanation of <i>WD_NROVF_FLAG</i> (Section 1.4.9). 9) Added explanation of MPU activity on transition to BROWNOUT mode in Section 2.4.2. 10) Swapped the order of the Individual Flags and Individual Enable Bits in Figure 8.
1.3	June 9, 2010	<ol style="list-style-type: none"> 1) Throughout document: Added bit ranges to all register fields where missing (e.g. <i>MPU_DIV</i>[2:0]). 2) Figure 1, Figure 2: corrected name for PSDI and PSDO signals. 3) 1.4 80515 MPU Core <ul style="list-style-type: none"> • Added SFR register addresses where needed. • (Page 19) Table 6: Change approximate frequencies to exact frequencies. • (Page 19) Changed providing Library to providing demonstration source code. • (Page 20) Added note about <i>MUX_DIV</i>=0 disables ADC output. • (Page 21) See restrictions on INTBITS register. • (Page 22) Added <i>PI-P3</i> to Table 10. • (Page 23) Updated Data Pointer description. • (Page 24) Table 14: Updated description for <i>FWCOL0</i>, <i>FWCOL1</i>. • (Page 26) 1.4.6 UARTs: Clarified <i>SOBUF</i>, <i>SIBUF</i> as Tx and Rx buffers. • (Page 27) Added caution on proper way to clear flag bits. • (Page 30) 1.4.9 Interrupts: Clarified External vs Internal interrupts. • (Page 31) Table 25: Added Interrupt sources for Ext. Interrupts 2-6. 4) 1.5.2 Internal Clocks <ul style="list-style-type: none"> • (Page 36) Table 37: Changed frequencies to exact frequencies. • (Page 38) Added caution concerning frequency relationship to specific CE code. 5) 1.5.3 Real-Time Clock (RTC): (Page 39) Added description for observing RTC timing on TMUXOUT pin, corrected values for <i>RTCA_ADJ</i>, and achievable frequency step. 6) 1.5.9 Digital IO – Common Characteristics for 71M6531D/F and 71M6532D/F (Page 45): <ul style="list-style-type: none"> • Added caution about not sourcing current in or out of DIO pins. • Updated Figure 10 : Connecting an External Load to DIO Pins. 7) 1.5.13 Battery Monitor (Page 46): Corrected RAM address for ADC data. 8) 1.5.15 SPI Slave Port (page 49): Clarified description of I/O RAM

		<p>access via the SPI interface. Added Table 50.</p> <p>9) 2.3 Battery Modes (page 56, 57): Added details on software precautions for switching between modes and factory programming of the first 6 flash addresses.</p> <p>10) 3.1 Connection of Sensors (page 63): Added note concerning analog input pins requiring sensors with low source impedance.</p> <p>11) 3.15 MPU Firmware (page 70): Modified to indicate demonstration source code provided.</p> <p>12) 3.16 Crystal Oscillator (page 70): Updated caution concerning rejecting electromagnetic interference.</p> <p>13) Table 54: I/O RAM Map in Functional Order (page 72): Updated Unused and NVRAM locations.</p> <p>14) 4.3.4 Environment: Added comment concerning importance of parameter dependence on CE code environment.</p> <p>15) 4.3.6 CE Status and Control (page 89):</p> <ul style="list-style-type: none"> • Updated description of <i>F0</i> in Table 57. • Updated descriptions in Table 58 (page 91). <p>16) 4.3.7 CE Transfer Variables: Updated description of <i>VBAT_SUM_X</i> in Table 63 (page 93).</p> <p>17) Corrected values for <i>EXT_PULSE</i> in description of internal pulse generation (page 89).</p> <p>18) Updated pin-out for QFN-68 package (Figure 48).</p> <p>19) Added explanation for <i>InSQRES_X</i>.</p> <p>20) Added explanation of delay compensation in CE (1.3.5).</p> <p>21) Added explanation on temperature coefficients for VREF in Application Section (3.4.1).</p> <p>22) Corrected Figure 30 (right side).</p>
1.2	October 21, 2009	<p>Updated number range for <i>RTC_ADJ</i> to 0 – 0x7F and tolerance for exposed pad in Figure 46 to 0.1 mm. Corrected bit range for <i>CE_LCTN</i> to <i>[7:0]</i> and functional description for <i>TMOD[7]</i> and <i>TMOD[3]</i> in Table 22. Added maximum value for <i>WRATE</i> and text stating that registers <i>RTC_SEC</i> to <i>RTC_YR</i> do not change at reset. Added V LSB entry for sag detection in CE Interface Description, text regarding hysteresis at section 3.10, note that VX pin is not supported by standard CE code, and description of <i>STOP</i> and <i>IDLE</i> bits in <i>PCON</i> register. Changed value for Wh accuracy percentage on title page (value stated for room temperature).</p>
1.1	July 27, 2009	<p>Updated mechanical drawing for QFN-68 package. Replaced Figure 19 with single-phase example. Corrected LQFP-100 package drawing (Figure 50). Applied minor corrections and enhancements to diagrams.</p>
1.0	February 27, 2009	<p>Initial release. Changes with respect to PDS v1.3:</p> <ol style="list-style-type: none"> 1) Corrected Timer/Counter 0/1 label in Table 22. 2) Corrected entries for DIO29 and DIO43 in Table 39. 3) Updated unused/reserved bits in I/O RAM tables, added description for <i>WE</i> register. 4) Documented blink capability for both SEG18 and SEG19. 5) Changed package for 71M6532D/F to LQFP-100, updated all pin tables and I/O RAM tables accordingly. 6) Replaced graph showing system performance specification over temperature with specification on accuracy of VREF compensation. 7) Added explanation for hysteresis at the V1 pin in Applications Section. 8) Added note on recommended bypass capacitors C1 and C2 in Electrical Specification.

		<ul style="list-style-type: none">9) Removed access to I/O RAM from SPI Port description.10) Updated numerous parameters in Electrical Specification (temperature sensor, supply current for mission and battery modes).11) Corrected number of pre-boot cycles in Flash Memory Section.12) Updated entries in I/O RAM table under "Wake" column.
--	--	--



Maxim Integrated cannot assume responsibility for use of any circuitry other than circuitry entirely embodied in a Maxim Integrated product. No circuit patent licenses are implied. Maxim Integrated reserves the right to change the circuitry and specifications without notice at any time. The parametric values (min and max limits) shown in the Electrical Characteristics table are guaranteed. Other parametric values quoted in this data sheet are provided for guidance.

Maxim Integrated 160 Rio Robles, San Jose, CA 95134 USA 1-408-601-1000

© 2012 Maxim Integrated Products, Inc. Maxim Integrated and the Maxim Integrated logo are trademarks of Maxim Integrated Products, Inc.

Looking for pricing, stock, or lifecycle information?

Click below to explore more details on WIN SOURCE:

 [View 71M6531F-IMR/F on WIN SOURCE](#)

 [Maxim Integrated Information](#)

Optimize Your Supply Chain with WIN SOURCE Solutions

-  Global Sourcing Solution
-  Obsolete Management
-  Cost Control Management
-  Shortage Management
-  Alternative Solution
-  Excess Inventory Management