



**THE DATASHEET OF
9FGV0831CKILFT**



Description

The 9FGV0831 is a member of IDT's SOC-friendly 1.8V very low-power PCIe clock family. The device has 8 output enables for clock management, 2 different spread spectrum levels in addition to spread off, and 2 selectable SMBus addresses.

Recommended Application

PCIe Gen1–4 clock generation for Riser Cards, Storage, Networking, JBOD, Communications, Access Points

Output Features

- 8 100MHz Low-Power (LP) HCSL DIF pair
- 1 1.8V LVCMOS REF output with Wake-On-LAN (WOL) support

Key Specifications

- DIF cycle-to-cycle jitter <50ps
- DIF output-to-output skew <50ps
- DIF phase jitter is PCIe Gen1-2-3-4 compliant
- REF phase jitter is <1.5ps RMS

Features/Benefits

- LP-HCSL outputs; saves 16 resistors compared to standard PCIe devices
- 62mW typical power consumption; reduced thermal concerns
- Outputs can optionally be supplied from any voltage between 1.05 and 1.8V; maximum power savings
- OE# pins; support DIF power management
- Programmable slew rate for each output; allows tuning for various line lengths
- Programmable output amplitude; allows tuning for various application environments
- DIF outputs blocked until PLL is locked; clean system start-up
- Selectable 0%, -0.25% or -0.5% spread on DIF outputs; reduces EMI
- External 25MHz crystal; supports tight ppm with 0 ppm synthesis error
- Configuration can be accomplished with strapping pins; SMBus interface not required for device control
- 3.3V tolerant SMBus interface works with legacy controllers
- Selectable SMBus addresses; multiple devices can easily share an SMBus segment
- Space saving 6 x 6 mm 48-VFQFPN; minimal board space

Block Diagram

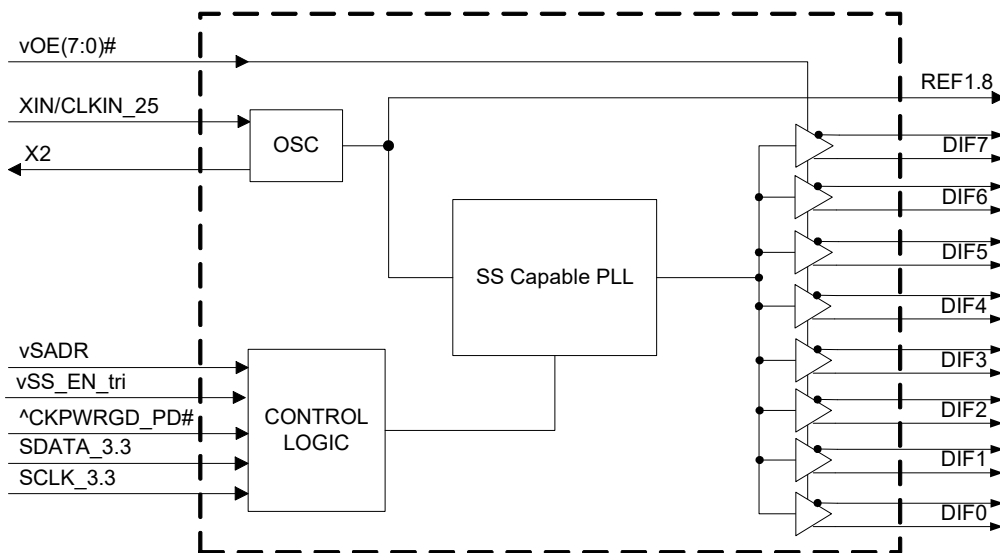

Pin Configuration

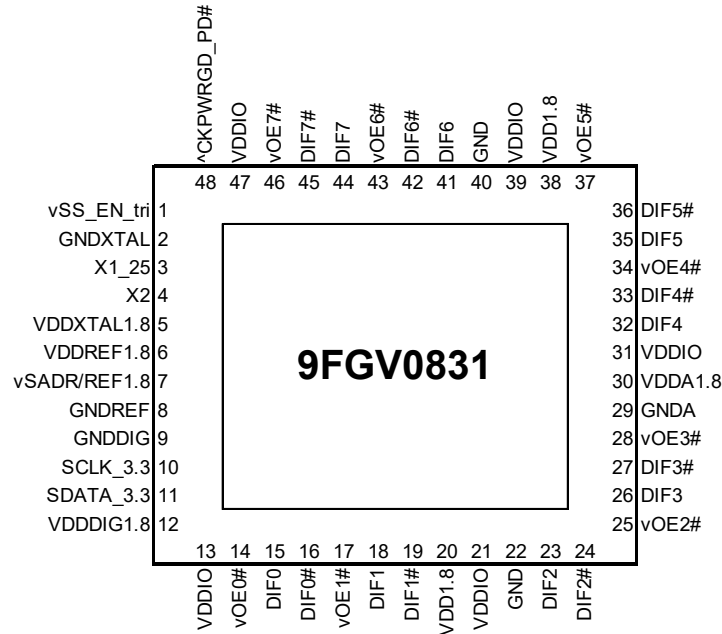

6 x 6 mm 48-VFQFPN, 0.4mm pitch

vv prefix indicates internal 60kOhm pull-down resistor
 v prefix indicates internal 120kOhm pull-down resistor
 ^ prefix indicates internal 120kOhm pull-up resistor

SMBus Address Selection Table

	SADR	Address	+ Read/Write Bit
State of SADR on first application of CKPWRGD_PD#	0	1101000	x
	1	1101010	x

Power Management Table

CKPWRGD_PD#	SMBus OE bit	DIFx			REF
		OEx#	True O/P	Comp. O/P	
0	X	X	Low	Low	Hi-Z ¹
1	1	0	Running	Running	Running
1	0	1	Low	Low	Low

1. REF is Hi-Z until the 1st assertion of CKPWRGD_PD# high. After this, when CKPWRGD_PD# is low, REF is Low.

Power Connections

Pin Number			Description
VDD	VDDIO	GND	
5		2	XTAL OSC
6		8	REF Power
12		9	Digital (dirty) Power
20,38	13,21,31,39,47	22,29,40	DIF outputs
30		29	PLL Analog

Pin Descriptions

PIN #	PIN NAME	TYPE	DESCRIPTION
1	vSS_EN_tri	LATCHED IN	Latched select input to select spread spectrum amount at initial power up : 1 = -0.5% spread, M = -0.25%, 0 = Spread Off
2	GNDXTAL	GND	GND for XTAL
3	X1_25	IN	Crystal input, Nominally 25.00MHz.
4	X2	OUT	Crystal output.
5	VDDXTAL1.8	PWR	Power supply for XTAL, nominal 1.8V
6	VDDREF1.8	PWR	VDD for REF output. nominal 1.8V.
7	vSADR/REF1.8	LATCHED I/O	Latch to select SMBus Address/1.8V LVCMOS copy of X1/REFIN pin
8	GNDREF	GND	Ground pin for the REF outputs.
9	GNDDIG	GND	Ground pin for digital circuitry
10	SCLK_3.3	IN	Clock pin of SMBus circuitry, 3.3V tolerant.
11	SDATA_3.3	I/O	Data pin for SMBus circuitry, 3.3V tolerant.
12	VDDDIG1.8	PWR	1.8V digital power (dirty power)
13	VDDIO	PWR	Power supply for differential outputs
14	vOE0#	IN	Active low input for enabling DIF pair 0. This pin has an internal pull-down. 1 =disable outputs, 0 = enable outputs
15	DIF0	OUT	Differential true clock output
16	DIF0#	OUT	Differential Complementary clock output
17	vOE1#	IN	Active low input for enabling DIF pair 1. This pin has an internal pull-down. 1 =disable outputs, 0 = enable outputs
18	DIF1	OUT	Differential true clock output
19	DIF1#	OUT	Differential Complementary clock output
20	VDD1.8	PWR	Power supply, nominal 1.8V
21	VDDIO	PWR	Power supply for differential outputs
22	GND	GND	Ground pin.
23	DIF2	OUT	Differential true clock output
24	DIF2#	OUT	Differential Complementary clock output
25	vOE2#	IN	Active low input for enabling DIF pair 2. This pin has an internal pull-down. 1 =disable outputs, 0 = enable outputs
26	DIF3	OUT	Differential true clock output
27	DIF3#	OUT	Differential Complementary clock output
28	vOE3#	IN	Active low input for enabling DIF pair 3. This pin has an internal pull-down. 1 =disable outputs, 0 = enable outputs
29	GND A	GND	Ground pin for the PLL core.
30	VDDA1.8	PWR	1.8V power for the PLL core.
31	VDDIO	PWR	Power supply for differential outputs
32	DIF4	OUT	Differential true clock output
33	DIF4#	OUT	Differential Complementary clock output
34	vOE4#	IN	Active low input for enabling DIF pair 4. This pin has an internal pull-down. 1 =disable outputs, 0 = enable outputs
35	DIF5	OUT	Differential true clock output
36	DIF5#	OUT	Differential Complementary clock output
37	vOE5#	IN	Active low input for enabling DIF pair 5. This pin has an internal pull-down. 1 =disable outputs, 0 = enable outputs
38	VDD1.8	PWR	Power supply, nominal 1.8V
39	VDDIO	PWR	Power supply for differential outputs

Pin Descriptions (cont.)

PIN #	PIN NAME	TYPE	DESCRIPTION
40	GND	GND	Ground pin.
41	DIF6	OUT	Differential true clock output
42	DIF6#	OUT	Differential Complementary clock output
43	vOE6#	IN	Active low input for enabling DIF pair 6. This pin has an internal pull-down. 1 =disable outputs, 0 = enable outputs
44	DIF7	OUT	Differential true clock output
45	DIF7#	OUT	Differential Complementary clock output
46	vOE7#	IN	Active low input for enabling DIF pair 7. This pin has an internal pull-down. 1 =disable outputs, 0 = enable outputs
47	VDDIO	PWR	Power supply for differential outputs
48	^CKPWRGD_PD#	IN	Input notifies device to sample latched inputs and start up on first high assertion. Low enters Power Down Mode, subsequent high assertions exit Power Down Mode. This pin has internal pull-up resistor.

Test Loads

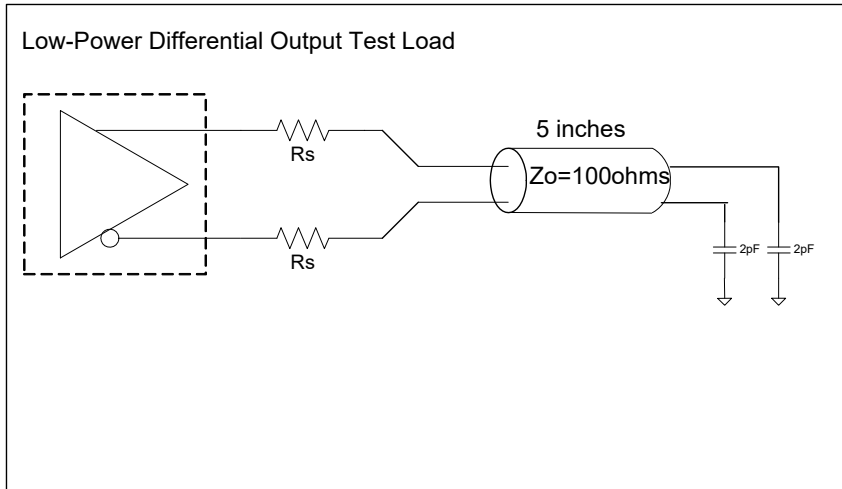

Alternate Differential Output Terminations

Rs	Zo	Units
33	100	Ohms
27	85	

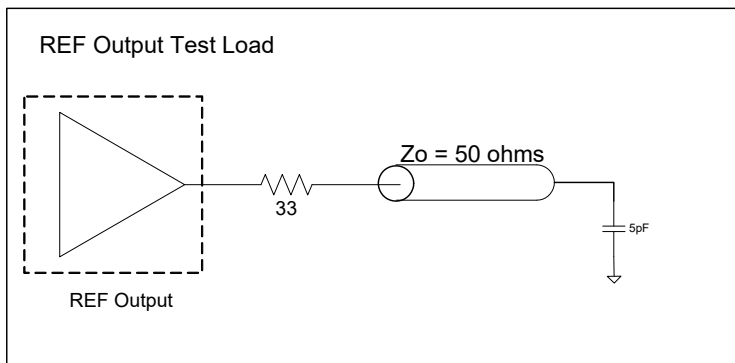

Alternate Terminations

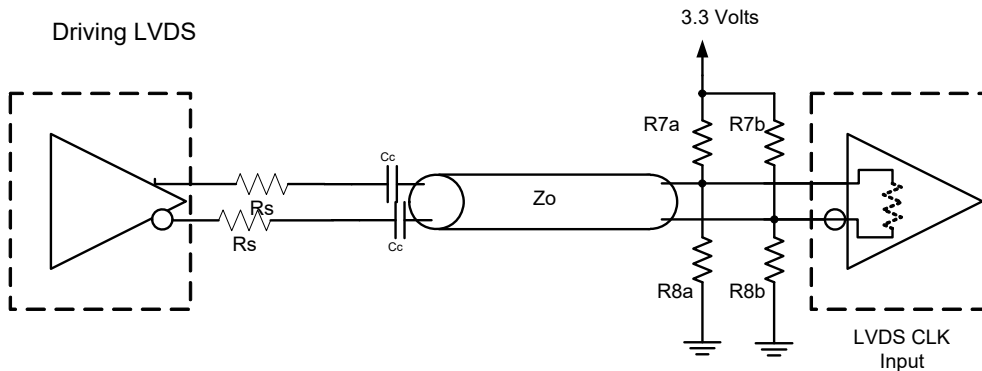

Driving LVDS inputs

Component	Value		Note
	Receiver has termination	Receiver does not have termination	
R7a, R7b	10K ohm	140 ohm	
R8a, R8b	5.6K ohm	75 ohm	
Cc	0.1 uF	0.1 uF	
Vcm	1.2 volts	1.2 volts	

Absolute Maximum Ratings

Stresses above the ratings listed below can cause permanent damage to the 9FGV0831. These ratings, which are standard values for IDT commercially rated parts, are stress ratings only. Functional operation of the device at these or any other conditions above those indicated in the operational sections of the specifications is not implied. Exposure to absolute maximum rating conditions for extended periods can affect product reliability. Electrical parameters are guaranteed only over the recommended operating temperature range.

PARAMETER	SYMBOL	CONDITIONS	MIN	TYP	MAX	UNITS	NOTES
Supply Voltage	VDDxx	Applies to all VDD pins	-0.5		2.5	V	1,2
Input Voltage	V _{IN}		-0.5		V _{DD} +0.5V	V	1, 3
Input High Voltage, SMBus	V _{IHSMB}	SMBus clock and data pins			3.6V	V	1
Storage Temperature	T _s		-65		150	°C	1
Junction Temperature	T _j				125	°C	1
Input ESD protection	ESD prot	Human Body Model	2000			V	1

¹Guaranteed by design and characterization, not 100% tested in production.

²Operation under these conditions is neither implied nor guaranteed.

³Not to exceed 2.5V.

Electrical Characteristics—Current Consumption

TA = T_{AMB}; Supply Voltages per normal operation conditions, See Test Loads for Loading Conditions

PARAMETER	SYMBOL	CONDITIONS	MIN	TYP	MAX	UNITS	NOTES
Operating Supply Current	I _{DDAOP}	VDDA, All outputs active @100MHz		6	9	mA	
	I _{DDOP}	All VDD, except VDDA and VDDIO, All outputs active @100MHz		12	15	mA	
	I _{DDIOOP}	VDDIO, All outputs active @100MHz		28	36	mA	
Wake-on-LAN Current (CKPWRGD_PD# = '0' Byte 3, bit 5 = '1')	I _{DDAPD}	VDDA, DIF outputs off, REF output running		0.4	1	mA	2
	I _{DDPD}	All VDD, except VDDA and VDDIO, DIF outputs off, REF output running		5.5	9	mA	2
	I _{DDIOPD}	VDDIO, DIF outputs off, REF output running		0.04	0.1	mA	2
Powerdown Current (CKPWRGD_PD# = '0' Byte 3, bit 5 = '0')	I _{DDAPD}	VDDA, all outputs off		0.4	1	mA	
	I _{DDPD}	All VDD, except VDDA and VDDIO, all outputs off		0.6	1	mA	
	I _{DDIOPD}	VDDIO, all outputs off		0.0003	0.1	mA	

¹Guaranteed by design and characterization, not 100% tested in production.

²This is the current required to have the REF output running in Wake-on-LAN mode (Byte 3, bit 5 = 1)

Electrical Characteristics—DIF Output Duty Cycle, Jitter, and Skew Characteristics

TA = T_{AMB}; Supply Voltages per normal operation conditions, See Test Loads for Loading Conditions

PARAMETER	SYMBOL	CONDITIONS	MIN	TYP	MAX	UNITS	NOTES
Duty Cycle	t _{DC}	Measured differentially, PLL Mode	45	49.9	55	%	1,2
Skew, Output to Output	t _{sk3}	Averaging on, V _T = 50%		37	50	ps	1,2
Jitter, Cycle to cycle	t _{jvc-cyc}			12	50	ps	1,2

¹Guaranteed by design and characterization, not 100% tested in production.

²Measured from differential waveform

Electrical Characteristics–Input/Supply/Common Parameters–Normal Operating Conditions

TA = T_{AMB}; Supply Voltages per normal operation conditions, See Test Loads for Loading Conditions

PARAMETER	SYMBOL	CONDITIONS	MIN	TYP	MAX	UNITS	NOTES
Supply Voltage	VDDxx	Supply voltage for core, analog and single-ended LVCMOS outputs	1.7	1.8	1.9	V	
Output Supply Voltage	VDDIO	Supply voltage for differential Low Power Outputs	0.9975	1.05-1.8	1.9	V	
Ambient Operating Temperature	T _{AMB}	Commercial range	0	25	70	°C	
		Industrial range	-40	25	85	°C	
Input High Voltage	V _{IH}	Single-ended inputs, except SMBus	0.75 V _{DD}		V _{DD} + 0.3	V	
Input Mid Voltage	V _{IM}	Single-ended tri-level inputs ('_tri' suffix)	0.4 V _{DD}	0.5 V _{DD}	0.6 V _{DD}	V	
Input Low Voltage	V _{IL}	Single-ended inputs, except SMBus	-0.3		0.25 V _{DD}	V	
Output High Voltage	V _{IH}	Single-ended outputs, except SMBus. I _{OH} = -2mA	V _{DD} -0.45			V	
Output Low Voltage	V _{IL}	Single-ended outputs, except SMBus. I _{OL} = -2mA			0.45	V	
Input Current	I _{IN}	Single-ended inputs, V _{IN} = GND, V _{IN} = VDD	-5		5	uA	
	I _{INP}	Single-ended inputs V _{IN} = 0 V; Inputs with internal pull-up resistors V _{IN} = VDD; Inputs with internal pull-down resistors	-20		20	uA	
Input Frequency	F _{in}	XTAL, or X1 input	23	25	27	MHz	
Pin Inductance	L _{pin}				7	nH	1
Capacitance	C _{IN}	Logic Inputs, except DIF_IN	1.5		5	pF	1
	C _{OUT}	Output pin capacitance			6	pF	1
Clk Stabilization	T _{STAB}	From V _{DD} Power-Up and after input clock stabilization or de-assertion of PD# to 1st clock		0.6	1.8	ms	1,2
SS Modulation Frequency	f _{MOD}	Allowable Frequency (Triangular Modulation)	30	31.6	33	kHz	1
OE# Latency	t _{LATOE#}	DIF start after OE# assertion DIF stop after OE# deassertion	1	3	3	clocks	1,3
Tdrive_PD#	t _{DRVPD}	DIF output enable after PD# de-assertion		20	300	us	1,3
Tfall	t _F	Fall time of single-ended control inputs			5	ns	2
Trise	t _R	Rise time of single-ended control inputs			5	ns	2
SMBus Input Low Voltage	V _{ILSMB}	V _{DD} SMB = 3.3V, see note 4 for V _{DD} SMB < 3.3V			0.6	V	
SMBus Input High Voltage	V _{IHSMB}	V _{DD} SMB = 3.3V, see note 5 for V _{DD} SMB < 3.3V	2.1		3.6	V	4
SMBus Output Low Voltage	V _{OLSMB}	@ I _{PULLUP}			0.4	V	
SMBus Sink Current	I _{PULLUP}	@ V _{OL}	4			mA	
Nominal Bus Voltage	V _{DD} SMB		1.7		3.6	V	
SCLK/SDATA Rise Time	t _{RSMB}	(Max VIL - 0.15) to (Min VIH + 0.15)			1000	ns	1
SCLK/SDATA Fall Time	t _{FSMB}	(Min VIH + 0.15) to (Max VIL - 0.15)			300	ns	1
SMBus Operating Frequency	f _{MAXSMB}	Maximum SMBus operating frequency			400	kHz	1

¹ Guaranteed by design and characterization, not 100% tested in production.

² Control input must be monotonic from 20% to 80% of input swing.

³ Time from deassertion until outputs are > 200mV.

⁴ For V_{DD}SMB < 3.3V, V_{IHSMB} >= 0.65xV_{DD}SMB.

Electrical Characteristics–DIF Low Power HCSL Outputs

TA = T_{AMB}; Supply Voltages per normal operation conditions, See Test Loads for Loading Conditions

PARAMETER	SYMBOL	CONDITIONS	MIN	TYP	MAX	UNITS	NOTES
Slew rate	Trf	Scope averaging on fast setting	1.8	2.7	4.4	V/ns	1,2,3
		Scope averaging on slow setting	1.4	2.1	3.4	V/ns	1,2,3
Slew rate matching	ΔTrf	Slew rate matching, Scope averaging on		4	20	%	1,2,4
Voltage High	V _{HIGH}	Statistical measurement on single-ended signal using oscilloscope math function. (Scope averaging on)	660	793	850	mV	7
Voltage Low	V _{LOW}		-150	16	150		7
Max Voltage	V _{max}	Measurement on single ended signal using absolute value. (Scope averaging off)		831	1150	mV	7
Min Voltage	V _{min}		-300	-95			7
Vswing	Vswing	Scope averaging off	300	1555		mV	1,2,7
Crossing Voltage (abs)	V _{cross_abs}	Scope averaging off	250	429	550	mV	1,5,7
Crossing Voltage (var)	Δ-V _{cross}	Scope averaging off		12	140	mV	1,6,7

¹Guaranteed by design and characterization, not 100% tested in production.

² Measured from differential waveform

³ Slew rate is measured through the Vswing voltage range centered around differential 0V. This results in a +/-150mV window around differential 0V.

⁴ Matching applies to rising edge rate for Clock and falling edge rate for Clock#. It is measured using a +/-75mV window centered on the average cross point where Clock rising meets Clock# falling. The median cross point is used to calculate the voltage thresholds the oscilloscope is to use for the edge rate calculations.

⁵ V_{cross} is defined as voltage where Clock = Clock# measured on a component test board and only applies to the differential rising edge (i.e. Clock rising and Clock# falling).

⁶ The total variation of all V_{cross} measurements in any particular system. Note that this is a subset of V_{cross_min}/max (V_{cross} absolute) allowed. The intent is to limit V_{cross} induced modulation by setting Δ-V_{cross} to be smaller than V_{cross} absolute.

⁷ At default SMBus amplitude settings.

Electrical Characteristics–Filtered Phase Jitter Parameters - PCIe Common Clocked (CC) Architectures

T_{AMB} = over the specified operating range. Supply Voltages per normal operation conditions, See Test Loads for Loading Conditions

SYMBOL	PARAMETER	CONDITIONS	MIN	TYP	MAX	Specification Limit	UNITS	NOTES
t _{jphPCIeG1-CC}	Phase Jitter, PLL Mode	PCIe Gen 1	21	25	35	86	ps (p-p)	1, 2, 3
t _{jphPCIeG2-CC}		PCIe Gen 2 Low Band 10kHz < f < 1.5MHz (PLL BW of 5-16MHz, 8-16MHz, CDR = 5MHz)	0.9	0.9	1.1	3	ps (rms)	1, 2
		PCIe Gen 2 High Band 1.5MHz < f < Nyquist (50MHz) (PLL BW of 5-16MHz, 8-16MHz, CDR = 5MHz)	1.5	1.6	1.9	3.1	ps (rms)	1, 2
t _{jphPCIeG3-CC}		PCIe Gen 3 (PLL BW of 2-4MHz, 2-5MHz, CDR = 10MHz)	0.3	0.37	0.44	1	ps (rms)	1, 2
t _{jphPCIeG4-CC}		PCIe Gen 4 (PLL BW of 2-4MHz, 2-5MHz, CDR = 10MHz)	0.3	0.37	0.44	0.5	ps (rms)	1, 2

Notes on PCIe Filtered Phase Jitter Table

¹ Applies to all differential outputs, guaranteed by design and characterization.

² Calculated from Intel-supplied Clock Jitter Tool, with spread on and off.

³ Sample size of at least 100K cycles. This figure extrapolates to 108ps pk-pk at 1M cycles for a BER of 1⁻¹².

Electrical Characteristics–REF

TA = T_{AMB}; Supply Voltages per normal operation conditions, See Test Loads for Loading Conditions

PARAMETER	SYMBOL	CONDITIONS	MIN	TYP	MAX	UNITS	Notes
Long Accuracy	ppm	see Tperiod min-max values		0		ppm	1,2
Clock period	T _{period}	25 MHz output		40		ns	2
Rise/Fall Slew Rate	t _{rr1}	Byte 3 = 1F, 20% to 80% of VDDREF	0.6	1	1.6	V/ns	1
Rise/Fall Slew Rate	t _{rr1}	Byte 3 = 5F, 20% to 80% of VDDREF	0.9	1.4	2.2	V/ns	1,3
Rise/Fall Slew Rate	t _{rr1}	Byte 3 = 9F, 20% to 80% of VDDREF	1.1	1.7	2.7	V/ns	1
Rise/Fall Slew Rate	t _{rr1}	Byte 3 = DF, 20% to 80% of VDDREF	1.1	1.8	2.9	V/ns	1
Duty Cycle	d _{t1X}	V _T = VDD/2 V	45	49.1	55	%	1,4
Duty Cycle Distortion	d _{tcd}	V _T = VDD/2 V	0	2	4	%	1,5
Jitter, cycle to cycle	t _{jvc-cyc}	V _T = VDD/2 V		19.1	250	ps	1,4
Noise floor	t _{dBc1k}	1kHz offset		-129.8	-105	dBc	1,4
Noise floor	t _{dBc10k}	10kHz offset to Nyquist		-143.6	-115	dBc	1,4
Jitter, phase	t _{jphREF}	12kHz to 5MHz		0.63	1.5	ps (rms)	1,4

¹Guaranteed by design and characterization, not 100% tested in production.

²All Long Term Accuracy and Clock Period specifications are guaranteed assuming that REF is trimmed to 25.00 MHz

³Default SMBus Value

⁴When driven by a crystal.

⁵When driven by an external oscillator via the X1 pin, X2 should be floating.

Clock Periods–Differential Outputs with Spread Spectrum Disabled

SSC OFF	Center Freq. MHz	Measurement Window							Units	Notes
		1 Clock	1us	0.1s	0.1s	0.1s	1us	1 Clock		
		-c2c jitter AbsPer Min	-SSC Short-Term Average Min	- ppm Long-Term Average Min	0 ppm Period Nominal	+ ppm Long-Term Average Max	+SSC Short-Term Average Max	+c2c jitter AbsPer Max		
DIF	100.00	9.94900		9.99900	10.00000	10.00100		10.05100	ns	1,2

Clock Periods–Differential Outputs with Spread Spectrum Enabled

SSC ON	Center Freq. MHz	Measurement Window							Units	Notes	
		1 Clock	1us	0.1s	0.1s	0.1s	1us	1 Clock			
		-c2c jitter AbsPer Min	-SSC Short-Term Average Min	- ppm Long-Term Average Min	0 ppm Period Nominal	+ ppm Long-Term Average Max	+SSC Short-Term Average Max	+c2c jitter AbsPer Max			
DIF	99.75	9.94906	9.99906	10.02406	10.02506	10.02607		10.05107	10.10107	ns	1,2

¹Guaranteed by design and characterization, not 100% tested in production.

²All Long Term Accuracy and Clock Period specifications are guaranteed assuming that REF is trimmed to 25.00 MHz

General SMBus Serial Interface Information

How to Write

- Controller (host) sends a start bit
- Controller (host) sends the write address
- IDT clock will **acknowledge**
- Controller (host) sends the beginning byte location = N
- IDT clock will **acknowledge**
- Controller (host) sends the byte count = X
- IDT clock will **acknowledge**
- Controller (host) starts sending Byte **N through Byte N+X-1**
- IDT clock will **acknowledge** each byte **one at a time**
- Controller (host) sends a stop bit

How to Read

- Controller (host) will send a start bit
- Controller (host) sends the write address
- IDT clock will **acknowledge**
- Controller (host) sends the beginning byte location = N
- IDT clock will **acknowledge**
- Controller (host) will send a separate start bit
- Controller (host) sends the read address
- IDT clock will **acknowledge**
- IDT clock will send the data byte count = X
- IDT clock sends Byte **N+X-1**
- IDT clock sends **Byte 0 through Byte X (if X_(H) was written to Byte 8)**
- Controller (host) will need to acknowledge each byte
- Controller (host) will send a not acknowledge bit
- Controller (host) will send a stop bit

Index Block Write Operation			
Controller (Host)			IDT (Slave/Receiver)
T	starT bit		
Slave Address			
WR	WRite		
Beginning Byte = N			ACK
			ACK
Data Byte Count = X			ACK
Beginning Byte N		X Byte	ACK
O			O
O			O
O			O
Byte N + X - 1			ACK
P	stoP bit		

Note: SMBus address is latched on SADR pin.

Index Block Read Operation			
Controller (Host)			IDT (Slave/Receiver)
T	starT bit		
Slave Address			
WR	WRite		
Beginning Byte = N			ACK
			ACK
RT	Repeat starT		
Slave Address			
RD	ReaD		ACK
ACK		X Byte	Data Byte Count=X
ACK			Beginning Byte N
O			O
O			O
O			O
			Byte N + X - 1
N	Not acknowledge		
P	stoP bit		

SMBus Table: Output Enable Register ¹

Byte 0	Name	Control Function	Type	0	1	Default
Bit 7	DIF OE7	Output Enable	RW	Low/Low	Enabled	1
Bit 6	DIF OE6	Output Enable	RW	Low/Low	Enabled	1
Bit 5	DIF OE5	Output Enable	RW	Low/Low	Enabled	1
Bit 4	DIF OE4	Output Enable	RW	Low/Low	Enabled	1
Bit 3	DIF OE3	Output Enable	RW	Low/Low	Enabled	1
Bit 2	DIF OE2	Output Enable	RW	Low/Low	Enabled	1
Bit 1	DIF OE1	Output Enable	RW	Low/Low	Enabled	1
Bit 0	DIF OE0	Output Enable	RW	Low/Low	Enabled	1

1. A low on these bits will override the OE# pin and force the differential output Low/Low

SMBus Table: SS Readback and Control Register

Byte 1	Name	Control Function	Type	0	1	Default
Bit 7	SSENRB1	SS Enable Readback Bit1	R	00' for SS_EN_tri = 0, '01' for SS_EN_tri = 'M', '11 for SS_EN_tri = '1'		Latch
Bit 6	SSENRB1	SS Enable Readback Bit0	R			Latch
Bit 5	SSEN_SWCNTRL	Enable SW control of SS	RW	Values in B1[7:6] control SS amount	Values in B1[4:3] control SS amount.	0
Bit 4	SSENSW1	SS Enable Software Ctl Bit1	RW ¹	00' = SS Off, '01' = -0.25% SS, '10' = Reserved, '11' = -0.5% SS		0
Bit 3	SSENSW0	SS Enable Software Ctl Bit0	RW ¹			0
Bit 2	Reserved					1
Bit 1	AMPLITUDE 1	Controls Output Amplitude	RW	00 = 0.6V	01 = 0.7V	1
Bit 0	AMPLITUDE 0		RW	10 = 0.8V	11 = 0.9V	0

1. B1[5] must be set to a 1 for these bits to have any effect on the part.

SMBus Table: DIF Slew Rate Control Register

Byte 2	Name	Control Function	Type	0	1	Default
Bit 7	SLEWRATESEL DIF7	Adjust Slew Rate of DIF7	RW	Slow Setting	Fast Setting	1
Bit 6	SLEWRATESEL DIF6	Adjust Slew Rate of DIF6	RW	Slow Setting	Fast Setting	1
Bit 5	SLEWRATESEL DIF5	Adjust Slew Rate of DIF5	RW	Slow Setting	Fast Setting	1
Bit 4	SLEWRATESEL DIF4	Adjust Slew Rate of DIF4	RW	Slow Setting	Fast Setting	1
Bit 3	SLEWRATESEL DIF3	Adjust Slew Rate of DIF3	RW	Slow Setting	Fast Setting	1
Bit 2	SLEWRATESEL DIF2	Adjust Slew Rate of DIF2	RW	Slow Setting	Fast Setting	1
Bit 1	SLEWRATESEL DIF1	Adjust Slew Rate of DIF1	RW	Slow Setting	Fast Setting	1
Bit 0	SLEWRATESEL DIF0	Adjust Slew Rate of DIF0	RW	Slow Setting	Fast Setting	1

SMBus Table: Nominal Vhigh Amplitude Control/ REF Control Register

Byte 3	Name	Control Function	Type	0	1	Default
Bit 7	REF	Slew Rate Control	RW	00 = Slowest	01 = Slow	0
Bit 6			RW	10 = Fast	11 = Faster	1
Bit 5	REF Power Down Function	Wake-on-Lan Enable for REF	RW	REF does not run in Power Down	REF runs in Power Down	0
Bit 4	REF OE	REF Output Enable	RW	Low	Enabled	1
Bit 3	Reserved					1
Bit 2	Reserved					1
Bit 1	Reserved					1
Bit 0	Reserved					1

Byte 4 is Reserved

SMBus Table: Revision and Vendor ID Register

Byte 5	Name	Control Function	Type	0	1	Default
Bit 7	RID3	Revision ID	R	C rev = 0001		0
Bit 6	RID2		R			0
Bit 5	RID1		R			0
Bit 4	RID0		R			1
Bit 3	VID3	VENDOR ID	R	0001 = IDT		0
Bit 2	VID2		R			0
Bit 1	VID1		R			0
Bit 0	VID0		R			1

SMBus Table: Device Type/Device ID

Byte 6	Name	Control Function	Type	0	1	Default
Bit 7	Device Type1	Device Type	R	00 = FGx, 01 = DBx ZDB/FOB, 10 = DMx, 11= DBx FOB		0
Bit 6	Device Type0		R			0
Bit 5	Device ID5	Device ID	R	001000 binary or 08 hex		0
Bit 4	Device ID4		R			0
Bit 3	Device ID3		R			1
Bit 2	Device ID2		R			0
Bit 1	Device ID1		R			0
Bit 0	Device ID0		R			0

SMBus Table: Byte Count Register

Byte 7	Name	Control Function	Type	0	1	Default
Bit 7		Reserved				0
Bit 6		Reserved				0
Bit 5		Reserved				0
Bit 4	BC4	Byte Count Programming	RW	Writing to this register will configure how many bytes will be read back, default is = 8 bytes.		0
Bit 3	BC3		RW			1
Bit 2	BC2		RW			0
Bit 1	BC1		RW			0
Bit 0	BC0		RW			0
			RW			0

Recommended Crystal Characteristics (3225 package)

PARAMETER	VALUE	UNITS	NOTES
Frequency	25	MHz	1
Resonance Mode	Fundamental	-	1
Frequency Tolerance @ 25°C	±20	PPM Max	1
Frequency Stability, ref @ 25°C Over Operating Temperature Range	±20	PPM Max	1
Temperature Range (commercial)	0~70	°C	1
Temperature Range (industrial)	-40~85	°C	2
Equivalent Series Resistance (ESR)	50	Ω Max	1
Shunt Capacitance (C _O)	7	pF Max	1
Load Capacitance (C _L)	8	pF Max	1
Drive Level	0.3	mW Max	1
Aging per year	±5	PPM Max	1

Notes:

1. FOX 603-25-150.
2. For I-temp, FOX 603-25-261.

Thermal Characteristics

PARAMETER	SYMBOL	CONDITIONS	PKG	TYP.	UNITS	NOTES
Thermal Resistance	θ_{JC}	Junction to Case	NDG48	33	°C/W	1
	θ_{Jb}	Junction to Base		2.1	°C/W	1
	θ_{JA0}	Junction to Air, still air		37	°C/W	1
	θ_{JA1}	Junction to Air, 1 m/s air flow		30	°C/W	1
	θ_{JA3}	Junction to Air, 3 m/s air flow		27	°C/W	1
	θ_{JA5}	Junction to Air, 5 m/s air flow		26	°C/W	1

¹ePad soldered to board

Marking Diagrams

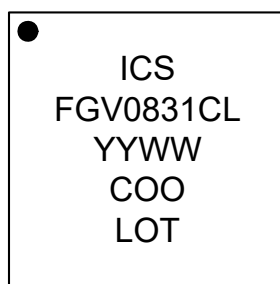
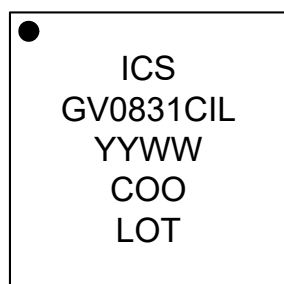

Notes:

1. Line 2 is the truncated part number.
2. "L" denotes RoHS compliant package.
3. "I" denotes industrial temperature grade.
4. "YYWW" is the last two digits of the year and week that the part was assembled.
5. "COO" denotes country of origin.
6. "LOT" is the lot number.

Package Outline Drawings

The package outline drawings are appended at the end of this document and are accessible from the link below. The package information is the most current data available.

www.idt.com/document/psc/48-vfqfpn-package-outline-drawing-60-x-60-x-090-mm-body-epad-41-x-41-mm-040mm-pitch-ndg48p1

Ordering Information

Part / Order Number	Shipping Packaging	Package	Temperature
9FGV0831CKLF	Trays	48-pin VFQFPN	0 to +70° C
9FGV0831CKLFT	Tape and Reel	48-pin VFQFPN	0 to +70° C
9FGV0831CKILF	Trays	48-pin VFQFPN	-40 to +85° C
9FGV0831CKILFT	Tape and Reel	48-pin VFQFPN	-40 to +85° C

“LF” suffix to the part number are the Pb-Free configuration and are RoHS compliant.

“C” is the device revision designator (will not correlate with the datasheet revision).

Revision History

Revision Date	Description
September 29, 2014	<ol style="list-style-type: none"> Updated front page text and block diagram. Updated pin out to remove references to VDD Suspend pins. Using the part with collapsible power supplies did not save power and complicated board design. NO pins were changed. Updated SMBus Descriptions Simplified footnote 2 on PPM table. Updated all electrical tables to latest format.
November 25, 2015	<ol style="list-style-type: none"> Updated POD with latest document
October 18, 2016	Removed IDT crystal part number
June 26, 2017	<ol style="list-style-type: none"> Updated front page Gendes to reflect the PCIe Gen4 updates. Updated Electrical Characteristics - Filtered Phase Jitter Parameters - PCIe Common Clocked (CC) Architectures and added PCIe Gen4 Data
May 13, 2019	Updated package outline drawings.
June 6, 2019	Changed Input Current minimum and maximum values from -200/200uA to -20/20uA.

IMPORTANT NOTICE AND DISCLAIMER

RENESAS ELECTRONICS CORPORATION AND ITS SUBSIDIARIES (“RENESAS”) PROVIDES TECHNICAL SPECIFICATIONS AND RELIABILITY DATA (INCLUDING DATASHEETS), DESIGN RESOURCES (INCLUDING REFERENCE DESIGNS), APPLICATION OR OTHER DESIGN ADVICE, WEB TOOLS, SAFETY INFORMATION, AND OTHER RESOURCES “AS IS” AND WITH ALL FAULTS, AND DISCLAIMS ALL WARRANTIES, EXPRESS OR IMPLIED, INCLUDING, WITHOUT LIMITATION, ANY IMPLIED WARRANTIES OF MERCHANTABILITY, FITNESS FOR A PARTICULAR PURPOSE, OR NON-INFRINGEMENT OF THIRD-PARTY INTELLECTUAL PROPERTY RIGHTS.

These resources are intended for developers who are designing with Renesas products. You are solely responsible for (1) selecting the appropriate products for your application, (2) designing, validating, and testing your application, and (3) ensuring your application meets applicable standards, and any other safety, security, or other requirements. These resources are subject to change without notice. Renesas grants you permission to use these resources only to develop an application that uses Renesas products. Other reproduction or use of these resources is strictly prohibited. No license is granted to any other Renesas intellectual property or to any third-party intellectual property. Renesas disclaims responsibility for, and you will fully indemnify Renesas and its representatives against, any claims, damages, costs, losses, or liabilities arising from your use of these resources. Renesas' products are provided only subject to Renesas' Terms and Conditions of Sale or other applicable terms agreed to in writing. No use of any Renesas resources expands or otherwise alters any applicable warranties or warranty disclaimers for these products.

(Disclaimer Rev.1.01 Jan 2024)

Corporate Headquarters

TOYOSU FORESIA, 3-2-24 Toyosu,
Koto-ku, Tokyo 135-0061, Japan
www.renesas.com

Trademarks

Renesas and the Renesas logo are trademarks of Renesas Electronics Corporation. All trademarks and registered trademarks are the property of their respective owners.

Contact Information

For further information on a product, technology, the most up-to-date version of a document, or your nearest sales office, please visit www.renesas.com/contact-us/.

Looking for pricing, stock, or lifecycle information?

Click below to explore more details on WIN SOURCE:

-  [View 9FGV0831CKILFT on WIN SOURCE](#)
-  [Renesas Electronics America](#) Information

Optimize Your Supply Chain with WIN SOURCE Solutions

-  Global Sourcing Solution
-  Obsolete Management
-  Cost Control Management
-  Shortage Management
-  Alternative Solution
-  Excess Inventory Management