



# THE DATASHEET OF BAS70TW-7



## Product Summary

$V_R$ (V)	$I_F$ (mA)	$V_{F\text{ MAX}}$ (V) @ +25°C	$I_{R\text{ MAX}}$ (μA) @ +25°C
70	1.0	0.41	0.10

## Description and Applications

This Schottky Barrier Arrays is designed with low leakage performance in a variety of configurations. This reduces component placement costs by requiring only one component. Designed to meet AEC-Q101 requirements. Configurations are ideally suited to use as:

- Polarity protection diodes
- Rail-to-rail data line protection for two data lines
- Multiplexing circuits
- High-efficiency, low-current bridge rectifier circuits
- Re-circulating diodes
- Switching diodes

SOT363 (Standard)



Top View

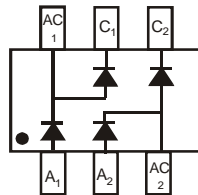

BAS70BRW

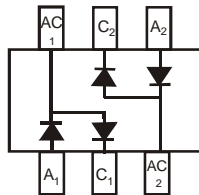

BAS70DW-04\*

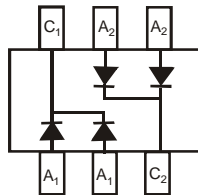

BAS70DW-05\*

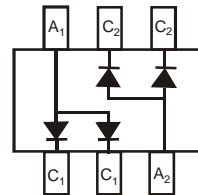

BAS70DW-06\*

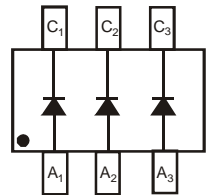

BAS70TW

\*Symmetrical configuration, no orientation indicator.

## Features

- Low Forward Voltage Drop
- Fast Switching
- Ultra-Small Surface Mount Package
- PN Junction Guard Ring for Transient and ESD Protection
- **Totally Lead-Free & Fully RoHS Compliant (Notes 1 & 2)**
- **Halogen and Antimony Free. "Green" Device (Note 3)**
- **The DIODES™ BAS70DW-05Q is suitable for automotive applications requiring specific change control; this part is AEC-Q101 qualified, PPAP capable, and manufactured in IATF 16949 certified facilities.**  
<https://www.diodes.com/quality/product-definitions/>
- **An Automotive-Compliant Part is Available Under Separate Datasheet ([BAS70TWQ](#) [BAS70DW-04Q](#))**

## Mechanical Data

- Package: SOT363
- Package Material: Molded Plastic. UL Flammability Classification Rating 94V-0
- Moisture Sensitivity: Level 1 per J-STD-020
- Terminals: Finish – Matte Tin Plated Leads, Solderable per MIL-STD-202, Method 208 (e3)
- Orientation: See Diagrams Below
- Weight: 0.006 grams (Approximate)

## Ordering Information (Notes 4 & 5)

Part Number	Package	Packing	
		Qty.	Carrier
BAS70DW-04-7-F	SOT363 (Standard)	3000	Tape & Reel
BAS70DW-04-13-F	SOT363 (Standard)	10000	Tape & Reel
BAS70DW-05-7-F	SOT363 (Standard)	3000	Tape & Reel
BAS70DW-05Q-7-F	SOT363 (Standard)	3000	Tape & Reel
BAS70DW-06-7-F	SOT363 (Standard)	3000	Tape & Reel
BAS70BRW-7-F	SOT363 (Standard)	3000	Tape & Reel
BAS70TW-7-F	SOT363 (Standard)	3000	Tape & Reel
BAS70TW-13-F	SOT363 (Standard)	10000	Tape & Reel

- Notes:
1. No purposely added lead. Fully EU Directive 2002/95/EC (RoHS), 2011/65/EU (RoHS 2) & 2015/863/EU (RoHS 3) compliant.
  2. See <https://www.diodes.com/quality/lead-free/> for more information about Diodes Incorporated's definitions of Halogen- and Antimony-free, "Green" and Lead-free.
  3. Halogen- and Antimony-free "Green" products are defined as those which contain <900ppm bromine, <900ppm chlorine (<1500ppm total Br + Cl) and <1000ppm antimony compounds.
  4. Product manufactured with Date Code UO (week 40, 2007) and newer are built with Green Molding Compound. Products manufactured prior to Date Code UO are built with Non-Green Molding Compound and may contain Halogens or Sb2O3 Fire Retardants.
  5. For packaging details, go to our website at <https://www.diodes.com/design/support/packaging/diodes-packaging/>.

## Marking Information

Part Number	Marking Information	
BAS70BRW-7-F BAS70TW-7-F BAS70TW-13-F		<p>Kxx = Product Type Marking Code                      K75 = BAS70BRW                      K73 = BAS70TW                      YM &amp; ȲM = Date Code Marking                      Y &amp; Ȳ = Year (ex: J = 2022)                      M = Month (ex: 9 = September)</p>
BAS70DW-04-7-F BAS70DW-04-13-F BAS70DW-05-7-F BAS70DW-05Q-7-F BAS70DW-06-7-F		<p>Kxx = Product Type Marking Code                      K74 = BAS70DW-04                      K71 = BAS70DW-05                      K76 = BAS70DW-06                      YM &amp; ȲM = Date Code Marking                      Y &amp; Ȳ = Year (ex: J = 2022)                      M = Month (ex: 9 = September)</p>

### Date Code Key

<b>Year</b>	<b>2002</b>	...	<b>2022</b>	<b>2023</b>	<b>2024</b>	<b>2025</b>	<b>2026</b>	<b>2027</b>	<b>2028</b>	<b>2029</b>	<b>2030</b>	<b>2031</b>
<b>Code</b>	O	...	J	K	L	M	N	O	P	R	S	T
<b>Month</b>	<b>Jan</b>	<b>Feb</b>	<b>Mar</b>	<b>Apr</b>	<b>May</b>	<b>Jun</b>	<b>Jul</b>	<b>Aug</b>	<b>Sep</b>	<b>Oct</b>	<b>Nov</b>	<b>Dec</b>
<b>Code</b>	1	2	3	4	5	6	7	8	9	O	N	D

## Maximum Ratings (@T<sub>A</sub> = +25°C, unless otherwise specified.)

Characteristic	Symbol	Value	Unit
Peak Repetitive Reverse Voltage	V <sub>RRM</sub>	70	V
Working Peak Reverse Voltage	V <sub>RWM</sub>		
DC Blocking Voltage	V <sub>R</sub>		
RMS Reverse Voltage	V <sub>R(RMS)</sub>	49	V
Forward Continuous Current (Note 6)	I <sub>FM</sub>	70	mA
Non-Repetitive Peak Forward Surge Current	I <sub>FSM</sub>	100	mA
		@ t < 1.0s	

## Thermal Characteristics

Characteristic	Symbol	Value	Unit
Power Dissipation (Note 7)	P <sub>D</sub>	200	mW
Thermal Resistance Junction to Ambient Air (Note 7)	R <sub>θJA</sub>	625	°C/W
Operating and Storage Temperature Range	T <sub>J</sub>	-55 to +125	°C
	T <sub>STG</sub>	-65 to +125	

## Electrical Characteristics (@T<sub>A</sub> = +25°C, unless otherwise specified.)

Characteristic	Symbol	Min	Max	Unit	Test Condition
Reverse Breakdown Voltage (Note 6)	V <sub>(BR)R</sub>	70	—	V	I <sub>R</sub> = 10μA
Forward Voltage	V <sub>F</sub>	—	410	mV	t <sub>p</sub> < 300μs, I <sub>F</sub> = 1.0mA
			1000	mV	t <sub>p</sub> < 300μs, I <sub>F</sub> = 15mA
Reverse Current (Note 6)	I <sub>R</sub>	—	100	nA	t <sub>p</sub> < 300μs, V <sub>R</sub> = 50V
Total Capacitance	C <sub>T</sub>	—	2.0	pF	V <sub>R</sub> = 0V, f = 1.0MHz
Reverse Recovery Time	t <sub>RR</sub>	—	5.0	ns	I <sub>F</sub> = I <sub>R</sub> = 10mA to I <sub>R</sub> = 1.0mA, I <sub>RR</sub> = 0.1 x I <sub>R</sub> , R <sub>L</sub> = 100Ω

Notes:

6. Short duration pulse test used to minimize self-heating effect.

7. Part mounted on FR-4 board with recommended pad layout, which can be found on our website at <http://www.diodes.com/package-outlines.html>.

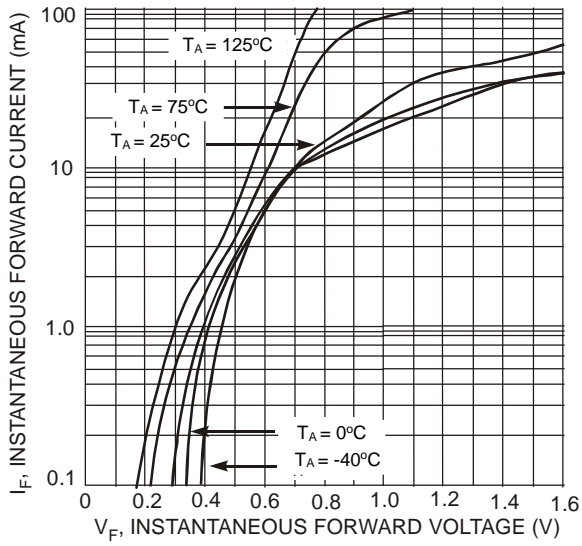

Fig. 1 Typical Forward Characteristics

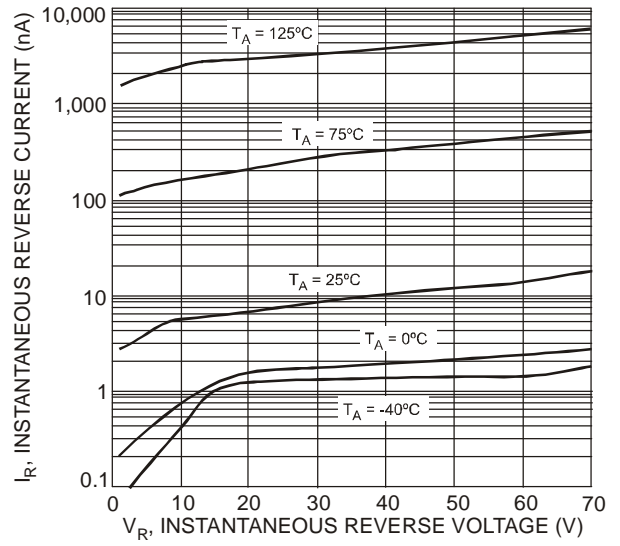

Fig. 2 Typical Reverse Characteristics

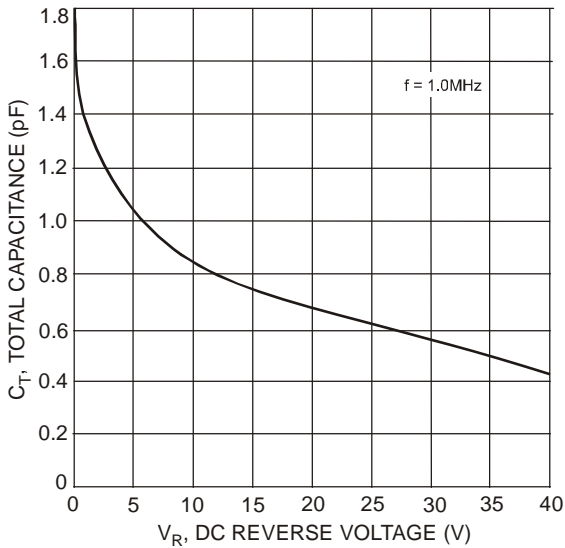

Fig. 3 Total Capacitance vs. Reverse Voltage

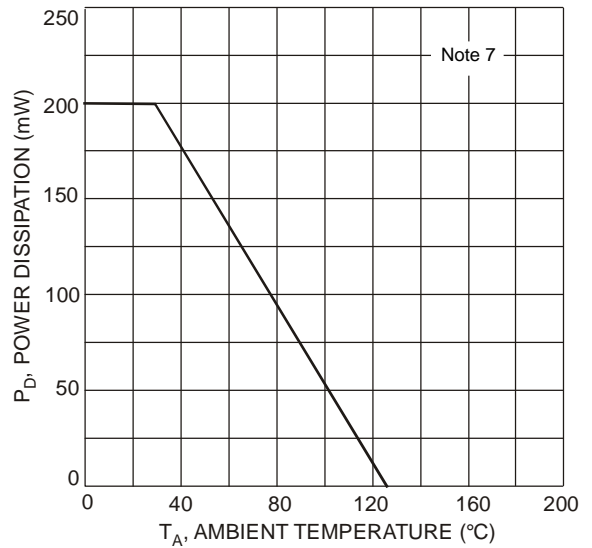
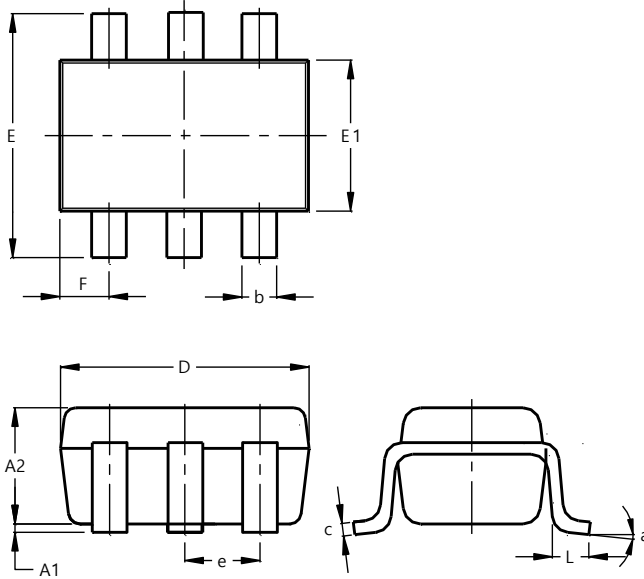

Fig. 4 Power Derating Curve, Total Package

**Package Outline Dimensions**

Please see <http://www.diodes.com/package-outlines.html> for the latest version.

**SOT363 (Standard)**



SOT363 (Standard)			
Dim	Min	Max	Typ
A1	0.00	0.10	0.05
A2	0.80	1.00	0.90
b	0.10	0.35	0.225
c	0.08	0.22	0.15
D	1.80	2.20	2.00
E	2.00	2.45	2.225
E1	1.15	1.35	1.25
e	--	--	0.65
F	0.25	0.45	0.35
L	0.25	0.46	0.355
a	0°	8°	--
All Dimensions in mm			

**Suggested Pad Layout**

Please see <http://www.diodes.com/package-outlines.html> for the latest version.

**SOT363 (Standard)**

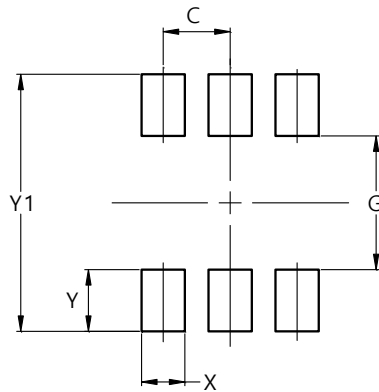

Dimensions	Value (in mm)
C	0.650
G	1.300
X	0.420
Y	0.600
Y1	2.500

**IMPORTANT NOTICE**



1. DIODES INCORPORATED (Diodes) AND ITS SUBSIDIARIES MAKE NO WARRANTY OF ANY KIND, EXPRESS OR IMPLIED, WITH REGARDS TO ANY INFORMATION CONTAINED IN THIS DOCUMENT, INCLUDING, BUT NOT LIMITED TO, THE IMPLIED WARRANTIES OF MERCHANTABILITY, FITNESS FOR A PARTICULAR PURPOSE OR NON-INFRINGEMENT OF THIRD PARTY INTELLECTUAL PROPERTY RIGHTS (AND THEIR EQUIVALENTS UNDER THE LAWS OF ANY JURISDICTION).
2. The Information contained herein is for informational purpose only and is provided only to illustrate the operation of Diodes' products described herein and application examples. Diodes does not assume any liability arising out of the application or use of this document or any product described herein. This document is intended for skilled and technically trained engineering customers and users who design with Diodes' products. Diodes' products may be used to facilitate safety-related applications; however, in all instances customers and users are responsible for (a) selecting the appropriate Diodes products for their applications, (b) evaluating the suitability of Diodes' products for their intended applications, (c) ensuring their applications, which incorporate Diodes' products, comply the applicable legal and regulatory requirements as well as safety and functional-safety related standards, and (d) ensuring they design with appropriate safeguards (including testing, validation, quality control techniques, redundancy, malfunction prevention, and appropriate treatment for aging degradation) to minimize the risks associated with their applications.
3. Diodes assumes no liability for any application-related information, support, assistance or feedback that may be provided by Diodes from time to time. Any customer or user of this document or products described herein will assume all risks and liabilities associated with such use, and will hold Diodes and all companies whose products are represented herein or on Diodes' websites, harmless against all damages and liabilities.
4. Products described herein may be covered by one or more United States, international or foreign patents and pending patent applications. Product names and markings noted herein may also be covered by one or more United States, international or foreign trademarks and trademark applications. Diodes does not convey any license under any of its intellectual property rights or the rights of any third parties (including third parties whose products and services may be described in this document or on Diodes' website) under this document.
5. Diodes' products are provided subject to Diodes' Standard Terms and Conditions of Sale (<https://www.diodes.com/about/company/terms-and-conditions/terms-and-conditions-of-sales/>) or other applicable terms. This document does not alter or expand the applicable warranties provided by Diodes. Diodes does not warrant or accept any liability whatsoever in respect of any products purchased through unauthorized sales channel.
6. Diodes' products and technology may not be used for or incorporated into any products or systems whose manufacture, use or sale is prohibited under any applicable laws and regulations. Should customers or users use Diodes' products in contravention of any applicable laws or regulations, or for any unintended or unauthorized application, customers and users will (a) be solely responsible for any damages, losses or penalties arising in connection therewith or as a result thereof, and (b) indemnify and hold Diodes and its representatives and agents harmless against any and all claims, damages, expenses, and attorney fees arising out of, directly or indirectly, any claim relating to any noncompliance with the applicable laws and regulations, as well as any unintended or unauthorized application.
7. While efforts have been made to ensure the information contained in this document is accurate, complete and current, it may contain technical inaccuracies, omissions and typographical errors. Diodes does not warrant that information contained in this document is error-free and Diodes is under no obligation to update or otherwise correct this information. Notwithstanding the foregoing, Diodes reserves the right to make modifications, enhancements, improvements, corrections or other changes without further notice to this document and any product described herein. This document is written in English but may be translated into multiple languages for reference. Only the English version of this document is the final and determinative format released by Diodes.
8. Any unauthorized copying, modification, distribution, transmission, display or other use of this document (or any portion hereof) is prohibited. Diodes assumes no responsibility for any losses incurred by the customers or users or any third parties arising from any such unauthorized use.
9. This Notice may be periodically updated with the most recent version available at <https://www.diodes.com/about/company/terms-and-conditions/important-notice>

DIODES is a trademark of Diodes Incorporated in the United States and other countries.  
The Diodes logo is a registered trademark of Diodes Incorporated in the United States and other countries.  
© 2022 Diodes Incorporated. All Rights Reserved.

[www.diodes.com](http://www.diodes.com)

## Looking for pricing, stock, or lifecycle information?

Click below to explore more details on WIN SOURCE:

-  [View BAS70TW-7 on WIN SOURCE](#)
-  [Diodes Incorporated Information](#)

## Optimize Your Supply Chain with WIN SOURCE Solutions

-  Global Sourcing Solution
-  Obsolete Management
-  Cost Control Management
-  Shortage Management
-  Alternative Solution
-  Excess Inventory Management