



**THE DATASHEET OF
MM126526**



SPECIFICATION

1. MECHANICAL

Automatic measurement probe for SWH-2WAY(MM8930-2620) to measure RF side performance.

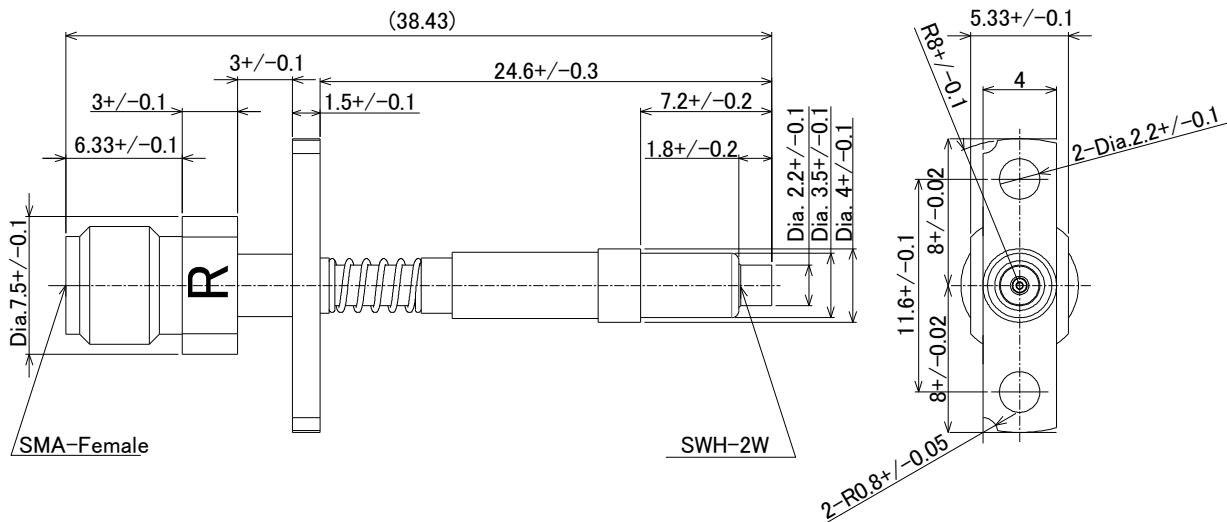

Scale: Free
 Tolerance Unless
 Otherwise Specified: +/- 0.5
 Unit: mm

Figure 1 Construction

2. RATING:

Item	Specification
Voltage Rating	30Vr.m.s. maximum
Nominal Frequency Range	DC to 6GHz
Nominal Impedance	50Ω
Temperature Rating	-40°C to +85°C
Insulation Resistance	500 MΩ minimum
Withstanding Voltage	No evidence of breakdown AC200Vr.m.s, 1minute
Initial Contact Resistance (without conductor resistance)	70.0mΩmax.
A > Voltage Standing Wave Ratio (V.S.W.R.)	2.1 max.(DC · 3GHz) 2.2 max.(3GHz · 6GHz)
A > Insertion loss	0.8 dB max.(DC · 3GHz) 0.8 dB max.(3GHz · 6GHz)
Durability	1M cycles

3. USE THIS PRODUCTS

3.1 The directions for attachment to measurement machine.

The probe must be attached to machine at the two screw holes in probe flange. (Figure 2)

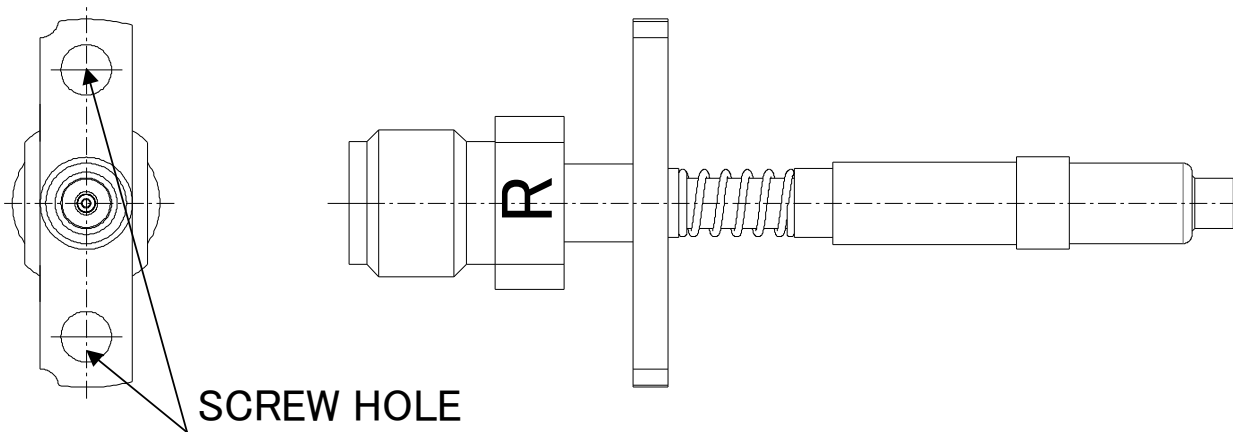

Figure.2 Screw hole position

3.2 The tolerance of position against MM8930-2620.

3.2.1 Probe has the centering function by itself, $\pm 0.5\text{mm}$ is permitted against the hole center of MM8930-2620.

Please avoid needless force to SMA connector to come back the original position when disengagement of probe. To avoid the needless force, we recommend using extension cable assembly, MXHR87HR3000. The instruction of the MXHR87HR3000 is as Figure 3.

There is the possibility, following function $\pm 0.5\text{mm}$ is not permitted against the hole center of MM8930-2620, when probe effects the needless force.

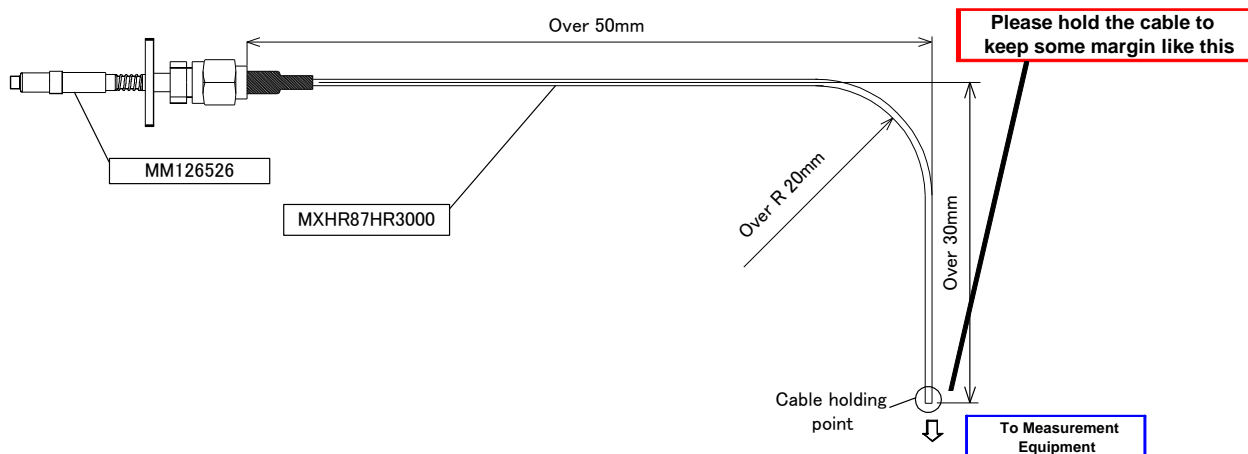
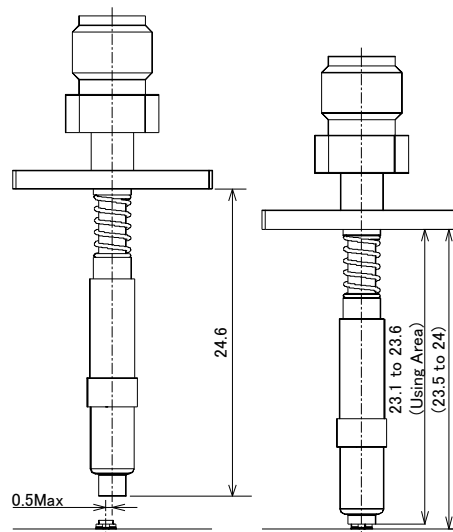

Figure.3 Instruction of MXHR87HR3000

3.2.2 To get the 15dB or higher isolation (up to 6GHz), The engagement strokes from the flange to the tip of probe is **23.1mm to 23.6mm**. (Figure 4)



UNIT: mm

Figure.4 Acceptable engagement range to MM8930-2620

3.3 The machine's hole diameter for attachment probe.

To accept +/-0.5mm against the hole center of MM8930-2620, please design the machine by Figure 5.

To distinguish Antenna measurement probe from RF measurement probe by flange design, please design the positioning pin by Figure 5.

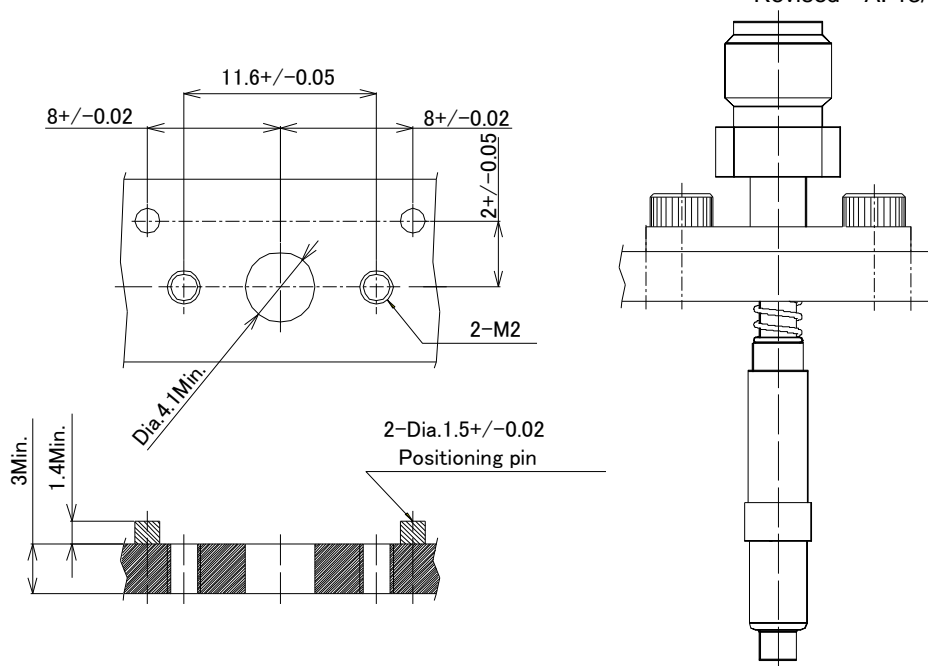

UNIT: mm

Figure.5 Machine's hole diameter for attachment probe

- 3.4 The slant angle tolerance of probe against MM8930-2620. (Figure 6)
 To have the stable measurement, MM126526 slant angle must be ± 2 degree.

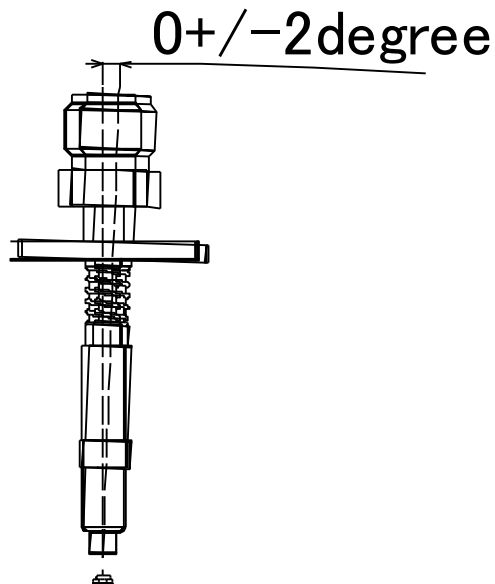

Figure.6 Probe Shape Operation Manual for Auto Measurement probe (MM126526)

4. CAUTION

Limitation of Applications

Please do not use our products for the applications listed below which require specially high reliability for the prevention of defects which may directly or indirectly cause damage to the third party's life, body or property.



Preliminary Specification of COAXIAL CONNECTOR
Preliminary SPEC No. : NMM04-PU0046A
Part Number : MM126526

Written by H. Matsukawa
Checked by M. Atokawa
Date 04/Jul./2014
Revised A: 13/May./'15 KA

- (1) Aircraft equipment
- (2) Aerospace equipment
- (3) Undersea equipment
- (4) Power plant control equipment
- (5) Medical equipment
- (6) Transportation equipment (vehicles, trains, ships, etc.)
- (7) Traffic signal equipment
- (8) Disaster prevention / crime prevention equipment
- (9) Data-processing equipment
- (10) Application of similar complexity and/or reliability requirements to the applications listed in the above.

Looking for pricing, stock, or lifecycle information?

Click below to explore more details on WIN SOURCE:

- [View MM126526 on WIN SOURCE](#)
- [Murata Electronics North America Information](#)

Optimize Your Supply Chain with WIN SOURCE Solutions

- ✓ Global Sourcing Solution
- ✓ Obsolete Management
- ✓ Cost Control Management
- ✓ Shortage Management
- ✓ Alternative Solution
- ✓ Excess Inventory Management