



**THE DATASHEET OF
SN74HCT165QPWRQ1**



SN74HCT165-Q1 Automotive 8-Bit Parallel-Load Shift Registers

1 Features

- AEC-Q100 qualified for automotive applications:
 - Device temperature grade 1:
 - -40°C to $+125^{\circ}\text{C}$, T_A
 - Device HBM ESD Classification Level 2
 - Device CDM ESD Classification Level C6
- LSTTL input logic compatible
 - $V_{IL(max)} = 0.8\text{ V}$, $V_{IH(min)} = 2\text{ V}$
- CMOS input logic compatible
 - $I_I \leq 1\ \mu\text{A}$ at V_{OL} , V_{OH}
- 4.5 V to 5.5 V operation
- Supports fanout up to 10 LSTTL loads
- Direct overriding load (data) inputs
- Gated clock inputs

2 Applications

- [Increase the number of inputs on a microcontroller](#)

3 Description

The SN74HCT165-Q1 is a parallel- or serial-in, serial-out 8-bit shift register. Parallel-in access to each stage is provided by eight individual direct data (A-H) inputs that are enabled by a low level at the shift/load (SH/LD) input. The SN74HCT165-Q1 also features a clock-inhibit (CLK INH) function and a complementary serial (\bar{Q}_H) output.

Device Information

PART NUMBER	PACKAGE ⁽¹⁾	BODY SIZE (NOM)
SN74HCT165PW-Q1	TSSOP (16)	5.00 mm × 4.40 mm

- (1) For all available packages, see the orderable addendum at the end of the data sheet.

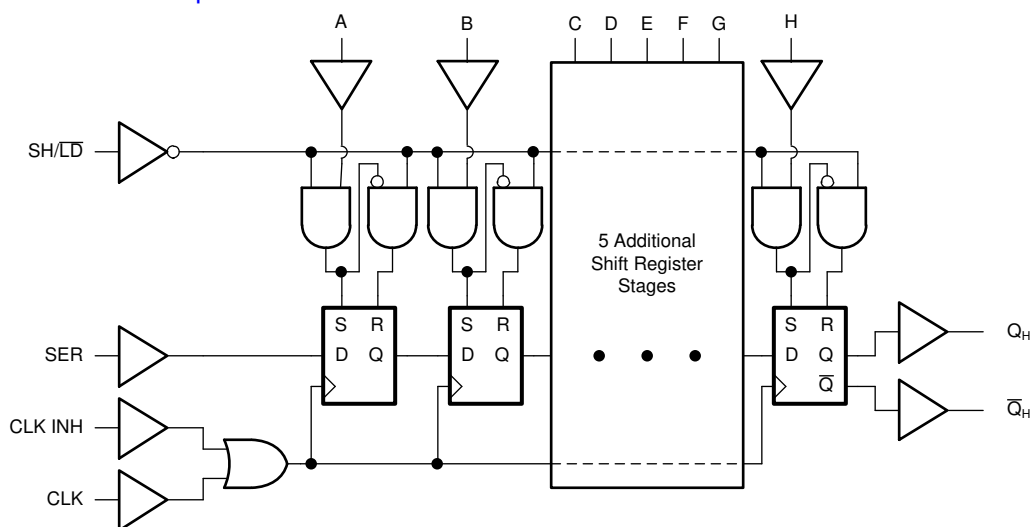

Positive Logic Diagram



Table of Contents

1 Features	1	8.3 Feature Description.....	10
2 Applications	1	8.4 Device Functional Modes.....	11
3 Description	1	9 Application and Implementation	12
4 Revision History	2	9.1 Application Information.....	12
5 Pin Configuration and Functions	3	9.2 Typical Application.....	12
6 Specifications	4	10 Power Supply Recommendations	15
6.1 Absolute Maximum Ratings.....	4	11 Layout	15
6.2 ESD Ratings.....	4	11.1 Layout Guidelines.....	15
6.3 Recommended Operating Conditions.....	4	11.2 Layout Example.....	15
6.4 Thermal Information.....	4	12 Device and Documentation Support	16
6.5 Electrical Characteristics.....	5	12.1 Documentation Support.....	16
6.6 Timing Characteristics.....	5	12.2 Receiving Notification of Documentation Updates..	16
6.7 Switching Characteristics.....	6	12.3 Support Resources.....	16
6.8 Typical Characteristics.....	7	12.4 Trademarks.....	16
7 Parameter Measurement Information	8	12.5 Electrostatic Discharge Caution.....	16
8 Detailed Description	9	12.6 Glossary.....	16
8.1 Overview.....	9	13 Mechanical, Packaging, and Orderable	
8.2 Functional Block Diagram.....	9	Information	16

4 Revision History

NOTE: Page numbers for previous revisions may differ from page numbers in the current version.

Changes from Revision * (October 2021) to Revision A (December 2021)	Page
• Updated the status of the data sheet from: <i>Advanced Information</i> to: <i>Production Data</i>	1

5 Pin Configuration and Functions

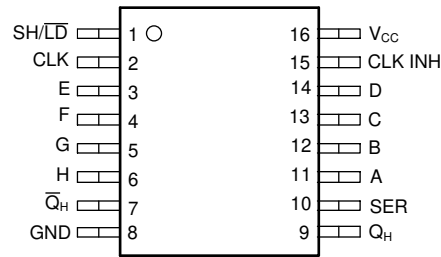

**Figure 5-1. PW Package
16-Pin TSSOP
Top View**

Table 5-1. Pin Functions

PIN		TYPE ⁽¹⁾	DESCRIPTION
NAME	NO.		
SH/LD	1	I	Enable shifting when input is high, load data when input is low
CLK	2	I	Clock, rising edge triggered
E	3	I	Parallel input E
F	4	I	Parallel input F
G	5	I	Parallel input G
H	6	I	Parallel input H
\bar{Q}_H	7	O	Inverted serial output
GND	8	—	Ground
Q_H	9	O	Serial output
SER	10	I	Serial input
A	11	I	Parallel input A
B	12	I	Parallel input B
C	13	I	Parallel input C
D	14	I	Parallel input D
CLK INH	15	I	Clock inhibit input
V _{CC}	16	—	Positive supply

(1) Signal Types: I = Input, O = Output, I/O = Input or Output.

6 Specifications

6.1 Absolute Maximum Ratings

over operating free-air temperature range (unless otherwise noted)⁽¹⁾

		MIN	MAX	UNIT
V_{CC}	Supply voltage	-0.5	7	V
I_{IK}	Input clamp current ⁽²⁾	$V_I < 0$ or $V_I > V_{CC} + 0.5$ V		mA
I_{OK}	Output clamp current ⁽²⁾	$V_O < 0$ or $V_O > V_{CC} + 0.5$ V		mA
I_O	Continuous output current	$V_O = 0$ to V_{CC}		mA
I_{CC}	Continuous output current through V_{CC} or GND	-70	70	mA
T_J	Junction temperature		150	°C
T_{stg}	Storage temperature	-65	150	°C

- (1) Operation outside the *Absolute Maximum Ratings* may cause permanent device damage. Absolute maximum ratings do not imply functional operation of the device at these or any other conditions beyond those listed under *Recommended Operating Conditions*. If briefly operating outside the *Recommended Operating Conditions* but within the *Absolute Maximum Ratings*, the device may not sustain damage, but it may not be fully functional. Operating the device in this manner may affect device reliability, functionality, performance, and shorten the device lifetime.
- (2) The input and output voltage ratings may be exceeded if the input and output current ratings are observed.

6.2 ESD Ratings

		VALUE	UNIT
$V_{(ESD)}$	Electrostatic discharge	Human body model (HBM), per AEC Q100-002 ⁽¹⁾ HBM ESD Classification Level 2	±4000
		Charged device model (CDM), per AEC Q100-011 CDM ESD Classification Level C4B	±1500

- (1) AEC Q100-002 indicate that HBM stressing shall be in accordance with the ANSI/ESDA/JEDEC JS-001 specification.

6.3 Recommended Operating Conditions

over operating free-air temperature range (unless otherwise noted)

		MIN	NOM	MAX	UNIT
V_{CC}	Supply voltage	4.5	5	5.5	V
V_{IH}	High-level input voltage	$V_{CC} = 4.5$ V to 5.5 V		2	V
V_{IL}	Low-level input voltage	$V_{CC} = 4.5$ V to 5.5 V		0.8	V
V_I	Input voltage	0		V_{CC}	V
V_O	Output voltage	0		V_{CC}	V
$\Delta t/\Delta v$	Input transition rise and fall rate	$V_{CC} = 4.5$ V to 5.5 V		500	ns/V
T_A	Ambient temperature	-40		125	°C

6.4 Thermal Information

THERMAL METRIC ⁽¹⁾		SN74HCT165-Q1	UNIT
		PW (TSSOP)	
		16 PINS	
$R_{\theta JA}$	Junction-to-ambient thermal resistance	131.8	°C/W
$R_{\theta JC(top)}$	Junction-to-case (top) thermal resistance	69.8	°C/W
$R_{\theta JB}$	Junction-to-board thermal resistance	76.5	°C/W
Ψ_{JT}	Junction-to-top characterization parameter	20.9	°C/W
Υ_{JB}	Junction-to-board characterization parameter	76.1	°C/W

6.4 Thermal Information (continued)

THERMAL METRIC ⁽¹⁾		SN74HCT165-Q1		
		PW (TSSOP)		
		16 PINS		
$R_{\theta JC(bot)}$	Junction-to-case (bottom) thermal resistance	N/A		°C/W

(1) For more information about traditional and new thermal metrics, see the [Semiconductor and IC Package Thermal Metrics](#) application report.

6.5 Electrical Characteristics

over operating free-air temperature range (unless otherwise noted)

PARAMETER		TEST CONDITIONS		$T_A = 25^\circ\text{C}$			$-40^\circ\text{C to } 125^\circ\text{C}$			UNIT	
				MIN	TYP	MAX	MIN	TYP	MAX		
V_{OH}	High-level output voltage	$V_I = V_{IH}$ or V_{IL}	$I_{OH} = -20 \mu\text{A}, V_{CC} = 4.5 \text{ V}$	4.4			4.4			V	
			$I_{OH} = -4 \text{ mA}, V_{CC} = 4.5 \text{ V}$	3.98			3.84			V	
V_{OL}	Low-level output voltage	$V_I = V_{IH}$ or V_{IL}	$I_{OL} = 20 \mu\text{A}, V_{CC} = 4.5 \text{ V}$				0.1			V	
			$I_{OL} = 4 \text{ mA}, V_{CC} = 4.5 \text{ V}$				0.26			0.33	V
I_I	Input leakage current	$V_I = V_{CC}$ or 0	$V_{CC} = 5.5 \text{ V}$				± 100			± 1000	nA
I_{OZ}	Off-State (High-Impedance State) Output Current	$V_O = V_{CC}$ or 0, Q_A-Q_H	$V_{CC} = 5.5 \text{ V}$				± 0.5			± 5	μA
I_{CC}	Supply current	$V_I = V_{CC}$ or 0, $I_O = 0$	$V_{CC} = 5.5 \text{ V}$				8			80	μA
ΔI_{CC}	Additional Quiescent Device Current Per Input Pin	$V_I = V_{CC} - 2.1 \text{ V}$	$V_{CC} = 4.5 \text{ V to } 5.5 \text{ V}$	126.2			157.5			μA	
		$V_I = 0.5 \text{ V or } 2.4 \text{ V}$	$V_{CC} = 5.5 \text{ V}$	2.4			2.9			mA	
C_i	Input capacitance	$V_{CC} = 4.5 \text{ V to } 5.5 \text{ V}$	$V_{CC} = 4.5 \text{ V to } 5.5 \text{ V}$	10						pF	
C_O	Output capacitance	$V_{CC} = 4.5 \text{ V to } 5.5 \text{ V}$	$V_{CC} = 4.5 \text{ V to } 5.5 \text{ V}$	20						pF	
C_{pd}	Power dissipation capacitance per gate	No load		50						pF	

6.6 Timing Characteristics

over recommended operating free-air temperature range (unless otherwise noted)

PARAMETER		CONDITION	V_{CC}	$T_A = 25^\circ\text{C}$		$-40^\circ\text{C to } 125^\circ\text{C}$		UNIT
				MIN	MAX	MIN	MAX	
f_{clock}	Clock frequency		4.5 V	31		25		MHz
t_w	Pulse duration	SH/LD low	4.5 V	20		25		ns
			5.5 V	20		25		
		CLK high or low	4.5 V	18		23		
			5.5 V	18		23		

6.6 Timing Characteristics (continued)

over recommended operating free-air temperature range (unless otherwise noted)

PARAMETER		CONDITION	V _{CC}	T _A = 25°C		-40°C to 125°C		UNIT
				MIN	MAX	MIN	MAX	
t _{su}	Setup time	SH/LD high before CLK↑	4.5 V	20		25	ns	
			5.5 V	20		25		
		SER before CLK↑	4.5 V	20		25		
			5.5 V	20		25		
		CLK INH low before CLK↑	4.5 V	20		25		
			5.5 V	20		25		
		CLK INH high before CLK↑	4.5 V	20		25		
			5.5 V	20		25		
Data before SH/LD↓	4.5 V	20		25				
	5.5 V	20		25				
t _h	Hold time	Ser data after CLK↑ or CLK INH↑	4.5 V	7		9	ns	
			5.5 V	7		9		
		PAR data after SH/LD↓	4.5 V	7		9		
			5.5 V	7		9		

6.7 Switching Characteristics

over operating free-air temperature range (unless otherwise noted)

PARAMETER		FROM (INPUT)	TO (OUTPUT)	V _{CC}	T _A = 25°C			-40°C to 125°C			UNIT
					MIN	TYP	MAX	MIN	TYP	MAX	
f _{max}				4.5 V	31			25			MHz
t _{pd}	Propagation delay	SH/LD	Q _H or Q _H	4.5 V						60	ns
				5.5 V						60	
		CLK	Q _H or Q _H	4.5 V					40	60	
				5.5 V					40	60	
		H	Q _H or Q _H	4.5 V					35	53	
				5.5 V					35	53	
t _t	Transition-time		Any output	4.5 V					12	15	ns
			Any output	5.5 V					14	17	

6.8 Typical Characteristics

$T_A = 25^\circ\text{C}$

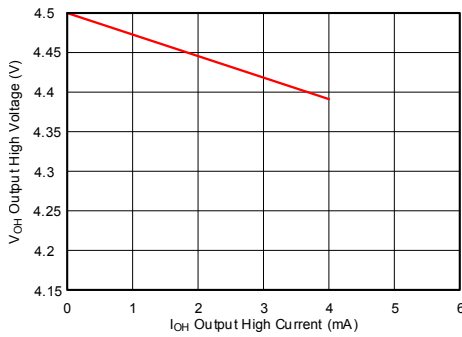

Figure 6-1. Typical Output Voltage in the High State (V_{OH})

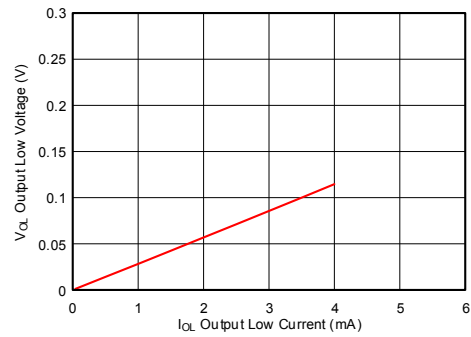

Figure 6-2. Typical Output Voltage in the Low State (V_{OL})

7 Parameter Measurement Information

Phase relationships between waveforms were chosen arbitrarily. All input pulses are supplied by generators having the following characteristics: $PRR \leq 1 \text{ MHz}$, $Z_O = 50 \Omega$, $t_t < 6 \text{ ns}$.

For clock inputs, f_{max} is measured when the input duty cycle is 50%.

The outputs are measured one at a time with one input transition per measurement.

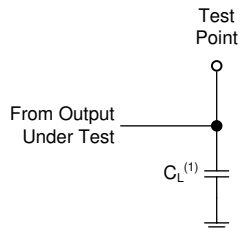

(1) C_L includes probe and test-fixture capacitance.

Figure 7-1. Load Circuit for Push-Pull Outputs

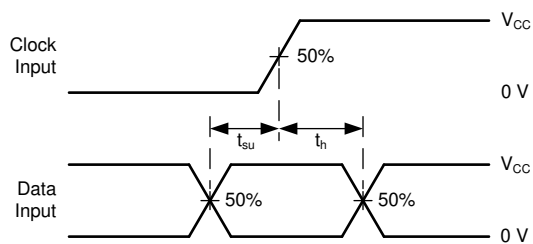

Figure 7-3. Voltage Waveforms, Setup and Hold Times

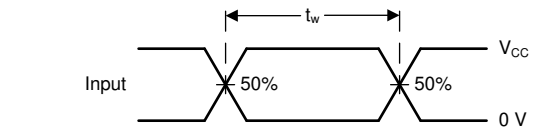
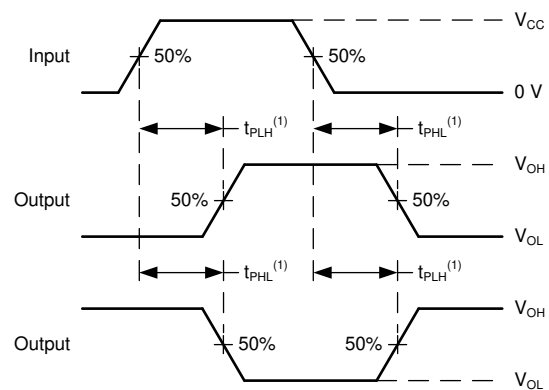
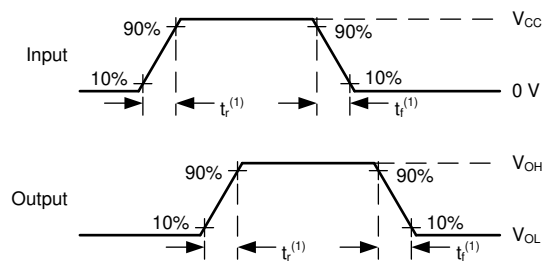

Figure 7-2. Voltage Waveforms, Pulse Duration



(1) The greater between t_{pLH} and t_{pHL} is the same as t_{pd} .

Figure 7-4. Voltage Waveforms Propagation Delays



(1) The greater between t_r and t_f is the same as t_t .

Figure 7-5. Voltage Waveforms, Input and Output Transition Times

8 Detailed Description

8.1 Overview

The SN74HCT165-Q1 is a parallel- or serial-in, serial-out 8-bit shift register.

This device has two modes of operation: load data, and shift data.

When the shift or load (SH/\overline{LD}) input is held in the low state, the internal registers are loaded with data from the eight lettered inputs (A-H). This operation is asynchronous. In this state, the output (Q) will have the same state as the input H, while the inverted output (\overline{Q}) will have the opposite state.

When the shift or load (SH/\overline{LD}) input is held in the high state, the internal registers hold their current state until a clock pulse is received. On the rising edge of the clock (CLK) input, data from the serial input will be loaded into the first register, and the data in the internal registers will be shifted by one place. The last register will lose its value. The output (Q) will always be in the same state as the last register, and the inverted output (\overline{Q}) will have the opposite state. The clock inhibit (CLK INH) input can be held high to prevent clock pulses from being detected. CLK and CLK INH are interchangeable inputs.

8.2 Functional Block Diagram

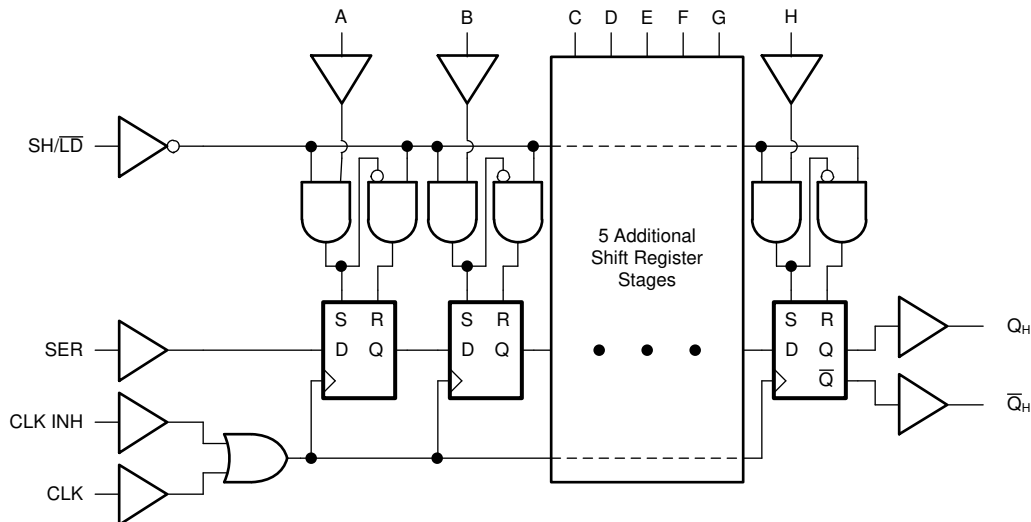

Figure 8-1. Logic Diagram (Positive Logic) for SN74HCT165-Q1

8.3 Feature Description

8.3.1 Balanced CMOS Push-Pull Outputs

This device includes balanced CMOS push-pull outputs. The term *balanced* indicates that the device can sink and source similar currents. The drive capability of this device may create fast edges into light loads so routing and load conditions should be considered to prevent ringing. Additionally, the outputs of this device are capable of driving larger currents than the device can sustain without being damaged. It is important for the output power of the device to be limited to avoid damage due to overcurrent. The electrical and thermal limits defined in the *Absolute Maximum Ratings* must be followed at all times.

Unused push-pull CMOS outputs should be left disconnected.

8.3.2 TTL-Compatible CMOS Inputs

This device includes TTL-compatible CMOS inputs. These inputs are specifically designed to interface with TTL logic devices by having a reduced input voltage threshold.

TTL-compatible CMOS inputs are high impedance and are typically modeled as a resistor in parallel with the input capacitance given in the *Electrical Characteristics*. The worst case resistance is calculated with the maximum input voltage, given in the *Absolute Maximum Ratings*, and the maximum input leakage current, given in the *Electrical Characteristics*, using Ohm's law ($R = V \div I$).

TTL-compatible CMOS inputs require that input signals transition between valid logic states quickly, as defined by the input transition time or rate in the *Recommended Operating Conditions* table. Failing to meet this specification will result in excessive power consumption and could cause oscillations. More details can be found in the [Implications of Slow or Floating CMOS Inputs](#) application report.

Do not leave TTL-compatible CMOS inputs floating at any time during operation. Unused inputs must be terminated at V_{CC} or GND. If a system will not be actively driving an input at all times, a pull-up or pull-down resistor can be added to provide a valid input voltage during these times. The resistor value will depend on multiple factors; however, a 10-k Ω resistor is recommended and will typically meet all requirements.

8.3.3 Latching Logic

This device includes latching logic circuitry. Latching circuits commonly include D-type latches and D-type flip-flops, but include all logic circuits that act as volatile memory.

When the device is powered on, the state of each latch is unknown. There is no default state for each latch at start-up.

The output state of each latching logic circuit only remains stable as long as power is applied to the device within the supply voltage range specified in the *Recommended Operating Conditions* table.

8.3.4 Clamp Diode Structure

The inputs and outputs to this device have both positive and negative clamping diodes as depicted in [Figure 8-2](#).

CAUTION

Voltages beyond the values specified in the *Absolute Maximum Ratings* table can cause damage to the device. The input and output voltage ratings may be exceeded if the input and output clamp-current ratings are observed.

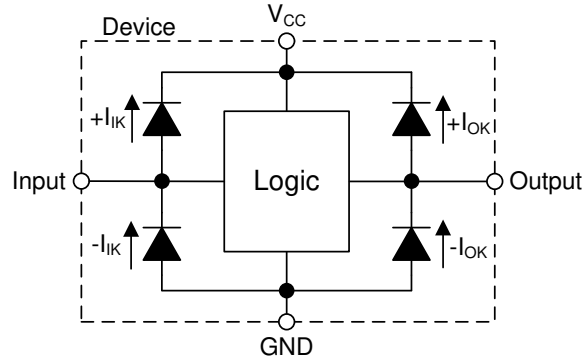

Figure 8-2. Electrical Placement of Clamping Diodes for Each Input and Output

8.4 Device Functional Modes

The [Operating Mode Table](#) and the [Output Function Table](#) list the functional modes of the SN74HCT165-Q1.

Table 8-1. Operating Mode Table

INPUTS ⁽¹⁾			FUNCTION
SH/LD	CLK	CLK INH	
L	X	X	Parallel load
H	H	X	No change
H	X	H	No change
H	L	↑	Shift ⁽²⁾
H	↑	L	Shift ⁽²⁾

- (1) H = High Voltage Level, L = Low Voltage Level, X = Do not care, ↑ = Low to High transition.
 (2) Shift : Content of each internal register shifts towards serial output Q_H. Data at SER is shifted into the first register.

Table 8-2. Output Function Table

INTERNAL REGISTERS ^{(1) (2)}		OUTPUTS ⁽²⁾	
A – G	H	Q	Q̄
X	L	L	H
X	H	H	L

- (1) Internal registers refer to the shift registers inside the device. These values are set by either loading data from the parallel inputs, or by clocking data in from the serial input.
 (2) H = High Voltage Level, L = Low Voltage Level, X = Do not care.

9 Application and Implementation

Note

Information in the following applications sections is not part of the TI component specification, and TI does not warrant its accuracy or completeness. TI's customers are responsible for determining suitability of components for their purposes, as well as validating and testing their design implementation to confirm system functionality.

9.1 Application Information

The SN74HCT165-Q1 is a parallel-input shift register, which can be used to reduce the number of required inputs on a system controller very significantly in some applications. Parallel data is loaded into the shift register, then the stored data can be loaded into a serial input of the system controller by clocking the shift register.

Multiple shift registers can be cascaded to provide more data inputs while still only using a single serial input to the system controller. This process is primarily limited by the required data input rate and timing characteristics of the selected shift register, as defined in the *Timing Characteristics* and *Switching Characteristics* tables.

An example block diagram is shown for using a single shift register in the *Typical Application Block Diagram* below.

9.2 Typical Application

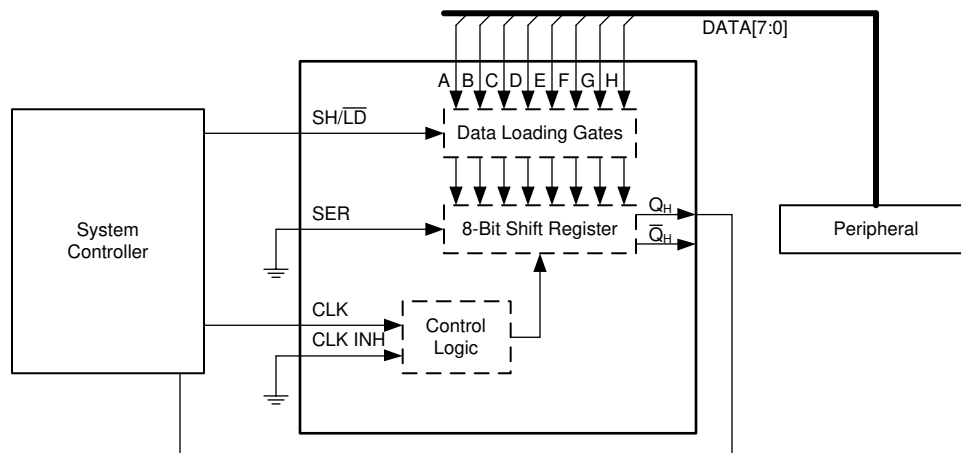

Figure 9-1. Typical Application Block Diagram

9.2.1 Design Requirements

9.2.1.1 Power Considerations

Ensure the desired supply voltage is within the range specified in the *Recommended Operating Conditions*. The supply voltage sets the device's electrical characteristics as described in the *Electrical Characteristics*.

The positive voltage supply must be capable of sourcing current equal to the total current to be sourced by all outputs of the SN74HCT165-Q1 plus the maximum static supply current, I_{CC} , listed in *Electrical Characteristics* and any transient current required for switching. The logic device can only source as much current as is provided by the positive supply source. Be sure not to exceed the maximum total current through V_{CC} listed in the *Absolute Maximum Ratings*.

The ground must be capable of sinking current equal to the total current to be sunk by all outputs of the SN74HCT165-Q1 plus the maximum supply current, I_{CC} , listed in *Electrical Characteristics*, and any transient current required for switching. The logic device can only sink as much current as can be sunk into its ground connection. Be sure not to exceed the maximum total current through GND listed in the *Absolute Maximum Ratings*.

The SN74HCT165-Q1 can drive a load with a total capacitance less than or equal to 50 pF while still meeting all of the datasheet specifications. Larger capacitive loads can be applied, however it is not recommended to exceed 50 pF.

The SN74HCT165-Q1 can drive a load with total resistance described by $R_L \geq V_O / I_O$, with the output voltage and current defined in the *Electrical Characteristics* table with V_{OH} and V_{OL} . When outputting in the high state, the output voltage in the equation is defined as the difference between the measured output voltage and the supply voltage at the V_{CC} pin.

Total power consumption can be calculated using the information provided in the [CMOS Power Consumption and Cpd Calculation](#) application report.

Thermal increase can be calculated using the information provided in the [Thermal Characteristics of Standard Linear and Logic \(SLL\) Packages and Devices](#) application report.

CAUTION

The maximum junction temperature, $T_{J(max)}$ listed in the *Absolute Maximum Ratings*, is an additional limitation to prevent damage to the device. Do not violate any values listed in the *Absolute Maximum Ratings*. These limits are provided to prevent damage to the device.

9.2.1.2 Input Considerations

Input signals must cross $V_{IL(max)}$ to be considered a logic LOW, and $V_{IH(min)}$ to be considered a logic HIGH. Do not exceed the maximum input voltage range found in the *Absolute Maximum Ratings*.

Unused inputs must be terminated to either V_{CC} or ground. These can be directly terminated if the input is completely unused, or they can be connected with a pull-up or pull-down resistor if the input is to be used sometimes, but not always. A pull-up resistor is used for a default state of HIGH, and a pull-down resistor is used for a default state of LOW. The resistor size is limited by drive current of the controller, leakage current into the SN74HCT165-Q1, as specified in the *Electrical Characteristics*, and the desired input transition rate. A 10-k Ω resistor value is often used due to these factors.

The SN74HCT165-Q1 has CMOS inputs and thus requires fast input transitions to operate correctly, as defined in the *Recommended Operating Conditions* table. Slow input transitions can cause oscillations, additional power consumption, and reduction in device reliability.

Refer to the *Feature Description* section for additional information regarding the inputs for this device.

9.2.1.3 Output Considerations

The positive supply voltage is used to produce the output HIGH voltage. Drawing current from the output will decrease the output voltage as specified by the V_{OH} specification in the *Electrical Characteristics*. The ground voltage is used to produce the output LOW voltage. Sinking current into the output will increase the output voltage as specified by the V_{OL} specification in the *Electrical Characteristics*.

Push-pull outputs that could be in opposite states, even for a very short time period, should never be connected directly together. This can cause excessive current and damage to the device.

Two channels within the same device with the same input signals can be connected in parallel for additional output drive strength.

Unused outputs can be left floating. Do not connect outputs directly to V_{CC} or ground.

Refer to *Feature Description* section for additional information regarding the outputs for this device.

9.2.2 Detailed Design Procedure

1. Add a decoupling capacitor from V_{CC} to GND. The capacitor needs to be placed physically close to the device and electrically close to both the V_{CC} and GND pins. An example layout is shown in the *Layout* section.
2. Ensure the capacitive load at the output is ≤ 50 pF. This is not a hard limit, however it will ensure optimal performance. This can be accomplished by providing short, appropriately sized traces from the SN74HCT165-Q1 to the receiving device(s).
3. Ensure the resistive load at the output is larger than $(V_{CC} / I_{O(max)}) \Omega$. This will ensure that the maximum output current from the *Absolute Maximum Ratings* is not violated. Most CMOS inputs have a resistive load measured in megaohms; much larger than the minimum calculated above.
4. Thermal issues are rarely a concern for logic gates, however the power consumption and thermal increase can be calculated using the steps provided in the application report, [CMOS Power Consumption and Cpd Calculation](#).

9.2.3 Application Curve

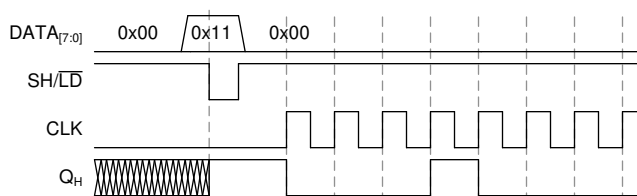

Figure 9-2. Application Timing Diagram

10 Power Supply Recommendations

The power supply can be any voltage between the minimum and maximum supply voltage rating located in the *Recommended Operating Conditions*. Each V_{CC} terminal should have a good bypass capacitor to prevent power disturbance. A 0.1- μF capacitor is recommended for this device. It is acceptable to parallel multiple bypass caps to reject different frequencies of noise. The 0.1- μF and 1- μF capacitors are commonly used in parallel. The bypass capacitor should be installed as close to the power terminal as possible for best results, as shown in given example layout image.

11 Layout

11.1 Layout Guidelines

When using multiple-input and multiple-channel logic devices inputs must not ever be left floating. In many cases, functions or parts of functions of digital logic devices are unused; for example, when only two inputs of a triple-input AND gate are used or only 3 of the 4 buffer gates are used. Such unused input pins must not be left unconnected because the undefined voltages at the outside connections result in undefined operational states. All unused inputs of digital logic devices must be connected to a logic high or logic low voltage, as defined by the input voltage specifications, to prevent them from floating. The logic level that must be applied to any particular unused input depends on the function of the device. Generally, the inputs are tied to GND or V_{CC} , whichever makes more sense for the logic function or is more convenient.

11.2 Layout Example

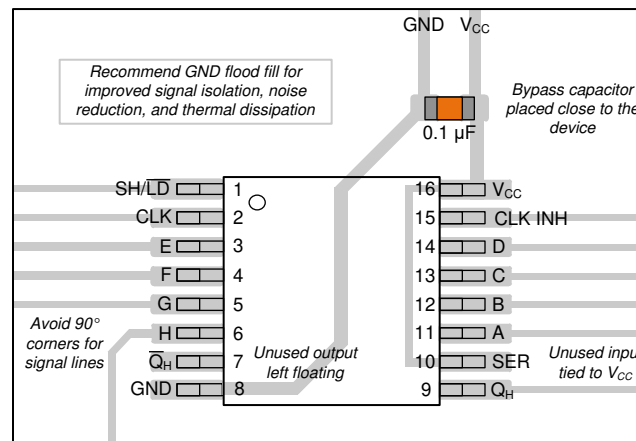

Figure 11-1. Example Layout for the SN74HCT165-Q1 in the PW Package

12 Device and Documentation Support

TI offers an extensive line of development tools. Tools and software to evaluate the performance of the device, generate code, and develop solutions are listed below.

12.1 Documentation Support

12.1.1 Related Documentation

For related documentation, see the following:

- Texas Instruments, [HCMOS Design Considerations application report](#)
- Texas Instruments, [CMOS Power Consumption and \$C_{pd}\$ Calculation application report](#)
- Texas Instruments, [Designing With Logic application report](#)

12.2 Receiving Notification of Documentation Updates

To receive notification of documentation updates, navigate to the device product folder on [ti.com](#). Click on *Subscribe to updates* to register and receive a weekly digest of any product information that has changed. For change details, review the revision history included in any revised document.

12.3 Support Resources

TI E2E™ [support forums](#) are an engineer's go-to source for fast, verified answers and design help — straight from the experts. Search existing answers or ask your own question to get the quick design help you need.

Linked content is provided "AS IS" by the respective contributors. They do not constitute TI specifications and do not necessarily reflect TI's views; see TI's [Terms of Use](#).

12.4 Trademarks

TI E2E™ is a trademark of Texas Instruments.

All trademarks are the property of their respective owners.

12.5 Electrostatic Discharge Caution



This integrated circuit can be damaged by ESD. Texas Instruments recommends that all integrated circuits be handled with appropriate precautions. Failure to observe proper handling and installation procedures can cause damage.

ESD damage can range from subtle performance degradation to complete device failure. Precision integrated circuits may be more susceptible to damage because very small parametric changes could cause the device not to meet its published specifications.

12.6 Glossary

[TI Glossary](#) This glossary lists and explains terms, acronyms, and definitions.

13 Mechanical, Packaging, and Orderable Information

The following pages include mechanical, packaging, and orderable information. This information is the most current data available for the designated devices. This data is subject to change without notice and revision of this document. For browser-based versions of this data sheet, refer to the left-hand navigation.

PACKAGING INFORMATION

Orderable Device	Status (1)	Package Type	Package Drawing	Pins	Package Qty	Eco Plan (2)	Lead finish/ Ball material (6)	MSL Peak Temp (3)	Op Temp (°C)	Device Marking (4/5)	Samples
SN74HCT165QPWRQ1	ACTIVE	TSSOP	PW	16	2000	RoHS & Green	NIPDAU	Level-1-260C-UNLIM	-40 to 125	HT165Q	Samples

(1) The marketing status values are defined as follows:

ACTIVE: Product device recommended for new designs.

LIFEBUY: TI has announced that the device will be discontinued, and a lifetime-buy period is in effect.

NRND: Not recommended for new designs. Device is in production to support existing customers, but TI does not recommend using this part in a new design.

PREVIEW: Device has been announced but is not in production. Samples may or may not be available.

OBSELETE: TI has discontinued the production of the device.

(2) **RoHS:** TI defines "RoHS" to mean semiconductor products that are compliant with the current EU RoHS requirements for all 10 RoHS substances, including the requirement that RoHS substance do not exceed 0.1% by weight in homogeneous materials. Where designed to be soldered at high temperatures, "RoHS" products are suitable for use in specified lead-free processes. TI may reference these types of products as "Pb-Free".

RoHS Exempt: TI defines "RoHS Exempt" to mean products that contain lead but are compliant with EU RoHS pursuant to a specific EU RoHS exemption.

Green: TI defines "Green" to mean the content of Chlorine (Cl) and Bromine (Br) based flame retardants meet JS709B low halogen requirements of <=1000ppm threshold. Antimony trioxide based flame retardants must also meet the <=1000ppm threshold requirement.

(3) MSL, Peak Temp. - The Moisture Sensitivity Level rating according to the JEDEC industry standard classifications, and peak solder temperature.

(4) There may be additional marking, which relates to the logo, the lot trace code information, or the environmental category on the device.

(5) Multiple Device Markings will be inside parentheses. Only one Device Marking contained in parentheses and separated by a "-" will appear on a device. If a line is indented then it is a continuation of the previous line and the two combined represent the entire Device Marking for that device.

(6) Lead finish/Ball material - Orderable Devices may have multiple material finish options. Finish options are separated by a vertical ruled line. Lead finish/Ball material values may wrap to two lines if the finish value exceeds the maximum column width.

Important Information and Disclaimer:The information provided on this page represents TI's knowledge and belief as of the date that it is provided. TI bases its knowledge and belief on information provided by third parties, and makes no representation or warranty as to the accuracy of such information. Efforts are underway to better integrate information from third parties. TI has taken and continues to take reasonable steps to provide representative and accurate information but may not have conducted destructive testing or chemical analysis on incoming materials and chemicals. TI and TI suppliers consider certain information to be proprietary, and thus CAS numbers and other limited information may not be available for release.

In no event shall TI's liability arising out of such information exceed the total purchase price of the TI part(s) at issue in this document sold by TI to Customer on an annual basis.

OTHER QUALIFIED VERSIONS OF SN74HCT165-Q1 :

- Catalog : [SN74HCT165](#)

NOTE: Qualified Version Definitions:

- Catalog - TI's standard catalog product

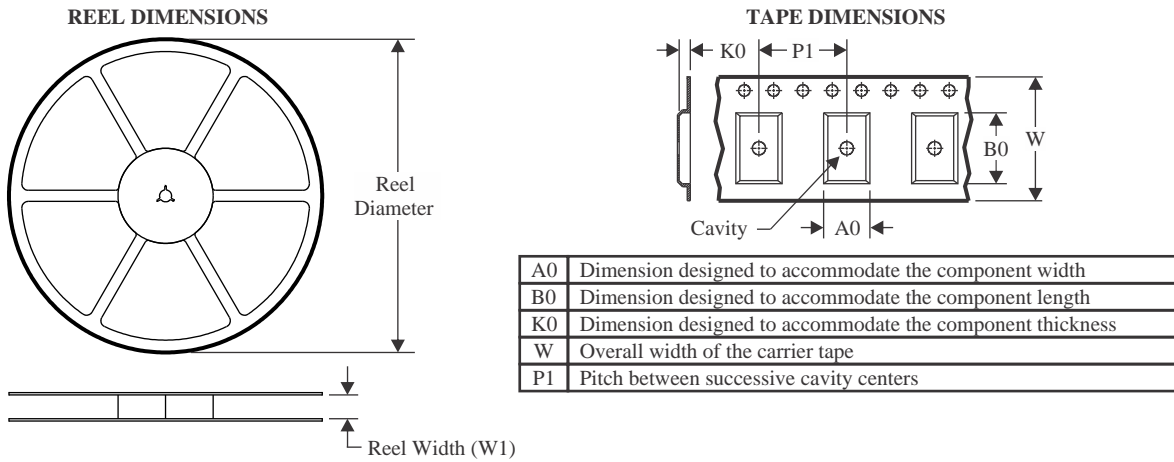
TAPE AND REEL INFORMATION

QUADRANT ASSIGNMENTS FOR PIN 1 ORIENTATION IN TAPE

*All dimensions are nominal

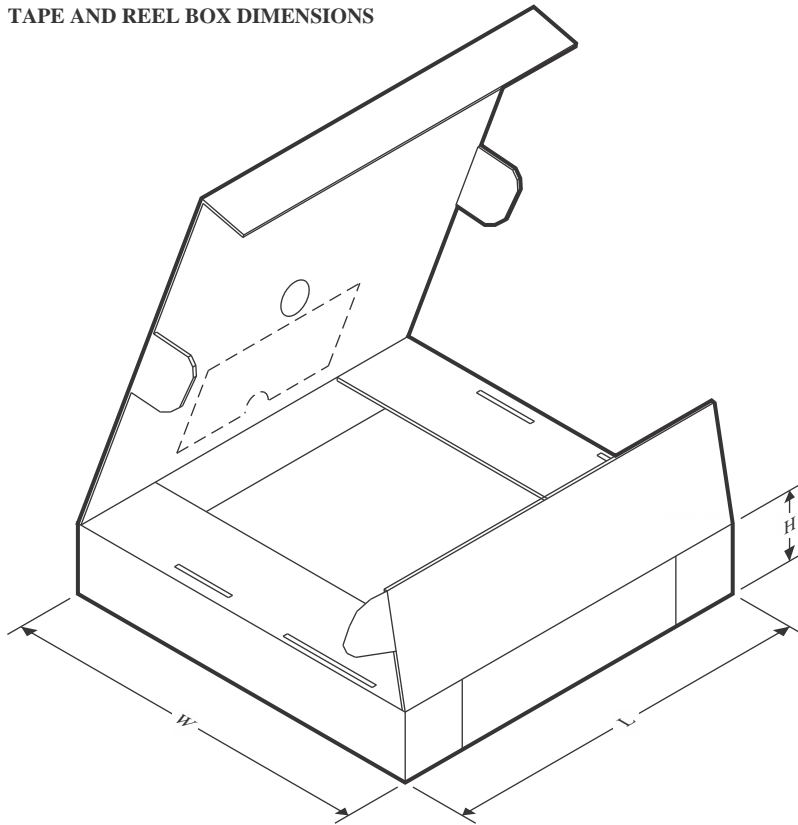
Device	Package Type	Package Drawing	Pins	SPQ	Reel Diameter (mm)	Reel Width W1 (mm)	A0 (mm)	B0 (mm)	K0 (mm)	P1 (mm)	W (mm)	Pin1 Quadrant
SN74HCT165QPWRQ1	TSSOP	PW	16	2000	330.0	12.4	6.9	5.6	1.6	8.0	12.0	Q1

TAPE AND REEL BOX DIMENSIONS

*All dimensions are nominal

Device	Package Type	Package Drawing	Pins	SPQ	Length (mm)	Width (mm)	Height (mm)
SN74HCT165QPWRQ1	TSSOP	PW	16	2000	356.0	356.0	35.0

EXAMPLE BOARD LAYOUT

PW0016A

TSSOP - 1.2 mm max height

SMALL OUTLINE PACKAGE



LAND PATTERN EXAMPLE
EXPOSED METAL SHOWN
SCALE: 10X



4220204/A 02/2017

NOTES: (continued)

- 6. Publication IPC-7351 may have alternate designs.
- 7. Solder mask tolerances between and around signal pads can vary based on board fabrication site.

EXAMPLE STENCIL DESIGN

PW0016A

TSSOP - 1.2 mm max height

SMALL OUTLINE PACKAGE



SOLDER PASTE EXAMPLE
BASED ON 0.125 mm THICK STENCIL
SCALE: 10X

4220204/A 02/2017

NOTES: (continued)

8. Laser cutting apertures with trapezoidal walls and rounded corners may offer better paste release. IPC-7525 may have alternate design recommendations.
9. Board assembly site may have different recommendations for stencil design.

IMPORTANT NOTICE AND DISCLAIMER

TI PROVIDES TECHNICAL AND RELIABILITY DATA (INCLUDING DATA SHEETS), DESIGN RESOURCES (INCLUDING REFERENCE DESIGNS), APPLICATION OR OTHER DESIGN ADVICE, WEB TOOLS, SAFETY INFORMATION, AND OTHER RESOURCES "AS IS" AND WITH ALL FAULTS, AND DISCLAIMS ALL WARRANTIES, EXPRESS AND IMPLIED, INCLUDING WITHOUT LIMITATION ANY IMPLIED WARRANTIES OF MERCHANTABILITY, FITNESS FOR A PARTICULAR PURPOSE OR NON-INFRINGEMENT OF THIRD PARTY INTELLECTUAL PROPERTY RIGHTS.

These resources are intended for skilled developers designing with TI products. You are solely responsible for (1) selecting the appropriate TI products for your application, (2) designing, validating and testing your application, and (3) ensuring your application meets applicable standards, and any other safety, security, regulatory or other requirements.

These resources are subject to change without notice. TI grants you permission to use these resources only for development of an application that uses the TI products described in the resource. Other reproduction and display of these resources is prohibited. No license is granted to any other TI intellectual property right or to any third party intellectual property right. TI disclaims responsibility for, and you will fully indemnify TI and its representatives against, any claims, damages, costs, losses, and liabilities arising out of your use of these resources.

TI's products are provided subject to [TI's Terms of Sale](#) or other applicable terms available either on ti.com or provided in conjunction with such TI products. TI's provision of these resources does not expand or otherwise alter TI's applicable warranties or warranty disclaimers for TI products.

TI objects to and rejects any additional or different terms you may have proposed.

Mailing Address: Texas Instruments, Post Office Box 655303, Dallas, Texas 75265
Copyright © 2022, Texas Instruments Incorporated

Looking for pricing, stock, or lifecycle information?

Click below to explore more details on WIN SOURCE:

 [View SN74HCT165QPWRQ1 on WIN SOURCE](#)

 [Texas Instruments](#) Information

Optimize Your Supply Chain with WIN SOURCE Solutions

-  Global Sourcing Solution
-  Obsolete Management
-  Cost Control Management
-  Shortage Management
-  Alternative Solution
-  Excess Inventory Management