



**THE DATASHEET OF
DS36C200MX/NOPB**



DS36C200 Dual High Speed Bi-Directional Differential Transceiver

 Check for Samples: [DS36C200](#)

FEATURES

- Optimized for DSS to DVHS Interface Link
- Compatible IEEE 1394 Signaling Voltage Levels
- Operates Above 100 Mbps
- Bi-directional Transceivers
- 14-lead SOIC Package
- Ultra Low Power Dissipation
- ± 100 mV Receiver Sensitivity
- Low Differential Output Swing Typical 210 mV
- High Impedance During Power Off

DESCRIPTION

The DS36C200 is a dual transceiver device optimized for high data rate and low power applications. This device provides a single chip solution for a dual high speed bi-directional interface. Also, both control pins may be routed together for single bit control of datastreams. Both control pins are adjacent to each other for ease of routing them together. The DS36C200 is compatible with IEEE 1394 physical layer and may be used as an economical solution with some considerations. Please reference the application information on 1394 for more information. The device is in a 14-lead small outline package. The differential driver outputs provides low EMI with its low output swings typically 210 mV. The receiver offers ± 100 mV threshold sensitivity, in addition to common-mode noise protection.

Connection Diagram

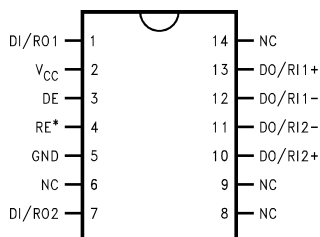

Note: * denotes active LOW pin

Figure 1. SOIC Package
See Package Number D (R-PDSO-G14)

Functional Diagram

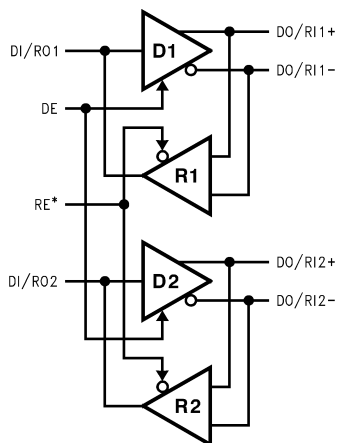

Please be aware that an important notice concerning availability, standard warranty, and use in critical applications of Texas Instruments semiconductor products and disclaimers thereto appears at the end of this data sheet.

All trademarks are the property of their respective owners.



These devices have limited built-in ESD protection. The leads should be shorted together or the device placed in conductive foam during storage or handling to prevent electrostatic damage to the MOS gates.

Absolute Maximum Ratings⁽¹⁾⁽²⁾

Supply Voltage (V_{CC})	-0.3V to +6V
Enable Input Voltage (DE, RE*)	-0.3V to ($V_{CC} + 0.3V$)
Voltage (DI/RO)	-0.3V to +5.9V
Voltage (DO/RI±)	-0.3V to +5.9V
Maximum Package Power Dissipation @+25°C	
M Package	1255 mW
Derate M Package	10.04 mW/°C above +25°C
Storage Temperature Range	-65°C to +150°C
Lead Temperature Range (Soldering, 4 sec.)	+260°C
ESD Rating ⁽³⁾	
(HBM, 1.5 kΩ, 100 pF)	≥ 3.5 kV
(EIAJ, 0 Ω, 200 pF)	≥ 300V

- (1) "Absolute Maximum Ratings" are those values beyond which the safety of the device cannot be ensured. They are not meant to imply that the devices should be operated at these limits. The table of "Electrical Characteristics" specifies conditions of device operation.
 (2) If Military/Aerospace specified devices are required, please contact the TI Sales Office/Distributors for availability and specifications.
 (3) ESD Rating: HBM (1.5 kΩ, 100 pF) ≥ 3.5 kV EIAJ (0Ω, 200 pF) ≥ 300V

Recommended Operating Conditions

	Min	Typ	Max	Units
Supply Voltage (V_{CC})	+4.5	+5.0	+5.5	V
Receiver Input Voltage	0		2.4	V
Operating Free Air Temperature (T_A)	0	25	70	°C

Electrical Characteristics⁽¹⁾⁽²⁾⁽³⁾

Over supply voltage and operating temperature ranges, unless otherwise specified

Symbol	Parameter	Conditions	Pin	Min	Typ	Max	Units	
DIFFERENTIAL DRIVER CHARACTERISTICS (RE* = V_{CC})								
V _{OD}	Output Differential Voltage	R _L = 55Ω, (Figure 2)	DO+, DO-	172	210	285	mV	
ΔV _{OD}	V _{OD} Magnitude Change			0	4	35	mV	
V _{OH}	Output High Voltage				1.36		V	
V _{OL}	Output Low Voltage				1.15		V	
V _{OS}	Offset Voltage			1.0	1.25	1.6	V	
ΔV _{OS}	Offset Magnitude Change			0	5	25	mV	
I _{OZD}	TRI-STATE Leakage	V _{OUT} = V _{CC} or GND			-10	±1	+10	μA
I _{OXD}	Power-Off Leakage	V _{OUT} = 5.5V or GND, V _{CC} = 0V			-10	±1	+10	μA
I _{OSD}	Output Short Circuit Current	V _{OUT} = 0V				-4	-9	mA
DIFFERENTIAL RECEIVER CHARACTERISTICS (DE = GND)								
V _{TH}	Input Threshold High	V _{CM} = 0V to 2.3V	RI+, RI-			+100	mV	
V _{TL}	Input Threshold Low			-100			mV	
I _{IN}	Input Current	V _{IN} = +2.4V or 0V		-10	±1	+10	μA	
V _{OH}	Output High Voltage	I _{OH} = -400 μA	RO	3.8	4.9		V	
		Inputs Open		3.8	4.9		V	
		Inputs Terminated, R _t = 55Ω		3.8	4.9		V	
		Inputs Shorted, V _{ID} = 0V			4.9		V	
V _{OL}	Output Low Voltage	I _{OL} = 2.0 mA, V _{ID} = -200 mV			0.1	0.4	V	
I _{OSR}	Output Short Circuit Current	V _{OUT} = 0V		-15	-60	-100	mA	
DEVICE CHARACTERISTICS								
V _{IH}	Input High Voltage		DI, DE RE*	2.0		V _{CC}	V	
V _{IL}	Input Low Voltage			GND		0.8	V	
I _{IH}	Input High Current	V _{IN} = V _{CC} or 2.4V				±1	±10	μA
I _{IL}	Input Low Current	V _{IN} = GND or 0.4V				±1	±10	μA
V _{CL}	Input Clamp Voltage	I _{CL} = -18 mA			-1.5	-0.8		V
I _{CCD}	Power Supply Current	No Load, DE = RE* = V _{CC}	V _{CC}		3	7	mA	
		R _L = 55Ω, DE = RE* = V _{CC}			11	17	mA	
		DE = RE* = 0V			6	10	mA	
I _{CCR}								

- (1) Current into device pins is defined as positive. Current out of device pins is defined as negative. All voltages are referenced to ground except V_{OD} and V_{ID}.
- (2) All typicals are given for V_{CC} = +5.0V and T_A = +25°C.
- (3) The DS36C200 is a current mode device and only function with datasheet specification when a resistive load is applied to the drivers outputs.

Switching Characteristics

Over supply voltage and operating temperature ranges, unless otherwise specified. ⁽¹⁾ ⁽²⁾

Symbol	Parameter	Conditions	Min	Typ	Max	Units
DIFFERENTIAL DRIVER CHARACTERISTICS						
t_{PHLD}	Differential Propagation Delay High to Low	$R_L = 55\Omega$, $C_L = 10$ pF (Figure 3 and Figure 4)	1.0	2.5	5.5	ns
t_{PLHD}	Differential Propagation Delay Low to High		1.0	2.6	5.5	ns
t_{SKD}	Differential Skew $ t_{PHLD} - t_{PLHD} $		0	0.1	2	ns
t_{TLH}	Transition Time Low to High		0	0.5	2	ns
t_{THL}	Transition Time High to Low		0	0.5	2	ns
t_{PHZ}	Disable Time High to Z	$R_L = 55\Omega$ (Figure 5 and Figure 6)	0.3	5	20	ns
t_{PLZ}	Disable Time Low to Z		0.3	5	20	ns
t_{PZH}	Enable Time Z to High		0.3	10	30	ns
t_{PZL}	Enable Time Z to Low		0.3	10	30	ns
DIFFERENTIAL RECEIVER CHARACTERISTICS						
t_{PHLD}	Differential Propagation Delay High to Low	$C_L = 10$ pF, $V_{ID} = 200$ mV (Figure 7 and Figure 8)	1.5	5	9	ns
t_{PLHD}	Differential Propagation Delay Low to High		1.5	4.6	9	ns
t_{SKD}	Differential Skew $ t_{PHLD} - t_{PLHD} $		0	0.4	3	ns
t_r	Rise Time		0	1.5	5	ns
t_f	Fall Time		0	1.5	5	ns
t_{PHZ}	Disable Time High to Z	$C_L = 10$ pF (Figure 9 and Figure 10)	1	5	20	ns
t_{PLZ}	Disable Time Low to Z		1	5	20	ns
t_{PZH}	Enable Time Z to High		0.3	10	30	ns
t_{PZL}	Enable Time Z to Low		0.3	10	30	ns

(1) C_L includes probe and fixture capacitance.

(2) Generator waveform for all tests unless otherwise specified: $f = 1$ MHz, $Z_O = 50\Omega$, $t_r \leq 1$ ns, $t_f \leq 1$ ns (0%–100%).

PARAMETER MEASUREMENT INFORMATION

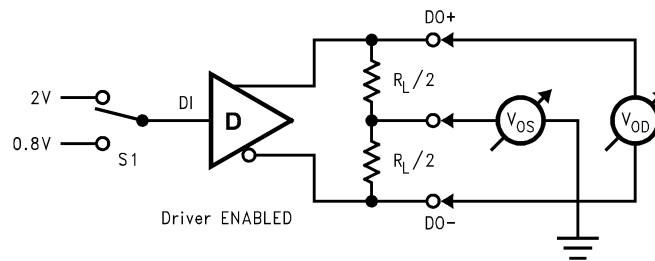

Figure 2. Differential Driver DC Test Circuit

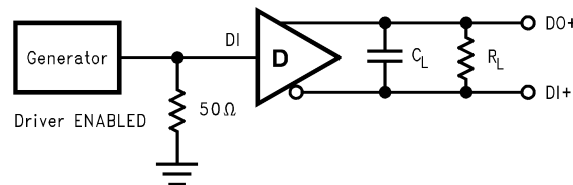

Figure 3. Differential Driver Propagation Delay and Transition Time Test Circuit

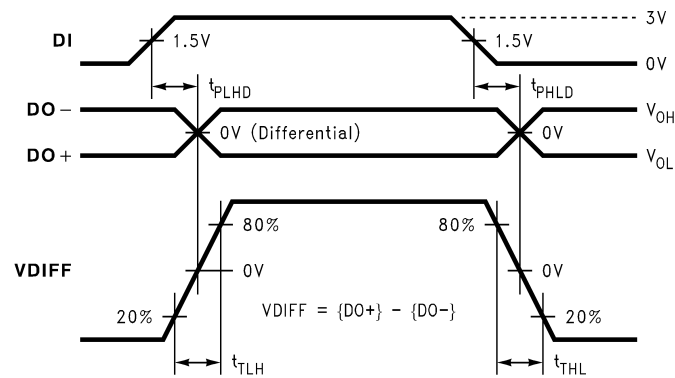

Figure 4. Differential Driver Propagation Delay and Transition Time Waveforms

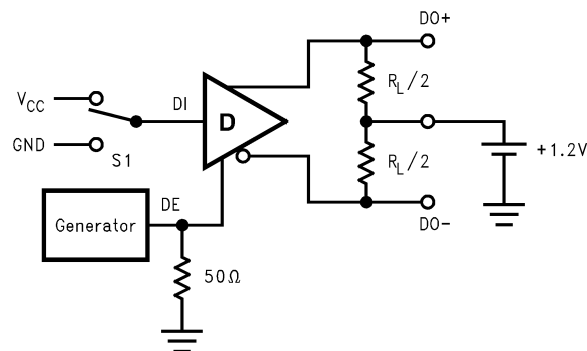

Figure 5. Driver TRI-STATE Delay Test Circuit

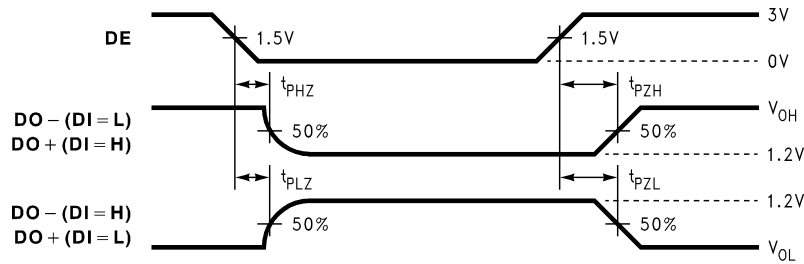

Figure 6. Driver TRI-STATE Delay Waveforms

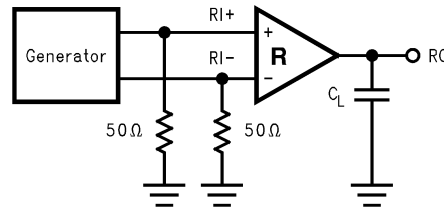

Figure 7. Receiver Propagation Delay and Transition Time Test Circuit

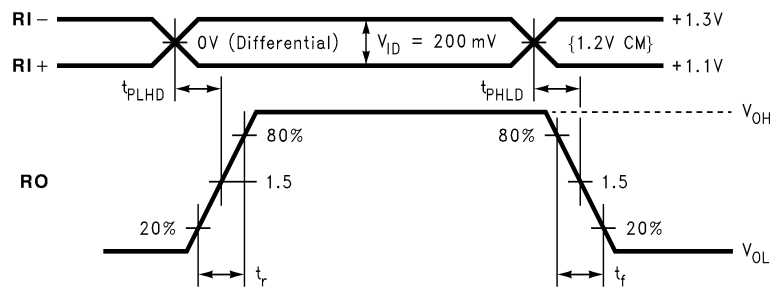

Figure 8. Receiver Propagation Delay and Transition Time Waveforms

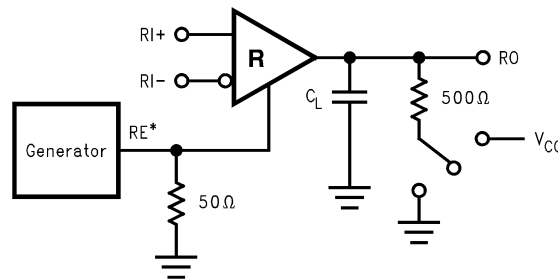

Figure 9. Receiver TRI-STATE Delay Test Circuit

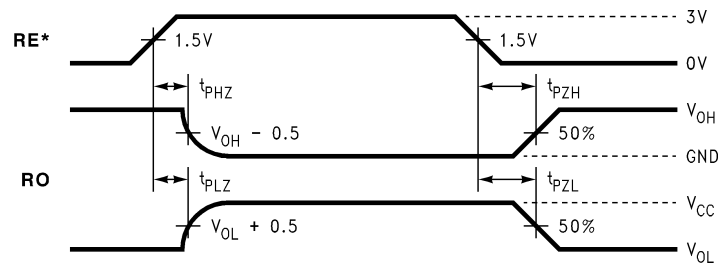

Figure 10. Receiver TRI-STATE Delay Waveforms

APPLICATION INFORMATION

TRUTH TABLES

The DS36C200 has two enable pins DE and RE*, however, the driver and receiver should never be enabled simultaneously. Enabling both could cause multiple channel contention between the receiver output and the driving logic. It is recommended to route the enables together on the PC board. This will allow a single bit [DE/RE*] to control the chip. This DE/RE* bit toggles the DS36C200 between Receive mode and Transmit mode. When the bit is asserted HIGH the device is in Transmit mode. When the bit is asserted LOW the device is in Receive mode. The mode determines the function of the I/O pins: DI/RO, DO/RI+, and DO/RI-. Please note that some of the pins have been identified by its function in the corresponding mode in the three tables below. For example, in Transmit mode the DO/RI+ pin is identified as DO+. This was done for clarity in the tables only and should not be confused with the pin identification throughout the rest of this document. Also note that a logic low on the DE/RE* bit corresponds to a logic low on both the DE pin and the RE* pin. Similarly, a logic high on the DE/RE* bit corresponds to a logic high on both the DE pin and the RE* pin.

Table 1. Receive Mode⁽¹⁾

Input(s)		Input/Output	
DE	RE*	[RI+] - [RI-]	RO
L	L	> +100 mV	H
L	L	< -100 mV	L
L	L	100 mV > & > -100 mV	X
L	H	X	Z

- (1) H = Logic high level
 L = Logic low level
 X = Indeterminate state
 Z = High impedance state

Table 2. Transmit Mode⁽¹⁾

Input(s)		Input/Output		
DE	RE*	DI	DO+	DO-
H	H	L	L	H
H	H	H	H	L
H	H	2 > & > 0.8	X	X
L	H	X	Z	Z

- (1) H = Logic high level
 L = Logic low level
 X = Indeterminate state
 Z = High impedance state

DEVICE PIN DESCRIPTIONS

Pin#	Name (In mode only)	Mode	Description
3	DE	Transmit	Driver Enable: When asserted low driver is disabled. And when asserted high driver is enabled.
1, 7	DI		TTL/CMOS driver input pins
10, 13	DO+		Non-inverting driver output pin
11, 12	DO-		Inverting driver output pin
4	RE*	Receive	Receiver Enable: When asserted low receiver is enabled. And when asserted high receiver is disabled.
1, 7	RO		Receiver output pin
10, 13	RI+		Positive receiver input pin
11, 12	RI-		Negative receiver input pin
5	GND	Transmit and	Ground pin
2	V _{CC}	Receive	Positive power supply pin, +5V ± 10%
6, 8, 9, 14	NC		No Connect

IEEE 1394

The DS36C200 drives and receives IEEE 1394 physical layer signal levels. The current mode driver is capable of driving a 55Ω load with V_{OD} between 172 mV and 285 mV. The DS36C200 is not designed to work with a link layer controller IC requiring full 1394 physical layer compliance to the standard. No clock generator, no arbitration, and no encode/decode logic is provided with this device. For a 1394 link where speed sensing, bus arbitration, and other functions are not required, a controller and the DS36C200 will provide a cost effective, high speed dedicated link. This is shown in [Figure 11](#). In applications that require fully compliant 1394 protocol, a link layer controller and physical layer controller will be required as shown in [Figure 11](#). The physical layer controller supports up to three DS36C200 devices (not shown).

The DS36C200 drivers are current mode drivers and intended to work with a two 110Ω termination resistors in parallel with each other. The termination resistors should match the characteristic impedance of the transmission media. The drivers are current mode devices therefore the resistors are required. Both resistors are required for half duplex operation and should be placed as close to the DO/RI+ and DO/RI- pins as possible at opposite ends of the bus. However, if your application only requires simplex operation, only one termination resistor is required. In addition, note the voltage levels will vary from those in the datasheet due to different loading. Also, AC or unterminated configurations are not used with this device. Multiple node configurations are possible as long as transmission line effects are taken into account. Discontinuities are caused by mid-bus stubs, connectors, and devices that affect signal integrity.

The differential line driver is a balanced current source design. A current mode driver, generally speaking has a high output impedance and supplies a constant current for a range of loads (a voltage mode driver on the other hand supplies a constant voltage for a range of loads). Current is switched through the load in one direction to produce a logic state and in the other direction to produce the other logic state. The typical output current is mere 3.8 mA, a minimum of 3.1 mA, and a maximum of 5.2 mA. The current mode **requires** that a resistive termination be employed to terminate the signal and to complete the loop as shown in [Figure 12](#). The 3.8 mA loop current will develop a differential voltage of 210 mV across the 55Ω termination resistor which the receiver detects with a 110 mV minimum differential noise margin neglecting resistive line losses (driven signal minus receiver threshold (210 mV – 100 mV = 110 mV)). The signal is centered around +1.2V (Driver Offset, V_{OS}) with respect to ground as shown in [Figure 8](#).

The current mode driver provides substantial benefits over voltage mode drivers, such as an RS-422 driver. Its quiescent current remains relatively flat versus switching frequency. Whereas the RS-422 voltage mode driver increases exponentially in most case between 20 MHz–50 MHz. This is due to the overlap current that flows between the rails of the device when the internal gates switch. Whereas the current mode driver switches a fixed current between its output without any substantial overlap current. This is similar to some ECL and PECL devices, but without the heavy static I_{CC} requirements of the ECL/PECL designs. LVDS requires > 80% less current than similar PECL devices. AC specifications for the driver are a tenfold improvement over other existing RS-422 drivers.

Fail-safe Feature:

The LVDS receiver is a high gain, high speed device that amplifies a small differential signal (20mV) to CMOS logic levels. Due to the high gain and tight threshold of the receiver, care should be taken to prevent noise from appearing as a valid signal.

The receiver's internal fail-safe circuitry is designed to source/sink a small amount of current, providing fail-safe protection (a stable known state of HIGH output voltage) for floating, terminated or shorted receiver inputs.

1. **Open Input Pins.** The DS36C200 is a dual transceiver device, and if an application requires only one receiver, the unused channel inputs should be left OPEN. Do not tie the receiver inputs to ground or any other voltages. The input is biased by internal high value pull up or pull down resistors to set the output to a HIGH state. This internal circuitry will ensure a HIGH, stable output state for open inputs.
2. **Terminated Input.** If the driver is disconnected (cable unplugged), or if the driver is in a TRI-STATE or power-off condition, the receiver output will again be in a HIGH state, even with the end of the cable 100Ω termination resistor across the input pins. The unplugged cable can become a floating antenna which can pick up noise. If the cable picks up more than 10mV of differential noise, the receiver may see the noise as a valid signal and switch. To insure that any noise is seen as common-mode and not differential, a balanced interconnect should be used. Twisted pair cable will offer better balance than flat ribbon cable.
3. **Shorted Inputs.** If a fault condition occurs that shorts the receiver inputs together, thus resulting in a 0V differential input voltage, the receiver output will remain in a HIGH state. Shorted input fail-safe is not supported across the common-mode range of the device (GND to 2.4V). It is only supported with inputs shorted and no external common-mode voltage applied.

If there is more than 10mV of differential noise, the receiver may switch or oscillate. If this condition can happen in your application, you may wish to add external fail-safe resistors to create a larger noise margin. External lower value pull up and pull down resistors (for a stronger bias) may be used to boost fail-safe in the presence of higher noise levels. The pull up and pull down resistors should be in the 5kΩ to 15kΩ range to minimize loading and waveform distortion to the driver. The common-mode bias point should be set to approximately 1.2V (less than 1.75V) to be compatible with the internal circuitry.

Additional information on fail-safe biasing of LVDS devices may be found in AN-1194 ([SNLA051](#)).

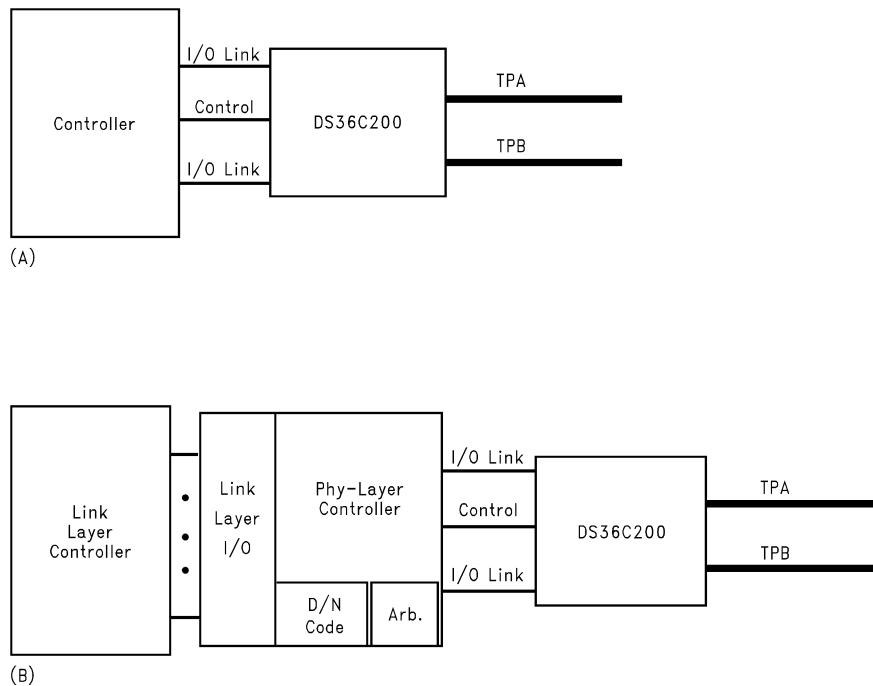

**Figure 11. (A) Dedicated IEEE 1394 Link
(B) Full IEEE 1394 Compliant Link**

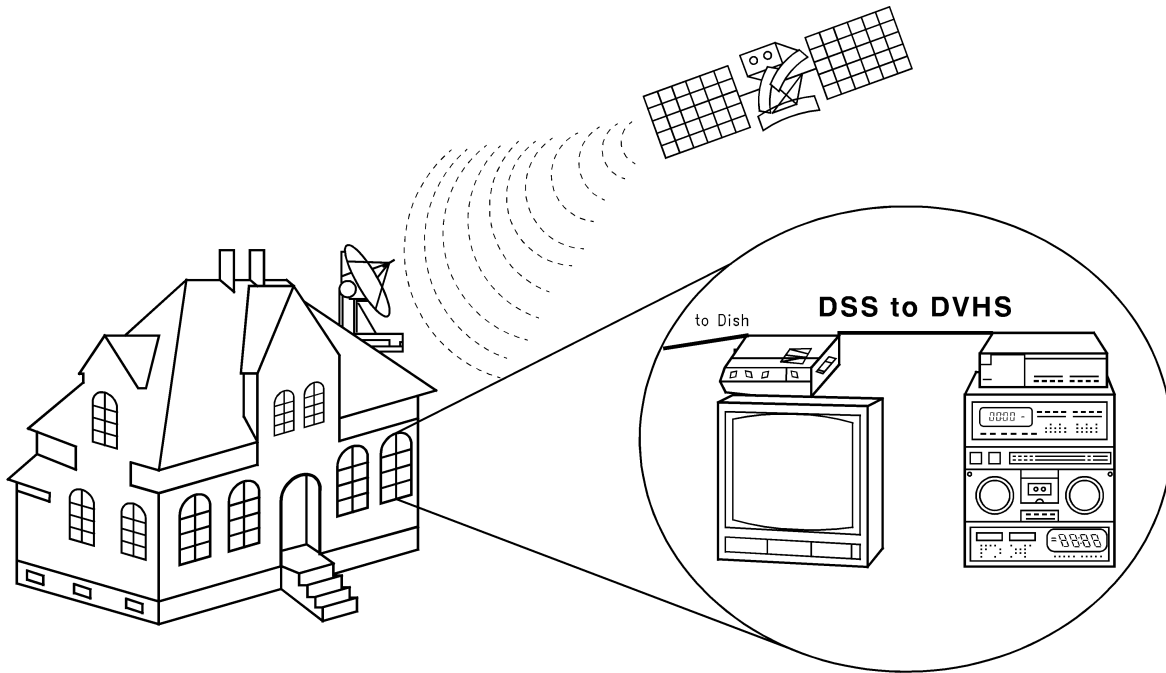

Figure 12. Typical in Home Application

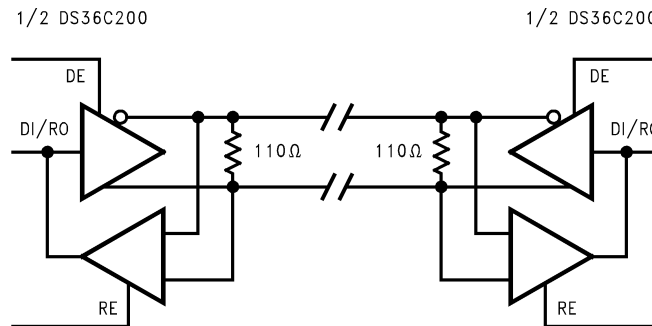

Figure 13. Typical Interface Connection (1)

(1) The DS36C200 is a current mode device and only function with datasheet specification when a resistive load is applied to the drivers outputs.

REVISION HISTORY

Changes from Revision C (April 2013) to Revision D	Page
• Changed layout of National Data Sheet to TI format	10

PACKAGING INFORMATION

Orderable Device	Status (1)	Package Type	Package Drawing	Pins	Package Qty	Eco Plan (2)	Lead/Ball Finish	MSL Peak Temp (3)	Op Temp (°C)	Device Marking (4/5)	Samples
DS36C200M/NOPB	ACTIVE	SOIC	D	14	55	Green (RoHS & no Sb/Br)	CU SN	Level-1-260C-UNLIM	0 to 70	DS36C200M	Samples
DS36C200MX/NOPB	ACTIVE	SOIC	D	14	2500	Green (RoHS & no Sb/Br)	CU SN	Level-1-260C-UNLIM	0 to 70	DS36C200M	Samples

(1) The marketing status values are defined as follows:

ACTIVE: Product device recommended for new designs.

LIFEBUY: TI has announced that the device will be discontinued, and a lifetime-buy period is in effect.

NRND: Not recommended for new designs. Device is in production to support existing customers, but TI does not recommend using this part in a new design.

PREVIEW: Device has been announced but is not in production. Samples may or may not be available.

OBSOLETE: TI has discontinued the production of the device.

(2) Eco Plan - The planned eco-friendly classification: Pb-Free (RoHS), Pb-Free (RoHS Exempt), or Green (RoHS & no Sb/Br) - please check <http://www.ti.com/productcontent> for the latest availability information and additional product content details.

TBD: The Pb-Free/Green conversion plan has not been defined.

Pb-Free (RoHS): TI's terms "Lead-Free" or "Pb-Free" mean semiconductor products that are compatible with the current RoHS requirements for all 6 substances, including the requirement that lead not exceed 0.1% by weight in homogeneous materials. Where designed to be soldered at high temperatures, TI Pb-Free products are suitable for use in specified lead-free processes.

Pb-Free (RoHS Exempt): This component has a RoHS exemption for either 1) lead-based flip-chip solder bumps used between the die and package, or 2) lead-based die adhesive used between the die and leadframe. The component is otherwise considered Pb-Free (RoHS compatible) as defined above.

Green (RoHS & no Sb/Br): TI defines "Green" to mean Pb-Free (RoHS compatible), and free of Bromine (Br) and Antimony (Sb) based flame retardants (Br or Sb do not exceed 0.1% by weight in homogeneous material)

(3) MSL, Peak Temp. -- The Moisture Sensitivity Level rating according to the JEDEC industry standard classifications, and peak solder temperature.

(4) There may be additional marking, which relates to the logo, the lot trace code information, or the environmental category on the device.

(5) Multiple Device Markings will be inside parentheses. Only one Device Marking contained in parentheses and separated by a "~" will appear on a device. If a line is indented then it is a continuation of the previous line and the two combined represent the entire Device Marking for that device.

Important Information and Disclaimer: The information provided on this page represents TI's knowledge and belief as of the date that it is provided. TI bases its knowledge and belief on information provided by third parties, and makes no representation or warranty as to the accuracy of such information. Efforts are underway to better integrate information from third parties. TI has taken and continues to take reasonable steps to provide representative and accurate information but may not have conducted destructive testing or chemical analysis on incoming materials and chemicals. TI and TI suppliers consider certain information to be proprietary, and thus CAS numbers and other limited information may not be available for release.

In no event shall TI's liability arising out of such information exceed the total purchase price of the TI part(s) at issue in this document sold by TI to Customer on an annual basis.

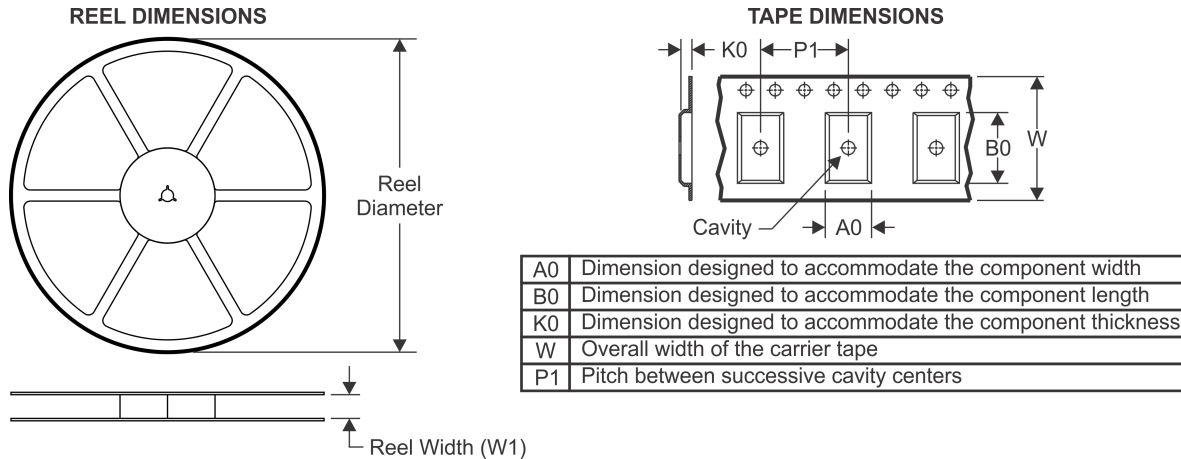
TAPE AND REEL INFORMATION

QUADRANT ASSIGNMENTS FOR PIN 1 ORIENTATION IN TAPE

*All dimensions are nominal

Device	Package Type	Package Drawing	Pins	SPQ	Reel Diameter (mm)	Reel Width W1 (mm)	A0 (mm)	B0 (mm)	K0 (mm)	P1 (mm)	W (mm)	Pin1 Quadrant
DS36C200MX/NOPB	SOIC	D	14	2500	330.0	16.4	6.5	9.35	2.3	8.0	16.0	Q1

TAPE AND REEL BOX DIMENSIONS



*All dimensions are nominal

Device	Package Type	Package Drawing	Pins	SPQ	Length (mm)	Width (mm)	Height (mm)
DS36C200MX/NOPB	SOIC	D	14	2500	367.0	367.0	35.0

D (R-PDSO-G14)

PLASTIC SMALL OUTLINE



- NOTES:
- All linear dimensions are in millimeters.
 - This drawing is subject to change without notice.
 - Publication IPC-7351 is recommended for alternate designs.
 - Laser cutting apertures with trapezoidal walls and also rounding corners will offer better paste release. Customers should contact their board assembly site for stencil design recommendations. Refer to IPC-7525 for other stencil recommendations.
 - Customers should contact their board fabrication site for solder mask tolerances between and around signal pads.

IMPORTANT NOTICE AND DISCLAIMER

TI PROVIDES TECHNICAL AND RELIABILITY DATA (INCLUDING DATASHEETS), DESIGN RESOURCES (INCLUDING REFERENCE DESIGNS), APPLICATION OR OTHER DESIGN ADVICE, WEB TOOLS, SAFETY INFORMATION, AND OTHER RESOURCES "AS IS" AND WITH ALL FAULTS, AND DISCLAIMS ALL WARRANTIES, EXPRESS AND IMPLIED, INCLUDING WITHOUT LIMITATION ANY IMPLIED WARRANTIES OF MERCHANTABILITY, FITNESS FOR A PARTICULAR PURPOSE OR NON-INFRINGEMENT OF THIRD PARTY INTELLECTUAL PROPERTY RIGHTS.

These resources are intended for skilled developers designing with TI products. You are solely responsible for (1) selecting the appropriate TI products for your application, (2) designing, validating and testing your application, and (3) ensuring your application meets applicable standards, and any other safety, security, or other requirements. These resources are subject to change without notice. TI grants you permission to use these resources only for development of an application that uses the TI products described in the resource. Other reproduction and display of these resources is prohibited. No license is granted to any other TI intellectual property right or to any third party intellectual property right. TI disclaims responsibility for, and you will fully indemnify TI and its representatives against, any claims, damages, costs, losses, and liabilities arising out of your use of these resources.

TI's products are provided subject to TI's Terms of Sale (www.ti.com/legal/termsofsale.html) or other applicable terms available either on ti.com or provided in conjunction with such TI products. TI's provision of these resources does not expand or otherwise alter TI's applicable warranties or warranty disclaimers for TI products.

Mailing Address: Texas Instruments, Post Office Box 655303, Dallas, Texas 75265
Copyright © 2019, Texas Instruments Incorporated

Looking for pricing, stock, or lifecycle information?

Click below to explore more details on WIN SOURCE:

 [View DS36C200MX/NOPB on WIN SOURCE](#)

 [Texas Instruments](#) Information

Optimize Your Supply Chain with WIN SOURCE Solutions

-  Global Sourcing Solution
-  Obsolete Management
-  Cost Control Management
-  Shortage Management
-  Alternative Solution
-  Excess Inventory Management