

DS3896/DS3897 BTL Trapezoidal™ Transceivers

Check for Samples: [DS3896](#), [DS3897](#)

FEATURES

- **8 bit DS3896 Transceiver Provides High Package Density**
- **4 bit DS3897 Transceiver Provides Separate Driver Input and Receiver Output Pins**
- **BTL Compatible**
- **Less than 5 pF Output Capacitance for Minimal Bus Loading**
- **1 Volt Bus Signal Swing Reduces Power Consumption**
- **Trapezoidal Driver Waveforms (t_r , $t_f \approx 6$ ns typical) Reduce Noise Coupling to Adjacent Lines**
- **Temperature Insensitive Receiver Thresholds Track the Bus Logic High Level to Maximize Noise Immunity in both High and Low States**
- **Guaranteed A.C. Specifications on Noise Immunity and Propagation Delay Over the Specified Temperature and Supply Voltage Range**
- **Open Collector Driver Output Allows Wire-or Connection**
- **Advanced Low Power Schottky Technology**
- **Glitch Free power Up/Down Protection on Driver and Receiver Outputs**
- **TTL Compatible Driver and Control Inputs and Receiver Outputs**

DESCRIPTION

These advanced transceivers are specifically designed to overcome problems associated with driving a densely populated backplane, and thus provide significant improvement in both speed and data integrity. Their low output capacitance, low output signal swing and noise immunity features make them ideal for driving low impedance buses with minimum power consumption.

The DS3896 is an octal high speed schottky bus transceiver with common control signals, whereas the DS3897 is a quad device with independent driver input and receiver output pins. The DS3897 has a separate driver disable for each driver and is, therefore, suitable for arbitration lines. The separate driver disable pins (E_n) feature internal pull ups and may be left open if not required. On the other hand, the DS3896 provides high package density for data/address lines.

The open collector drivers generate precise trapezoidal waveforms, which are relatively independent of capacitive loading conditions on the outputs. This significantly reduces noise coupling to adjacent lines. In addition, the receivers use a low pass filter in conjunction with a high speed comparator, to further enhance the noise immunity and provide equal rejection to both negative and positive going noise pulses on the bus.

To minimize bus loading, these devices also feature a schottky diode in series with the open collector output that isolates the driver output capacitance in the disabled state. The output low voltage is typically "1V" and the output high level is intended to be 2V. This is achieved by terminating the bus with a pull up resistor to 2V at both ends. The device can drive an equivalent DC load of 18.5 Ω (or greater) in the above configuration.

These signaling requirements, including a 1 volt signal swing, low output capacitance and precise receiver thresholds are referred to as Bus Transceiver Logic (BTL).



Please be aware that an important notice concerning availability, standard warranty, and use in critical applications of Texas Instruments semiconductor products and disclaimers thereto appears at the end of this data sheet.

Trapezoidal is a trademark of dcl_owner.

All other trademarks are the property of their respective owners.

Logic Diagrams

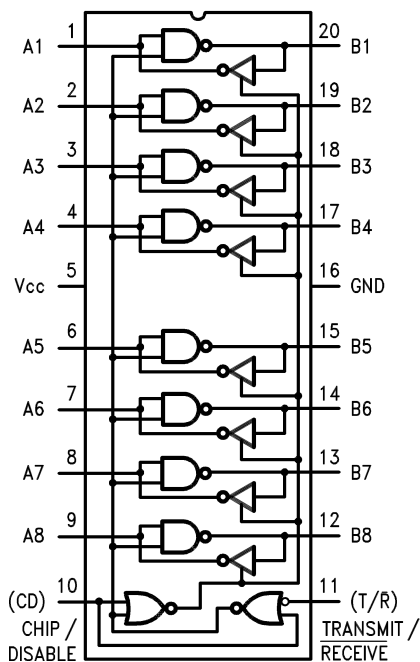

Figure 1. DS3896N, M
See Package Number DW0020B or NFH0020A

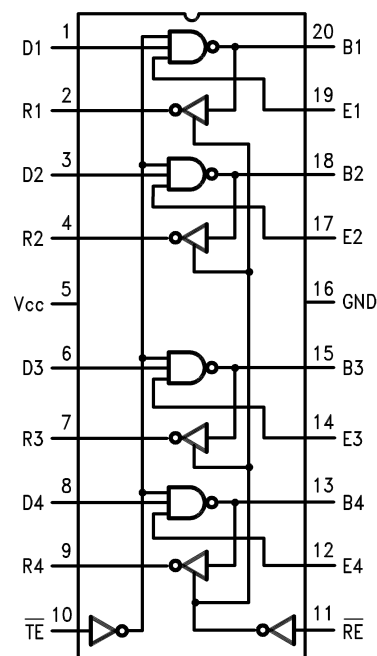

Figure 2. DS3897N, M
See Package Number DW0020B or NFH0020A



These devices have limited built-in ESD protection. The leads should be shorted together or the device placed in conductive foam during storage or handling to prevent electrostatic damage to the MOS gates.

Absolute Maximum Ratings⁽¹⁾⁽²⁾

Supply Voltage	6V
Control Input Voltage	5.5V
Driver Input and Receiver Output	5.5V
Receiver Input and Driver Output	2.5V
Power Dissipation at 70°C N Package	1480 mW
M Package	TBD mW
Storage Temperature Range	-65°C to +150°C
Lead Temperature (Soldering, 4 sec.)	260°C

- (1) "Absolute maximum ratings" are those beyond which the safety of the device cannot be guaranteed. They are not meant to imply that the device should be operated at these limits. The table of "Electrical Characteristic" provide conditions for actual device operation.
 (2) If Military/Aerospace specified devices are required, please contact the TI Sales Office/Distributors for availability and specifications.

Recommended Operating Conditions

	Min	Max	Units
Supply Voltage, V_{CC}	4.75	5.25	V
Bus Termination Voltage	1.90	2.10	V
Operating Free Air Temperature	0	70	°C

Electrical Characteristics:⁽¹⁾⁽²⁾(0°C ≤ T_A ≤ 70°C, 4.75V ≤ V_{CC} ≤ 5.25V unless otherwise specified)

Symbol	Parameter	Conditions	Min	Typ	Max	Units
Driver and Control Inputs: (An, Dn, En, CD, T/R, RE, TE)						
V _{IH}	Logical "1" Input Voltage		2.0			V
V _{IL}	Logical "0" Input Voltage				0.8	V
I _I	Logical "1" Input Current	An = Dn = En = V _{CC}			1	mA
I _{IH}	Logical "1" Input Current	An = Dn = En = 2.4V			40	μA
I _{IHC}	Logical "1" Input Current	CD = T/R = RE = TE = 2.4V			80	μA
I _{IL}	Logical "0" Input Current	An = Dn = En = 0.4V		-1	-1.6	mA
I _{ILC}	Logical "0" Input Current	CD = T/R = RE = TE = 0.4V		-180	-400	μA
V _{CL}	Input Diode Clamp Voltage	I _{clamp} = -12 mA		-0.9	-1.5	V
Driver Output/Receiver Input: (Bn)						
V _{OLB}	Low Level Bus Voltage	An = Dn = En = T/R = 2V, VL = 2V	0.75	1.0	1.2	V
		RL = 18.5Ω, CD = TE = 0.8V (Figure 3)				
I _{IHB}	Maximum Bus Current (Power On)	An = Dn = En = 0.8V, V _{CC} = 5.25V		10	100	μA
		Bn = 2V				
I _{ILB}	Maximum Bus Current (Power Off)	An = Dn = En = 0.8V, V _{CC} = 0V			100	μA
		Bn = 2V				
V _{TH}	Receiver Input Threshold	V _{CC} = 5V	1.47	1.55	1.62	V
Receiver Output: (An, Rn)						
V _{OH}	Logical "1" Output Voltage	Bn = 1.2V, I _{OH} = -400 μA	2.4	3.2		V
		CD = T/R = RE = 0.8V				
V _{OL}	Logical "0" Output Voltage	Bn = 2V, I _{OL} = 16 mA		0.35	0.5	V
		CD = T/R = RE = 0.8V				
I _{OS}	Output Short Circuit Current	Bn = 1.2V	-20	-70	-100	mA
		CD = T/R = RE = 0.8V				
I _{CC}	Supply Current (DS3896)	V _{CC} = 5.25V		90	135	mA
I _{CC}	Supply Current (DS3897)	V _{CC} = 5.25V		50	80	mA

(1) All currents into device pins are positive; all currents out of device pins are negative. All voltages are referenced to device ground unless otherwise specified.

(2) All typicals are given for V_{CC} = 5V and T_a = 25°C.

DS3896 Switching Characteristics⁽¹⁾(0°C ≤ T_A ≤ 70°C, 4.75V ≤ V_{CC} ≤ 5.25V unless otherwise specified)

Symbol	Parameter	Conditions	Min	Typ	Max	Units
Driver:						
t _{DLH}	An to Bn	CD = 0.8V, T/R = 2.0V, VL = 2V	5	9	15	ns
t _{DHL}			(Figure 4)	5	9	15
t _{DLHC}	CD to Bn	An = T/R = 2.0V, VL = 2V	5	10	18	ns
t _{DHLC}			(Figure 4)	5	12	20
t _{DLHT}	T/R to Bn	V _{CI} = An, V _C = 5V, (Figure 7)	5	15	25	ns
t _{DHLT}			CD = 0.8V, RC = 390Ω, CL = 30 pF	5	22	35
		RL1 = 18Ω, RL2 = NC, VL = 2V				
t _R	Driver Output Rise Time	CD = 0.8V, T/R = 2V, VL = 2V	3	6	10	ns
t _F	Driver Output Fall Time	(Figure 4)	3	6	10	ns
Receiver:						
t _{RLH}	Bn to An	CD = 0.8V, T/R = 0.8V	5	12	18	ns
t _{RHL}			(Figure 5)	5	10	18

(1) **Note:** NC means open

DS3896 Switching Characteristics⁽¹⁾ (continued)

(0°C ≤ T_A ≤ 70°C, 4.75V ≤ V_{CC} ≤ 5.25V unless otherwise specified)

Symbol	Parameter	Conditions	Min	Typ	Max	Units
Driver:						
t _{RLZC}	CD to An	Bn = 2.0V, T/ \bar{R} = 0.8V, CL = 5 pF	5	10	18	ns
		RL1 = 390Ω, RL2 = NC, VL = 5V (Figure 6)				
t _{RZLC}		Bn = 2.0V, T/ \bar{R} = 0.8V, CL = 30 pF	5	8	15	ns
		RL1 = 390Ω, RL2 = 1.6k, VL = 5V (Figure 6)				
t _{RHZC}		Bn = 0.8V, T/ \bar{R} = 0.8V, VL = 0V,	2	4	8	ns
		RL1 = 390Ω, RL2 = NC, CL = 5 pF (Figure 6)				
t _{RZHC}		Bn = 0.8V, T/ \bar{R} = 0.8V, VL = 0V,	3	7	12	ns
		RL1 = NC, RL2 = 1.6k, CL = 30 pF (Figure 6)				
t _{RLZT}	T/ \bar{R} to An	VCI = Bn, VC = 2V, RC = 18Ω,	5	10	18	ns
		CD = 0.8V, VL = 5V, RL1 = 390Ω,				
		RL2 = NC, CL = 5 pF (Figure 7)				
t _{RZLT}		VCI = Bn, VC = 2V, RC = 18Ω,	14	24	40	ns
		CD = 0.8V, VL = 5V, RL1 = 390Ω,				
		RL2 = 1.6k, CL = 30 pF (Figure 7)				
t _{RHZT}		VCI = Bn, VC = 0V, RC = 18Ω,	2	4	8	ns
		CD = 0.8V, VL = 0V, RL1 = 390Ω,				
		RL2 = NC, CL = 5 pF (Figure 7)				
t _{RZHT}		VCI = Bn, VC = 0V, RC = 18Ω,	2	8	15	ns
		CD = 0.8V, VL = 0V, RL1 = NC				
		RL2 = 1.6k, CL = 30 pF (Figure 7)				
t _{NR}	Receiver Noise	(Figure 8)	3	6		ns
	Rejection Pulse Width					

DS3897 Switching Characteristics⁽¹⁾

(0°C ≤ T_A ≤ 70°C, 4.75V ≤ V_{CC} ≤ 5.25V unless otherwise specified)

Symbol	Parameter	Conditions	Min	Typ	Max	Units
Driver:						
t _{DLH}	Dn, En to Bn	$\bar{T}\bar{E}$ = 0.8V, $\bar{R}\bar{E}$ = 2.0V, VL = 2V	5	9	15	ns
t _{DHL}		(Figure 4)	5	9	15	ns
t _{DLHT}	$\bar{T}\bar{E}$ to Bn	An = $\bar{R}\bar{E}$ = 2.0V, VL = 2V, (Figure 4)	5	10	18	ns
t _{DHLT}		RC = 390Ω, VCI = An, VC = 5V, CL = 30 pF	5	12	20	ns
		RL1 = 18Ω, RL2 = NC, VL = 2V (Figure 7)				
t _R	Driver Output Rise Time	CD = 0.8V, T/ \bar{R} = 2V, VL = 2V	3	6	10	ns
t _F	Driver Output Fall Time	(Figure 4)	3	6	10	ns
Receiver:						
t _{RLH}	Bn to Rn	$\bar{T}\bar{E}$ = 2.0V, $\bar{R}\bar{E}$ = 0.8V (Figure 5)	5	10	18	ns
t _{RHL}				5	12	18
t _{RLZR}	$\bar{R}\bar{E}$ to Rn	Bn = $\bar{T}\bar{E}$ = 2V, VL = 5V, CL = 5 pF	5	10	18	ns
		RL1 = 390Ω, RL2 = NC (Figure 6)				
t _{RZLR}		Bn = $\bar{T}\bar{E}$ = 2V, VL = 5V, CL = 30 pF	5	8	15	ns
		RL1 = 390Ω, RL2 = 1.6k (Figure 6)				
t _{RHZR}		Bn = 0.8V, $\bar{T}\bar{E}$ = 2V, VL = 0V,	2	4	8	ns
		RL1 = 390Ω, RL2 = NC, CL = 5 pF (Figure 6)				

(1) **Note:** NC means open

DS3897 Switching Characteristics⁽¹⁾ (continued)

(0°C ≤ T_A ≤ 70°C, 4.75V ≤ V_{CC} ≤ 5.25V unless otherwise specified)

Symbol	Parameter	Conditions	Min	Typ	Max	Units
t _{RZHR}		B _n = 0.8V, \overline{TE} = 2V, V _L = 0V, RL1 = NC, RL2 = 1.6k, CL = 30 pF (Figure 6)	3	7	12	ns
t _{NR}	Receiver Noise	(Figure 8)	3	6		ns
	Rejection Pulse Width					
Driver plus Receiver:						
t _{DRLH}	Dn to Rn	\overline{TE} = \overline{RE} = 0.8V (Figure 9)	10	20	30	ns
t _{DRHL}			10	20	30	ns

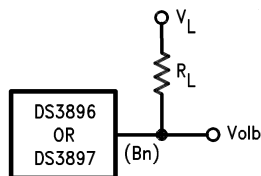
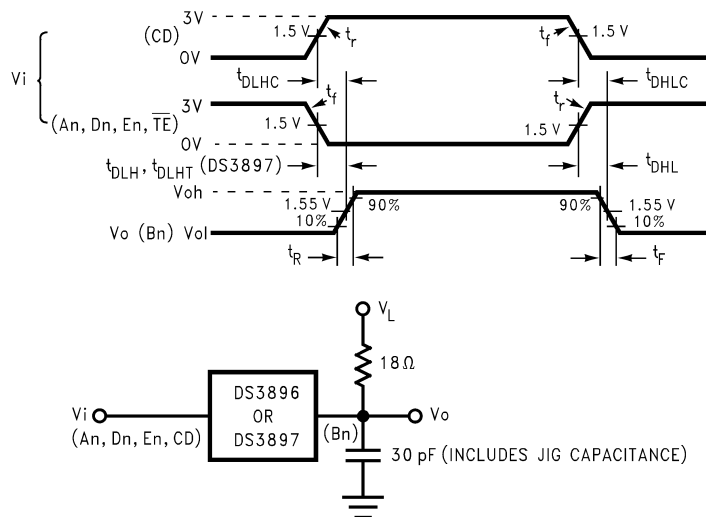
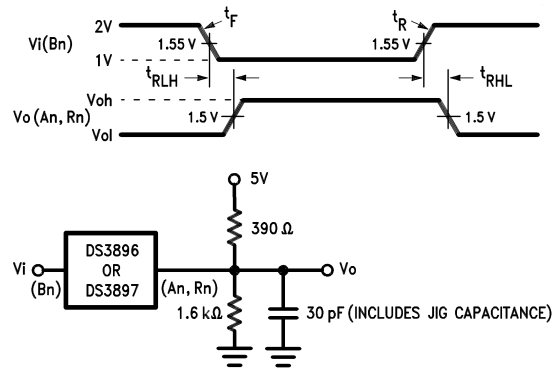

Figure 3. Driver Output Low Voltage Test



Note: t_r = t_f ≤ 5 ns from 10% to 90%

Figure 4. Driver Propagation Delays



Note: $t_R = t_F \leq 10$ ns from 10% to 90%

Figure 5. Receiver Propagation Delays

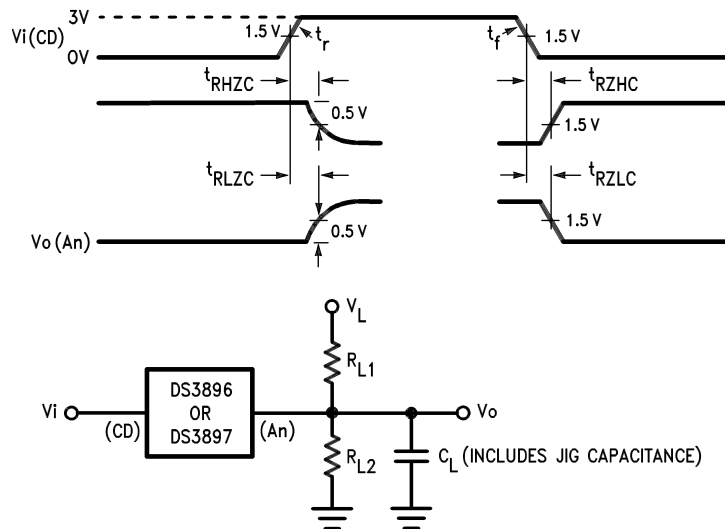

Note: $t_r = t_f \leq 5$ ns from 10% to 90%

Figure 6. Propagation Delay from CD pin to An

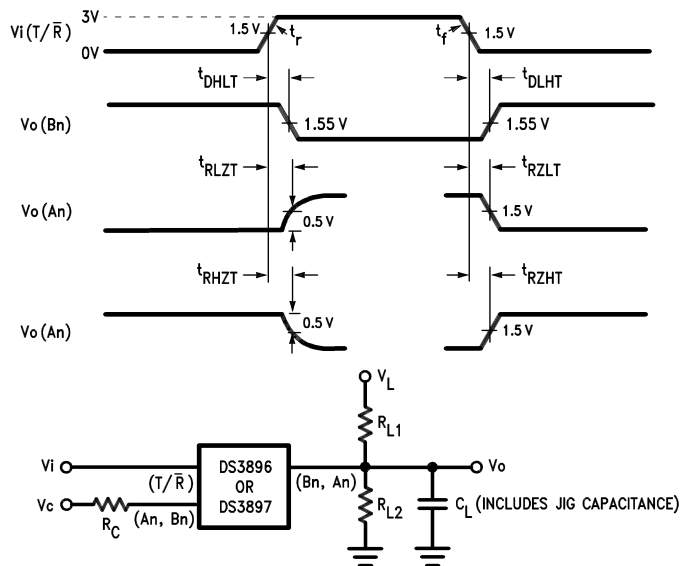

Note: $t_r = t_f \leq 5$ ns from 10% to 90%

Figure 7. Propagation Delay from T/R pin to An or Bn

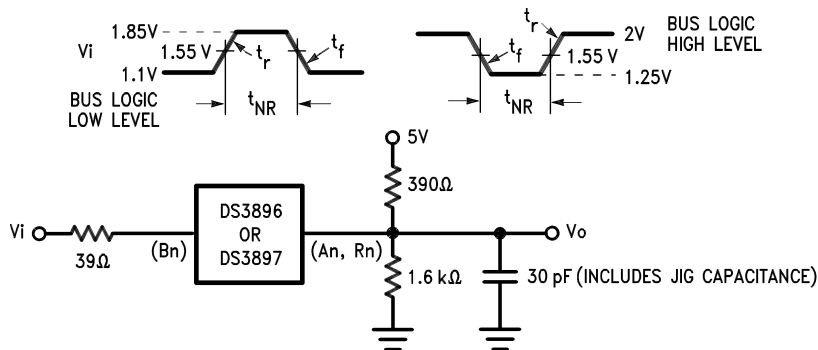

Note: $t_r = t_f = 2$ ns from 10% to 90%

Figure 8. Receiver Noise Immunity: “No Response at Output” Input Waveforms

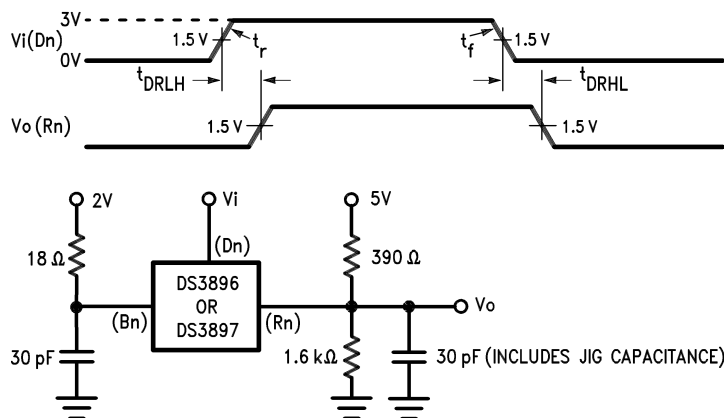

Note: $t_r = t_f \leq 5$ ns from 10% to 90%

Figure 9. Driver Plus Receiver Delays

TYPICAL APPLICATION

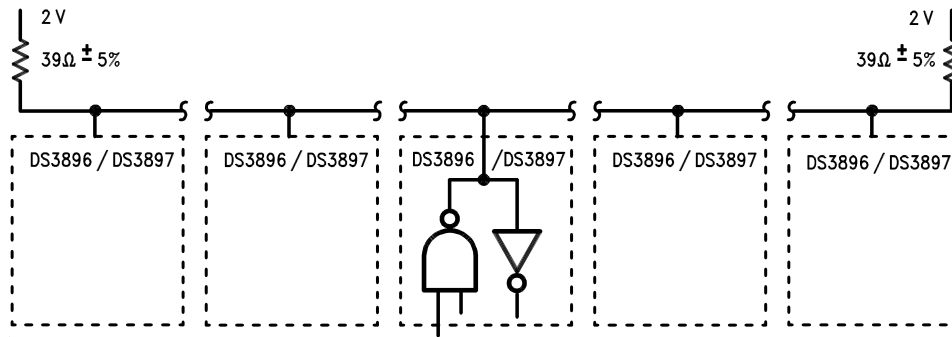

REVISION HISTORY

Changes from Revision C (February 2013) to Revision D	Page
<hr/> <ul style="list-style-type: none">• Changed layout of National Data Sheet to TI format	<hr/> 8

IMPORTANT NOTICE

Texas Instruments Incorporated and its subsidiaries (TI) reserve the right to make corrections, enhancements, improvements and other changes to its semiconductor products and services per JESD46, latest issue, and to discontinue any product or service per JESD48, latest issue. Buyers should obtain the latest relevant information before placing orders and should verify that such information is current and complete. All semiconductor products (also referred to herein as "components") are sold subject to TI's terms and conditions of sale supplied at the time of order acknowledgment.

TI warrants performance of its components to the specifications applicable at the time of sale, in accordance with the warranty in TI's terms and conditions of sale of semiconductor products. Testing and other quality control techniques are used to the extent TI deems necessary to support this warranty. Except where mandated by applicable law, testing of all parameters of each component is not necessarily performed.

TI assumes no liability for applications assistance or the design of Buyers' products. Buyers are responsible for their products and applications using TI components. To minimize the risks associated with Buyers' products and applications, Buyers should provide adequate design and operating safeguards.

TI does not warrant or represent that any license, either express or implied, is granted under any patent right, copyright, mask work right, or other intellectual property right relating to any combination, machine, or process in which TI components or services are used. Information published by TI regarding third-party products or services does not constitute a license to use such products or services or a warranty or endorsement thereof. Use of such information may require a license from a third party under the patents or other intellectual property of the third party, or a license from TI under the patents or other intellectual property of TI.

Reproduction of significant portions of TI information in TI data books or data sheets is permissible only if reproduction is without alteration and is accompanied by all associated warranties, conditions, limitations, and notices. TI is not responsible or liable for such altered documentation. Information of third parties may be subject to additional restrictions.

Resale of TI components or services with statements different from or beyond the parameters stated by TI for that component or service voids all express and any implied warranties for the associated TI component or service and is an unfair and deceptive business practice. TI is not responsible or liable for any such statements.

Buyer acknowledges and agrees that it is solely responsible for compliance with all legal, regulatory and safety-related requirements concerning its products, and any use of TI components in its applications, notwithstanding any applications-related information or support that may be provided by TI. Buyer represents and agrees that it has all the necessary expertise to create and implement safeguards which anticipate dangerous consequences of failures, monitor failures and their consequences, lessen the likelihood of failures that might cause harm and take appropriate remedial actions. Buyer will fully indemnify TI and its representatives against any damages arising out of the use of any TI components in safety-critical applications.

In some cases, TI components may be promoted specifically to facilitate safety-related applications. With such components, TI's goal is to help enable customers to design and create their own end-product solutions that meet applicable functional safety standards and requirements. Nonetheless, such components are subject to these terms.

No TI components are authorized for use in FDA Class III (or similar life-critical medical equipment) unless authorized officers of the parties have executed a special agreement specifically governing such use.

Only those TI components which TI has specifically designated as military grade or "enhanced plastic" are designed and intended for use in military/aerospace applications or environments. Buyer acknowledges and agrees that any military or aerospace use of TI components which have **not** been so designated is solely at the Buyer's risk, and that Buyer is solely responsible for compliance with all legal and regulatory requirements in connection with such use.

TI has specifically designated certain components as meeting ISO/TS16949 requirements, mainly for automotive use. In any case of use of non-designated products, TI will not be responsible for any failure to meet ISO/TS16949.

Products

Audio	www.ti.com/audio
Amplifiers	amplifier.ti.com
Data Converters	dataconverter.ti.com
DLP® Products	www.dlp.com
DSP	dsp.ti.com
Clocks and Timers	www.ti.com/clocks
Interface	interface.ti.com
Logic	logic.ti.com
Power Mgmt	power.ti.com
Microcontrollers	microcontroller.ti.com
RFID	www.ti-rfid.com
OMAP Applications Processors	www.ti.com/omap
Wireless Connectivity	www.ti.com/wirelessconnectivity

Applications

Automotive and Transportation	www.ti.com/automotive
Communications and Telecom	www.ti.com/communications
Computers and Peripherals	www.ti.com/computers
Consumer Electronics	www.ti.com/consumer-apps
Energy and Lighting	www.ti.com/energy
Industrial	www.ti.com/industrial
Medical	www.ti.com/medical
Security	www.ti.com/security
Space, Avionics and Defense	www.ti.com/space-avionics-defense
Video and Imaging	www.ti.com/video

TI E2E Community

e2e.ti.com

Looking for pricing, stock, or lifecycle information?

Click below to explore more details on WIN SOURCE:

 [View DS3896M](#) on WIN SOURCE

 [Texas Instruments](#) Information

Optimize Your Supply Chain with WIN SOURCE Solutions

-  Global Sourcing Solution
-  Obsolete Management
-  Cost Control Management
-  Shortage Management
-  Alternative Solution
-  Excess Inventory Management