

Click [here](#) to ask about the production status of specific part numbers.

MAX30208

$\pm 0.1^{\circ}\text{C}$ Accurate, I²C Digital Temperature Sensor

General Description

The MAX30208 operates from a 1.7V to 3.6V supply voltage, and is a low-power, high-accuracy digital temperature sensor with $\pm 0.1^{\circ}\text{C}$ accuracy from $+30^{\circ}\text{C}$ to $+50^{\circ}\text{C}$ and $\pm 0.15^{\circ}\text{C}$ accuracy from 0°C to $+70^{\circ}\text{C}$. The MAX30208 has 16-bit resolution (0.005°C).

The device uses a standard I²C serial interface to communicate with a host controller. Two GPIO pins are available. GPIO1 can be configured to trigger a temperature conversion, while GPIO0 can be configured to generate an interrupt for selectable status bits.

The MAX30208 includes a 32-word FIFO for the temperature data and also includes high and low threshold digital temperature alarms. The device is available in a 2mm x 2mm x 0.75mm, 10-pin Thin LGA package.

Applications

- Wearable Body Temperature Monitors
- Medical Thermometers
- Internet of Things (IoT) Sensors

Benefits and Features

- High Accuracy and Precision
 - $\pm 0.1^{\circ}\text{C}$ Accuracy from $+30^{\circ}\text{C}$ to $+50^{\circ}\text{C}$
 - $\pm 0.15^{\circ}\text{C}$ Accuracy from $+0^{\circ}\text{C}$ to $+70^{\circ}\text{C}$
- Low Power Consumption
 - 1.7V to 3.6V Operating Voltage
 - 67 μA Operating Current During Measurement
 - 0.5 μA Standby Current
 - 15ms Integration Time
- Small Size
 - 2mm x 2mm x 0.75mm, 10-Pin Thin LGA
- Safety and Compliance
 - High and Low Temperature Alarms
- Digital Interface
 - Configurable Convert Temperature Input Pin
 - Configurable Interrupt Output Pin
 - 32-Word FIFO for Temperature Data
 - 4 I²C Addresses Available—More Addresses Available by Request
 - Unique ROM IDs Allow Device to be NIST Traceable

Ordering Information appears at end of data sheet.

Simplified Block Diagram

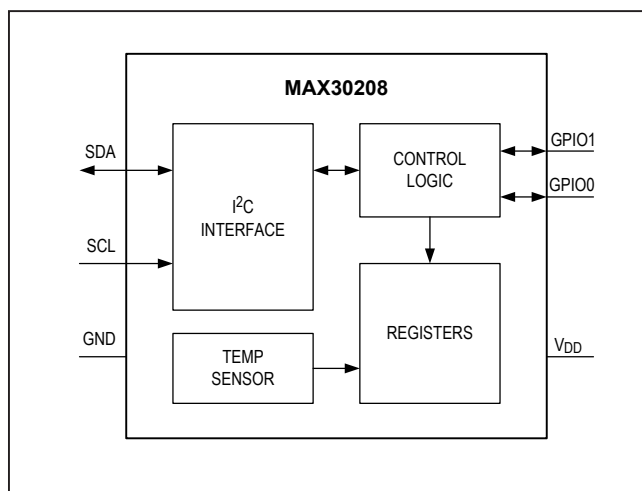

Accuracy Error vs. Temperature

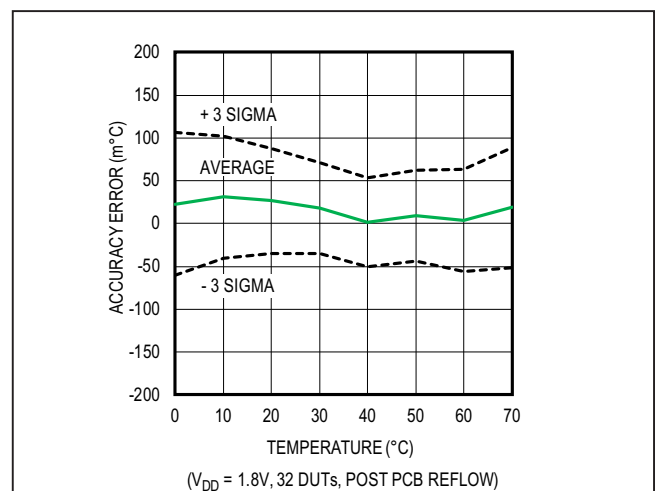

Absolute Maximum Ratings

V _{DD} to GND	-0.3V to +6V	Operating Temperature Range.....	0°C to 70°C
GPIO0 to GND	-0.3V to +6V	Junction Temperature.....	+150°C
GPIO1 to GND	-0.3V to V _{DD}	Storage Temperature Range.....	-55°C to +125°C
SDA,SCL to GND	-0.3V to +6V	Lead Temperature (soldering, 10s)	+220°C
		Soldering Temperature (reflow).....	+220°C

Stresses beyond those listed under "Absolute Maximum Ratings" may cause permanent damage to the device. These are stress ratings only, and functional operation of the device at these or any other conditions beyond those indicated in the operational sections of the specifications is not implied. Exposure to absolute maximum rating conditions for extended periods may affect device reliability.

Package Information

PACKAGE TYPE: 10-PIN THIN LGA	
Package Code	L1022+2
Outline Number	21-100265
Land Pattern Number	90-100101
THERMAL RESISTANCE, SINGLE-LAYER BOARD:	
Junction to Ambient (θ _{JA})	241.30°C/W
Junction to Case (θ _{JC})	53.90°C/W

For the latest package outline information and land patterns (footprints), go to www.maximintegrated.com/packages. Note that a "+", "#", or "-" in the package code indicates RoHS status only. Package drawings may show a different suffix character, but the drawing pertains to the package regardless of RoHS status.

Package thermal resistances were obtained using the method described in JEDEC specification JESD51-7, using a four-layer board. For detailed information on package thermal considerations, refer to www.maximintegrated.com/thermal-tutorial.

Electrical Characteristics

(V_{DD} = 1.8V, T_A = 25°C, min/max are from T_A = 0°C to +70°C, unless otherwise noted.) (Note 1)

PARAMETER	SYMBOL	CONDITIONS		MIN	TYP	MAX	UNITS
TEMPERATURE SENSOR							
Temperature Measurement Error		+30°C to +50°C	post reflow, 3 sigma	-0.1		+0.1	°C
			post reflow, 6 sigma	-0.2		+0.2	
		+0°C to +70°C	post reflow, 6 sigma	-0.3		+0.3	
Resolution		16-Bit			0.005		°C
Repeatability		V _{DD} = 1.8V, 1sps, 120 samples			0.008		°C RMS
Response Time		T _A = +0°C to +50°C	Unmounted, 63% (Note 2)		0.5		s
			Mounted, 63% (Note 2)		3.5		
Long Term Stability		Mounted, T _A = 70°C, 0% RH			0.015		°C/1000hrs
Supply Voltage	V _{DD}	Guaranteed by PSRR		1.7		3.6	V
DC Power Supply Rejection Ratio	PSRR	T _A = +25°C			0.006		°C/V

Electrical Characteristics (continued)

(V_{DD} = 1.8V, T_A = 25°C, min/max are from T_A = 0°C to +70°C, unless otherwise noted.) (Note 1)

PARAMETER	SYMBOL	CONDITIONS	MIN	TYP	MAX	UNITS
Operating Current		During Conversion	V _{DD} = 3.6V	68	100	μA
			V _{DD} = 1.8V	67	100	
Standby Current		V _{DD} = 3.6V, T _A = +25°C		0.5	1.0	μA
		V _{DD} = 3.6V, T _A = +70°C		0.7	3	
GPIO PINS						
Input Voltage Low	V _{IL_GPIO}				0.4	V
Input Voltage High	V _{IH_GPIO}		1.4			V
Input Hysteresis	V _{HYS_GPIO}			320		mV
Input Leakage Current	I _{IN_GPIO}	V _{IN} = 0V, T _A = +25°C		0.01	1	μA
Input Capacitance	C _{IN_GPIO}			10		pF
Input Low Pulse Width			5			μS
Output Low Voltage	V _{OL_GPIO}	I _{SINK} = 2mA			0.4	V
I²C / DIGITAL I/O CHARACTERISTICS						
Input Voltage Low	V _{IL}				0.4	V
Input Voltage High	V _{IH}		1.4			V
Input Hysteresis	V _{HYS}			200		mV
Input Capacitance	C _{IN}			10		pF
Open Drain Output Low Voltage	V _{OL_OD}	I _{SINK} = 6mA, SDA Pin Only			0.4	V
I²C / TIMING CHARACTERISTICS (Note 3)						
I ² C Write Address		GPIO1 = GPIO0 = 0V. See Table 3		A0		Hex
I ² C Read Address		GPIO1 = GPIO0 = 0V. See Table 3		A1		Hex
Serial Clock Frequency	f _{SCL}		0		400	kHz
Bus Free Time Between STOP and START Conditions	t _{BUF}		1.3			μs
Hold Time START and Repeat START Condition	t _{HD,STA}		0.6			μs
SCL Pulse-Width Low	t _{LOW}		1.3			μs
SCL Pulse-Width High	t _{HIGH}		0.6			μs
Setup Time for a Repeated START Condition	t _{SU_STA}		0.6			μs
Data Hold Time	t _{HD_DAT}		0		900	ns
Data Setup Time	t _{SU_DAT}		100			ns

Electrical Characteristics (continued)(V_{DD} = 1.8V, T_A = 25°C, min/max are from T_A = 0°C to +70°C, unless otherwise noted.) (Note 1)

PARAMETER	SYMBOL	CONDITIONS	MIN	TYP	MAX	UNITS
Setup Time for STOP Condition	t _{SU_STO}		0.6			μs
Pulse Width of Suppressed Spike	t _{SP}				50	ns
Bus Capacitance	C _B				400	pF
SDA and SCL Receiving Rise Time	t _R		20 + 0.1C _B		300	ns
SDA and SCL Receiving Fall Time	t _F		20 + 0.1C _B		300	ns
SDA Transmitting Fall Time	t _{TF}		20 + 0.1C _B		300	ns

Note 1: All devices are 100% production tested at T_A = +25°C. Specifications over temperature limits are guaranteed by Maxim Integrated bench or proprietary automated test equipment (ATE) characterization.

Note 2: Unmounted: Part is on single-layer flex PCB.
Mounted: Part is on a 2-layer PCB.

Note 3: For design guidance only. Not production tested.

Typical Operating Characteristics

(V_{DD} = +1.8V, T_A = 25°C, unless otherwise noted.)

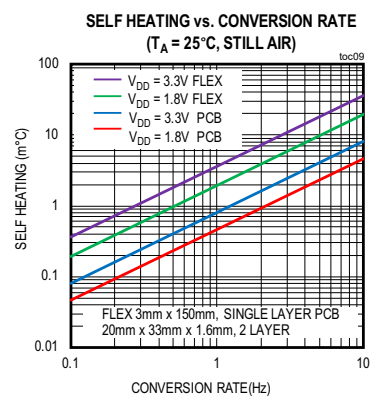
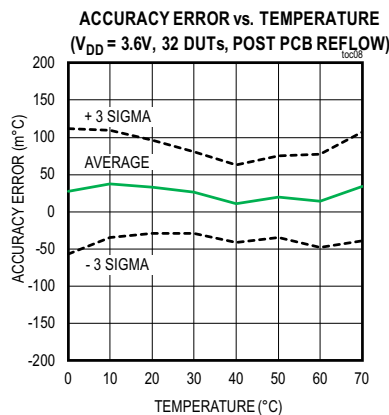
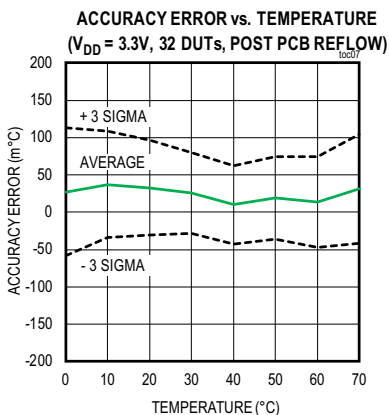
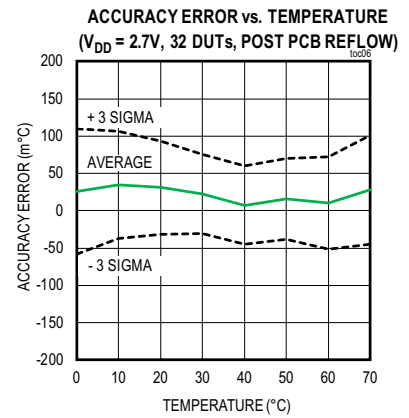
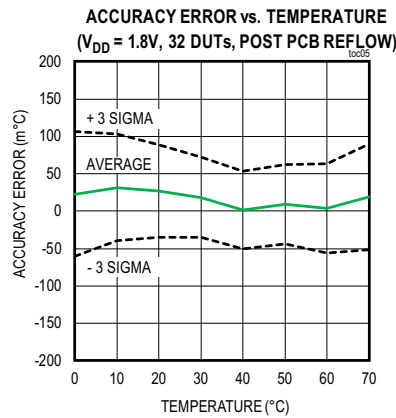
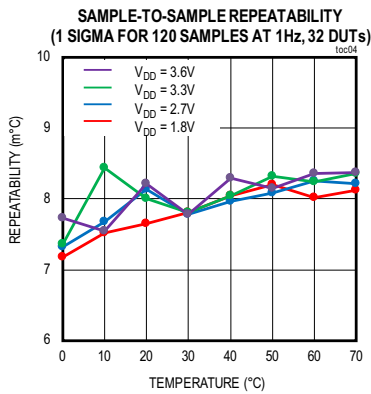
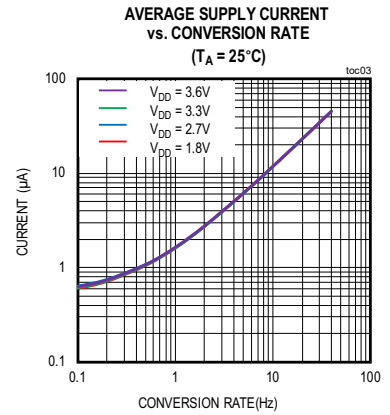
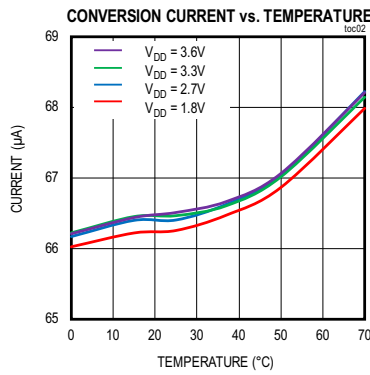
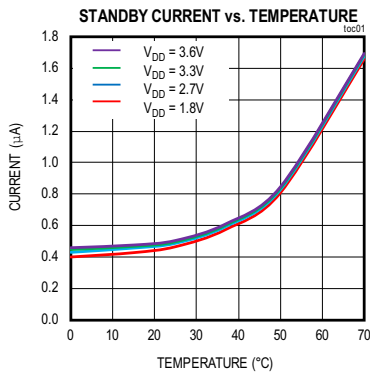

Pin Configuration

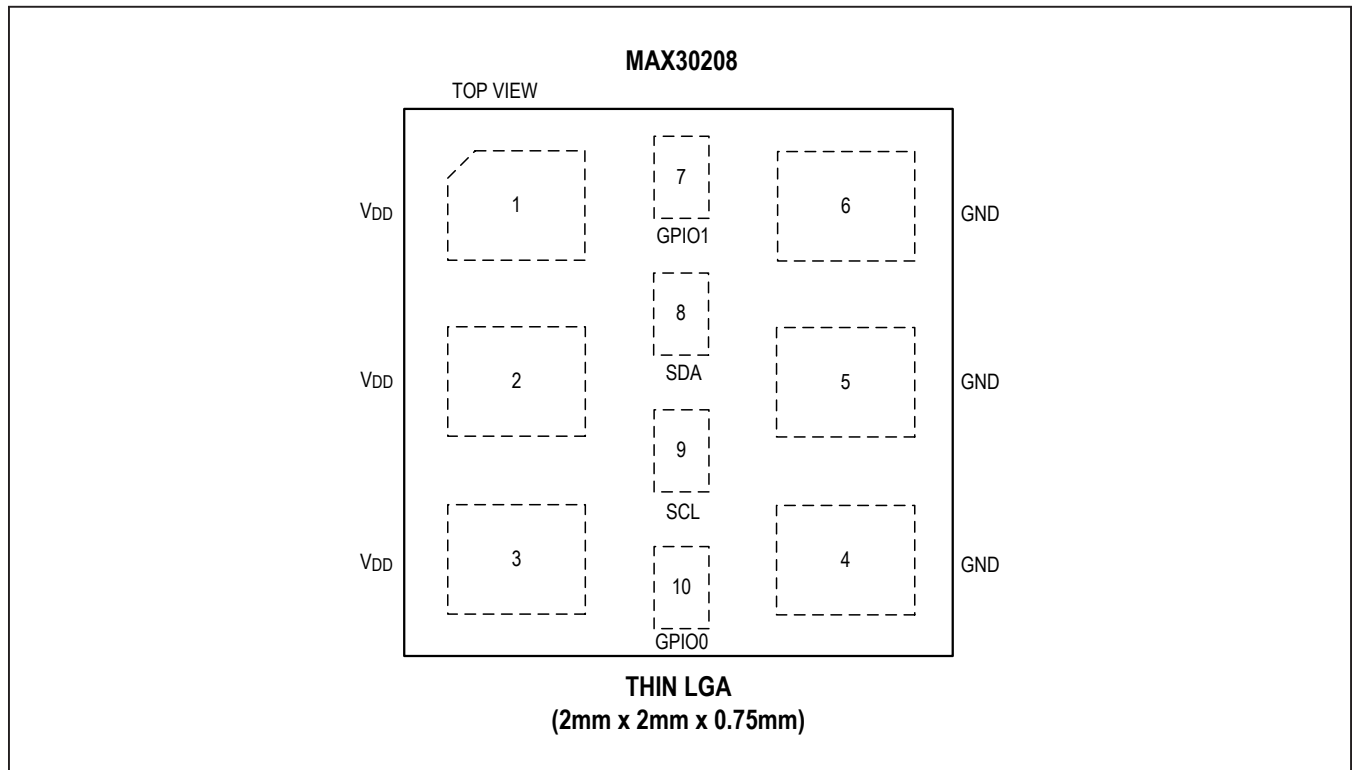

Pin Description

PIN	NAME	FUNCTION
Power		
1, 2, 3	V _{DD}	Power. +1.7V to +3.6V. Connect 0.1µF capacitor connected to ground.
4, 5, 6	GND	Ground Reference.
I²C		
8	SDA	I ² C Data Input and Output
9	SCL	I ² C Clock
GPIO		
7	GPIO1	General Purpose Input/Output 1. State at each I ² C start condition can be used to configure I ² C addresses, see Table 2 & Table 3 . Can be configured to act as an external temperature convert input.
10	GPIO0	General Purpose Input/Output 0. State at each I ² C start condition can be used to configure I ² C addresses, see Table 2 & Table 3 . Can be configured as an interrupt output.

Functional Diagram

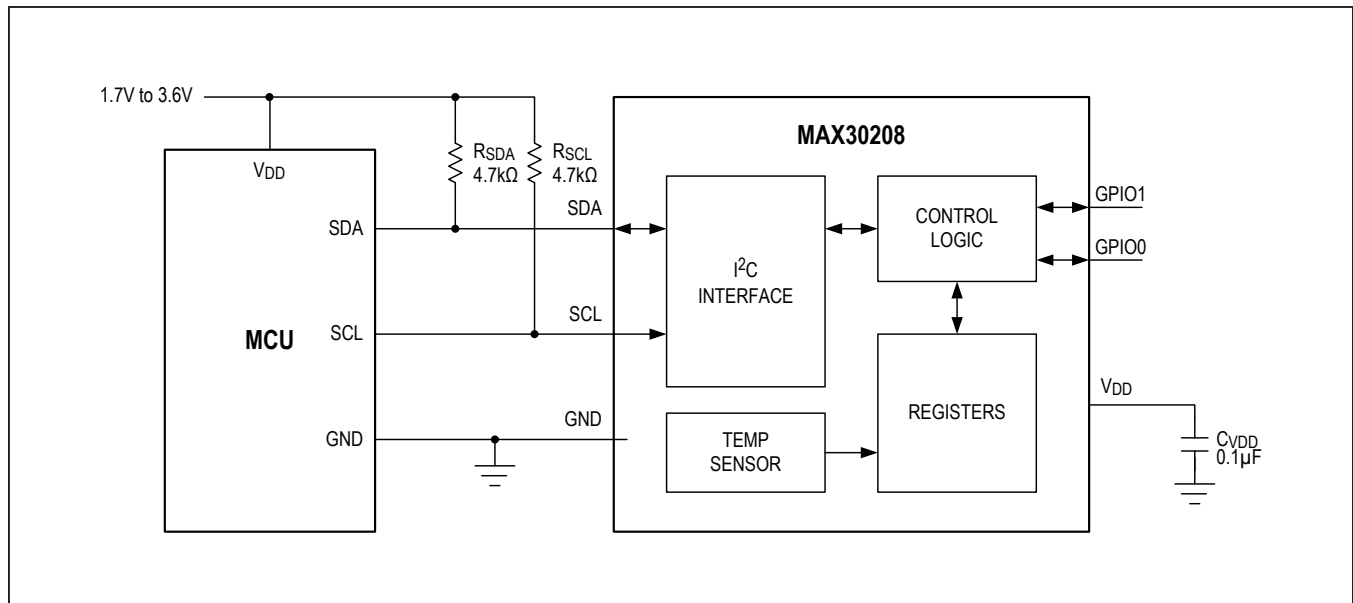

Detailed Description

The MAX30208 temperature sensor measures temperature with $\pm 0.1^{\circ}\text{C}$ accuracy over a $+30^{\circ}\text{C}$ to $+50^{\circ}\text{C}$ temperature range and $\pm 0.15^{\circ}\text{C}$ accuracy over a 0°C to $+70^{\circ}\text{C}$ temperature range. The device communicates over a standard I²C interface with serial data (SDA) and serial clock (SCL) lines to read the FIFO, which contains up to 32, 2-byte temperature readings. The device operates properly over a -40°C to $+85^{\circ}\text{C}$ temperature range without any damage.

In addition to the FIFO, the memory mapped registers contain high-alarm and low-alarm trigger registers and a temperature sensor setup register. The temperature sensor provides a 16-bit ADC. The Alarm High, Alarm Low, and Setup registers are volatile, and do not retain data when the device is powered down.

The MAX30208 has two GPIO pins. The default state of the GPIO pins at powerup determines the 2 LSBs in the I²C address of the device. GPIO1 allows for an optional external convert temperature trigger while GPIO0 can be configured as an interrupt for selectable status bits.

Operation

Measurement Considerations

Key parameters affecting the performance of temperature sensors are the thermal conductivity from the IC to the board and from the IC to the air. A conventional surface-mount temperature sensor IC has high thermal conductivity to the circuit board on which it is mounted. Heat travels from the board through the package leads to the sensor die. Although air temperature also affects die temperature, the sensor plastic package does not conduct heat as well as its leads. Therefore, board temperature has a greater influence on the measured temperature.

- Place the sensor as close as possible to the target temperature to be measured and create a good thermal contact with the top of the package.
- Use traces that are as thin as possible to minimize the thermal conduction away from the sensor.
- Best results are obtained when the device is mounted on a flexible kapton PCB.

Measuring Temperature

The device powers up in a low-power standby state. To initiate a temperature measurement the master must write a '1' to the CONVERT_T bit in the TEMP_SENSOR_SETUP[0x14] register. Do not sample at more than 20Hz, as the total time for a sample to be ready after sending a conversion command can be up to 50ms. Following the conversion, which takes 15ms(typ), the resulting temperature data is store in the FIFO and the device returns to the standby state. CONVERT_T automatically clears to '0.'

The output temperature data is calibrated in degrees Celsius. The temperature data is stored as a left-justified, 16-bit sign-extended two's complement number in the

FIFO Data register (see [Figure 1](#)). The data is two's complement where the MSB determines the sign of the temperature with an MSB of 1 indicating a negative temperature and an MSB of 0 indicating a positive temperature.

To calculate the temperature from the measurement result, convert the two's complement value to the decimal value and use the following equation for all bit resolutions.

$$T = \text{Decimal Value} \times 0.005$$

For example, if the result is 0x1CE8, convert to decimal to get 7400, then $T = 7400 \times 0.005$ or 37°C. [Table 1](#) gives examples of digital output data and the corresponding temperature reading.

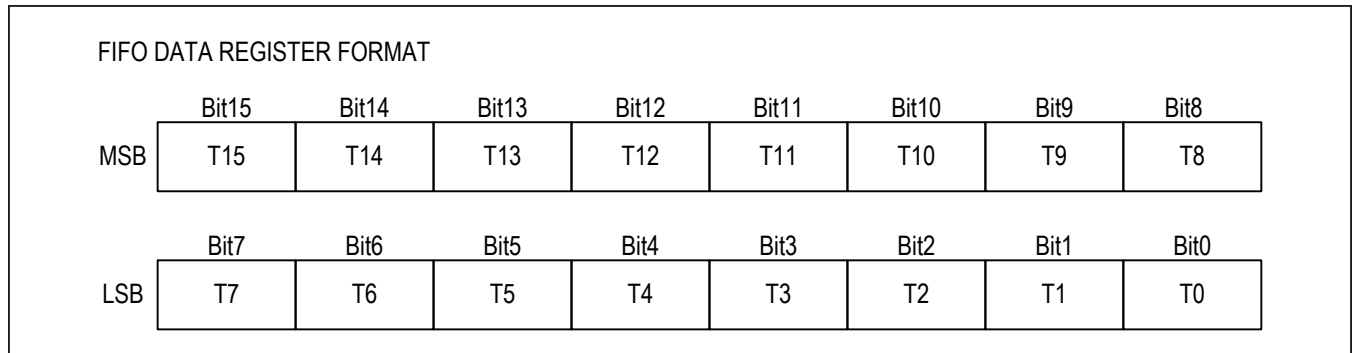

Figure 1. Temperature Data Register Format

Table 1. FIFO Data Format

TEMPERATURE (°C)	DIGITAL OUTPUT (BINARY)	DIGITAL OUTPUT (HEXADECIMAL)	DIGITAL OUTPUT (DECIMAL)
+70	0011 0110 1011 0000	36B0	14,000
+50	0010 0111 0001 0000	2710	10,000
+41	0010 0000 0000 1000	2008	8,200
+37	0001 1100 1110 1000	1CE8	7,400
+35.8	0001 1011 1111 1000	1BF8	7,160
+25	0001 0011 1000 1000	1388	5,000
+15	0000 1011 1011 1000	0BB8	3,000
+0.04	0000 0000 0000 1000	0008	8
+0.02	0000 0000 0000 0100	0004	4
+0.01	0000 0000 0000 0010	0002	2
+0.005	0000 0000 0000 0001	0001	1
0	0000 0000 0000 0000	0000	0

Alarm Signaling

After the device performs a temperature conversion, the temperature value is compared with the user-defined two's complement alarm trigger values stored in the 2-byte Alarm High and 2-byte Alarm Low registers (see [Figure 2](#)). The default value for AH is 0x7FFF (+163.835°C) and the default value for AL is 0x8000 (-163.840°C). The MSB indicates if the value is positive or negative; for positive numbers the MSB is 0 and for negative numbers the MSB is 1. The alarm high threshold, AH is programmed in registers ALARM_HI_MSB [0x10] and ALARM_HI_LSB [0x11]. The alarm low threshold, AL is programmed in registers ALARM_LO_MSB [0x12] and ALARM_LO_LSB [0x13].

If the measured temperature is lower than AL or higher than AH, an alarm condition exists and corresponding

status bit, TEMP_LO or TEMP_HI is set in the STATUS [0x00] register. When the alarm condition is detected and the corresponding interrupt enable bit, TEMP_LO_EN or TEMP_HI_EN is set in the INTERRUPT_ENABLE [0x01] register and if GPIO0_MODE in the GPIO_SETUP [0x20] register is set to 0x3 then a hardware interrupt asserts on the GPIO0 pin. The status bits, the alarm flag and the hardware interrupt stay asserted until the STATUS [0x00] register is read using the serial interface. The alarm flag only clears when STATUS is read. If the alarm flag is set and the next result does not trip the flag, then the flag remains set.

If the alarm settings change while the device is under an alarm condition, the alarm status must be cleared and another temperature conversion executed to update the alarm condition.

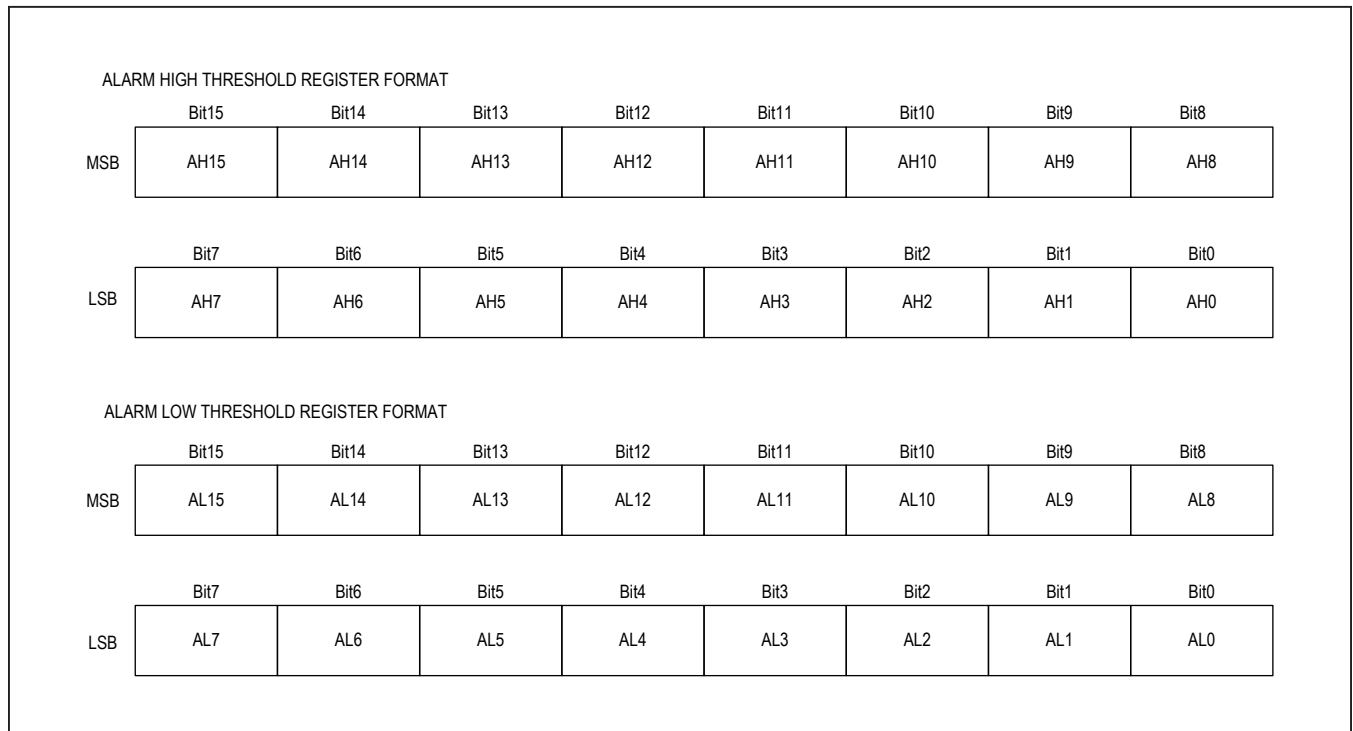

Figure 2. Alarm Threshold Register Format

GPIO

The MAX30208 provides access to two GPIO pins which can be used to provide additional functionality. GPIO0 can be configured to output an interrupt while GPIO1 can be configured as an input for a temperature conversion. The interrupt on GPIO0 is triggered based on selectable status bits in the INTERRUPT_ENABLE[0x01] register. By writing to one of the available bits in the INTERRUPT_ENABLE register, the flag for an interrupt is raised if GPIO0_MODE[1:0] in the GPIO_SETUP [0x20] register is set to 11. When GPIO1_MODE[7:0] in the GPIO_SETUP register is set to 11, driving the line low initiates an external temperature conversion. [Table 2](#) shows a complete list of the functions of the two GPIO Pins.

The state of GPIO pins at each I²C start condition is used to determine the last two bits of the I²C address. This use of the GPIO pins is further detailed below in the [I²C Slave Address](#) section.

I²C

I²C Slave Address

I²C Slave Address is 8 bits as shown in [Table 3](#). Bit 0 is 0 for a write operation and 1 for a read operation.

At powerup, GPIO0 and GPIO1 are set to mode 10 as shown in [Table 3](#). The I²C address is determined by the state of these pins. If the mode of either of the GPIO pins is changed to 01 or 11 then those address pins are automatically pulled low internally and can change the I²C address.

Table 2. GPIO Mode Functions

GPIOX_MODE[1:0] (X = 0, 1)	GPIO0	GPIO1
00	HiZ Input	HiZ Input
01	Output	Output
10 (default)	1MΩ Internal Pulldown Input	1MΩ Internal Pulldown Input
11	INTB	CONV

Table 3. I²C Slave Address

I ² C ADDRESS							W/R	GPIO STATES		CONDITION
7	6	5	4	3	2	1	0	GPIO1_MODE[1:0]	GPIO0_MODE[1:0]	
1	0	1	0	0	GPIO1	GPIO0	0/1	10	10	Default state at powerup
1	0	1	0	0	GPIO1	GPIO0	0/1	00	00	Both GPIO1 and GPIO0 are inputs
1	0	1	0	0	GPIO1	GPIO0	0/1	10	00	Both GPIO1 and GPIO0 are inputs
1	0	1	0	0	GPIO1	GPIO0	0/1	00	10	Both GPIO1 and GPIO0 are inputs
1	0	1	0	0	GPIO1	0	0/1	00	01	GPIO1 is an input, GPIO0 is an output
1	0	1	0	0	GPIO1	0	0/1	00	11	GPIO1 is an input, GPIO0 is an output
1	0	1	0	0	GPIO1	0	0/1	10	01	GPIO1 is an input, GPIO0 is an output
1	0	1	0	0	GPIO1	0	0/1	10	11	GPIO1 is an input, GPIO0 is an output
1	0	1	0	0	0	GPIO0	0/1	01	00	GPIO1 is an output, GPIO0 is an input
1	0	1	0	0	0	GPIO0	0/1	01	10	GPIO1 is an output, GPIO0 is an input
1	0	1	0	0	0	GPIO0	0/1	11	00	GPIO1 is an output, GPIO0 is an input
1	0	1	0	0	0	GPIO0	0/1	11	10	GPIO1 is an output, GPIO0 is an input
1	0	1	0	0	0	0	0/1	01	01	GPIO1 and GPIO0 are outputs
1	0	1	0	0	0	0	0/1	01	11	GPIO1 and GPIO0 are outputs
1	0	1	0	0	0	0	0/1	11	01	GPIO1 and GPIO0 are outputs
1	0	1	0	0	0	0	0/1	11	11	GPIO1 and GPIO0 are outputs

I²C/SMBus Compatible Serial Interface

The MAX30208 features an I²C/SMBus-compatible, 2-wire serial interface consisting of a serial data line (SDA) and a serial clock line (SCL). SDA and SCL facilitate communication between the MAX30208 and the master at clock rates up to 400kHz. Figure 3 shows the 2-wire interface timing diagram. The master generates SCL and initiates data transfer on the bus. The master device writes data to the MAX30208 by transmitting the proper slave address followed by the register address and then the data word. Each transmit sequence is framed by a START (S) or REPEATED START (Sr) condition and a STOP (P) condition. Each word transmitted to the MAX30208 is 8-bits long and is followed by an acknowledge clock pulse. A master reading data from the MAX30208 transmits the proper slave address followed by a series of nine SCL pulses. The MAX30208 transmits data on SDA in sync with the master-generated SCL pulses. The master acknowledges receipt of each byte of data. Each read sequence is framed by a START (S) or REPEATED START (Sr) condition, a not acknowledge, and a STOP (P) condition. SDA operates as both an input and an open-drain output. A pullup resistor is required on SDA. SCL operates only as an input. A pullup resistor is required on SCL if there are multiple masters on

the bus, or if the single master has an open-drain SCL output. Series resistors in line with SDA and SCL are optional. Series resistors protect the digital inputs of the MAX30208 from high voltage spikes on the bus lines, and minimize crosstalk and undershoot of the bus signals.

Detailed I²C Timing Diagram

The detailed timing diagram is shown in Figure 3.

Bit Transfer

One data bit is transferred during each SCL cycle. The data on SDA must remain stable during the high period of the SCL pulse. Changes in SDA while SCL is high are control signals (see the *START and STOP Conditions* section).

START and STOP Conditions

SDA and SCL idle high when the bus is not in use. A master initiates communication by issuing a START condition. A START condition is a high-to-low transition on SDA with SCL high. A STOP condition is a low-to-high transition on SDA while SCL is high (Figure 4). A START condition from the master signals the beginning of a transmission to the MAX30208. The master terminates transmission, and frees the bus, by issuing a STOP condition. The bus remains active if a REPEATED START condition is generated instead of a STOP condition.

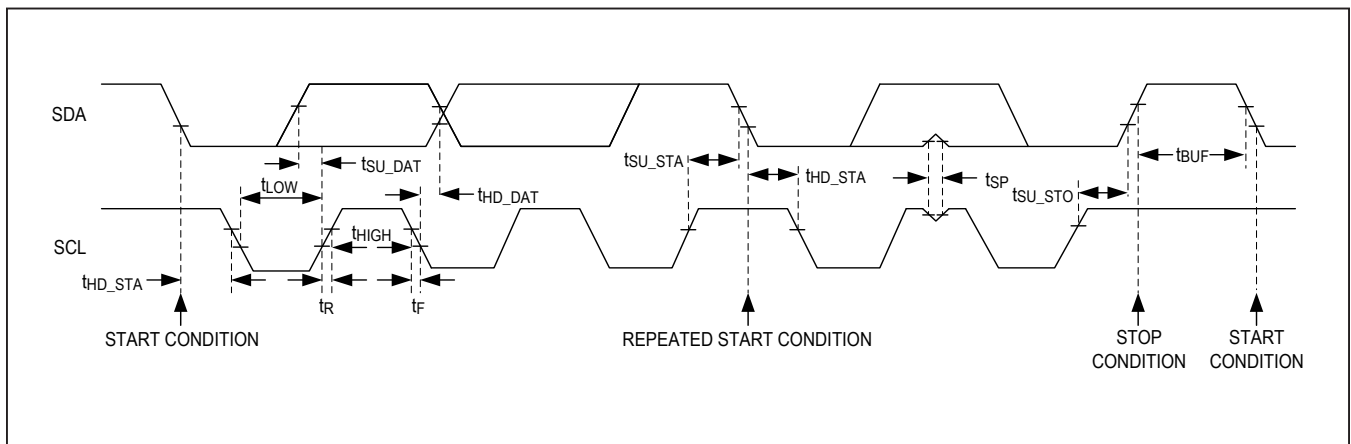

Figure 3. Detailed I²C Timing Diagram

Early STOP Conditions

The MAX30208 recognizes a STOP condition at any point during data transmission except if the STOP condition occurs in the same high pulse as a START condition. For proper operation, do not send a STOP condition during the same SCL high pulse as the START condition.

Acknowledge Bit

The acknowledge bit (ACK) is a clocked 9th bit that the MAX30208 uses to handshake receipt of each byte of data when in write mode [Figure 5](#). The MAX30208 pulls down SDA during the entire master-generated 9th clock pulse if the previous byte is successfully received. Monitoring ACK allows for detection of unsuccessful data transfers. An unsuccessful data transfer occurs if a receiving device is busy or if a system fault has occurred. In the event of an unsuccessful data transfer, the bus master retries communication. The master pulls down SDA during the 9th clock cycle to acknowledge receipt of data when the MAX30208 is in read mode. An acknowledge is sent by

the master after each read byte to allow data transfer to continue. A not-acknowledge is sent when the master reads the final byte of data from the MAX30208 followed by a STOP condition.

I²C Write Data Format

A write to the MAX30208 includes transmission of a START condition, the slave address with the R/W bit set to 0, one byte of data to configure the internal register address pointer, one or more bytes of data, and a STOP condition. [Figure 6](#) illustrates the proper frame format for writing one byte of data to the MAX30208. [Figure 7](#) illustrates the frame format for writing n-bytes of data to the MAX30208.

The master first sends the slave address with the R/W bit set to 0. This indicates that the master intends to write data to the MAX30208. The MAX30208 acknowledges receipt of the address byte during the master-generated 9th SCL pulse.

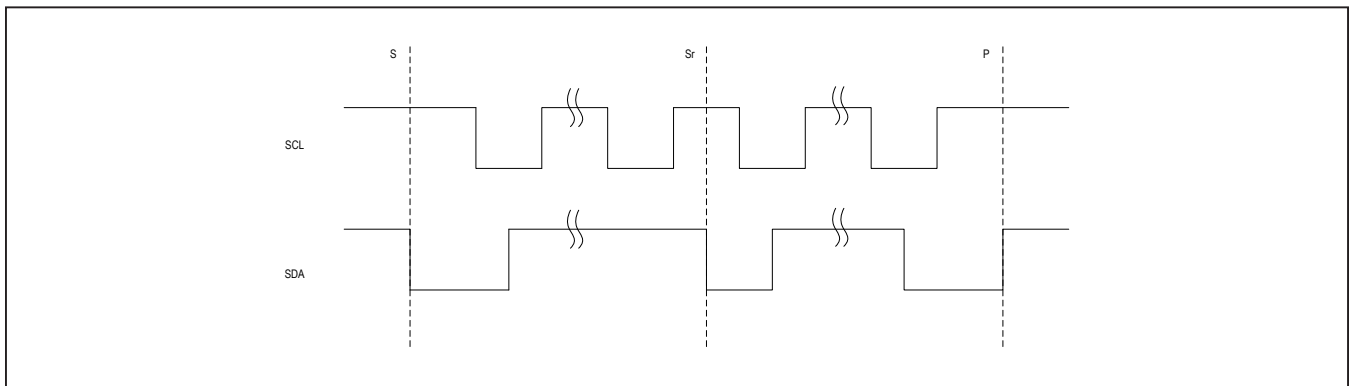

Figure 4.: I²C Start (S) , Stop (P), and Repeated Start (Sr) Conditions

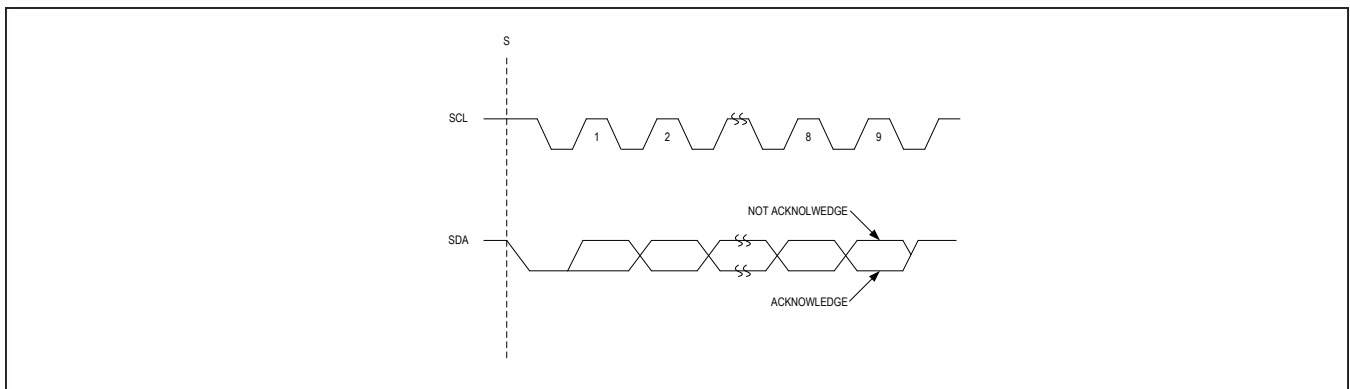

Figure 5. I²C Acknowledge Bit

The second byte transmitted from the master configures the MAX30208's internal register address pointer. The pointer tells the MAX30208 where to write the next byte of data. An acknowledge pulse is sent by the MAX30208 upon receipt of the address pointer data.

The third byte sent to the MAX30208 contains the data that is written to the chosen register. An acknowledge pulse from the MAX30208 signals receipt of the data byte. The address pointer auto increments to the next register address after each received data byte. This auto-increment feature allows a master to write to sequential registers within one continuous frame. The master signals the end of transmission by issuing a STOP condition. The auto-increment feature is disabled when there is an attempt to write to the FIFO_DATA (0x08) register.

The master signals the end of transmission by issuing a STOP condition. The auto-increment feature is disabled when there is an attempt to write to the FIFO_DATA (0x08) register.

I²C Read Data Format

The master sends the slave address with the R/W bit set to 1 to initiate a read operation. The MAX30208 acknowledges receipt of its slave address by pulling SDA low during the 9th SCL clock pulse. A START command followed by a read command resets the address pointer to register 0x00.

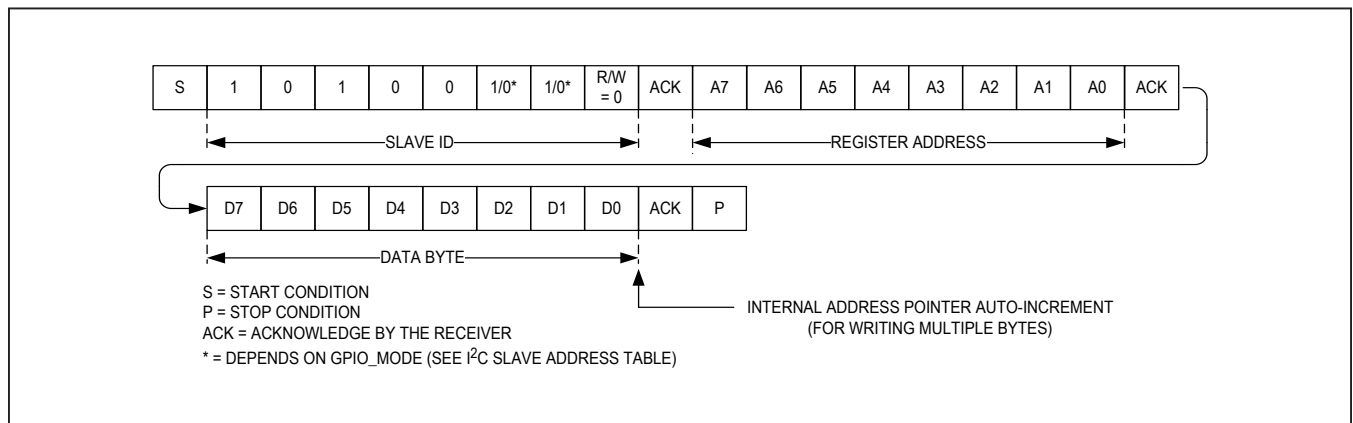

Figure 6. I²C Single Byte Write Transaction

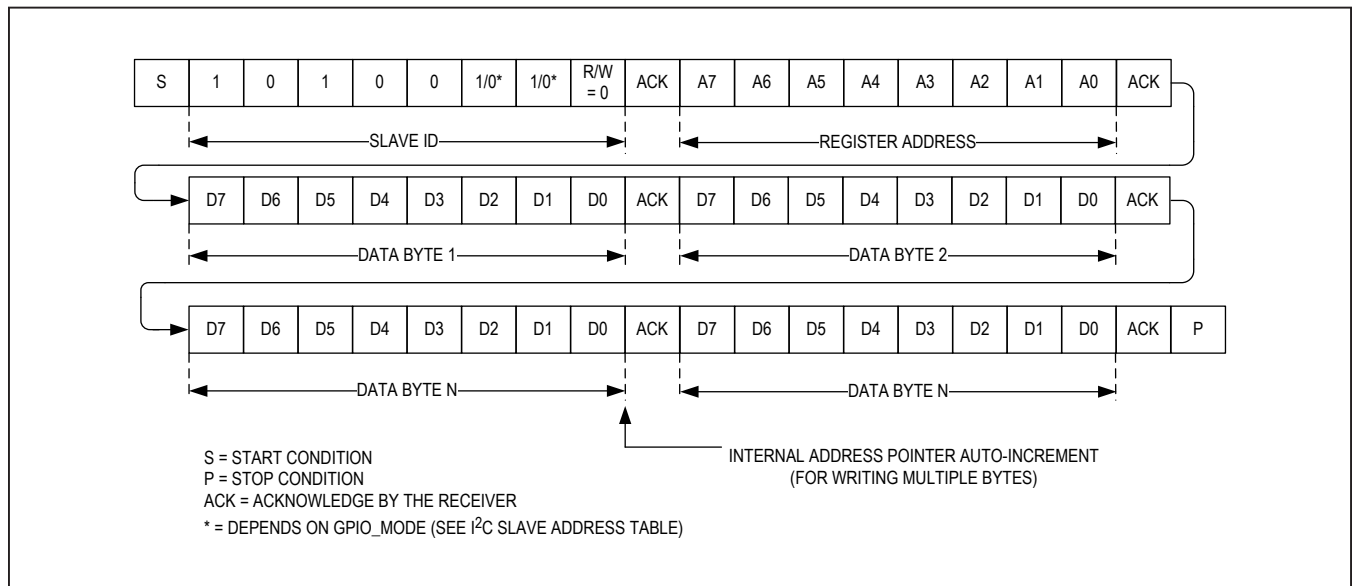

Figure 7. I²C Multi-Byte Write Transaction

The first byte transmitted from the MAX30208 contains the data in register 0x00. Transmitted data is valid on the rising edge of SCL. The address pointer auto-increments after each read data byte. This auto-increment feature allows all registers to be read sequentially within one continuous frame. The auto_increment feature is disabled when there is an attempt to read from the FIFO_DATA register, this allows for burst reading of the FIFO_DATA register. A STOP condition can be issued after any number of read data bytes. If a STOP condition is issued followed by another read operation, the first data byte to be read is from register 0x00.

The address pointer can be preset to a specific register before a read command is issued. The master presets the address pointer by first sending the MAX30208 slave

address with the R/W bit set to 0 followed by the register address. A REPEATED START condition is then sent followed by the slave address with the R/W bit set to 1. The MAX30208 then transmits the contents of the specified register. The address pointer auto-increments after transmitting the first byte.

The master acknowledges receipt of each read byte during the acknowledge clock pulse. The master must acknowledge all correctly received bytes except the last byte. The final byte must be followed by a not acknowledge from the master and then a STOP condition. Figure 8 illustrates the frame format for reading one byte from the MAX30208. Figure 9 illustrates the frame format for reading multiple bytes from the MAX30208.

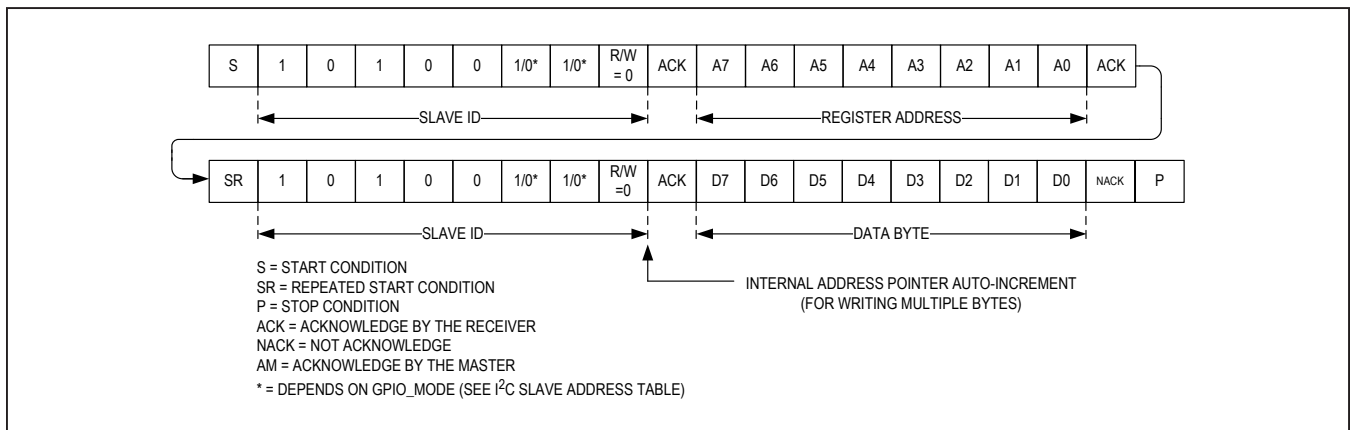

Figure 8. I²C Single Byte Read Transaction

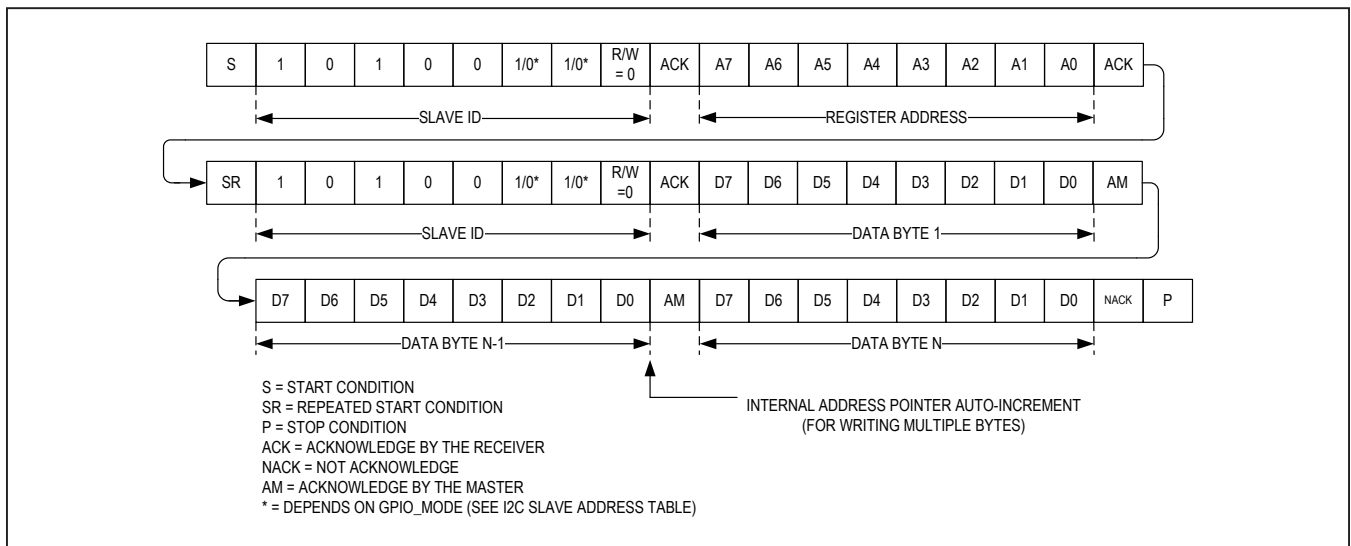

Figure 9. I²C Multi-Byte Read Transaction

FIFO Description

The FIFO is 32 samples long and is designed for 16-bit temperature data. The master does a burst read of two bytes starting at register 0x08 to read one 16-bit temperature sample, referred to as a word, from the FIFO. The master reads 2N bytes from the FIFO to get N samples.

There are seven registers that control how the FIFO is configured and read out. These registers are illustrated below.

FIFO_WR_PTR (address 0x04), Write Pointer

FIFO_WR_PTR[4:0] points to the FIFO location where the next word is written. This pointer advances for each word pushed on to the FIFO by the internal conversion process. The write pointer is updated from a 5-bit counter and wraps around to count 0x00 from count 0x1F.

FIFO_RD_PTR (address 0x05), Read Pointer

FIFO_RD_PTR[4:0] points to the location where the next word of the FIFO is read using the I²C interface. This advances each time a word is read from the FIFO. The read pointer can be both read and written to. This allows a word to be reread from the FIFO if it has not already been overwritten. The read pointer is updated from a 5 bit counter and wraps around to count 0x00 from count 0x1F.

OVF_COUNTER (address 0x06), Overflow Counter

OVF_COUNTER[4:0] logs the number of words lost if new words are written after the FIFO is full. This counter saturates at count value 0x1F. Each time a complete word is popped from the FIFO, the OVF_COUNTER is reset to zero. The counter is useful as a debug tool. It should be read immediately before reading the FIFO in order to check if an overflow condition has occurred

FIFO_DATA_COUNT (address 0x07), FIFO Data Counter

FIFO_DATA_COUNT[5:0] is a read-only register, which holds the number of words available in the FIFO for the master to read. This increments when a new word is pushed to the FIFO, and decrements when the master reads a word from the FIFO

FIFO_DATA (address 0x08), FIFO Data

FIFO_DATA[7:0] is a read-only register used to retrieve data from the FIFO. It is important to burst read the word from the FIFO. Each word is two bytes. Burst reading two bytes from the FIFO_DATA register advances the FIFO_RD_PTR by one. This configuration is best illustrated by the examples below.

[Table 5](#) shows the temperature data format in the FIFO.

Table 4. FIFO Register Map

ADDRESS	REGISTER NAME	B7	B6	B5	B4	B3	B2	B1	B0
0x04	FIFO Write Pointer	-	-	-	FIFO_WR_PTR[4:0]				
0x05	FIFO Read Pointer	-	-	-	FIFO_RD_PTR[4:0]				
0x06	FIFO Overflow Counter	-	-	-	OVF_COUNTER[4:0]				
0x07	FIFO Data Counter	-	-	FIFO_DATA_COUNT[5:0]					
0x08	FIFO Data	FIFO_DATA[7:0]							
0x09	FIFO Configuration 1	-	-	-	FIFO_A_FULL[4:0]				
0x0A	FIFO Configuration 2	-	-	-	FLUSH_FIFO	FIFO_STAT_CLR	A_FULL_TYPE	FIFO_RO	-

Table 5. Temperature FIFO Data Format

FIFO DATA FORMAT (FIFO_DATA[15:0])															
Bit15	Bit14	Bit13	Bit12	Bit11	Bit10	Bit9	Bit8	Bit7	Bit6	Bit5	Bit4	Bit3	Bit2	Bit1	Bit0
T15	T14	T13	T12	T11	T10	T9	T8	T7	T6	T5	T4	T3	T2	T1	T0

Table 6 shows the order in which the two bytes of the temperature data are read using the serial interface.

Table 6. FIFO Data Read Format

SAMPLE NUMBER	BYTE NUMBER	FIFO DATA READ FORMAT							
		Bit7	Bit6	Bit5	Bit4	Bit3	Bit2	Bit1	Bit0
Sample N	1	T15	T14	T13	T12	T11	T10	T9	T8
	2	T7	T6	T5	T4	T3	T2	T1	T0
Sample N+1	1	T15	T14	T13	T12	T11	T10	T9	T8
	2	T7	T6	T5	T4	T3	T2	T1	T0
Sample N+2	1	T15	T14	T13	T12	T11	T10	T9	T8
	2	T7	T6	T5	T4	T3	T2	T1	T0
...									
Sample N+31	1	T15	T14	T13	T12	T11	T10	T9	T8
	2	T7	T6	T5	T4	T3	T2	T1	T0

FIFO_DATA Read Example

Number of samples available in the FIFO after the last read can be obtained by reading the OVF_COUNTER[4:0] and FIFO_DATA_COUNT[5:0] registers using the following pseudo-code:

```

read the OVF_COUNTER register
read the FIFO_DATA_COUNT register
if OVF_COUNTER == 0 //no overflow occurred
    NUM_AVAILABLE_SAMPLES = FIFO_DATA_COUNT
else,
    NUM_AVAILABLE_SAMPLES = 32 // overflow occurred and data has been lost
    
```

FIFO_WR_PTR[4:0] and FIFO_RD_PTR[4:0] are available for debug. They can also be used to calculate the number of available samples using the following pseudo-code:

```

If OVF_COUNTER is zero,
    NUM_AVAILABLE_WORDS = FIFO_WR_PTR – FIFO_RD_PTR
    (Note: pointer wrap around should be taken into account)
else,
    NUM_AVAILABLE_WORDS = 32
    
```

FIFO_A_FULL (address 0x09), FIFO Almost Full

The FIFO_A_FULL[4:0] field in the FIFO Configuration 1 [0x09] register sets the watermark for the FIFO and determines when the A_FULL bit in the STATUS [0x00] register is asserted. The A_FULL bit is set when the FIFO contains 32 minus FIFO_A_FULL[4:0] words. For example, when FIFO_A_FULL is set to 2, the flag is set when the 30th word is written to the FIFO. When the FIFO almost full condition is met, the A_FULL bit is asserted in the STATUS register. If the A_FULL_EN bit in the INTERRUPT_ENABLE [0x01] register is set and GPIO0_MODE = 0x3 in the GPIO_SETUP [0x20] register, then the interrupt is asserted on the GPIO0 pin. This condition should prompt the applications processor to read samples from the FIFO before it fills.

The bus master can read both the FIFO_WR_PTR and FIFO_RD_PTR to calculate the number of words available in the FIFO, or read the OVF_COUNTER and FIFO_DATA_COUNT registers, and read as many words as needed to empty the FIFO.

FIFO_RO (address 0x0A), FIFO Rollover

The FIFO_RO bit in the FIFO Configuration 2 [0x0A] register determines whether a sample is pushed onto the FIFO or discarded when it is full. If FIFO_RO is enabled when FIFO is full, old samples are overwritten. If FIFO_RO is not set, the new sample is discarded and the FIFO is not updated.

A_FULL_TYPE (address 0x0A), Almost Full Type

The A_FULL_TYPE bit defines the behavior of the A_FULL status bit. If the A_FIFO_TYPE bit is set low, the A_FULL status bit is asserted when the A_FULL condition is detected and cleared by a STATUS register read, then reasserts for every sample if the A_FULL condition persists. If the A_FIFO_TYPE bit is set high, the A_FULL status bit is asserted only when a new A_FULL condition is detected. The status bit is cleared by a STATUS register read and does not reassert for every sample until a new A_FULL condition is detected.

FIFO_STAT_CLR (address 0x0A), FIFO Status Clear

The FIFO_STAT_CLR bit defines whether the A_FULL and TEMP_RDY status bits should clear by a FIFO_DATA register read. If FIFO_STAT_CLR is set low, A_FULL and TEMP_RDY status bits are not cleared by a FIFO_DATA register read but are cleared by STATUS register read. If FIFO_STAT_CLR is set high, A_FULL and TEMP_RDY status bits are cleared by a FIFO_DATA register read or a STATUS register read.

FLUSH_FIFO (address 0x0A)

The FLUSH_FIFO bit is used for flushing the FIFO. The FIFO becomes empty and the FIFO_WR_PTR[4:0], FIFO_RD_PTR[4:0], FIFO_DATA_COUNT[5:0] and OVF_COUNTER[4:0] are reset to zero. FLUSH_FIFO is a self-clearing bit.

Register Map

ADDRESS	NAME	MSB							LSB
INTERRUPT AND STATUS									
0x00	STATUS[7:0]	A_FULL	-	-	-	-	TEMP_LO	TEMP_HI	TEMP_RDY
0x01	INTERRUPT ENABLE[7:0]	A_FULL_EN	-	-	-	-	TEMP_LO_EN	TEMP_HI_EN	TEMP_RDY_EN
FIFO									
0x04	FIFO WRITE POINTER[7:0]	-	-	-	FIFO_WR_PTR[4:0]				
0x05	FIFO READ POINTER[7:0]	-	-	-	FIFO_RD_PTR[4:0]				
0x06	FIFO OVERFLOW COUNTER[7:0]	-	-	-	OVF_COUNTER[4:0]				
0x07	FIFO DATA COUNTER[7:0]	-	-	FIFO_DATA_COUNT[5:0]					
0x08	FIFO DATA[7:0]	FIFO_DATA[7:0]							
0x09	FIFO CONFIGURATION 1[7:0]	-	-	-	FIFO_A_FULL[4:0]				
0x0A	FIFO CONFIGURATION 2[7:0]	-	-	-	FLUSH_FIFO	FIFO_STAT_CLR	A_FULL_TYPE	FIFO_RO	-
SYSTEM									
0x0C	SYSTEM CONTROL[7:0]	-	-	-	-	-	-	-	RESET
TEMPERATURE									
0x10	ALARM HIGH MSB[7:0]	ALARM_HI_MSB[7:0]							
0x11	ALARM HIGH LSB[7:0]	ALARM_HI_LSB[7:0]							
0x12	ALARM LOW MSB[7:0]	ALARM_LO_MSB[7:0]							
0x13	ALARM LOW LSB[7:0]	ALARM_LO_LSB[7:0]							
0x14	TEMP SENSOR SETUP[7:0]	RFU	-	-	-	-	-	-	CONVERT_T
GPIO									
0x20	GPIO SETUP[7:0]	GPIO1_MODE[1:0]		-	-	-	-	GPIO0_MODE[1:0]	
0x21	GPIO CONTROL[7:0]	-	-	-	-	GPIO1_LL	-	-	GPIO0_LL
IDENTIFIERS									
0x31	PART ID 1[7:0]	PART_ID1[7:0]							
0x32	PART ID 2[7:0]	PART_ID2[7:0]							
0x33	PART ID 3[7:0]	PART_ID3[7:0]							
0x34	PART ID 4[7:0]	PART_ID4[7:0]							
0x35	PART ID 5[7:0]	PART_ID5[7:0]							
0x36	PART ID 6[7:0]	PART_ID6[7:0]							
0xFF	PART IDENTIFIER[7:0]	PART_ID[7:0]							

Register Details

STATUS (0x0)

BIT	7	6	5	4	3	2	1	0
Field	A_FULL	–	–	–	–	TEMP_LO	TEMP_HI	TEMP_RDY
Reset	0b0	–	–	–	–	0x0	0x0	0b0
Access Type	Read Only	–	–	–	–	Read Only	Read Only	Read Only

BITFIELD	BITS	DESCRIPTION
A_FULL	7	This is a read-only bit. This bit is cleared when the Interrupt Status 1 Register is read. It is also cleared when FIFO_DATA register is read, if FIFO_STAT_CLR = 1
TEMP_LO	2	This bit is asserted when the latest temperature sensor measurement is less than what is programmed in the Temperature Sensor Alarm Low register. When this bit is asserted and if the TEMP_LO_EN bit is set to 1 then it asserts the interrupt on the GPIO0 pin when programmed as an interrupt output. The master needs to read the status register to determine if the interrupt was asserted by the TEMP_LO status. This bit is cleared after the STATUS register is read.
TEMP_HI	1	This bit is asserted when the latest temperature sensor measurement is greater than what is programmed in the Temperature Sensor Alarm High register. When this bit is asserted and if the TEMP_HI_EN bit is set to 1 then it asserts the interrupt on the GPIO0 pin when programmed as an interrupt output. The master needs to read the status register to determine if the interrupt was asserted by the TEMP_HI status. This bit is cleared after the STATUS register is read.
TEMP_RDY	0	This bit is asserted when a temperature sensor measurement has completed and new data is available to be read by the master. When this bit is asserted and if the TEMP_RDY_EN bit is set to 1, then it asserts the interrupt on the GPIO0 pin when programmed as an interrupt output. The master needs to read the status register to determine if the interrupt was asserted by the TEMP_RDY status. This bit is cleared after the STATUS register is read or after the Temperature Data registers are read.

INTERRUPT ENABLE (0x1)

BIT	7	6	5	4	3	2	1	0
Field	A_FULL_EN	–	–	–	–	TEMP_LO_EN	TEMP_HI_EN	TEMP_RDY_EN
Reset	0b0	–	–	–	–	0b0	0b0	0b0
Access Type	Write, Read	–	–	–	–	Write, Read	Write, Read	Write, Read

BITFIELD	BITS	DESCRIPTION
A_FULL_EN	7	Set A_FULL_EN to 1 to enable the A_FULL interrupt on GPIO0 when programmed as an interrupt output. Set A_FULL_EN to 0 to disable the A_FULL interrupt.
TEMP_LO_EN	2	Set TEMP_LO_EN to 1 to enable the TEMP_LO interrupt on the GPIO0 pin when programmed as an interrupt output. Set TEMP_LO_EN to 0 to disable the TEMP_LO interrupt.
TEMP_HI_EN	1	Set TEMP_HI_EN to 1 to enable the TEMP_HI interrupt on the GPIO0 pin when programmed as an interrupt output. Set TEMP_HI_EN to 0 to disable the TEMP_HI interrupt.
TEMP_RDY_EN	0	Set TEMP_RDY_EN to 1 to enable the TEMP_RDY interrupt on the GPIO0 pin when programmed as an interrupt output. Set TEMP_RDY_EN to 0 to disable the TEMP_RDY interrupt.

FIFO WRITE POINTER (0x04)

BIT	7	6	5	4	3	2	1	0
Field	–	–	–	FIFO_WR_PTR[4:0]				
Reset	–	–	–	0x00				
Access Type	–	–	–	Read Only				

BITFIELD	BITS	DESCRIPTION
FIFO_WR_PTR	4:0	See the FIFO Description section for details.

FIFO READ POINTER (0x05)

BIT	7	6	5	4	3	2	1	0
Field	–	–	–	FIFO_RD_PTR[4:0]				
Reset	–	–	–	0x00				
Access Type	–	–	–	Write, Read, Ext				

BITFIELD	BITS	DESCRIPTION
FIFO_RD_PTR	4:0	See the FIFO Description section for details.

FIFO OVERFLOW COUNTER (0x06)

BIT	7	6	5	4	3	2	1	0
Field	–	–	–	OVF_COUNTER[4:0]				
Reset	–	–	–	0x00				
Access Type	–	–	–	Read Only				

BITFIELD	BITS	DESCRIPTION
OVF_COUNTER	4:0	See the FIFO Description section for details.

FIFO DATA COUNTER (0x07)

BIT	7	6	5	4	3	2	1	0
Field	–	–	FIFO_DATA_COUNT[5:0]					
Reset	–	–	0x00					
Access Type	–	–	Read Only					

BITFIELD	BITS	DESCRIPTION
FIFO_DATA_COUNT	5:0	See the FIFO Description section for details.

FIFO DATA (0x08)

BIT	7	6	5	4	3	2	1	0
Field	FIFO_DATA[7:0]							
Reset	0x00							
Access Type	Read Only							

BITFIELD	BITS	DESCRIPTION
FIFO_DATA	7:0	See the FIFO Description section for details.

FIFO CONFIGURATION 1 (0x09)

BIT	7	6	5	4	3	2	1	0
Field	–	–	–	FIFO_A_FULL[4:0]				
Reset	–	–	–	0x0F				
Access Type	–	–	–	Write, Read				

BITFIELD	BITS	DESCRIPTION
FIFO_A_FULL	4:0	See the FIFO Description section for details.

FIFO CONFIGURATION 2 (0x0A)

BIT	7	6	5	4	3	2	1	0
Field	–	–	–	FLUSH_FIF0	FIF0_STAT_CLR	A_FULL_TYPE	FIF0_RO	–
Reset	–	–	–	0b0	0b0	0b0	0b0	–
Access Type	–	–	–	Write, Read	Write, Read	Write, Read	Write, Read	–

BITFIELD	BITS	DESCRIPTION
FLUSH_FIF0	4	See the FIFO Description section for details.
FIF0_STAT_CLR	3	See the FIFO Description section for details.
A_FULL_TYPE	2	See the FIFO Description section for details.
FIF0_RO	1	See the FIFO Description section for details.

SYSTEM CONTROL (0x0C)

BIT	7	6	5	4	3	2	1	0
Field	–	–	–	–	–	–	–	RESET
Reset	–	–	–	–	–	–	–	0b0
Access Type	–	–	–	–	–	–	–	Write Only

BITFIELD	BITS	DESCRIPTION
RESET	0	Setting this bit to 1 resets all register settings to default values. This is a self-clearing bit.

ALARM HIGH MSB (0x10)

BIT	7	6	5	4	3	2	1	0
Field	ALARM_HI_MSB[7:0]							
Reset	0x7F							
Access Type	Write, Read							

BITFIELD	BITS	DESCRIPTION
ALARM_HI_MSB	7:0	The ALARM_HI_MSB[7:0] bits are the most significant byte of the 16-bit temperature sensor alarm high bits. The ALARM_HI_MSB[7:0] and the ALARM_HI_LSB[7:0] bits form the full 16-bit temperature sensor Alarm High threshold. The default for the Alarm High threshold is 0x7FFF, which is the highest temperature setting and also disables the alarm.

ALARM HIGH LSB (0x11)

BIT	7	6	5	4	3	2	1	0
Field	ALARM_HI_LSB[7:0]							
Reset	0xFF							
Access Type	Write, Read							

BITFIELD	BITS	DESCRIPTION
ALARM_HI_LSB	7:0	The ALARM_HI_LSB[7:0] bits are the least significant byte of the 16-bit temperature sensor alarm high bits. The ALARM_HI_MSB[7:0] and the ALARM_HI_LSB[7:0] bits form the full 16-bit temperature sensor Alarm High threshold. The default for the Alarm High threshold is 0x7FFF, which is the highest temperature setting and also disables the alarm.

ALARM LOW MSB (0x12)

BIT	7	6	5	4	3	2	1	0
Field	ALARM_LO_MSB[7:0]							
Reset	0x80							
Access Type	Write, Read							

BITFIELD	BITS	DESCRIPTION
ALARM_LO_MSB	7:0	The ALARM_LO_MSB[7:0] bits are the most significant byte of the 16-bit temperature sensor alarm low bits. The ALARM_LO_MSB[7:0] and the ALARM_LO_LSB[7:0] bits form the full 16-bit temperature sensor Alarm Low threshold. The default for the Alarm Low threshold is 0x8000, which is the lowest temperature setting and also disables the alarm.

ALARM LOW LSB (0x13)

BIT	7	6	5	4	3	2	1	0
Field	ALARM_LO_LSB[7:0]							
Reset	0x00							
Access Type	Write, Read							

BITFIELD	BITS	DESCRIPTION
ALARM_LO_LSB	7:0	The ALARM_LO_LSB[7:0] bits are the least significant byte of the 16-bit temperature sensor alarm high bits. The ALARM_LO_MSB[7:0] and the ALARM_LO_LSB[7:0] bits form the full 16-bit temperature sensor Alarm Low threshold. The default for the Alarm Low threshold is 0x8000, which is the lowest temperature setting and also disables the alarm.

TEMP SENSOR SETUP (0x14)

BIT	7	6	5	4	3	2	1	0
Field	RFU		–	–	–	–	–	CONVERT_T
Reset	0b11		–	–	–	–	–	0b0
Access Type	–		–	–	–	–	–	Write, Read

BITFIELD	BITS	DESCRIPTION
RFU	7:6	These bits are reserved for future use. When writing to this register, these bits must always be set to 1.
CONVERT_T	0	Writing '1' to this field starts temperature measurement. This is a self clearing bit, and automatically resets to 0 when the temperature measurement completes.

GPIO SETUP (0x20)

BIT	7	6	5	4	3	2	1	0
Field	GPIO1_MODE[1:0]		–	–	–	–	GPIO0_MODE[1:0]	
Reset	0b10		–	–	–	–	0b10	
Access Type	Write, Read		–	–	–	–	Write, Read	

BITFIELD	BITS	DESCRIPTION
GPIO1_MODE	7:6	00 = Digital input (HiZ). GPIO1 logic level read from the GPIO1_LL bit in the GPIO_CONTROL register 01 = Digital output (open-drain). Set GPIO1 logic level by writing to the GPIO1_LL bit in the GPIO_CONTROL register. 10 = Digital input with 1MΩ pulldown 11 = Convert Temperature Input (active low)
GPIO0_MODE	1:0	00 = Digital input (HiZ). GPIO0 logic level read from the GPIO0_LL bit in the GPIO_CONTROL register 01 = Digital output (open-drain). Set GPIO0 logic level by writing to the GPIO0_LL bit in the GPIO_CONTROL register 10 = Digital input with 1MΩ pulldown 11 = INTB (open-drain, active low)

GPIO CONTROL (0x21)

BIT	7	6	5	4	3	2	1	0
Field	–	–	–	–	GPIO1_LL	–	–	GPIO0_LL
Reset	–	–	–	–	0b0	–	–	0b0
Access Type	–	–	–	–	Write, Read	–	–	Write, Read

BITFIELD	BITS	DESCRIPTION
GPIO1_LL	3	If GPIO1 is programmed as a digital output, then set the GPIO1_LL bit to 0 to make the GPIO1 pin a logic low level or set the corresponding GPIO1_LL bit to 1 to make the GPIO1 pin a logic high level. A read of the GPIO1_LL bit returns the logic level on the corresponding GPIO1 pin when the register is read, regardless of the GPIO1 mode.
GPIO0_LL	0	If GPIO0 is programmed as a digital output, then set the GPIO0_LL bit to 0 to make the GPIO0 pin a logic low level or set the corresponding GPIO0_LL bit to 1 to make the GPIO0 pin a logic high level. A read of the GPIO0_LL bit returns the logic level on the corresponding GPIO0 pin when the register is read, regardless of the GPIO0 mode.

PART ID 1 (0x31)

BIT	7	6	5	4	3	2	1	0
Field	PART_ID1[7:0]							
Reset								
Access Type	Read Only							

BITFIELD	BITS	DESCRIPTION
PART_ID1	7:0	Factory set to unique ID

PART ID 2 (0x32)

BIT	7	6	5	4	3	2	1	0
Field	PART_ID2[7:0]							
Reset								
Access Type	Read Only							

BITFIELD	BITS	DESCRIPTION
PART_ID2	7:0	Factory set to unique ID.

PART ID 3 (0x33)

BIT	7	6	5	4	3	2	1	0
Field	PART_ID3[7:0]							
Reset								
Access Type	Read Only							

BITFIELD	BITS	DESCRIPTION
PART_ID3	7:0	Factory set to unique ID.

PART ID 4 (0x34)

BIT	7	6	5	4	3	2	1	0
Field	PART_ID4[7:0]							
Reset								
Access Type	Read Only							

BITFIELD	BITS	DESCRIPTION
PART_ID4	7:0	Factory set to unique ID.

PART ID 5 (0x35)

BIT	7	6	5	4	3	2	1	0
Field	PART_ID5[7:0]							
Reset								
Access Type	Read Only							

BITFIELD	BITS	DESCRIPTION
PART_ID5	7:0	Factory set to unique ID.

PART ID 6 (0x36)

BIT	7	6	5	4	3	2	1	0
Field	PART_ID6[7:0]							
Reset								
Access Type	Read Only							

BITFIELD	BITS	DESCRIPTION
PART_ID6	7:0	Factory set to unique ID.

PART IDENTIFIER (0xFF)

BIT	7	6	5	4	3	2	1	0
Field	PART_ID[7:0]							
Reset	0x30							
Access Type	Read Only							

BITFIELD	BITS	DESCRIPTION
PART_ID	7:0	

Typical Application Circuits

MAX30208 Single-Point Temperature Sensing

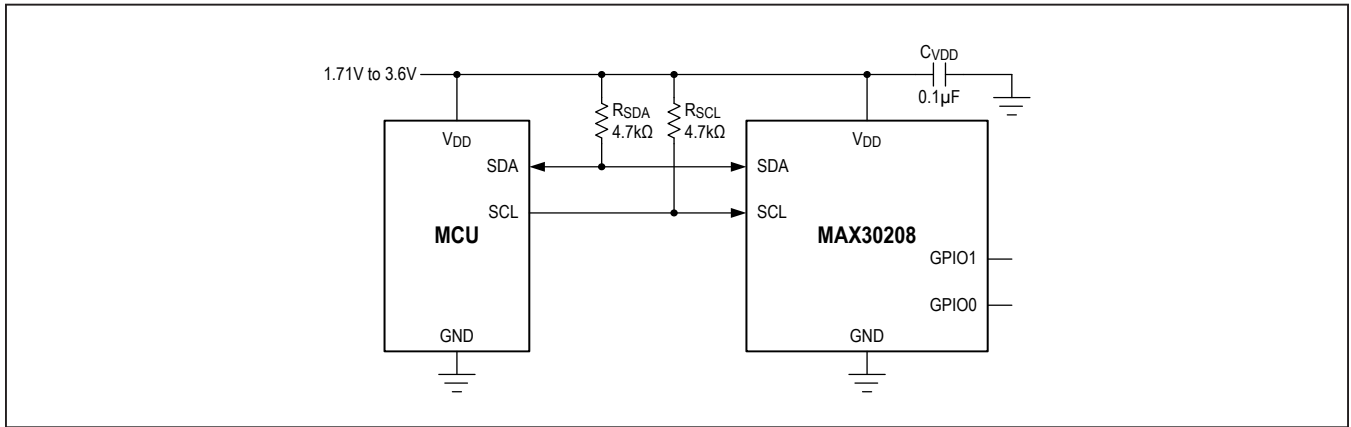

MAX30208 Single-Point Temperature Sensing with Special Features

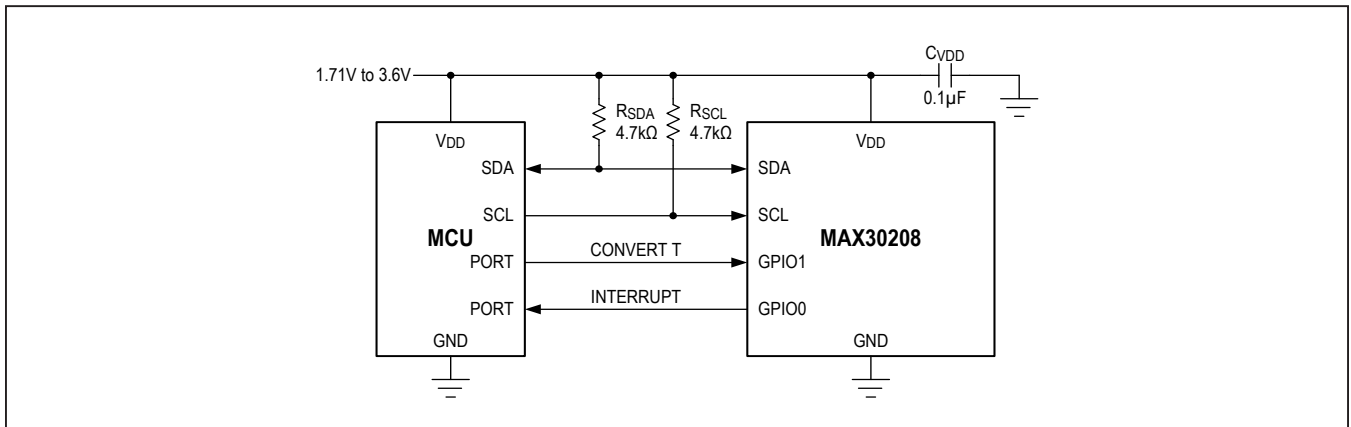

MAX30208 Multi-Point Temperature Sensing with up to 4 I²C Addresses

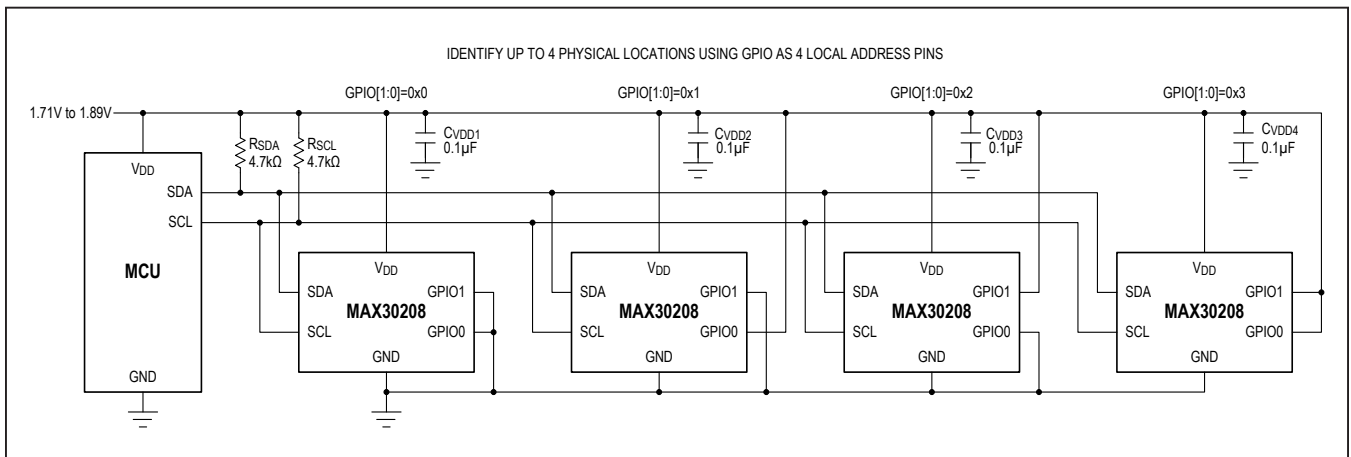

Ordering Information

PART NUMBER	TEMP RANGE	PIN-PACKAGE
MAX30208CLB+	0°C to +70°C	10 Pin Thin LGA
MAX30208CLB+T	0°C to +70°C	10 Pin Thin LGA

+ Denotes a lead(Pb)-free/RoHS-compliant package.

T Denotes tape-and-reel.

Revision History



REVISION NUMBER	REVISION DATE	DESCRIPTION	PAGES CHANGED
0	5/19	Initial release	—
1	5/20	Updated <i>Accuracy vs. Temperature</i> and <i>Electrical Characteristics</i> sections, and TOC05–TOC08	1–2, 5

For pricing, delivery, and ordering information, please visit Maxim Integrated's online storefront at <https://www.maximintegrated.com/en/storefront/storefront.html>.

Maxim Integrated cannot assume responsibility for use of any circuitry other than circuitry entirely embodied in a Maxim Integrated product. No circuit patent licenses are implied. Maxim Integrated reserves the right to change the circuitry and specifications without notice at any time. The parametric values (min and max limits) shown in the Electrical Characteristics table are guaranteed. Other parametric values quoted in this data sheet are provided for guidance.

Looking for pricing, stock, or lifecycle information?

Click below to explore more details on WIN SOURCE:

-  View [MAX30208CLB+T](#) on WIN SOURCE
-  [Maxim Integrated](#) Information

Optimize Your Supply Chain with WIN SOURCE Solutions

-  Global Sourcing Solution
-  Obsolete Management
-  Cost Control Management
-  Shortage Management
-  Alternative Solution
-  Excess Inventory Management