



THE DATASHEET OF DS75452MX



DS75450,DS75451,DS75452,DS75453,DS75454

DS75451/2/3 Series Dual Peripheral Drivers



Literature Number: SNOSBM3A

DS75451/2/3

Series Dual Peripheral Drivers

General Description

The DS7545X series of dual peripheral drivers is a family of versatile devices designed for use in systems that use TTL logic. Typical applications include high speed logic buffers, power drivers, relay drivers, lamp drivers, MOS drivers, bus drivers and memory drivers.

The DS75451, DS75452 and DS75453 are dual peripheral AND, NAND and NOR drivers, respectively, (positive logic) with the output of the logic gates internally connected to the bases of the NPN output transistors.

Features

- 300 mA output current capability
- High voltage outputs
- No output latch-up at 20V
- High speed switching
- Choice of logic function
- TTL compatible diode-clamped inputs
- Standard supply voltages
- Replaces TI "A" and "B" series

Connection Diagrams (Dual-In-Line and Metal Can Packages)

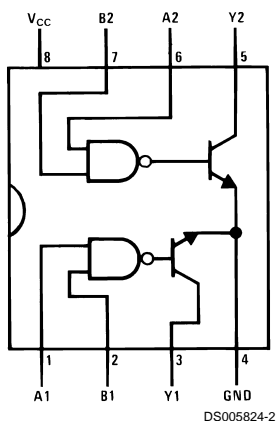

*See (Note 5) and Appendix E regarding S.O. package power dissipation constraints.

Top View
Order Number **DS75451M** or **DS75451N**

See NS Package Numbers M08A* or N08E

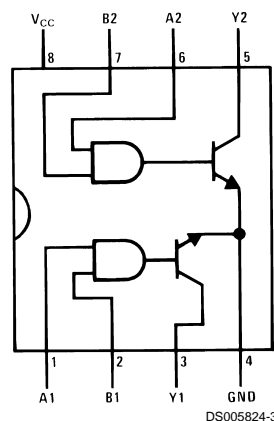

Top View
Order Number **DS75452M** or **DS75452N**

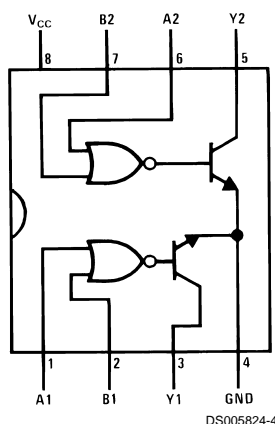

*See (Note 5) and Appendix E regarding S.O. package power dissipation constraints.

Top View
Order Number **DS75453M** or **DS75453N**
See NS Package Numbers M08A* or N08E

Absolute Maximum Ratings (Note 1)

If Military/Aerospace specified devices are required, please contact the National Semiconductor Sales Office/Distributors for availability and specifications.

Supply Voltage, (V_{CC}) (Note 2)	7.0V
Input Voltage	5.5V
Inter-Emitter Voltage (Note 3)	5.5V
Output Voltage (Note 4)	30V
Output Current (Note 5)	300 mA
Maximum Power (Note 5)	
Dissipation [†] at 25°C	

Molded DIP Package	957 mW
SO Package	632 mW
Storage Temperature Range	-65°C to +150°C
Lead Temperature (Soldering, 4 sec.)	260°C

Operating Conditions

	Min	Max	Units
Supply Voltage, (V_{CC})	4.75	5.25	V
Temperature, (T_A)	0	+70	°C

[†]Derate molded package 7.7 mW/°C above 25°C, derate SO package 7.56 mW/°C above 25°C.

Electrical Characteristics

(Notes 6, 7)

Symbol	Parameter	Conditions			Min	Typ	Max	Units
V_{IH}	High-Level Input Voltage	(Figure 7)			2			V
V_{IL}	Low-Level Input Voltage						0.8	V
V_I	Input Clamp Voltage	$V_{CC} = \text{Min}, I_I = -12 \text{ mA}$					-1.5	V
V_{OL}	Low-Level Output Voltage	$V_{CC} = \text{Min},$ (Figure 7)	$V_{IL} = 0.8 \text{ V}$	$I_{OL} = 100 \text{ mA}$ DS75451, DS75453		0.25	0.4	V
				$I_{OL} = 300 \text{ mA}$ DS75451, DS75453		0.5	0.7	V
			$V_{IH} = 2 \text{ V}$	$I_{OL} = 100 \text{ mA}$ DS75452		0.25	0.4	V
				$I_{OL} = 300 \text{ mA}$ DS75452		0.5	0.7	V
I_{OH}	High-Level Output Current	$V_{CC} = \text{Min},$ (Figure 7)	$V_{OH} = 30 \text{ V}$	$V_{IH} = 2 \text{ V}$ DS75451, DS75453			100	μA
				$V_{IL} = 0.8 \text{ V}$ DS75452			100	μA
I_I	Input Current at Maximum Input Voltage	$V_{CC} = \text{Max}, V_I = 5.5 \text{ V},$ (Figure 9)					1	mA
I_{IH}	High-Level Input Current	$V_{CC} = \text{Max}, V_I = 2.4 \text{ V},$ (Figure 9)					40	μA
I_{IL}	Low-Level Input Current	$V_{CC} = \text{Max}, V_I = 0.4 \text{ V},$ (Figure 8)				-1	-1.6	mA
I_{CCH}	Supply Current, Outputs High	$V_{CC} = \text{Max},$ (Figure 10)	$V_I = 5 \text{ V}$ DS75451		7	11	mA	
			$V_I = 0 \text{ V}$ DS75452		11	14	mA	
			$V_I = 5 \text{ V}$ DS75453		8	11	mA	
I_{CCL}	Supply Current, Outputs Low	$V_{CC} = \text{Max},$ (Figure 10)	$V_I = 0 \text{ V}$ DS75451		52	65	mA	
			$V_I = 5 \text{ V}$ DS75452		56	71	mA	
			$V_I = 0 \text{ V}$ DS75453		54	68	mA	

Switching Characteristics $(V_{CC} = 5 \text{ V}, T_A = 25^\circ\text{C})$

Symbol	Parameter	Conditions	Min	Typ	Max	Units
t_{PLH}	Propagation Delay Time, Low-to-High Level Output	$C_L = 15 \text{ pF}, R_L = 50\Omega,$ $I_O \approx 200 \text{ mA},$ (Figure 14)	DS75451	18	25	ns
			DS75452	26	35	ns
			DS75453	18	25	ns
t_{PHL}	Propagation Delay Time, High-to-Low Level Output	$C_L = 15 \text{ pF}, R_L = 50\Omega,$ $I_O \approx 200 \text{ mA},$ (Figure 14)	DS75451	18	25	ns
			DS75452	24	35	ns
			DS75453	16	25	ns
t_{TLH}	Transition Time, Low-to-High Level Output	$C_L = 15 \text{ pF}, R_L = 50\Omega, I_O \approx 200 \text{ mA},$ (Figure 14)		5	8	ns
t_{THL}	Transition Time, High-to-Low Level Output	$C_L = 15 \text{ pF}, R_L = 50\Omega, I_O \approx 200 \text{ mA},$ (Figure 14)		7	12	ns
V_{OH}	High-Level Output Voltage after Switching	$V_S = 20 \text{ V}, I_O \approx 300 \text{ mA},$ (Figure 15)	$V_S - 6.5$			mV

Switching Characteristics (Continued)

Note 1: "Absolute Maximum Ratings" are those values beyond which the safety of the device cannot be guaranteed. Except for "Operating Temperature Range" they are not meant to imply that the devices should be operated at these limits. The table of "Electrical Characteristics" provides conditions for actual device operation.

Note 2: Voltage values are with respect to network ground terminal unless otherwise specified.

Note 3: The voltage between two emitters of a multiple-emitter transistor.

Note 4: The maximum voltage which should be applied to any output when it is in the "OFF" state.

Note 5: Both halves of these dual circuits may conduct rated current simultaneously; however, power dissipation averaged over a short time interval must fall within the continuous dissipation rating.

Note 6: Unless otherwise specified min/max limits apply across 0°C to +70°C range. All typicals are given for $V_{CC} = +5V$ and $T_A = 25^\circ C$.

Note 7: All currents into device pins shown as positive, out of device pins as negative, all voltages referenced to ground unless otherwise noted. All values shown as max or min on absolute value basis.

Truth Tables (H = high level, L = low level)

DS75451

A	B	Y
L	L	L (ON State)
L	H	L (ON State)
H	L	L (ON State)
H	H	H (OFF State)

DS75452

A	B	Y
L	L	H (OFF State)
L	H	H (OFF State)
H	L	H (OFF State)
H	H	L (ON State)

DS75453

A	B	Y
L	L	L (ON State)
L	H	H (OFF State)
H	L	H (OFF State)
H	H	H (OFF State)

Schematic Diagrams

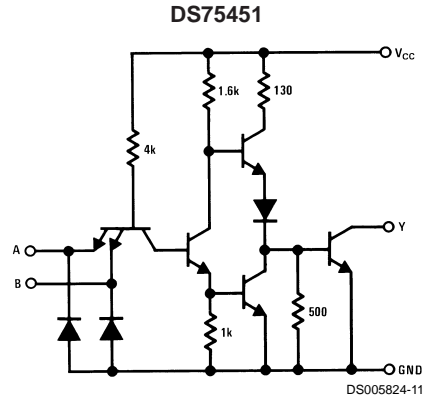

Resistor values shown are nominal.

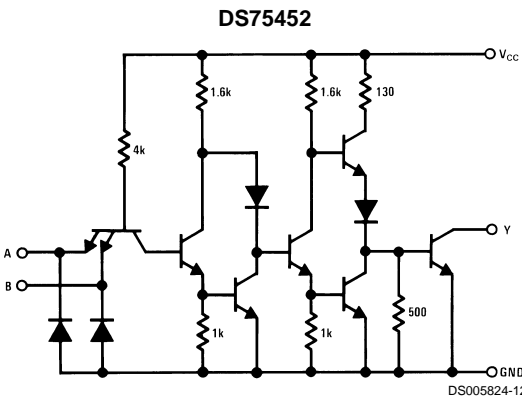

Resistor values shown are nominal.

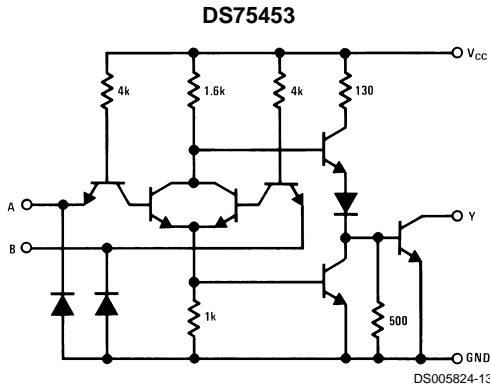

Resistor values shown are nominal.

DC Test Circuits

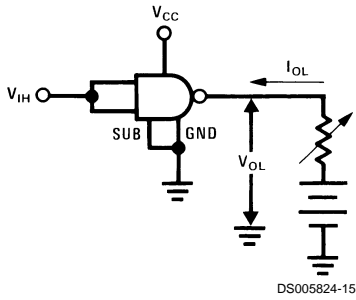

Both inputs is tested simultaneously.

FIGURE 1. V_{IH} , V_{OL}

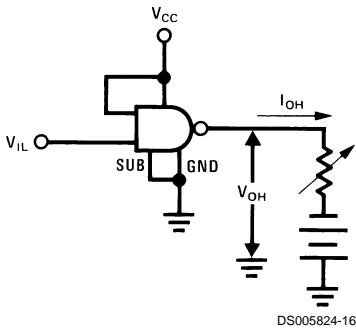

Each input is tested separately.

FIGURE 2. V_{IL} , V_{OH}

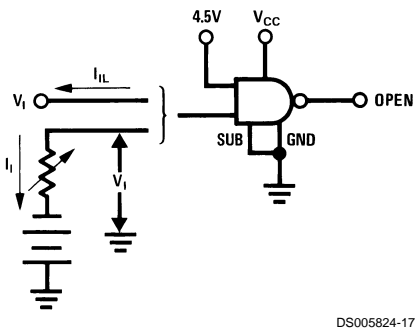

Each input is tested separately.

FIGURE 3. V_I , I_{IL}

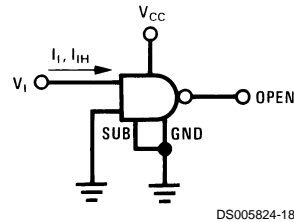

Each input is tested separately.

FIGURE 4. I_I , I_{IH}

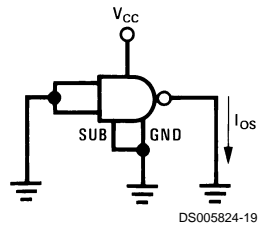

Each input is tested separately.

FIGURE 5. I_{OS}

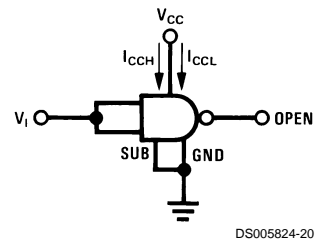

Both gates are tested simultaneously.

FIGURE 6. I_{CCH} , I_{CCL}

DC Test Circuits (Continued)

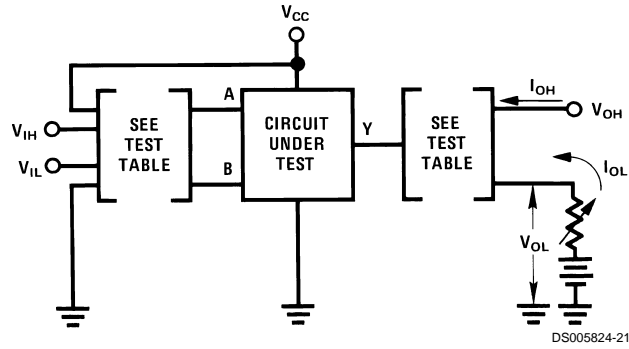

DS005824-21

Circuit	Input Under Test	Other Input	Output	
			Apply	Measure
DS75451	V_{IH}	V_{IH}	V_{OH}	I_{OL}
	V_{IL}	V_{CC}	I_{OL}	V_{OL}
DS75452	V_{IH}	V_{IH}	I_{OL}	V_{OL}
	V_{IL}	V_{CC}	V_{OH}	I_{OH}
DS75453	V_{IH}	Gnd	V_{OH}	I_{OH}
	V_{IL}	V_{IL}	I_{OL}	V_{OH}

FIGURE 7. V_{IH} , V_{IL} , I_{OH} , V_{OL}

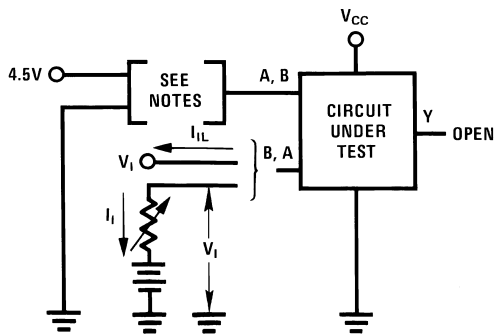

DS005824-22

Note A: Each input is tested separately.
Note B: When testing DS75453 input not under test is grounded. For all other circuits it is at 4.5V.

FIGURE 8. V_I , V_{IL}

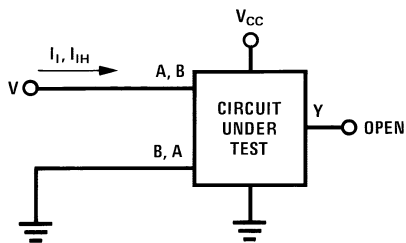

DS005824-23

Each input is tested separately.

FIGURE 9. I_I , I_{IH}

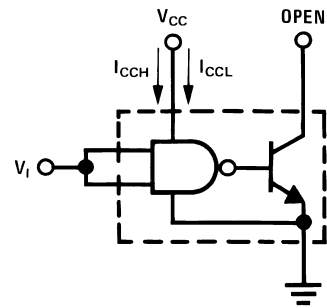

DS005824-24

Both gates are tested simultaneously.

FIGURE 10. I_{CCH} , I_{CCL} for AND, NAND Circuits

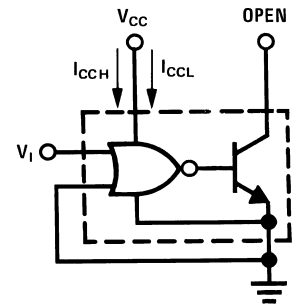

DS005824-25

Both gates are tested simultaneously.

FIGURE 11. I_{CCH} , I_{CCL} for OR, NOR Circuits

AC Test Circuits and Switching Time Waveforms

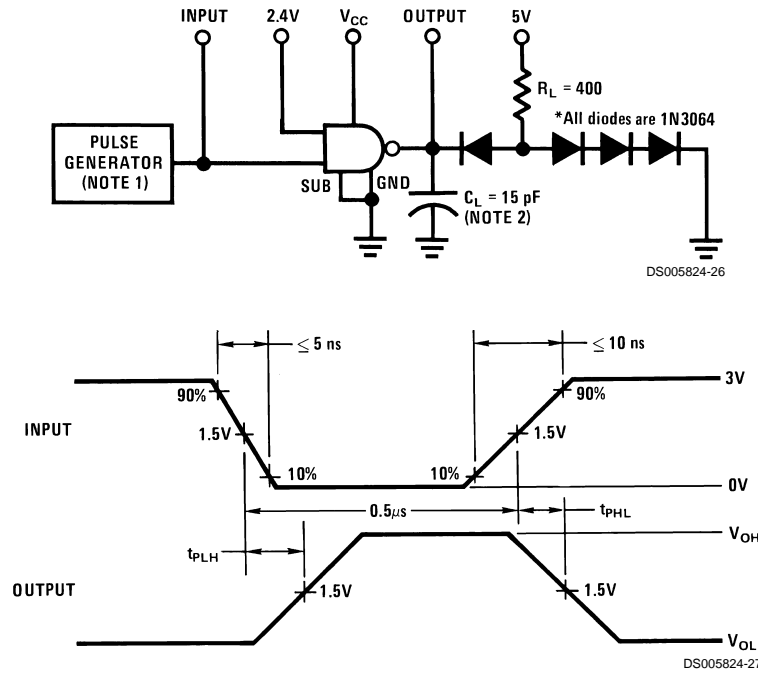

Note 1: The pulse generator has the following characteristics: PRR = 1 MHz, $Z_{OUT} \approx 50\Omega$.

Note 2: C_L includes probe and jig capacitance.

FIGURE 12. Propagation Delay Times, Each Gate

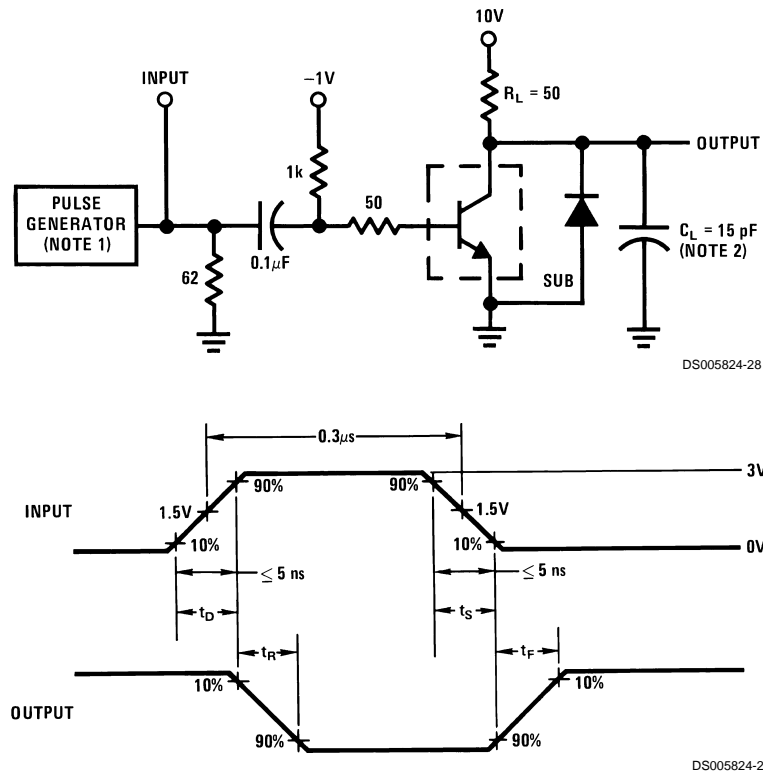

Note 1: The pulse generator has the following characteristics: duty cycle $\leq 1\%$, $Z_{OUT} \approx 50\Omega$.

Note 2: C_L includes probe and jig capacitance.

FIGURE 13. Switching Times, Each Transistor

AC Test Circuits and Switching Time Waveforms (Continued)

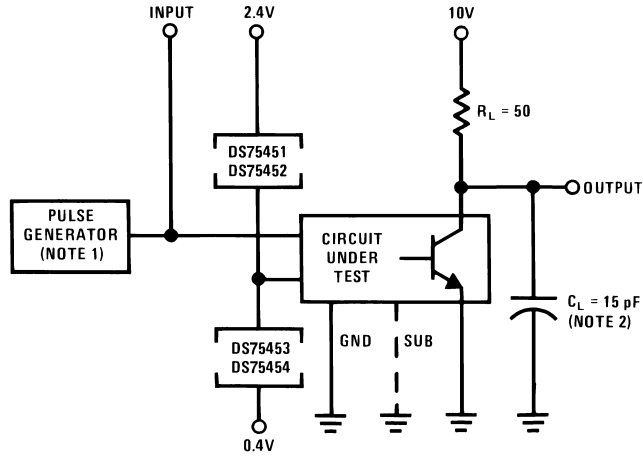

DS005824-30

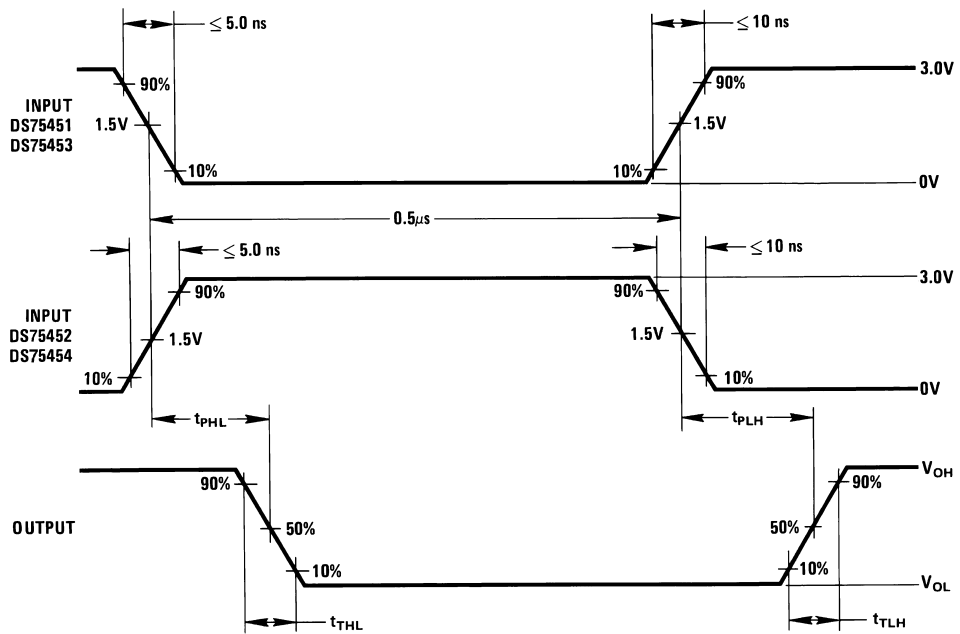

DS005824-31

Note 1: The The pulse generator has the following characteristics: PRR = 1.0 MHz, $Z_{OUT} \approx 50\Omega$.

Note 2: C_L includes probe and jig capacitance.

FIGURE 14. Switching Times of Complete Drivers

AC Test Circuits and Switching Time Waveforms (Continued)

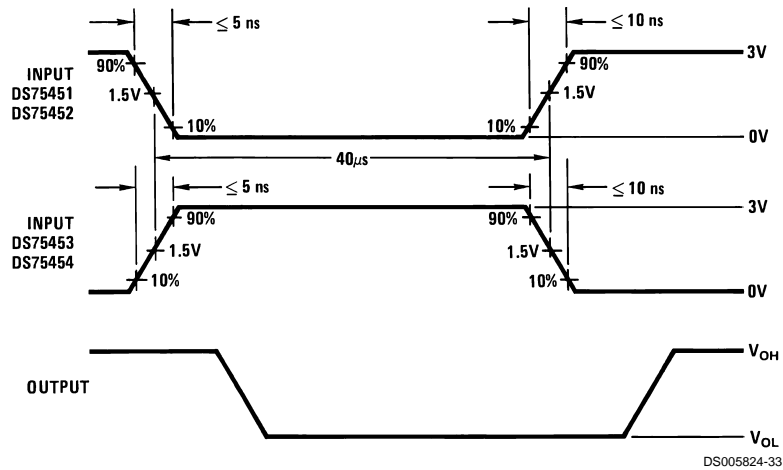
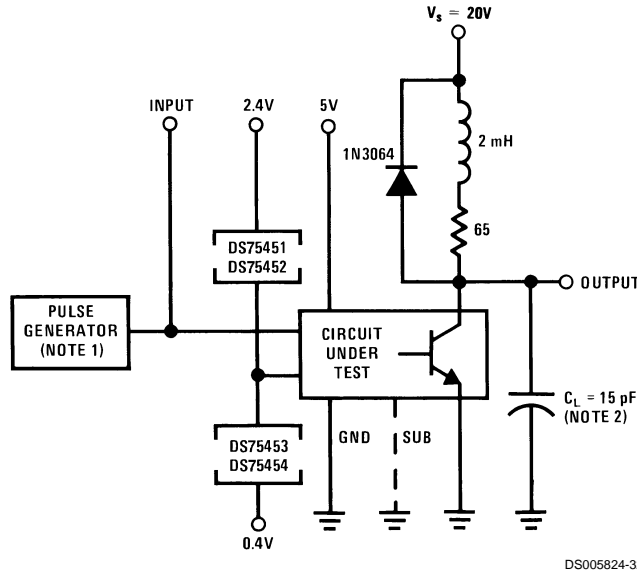

Note 1: The pulse generator has the following characteristics: PRR = 12.5 kHz, $Z_{OUT} \approx 50\Omega$.
Note 2: C_L includes probe and jig capacitance.

FIGURE 15. Latch-UP Test of Complete Drivers

Typical Performance Characteristics

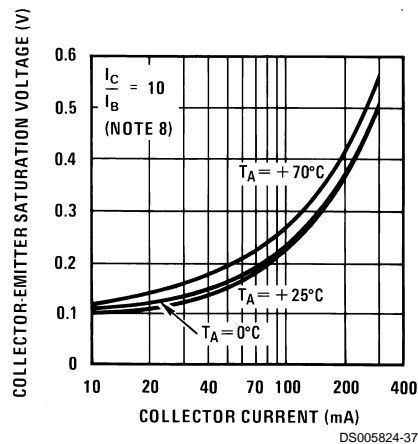
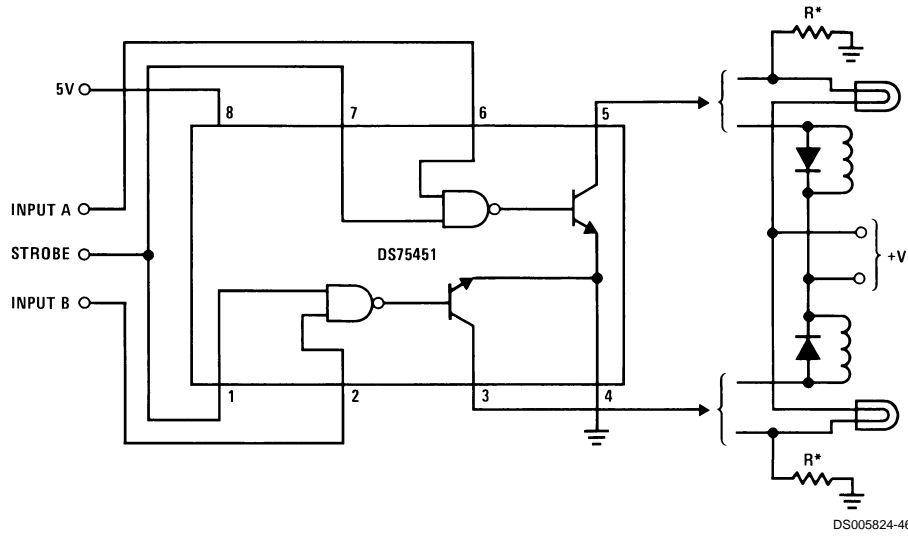

FIGURE 16. Transistor Collector-Emitter Saturation Voltage vs Collector Current

Typical Applications



*Optional keep-alive resistors maintain off-state lamp current at $\approx 10\%$ to reduce surge current.

FIGURE 17. Dual Lamp or Relay Driver

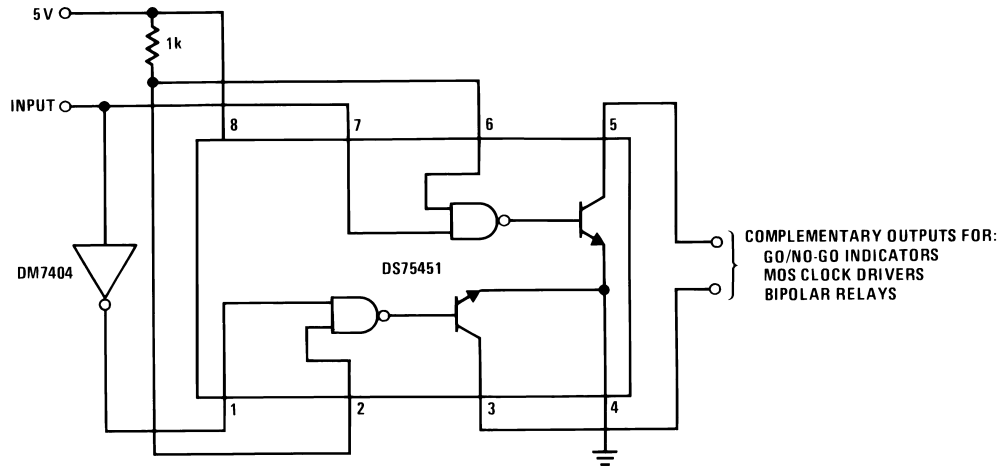

FIGURE 18. Complementary Driver

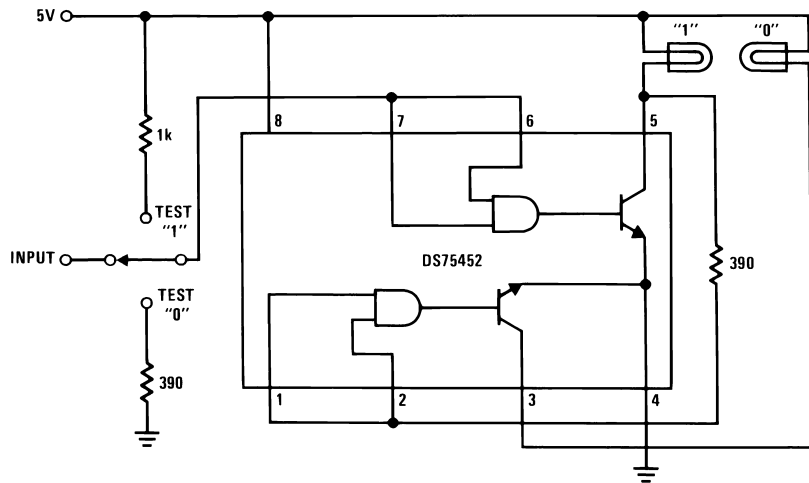
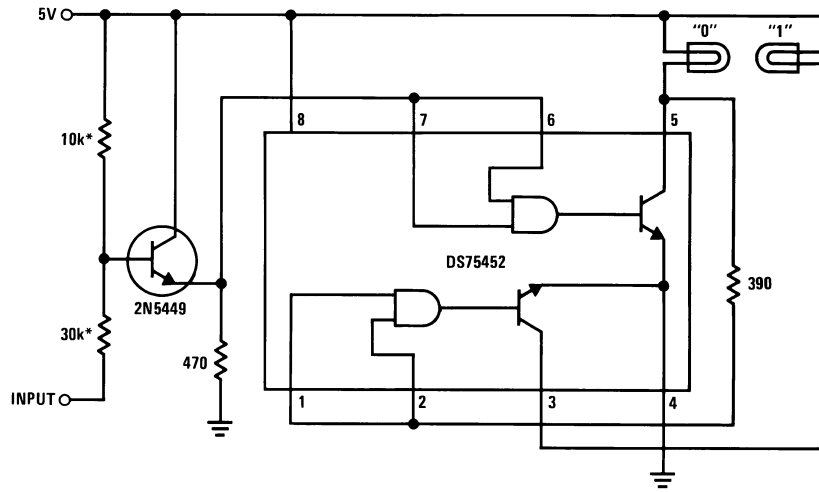

FIGURE 19. TTL or DTL Positive Logic-Level Detector

Typical Applications (Continued)



DS005824-49

*The two input resistors must be adjusted for the level of MOS input.

FIGURE 20. MOS Negative Logic-Level Detector

Typical Applications (Continued)

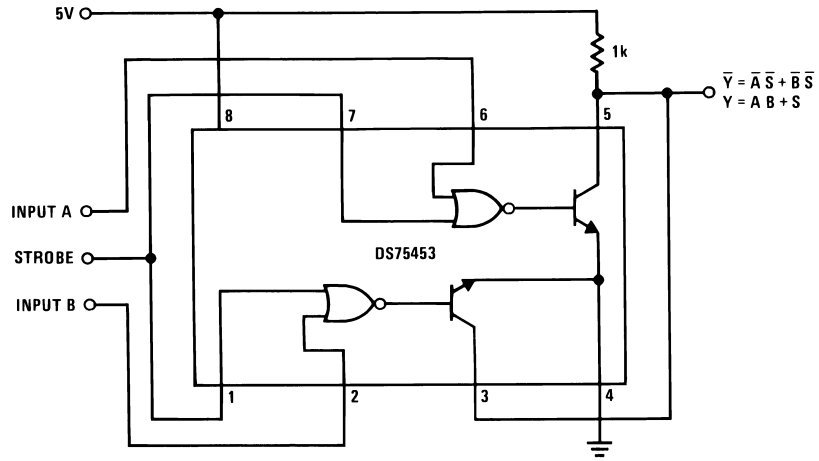

DS005824-50

FIGURE 21. Logic Signal Comparator

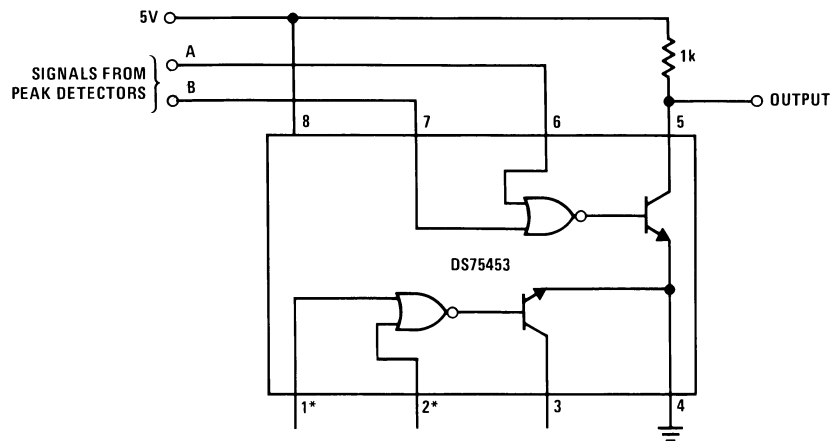

DS005824-51

*If inputs are unused, they should be connected to +5V through a 1k resistor.

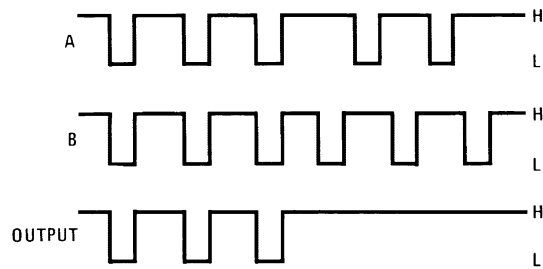

DS005824-52

Low output occurs only when inputs are low simultaneously.

FIGURE 22. In-Phase Detector

Physical Dimensions inches (millimeters) unless otherwise noted

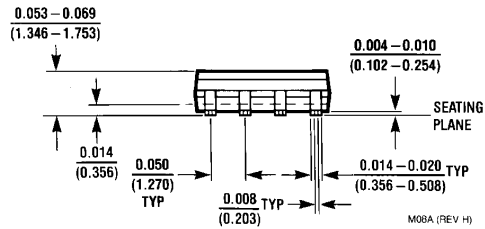
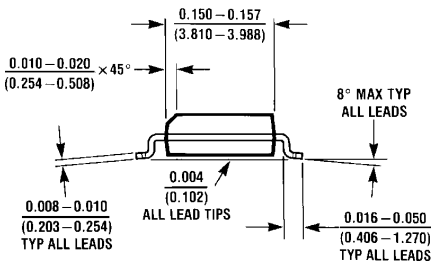
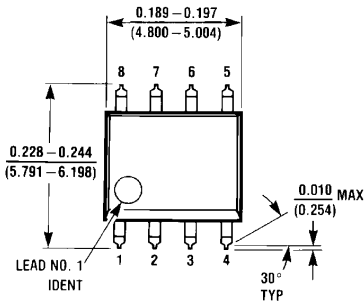

M08A (REV H)

SO Package (M)
 Order Number DS75451M, DS75452M, DS75453M
 NS Package Number M08A

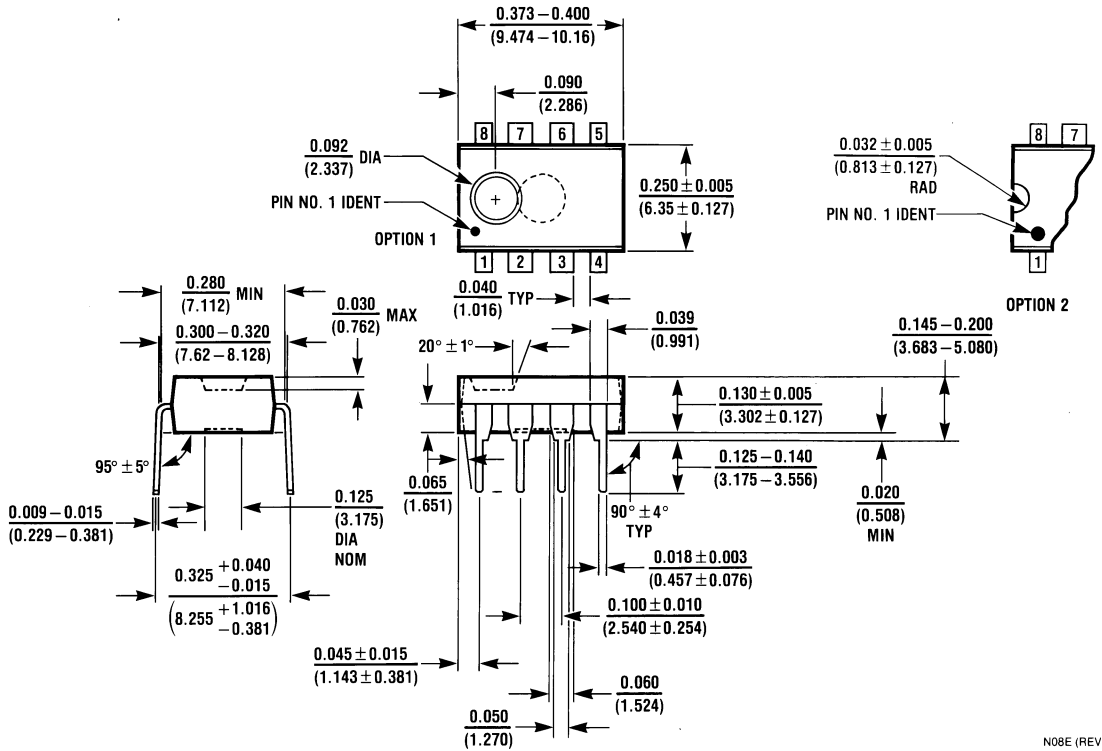

N08E (REV F)

Molded Dual-In-Line Package (N)
 Order Number DS75451N, DS75452N, DS75453N
 NS Package Number N08E

Notes

LIFE SUPPORT POLICY

NATIONAL'S PRODUCTS ARE NOT AUTHORIZED FOR USE AS CRITICAL COMPONENTS IN LIFE SUPPORT DEVICES OR SYSTEMS WITHOUT THE EXPRESS WRITTEN APPROVAL OF THE PRESIDENT AND GENERAL COUNSEL OF NATIONAL SEMICONDUCTOR CORPORATION. As used herein:

1. Life support devices or systems are devices or systems which, (a) are intended for surgical implant into the body, or (b) support or sustain life, and whose failure to perform when properly used in accordance with instructions for use provided in the labeling, can be reasonably expected to result in a significant injury to the user.
2. A critical component is any component of a life support device or system whose failure to perform can be reasonably expected to cause the failure of the life support device or system, or to affect its safety or effectiveness.



National Semiconductor Corporation
Americas
Email: support@nsc.com

www.national.com

National Semiconductor Europe

Fax: +49 (0) 180-530 85 86
Email: europe.support@nsc.com
Deutsch Tel: +49 (0) 69 9508 6208
English Tel: +44 (0) 870 24 0 2171
Français Tel: +33 (0) 1 41 91 8790

National Semiconductor Asia Pacific Customer Response Group

Tel: 65-2544466
Fax: 65-2504466
Email: ap.support@nsc.com

National Semiconductor Japan Ltd.

Tel: 81-3-5639-7560
Fax: 81-3-5639-7507

IMPORTANT NOTICE

Texas Instruments Incorporated and its subsidiaries (TI) reserve the right to make corrections, modifications, enhancements, improvements, and other changes to its products and services at any time and to discontinue any product or service without notice. Customers should obtain the latest relevant information before placing orders and should verify that such information is current and complete. All products are sold subject to TI's terms and conditions of sale supplied at the time of order acknowledgment.

TI warrants performance of its hardware products to the specifications applicable at the time of sale in accordance with TI's standard warranty. Testing and other quality control techniques are used to the extent TI deems necessary to support this warranty. Except where mandated by government requirements, testing of all parameters of each product is not necessarily performed.

TI assumes no liability for applications assistance or customer product design. Customers are responsible for their products and applications using TI components. To minimize the risks associated with customer products and applications, customers should provide adequate design and operating safeguards.

TI does not warrant or represent that any license, either express or implied, is granted under any TI patent right, copyright, mask work right, or other TI intellectual property right relating to any combination, machine, or process in which TI products or services are used. Information published by TI regarding third-party products or services does not constitute a license from TI to use such products or services or a warranty or endorsement thereof. Use of such information may require a license from a third party under the patents or other intellectual property of the third party, or a license from TI under the patents or other intellectual property of TI.

Reproduction of TI information in TI data books or data sheets is permissible only if reproduction is without alteration and is accompanied by all associated warranties, conditions, limitations, and notices. Reproduction of this information with alteration is an unfair and deceptive business practice. TI is not responsible or liable for such altered documentation. Information of third parties may be subject to additional restrictions.

Resale of TI products or services with statements different from or beyond the parameters stated by TI for that product or service voids all express and any implied warranties for the associated TI product or service and is an unfair and deceptive business practice. TI is not responsible or liable for any such statements.

TI products are not authorized for use in safety-critical applications (such as life support) where a failure of the TI product would reasonably be expected to cause severe personal injury or death, unless officers of the parties have executed an agreement specifically governing such use. Buyers represent that they have all necessary expertise in the safety and regulatory ramifications of their applications, and acknowledge and agree that they are solely responsible for all legal, regulatory and safety-related requirements concerning their products and any use of TI products in such safety-critical applications, notwithstanding any applications-related information or support that may be provided by TI. Further, Buyers must fully indemnify TI and its representatives against any damages arising out of the use of TI products in such safety-critical applications.

TI products are neither designed nor intended for use in military/aerospace applications or environments unless the TI products are specifically designated by TI as military-grade or "enhanced plastic." Only products designated by TI as military-grade meet military specifications. Buyers acknowledge and agree that any such use of TI products which TI has not designated as military-grade is solely at the Buyer's risk, and that they are solely responsible for compliance with all legal and regulatory requirements in connection with such use.

TI products are neither designed nor intended for use in automotive applications or environments unless the specific TI products are designated by TI as compliant with ISO/TS 16949 requirements. Buyers acknowledge and agree that, if they use any non-designated products in automotive applications, TI will not be responsible for any failure to meet such requirements.

Following are URLs where you can obtain information on other Texas Instruments products and application solutions:

Products

Audio	www.ti.com/audio
Amplifiers	amplifier.ti.com
Data Converters	dataconverter.ti.com
DLP® Products	www.dlp.com
DSP	dsp.ti.com
Clocks and Timers	www.ti.com/clocks
Interface	interface.ti.com
Logic	logic.ti.com
Power Mgmt	power.ti.com
Microcontrollers	microcontroller.ti.com
RFID	www.ti-rfid.com
OMAP Mobile Processors	www.ti.com/omap
Wireless Connectivity	www.ti.com/wirelessconnectivity

Applications

Communications and Telecom	www.ti.com/communications
Computers and Peripherals	www.ti.com/computers
Consumer Electronics	www.ti.com/consumer-apps
Energy and Lighting	www.ti.com/energy
Industrial	www.ti.com/industrial
Medical	www.ti.com/medical
Security	www.ti.com/security
Space, Avionics and Defense	www.ti.com/space-avionics-defense
Transportation and Automotive	www.ti.com/automotive
Video and Imaging	www.ti.com/video

TI E2E Community Home Page

e2e.ti.com

Mailing Address: Texas Instruments, Post Office Box 655303, Dallas, Texas 75265
Copyright © 2011, Texas Instruments Incorporated

Looking for pricing, stock, or lifecycle information?

Click below to explore more details on WIN SOURCE:

 [View DS75452MX](#) on WIN SOURCE

 [Texas Instruments](#) Information

Optimize Your Supply Chain with WIN SOURCE Solutions

-  Global Sourcing Solution
-  Obsolete Management
-  Cost Control Management
-  Shortage Management
-  Alternative Solution
-  Excess Inventory Management