



THE DATASHEET OF
1123000000



TERMSERIES TRS 24VDC 1CO AU

Weidmüller Interface GmbH & Co. KG
 Klingenbergstraße 16
 D-32758 Detmold
 Germany
 Fon: +49 5231 14-0
 Fax: +49 5231 14-292083
 www.weidmueller.com



TERMSERIES relay module 1 CO, complete modules consisting of a relay and a base with AC/DC/UC coils, available in different versions:

- With screw connection
- AgNi contact with hard gold-plated contacts
- Optionally with multiple-voltage input: 24...230 V UC
- With various protective circuits in the input (free-wheel diode, RC element)
- Illuminated ejection lever

General ordering data

Order No.	1123000000
Type	TRS 24VDC 1CO AU
Version	TERMSERIES, Relays, No. of contacts: 1, CO contact, AgNi 5µm Au, Rated control voltage: 24 V DC ±20 %, Continuous current: 6 A, Screw connection
GTIN (EAN)	4032248905256
Qty.	10 pc(s).

TERMSERIES
TRS 24VDC 1CO AU

Weidmüller Interface GmbH & Co. KG
 Klingenbergstraße 16
 D-32758 Detmold
 Germany
 Fon: +49 5231 14-0
 Fax: +49 5231 14-292083
 www.weidmueller.com

Technical data
Dimensions and weights

Width	6.4 mm	Height	90 mm
Depth	88 mm	Net weight	33 g

Temperatures

Humidity	5–95% rel. humidity, $T_u = 40^\circ\text{C}$, no condensation	Operating temperature	-40 °C...+60 °C
Storage temperature	-40 °C...+85 °C		

Input

Protective circuit	Integrated free-wheel diode, Reverse polarity protection	Rated control voltage	24 V DC $\pm 20\%$
Rated current DC	10 mA	Power rating	240 mW
Pull-in (sparkover) / drop-out voltage DC coil	16.6 V / 5 V	Pull-in / drop-out current, DC coil	7 mA / 2 mA
Status indicator	Green LED		

Output

Rated switching voltage	250 V AC	Max. switching voltage, AC	250 V
Max. switching voltage, DC	250 V	Continuous current	6 A
Making current	6 A	Max. switching power	1500 VA
Switch-on delay	< 6 ms	Switch-off delay	< 7 ms
Min. switching power	1 V / 1 mA	Max. switching frequency at rated load	0.1 Hz

Contact specifications

No. of contacts	1	Contact design	CO contact
Contact material	AgNi 5 μm Au	Mechanical service life	5 x 10 ⁶ switching cycles

general data

Wire connection method	Screw connection	Humidity	5–95% rel. humidity, $T_u = 40^\circ\text{C}$, no condensation
------------------------	------------------	----------	-----------------------------------------------------------------

Insulation coordination

Creepage and clearance distance input – output	≥ 5.5 mm	Rated voltage	300 V
Dielectric strength to mounting rail	4 kV _{eff} / 1 min.	Impulse withstand voltage	6 kV (1.2/50 μs)
Pollution severity	2	Surge voltage category	III

Other technical data

Version	Relay coupler	Protective circuit	Integrated free-wheel diode, Reverse polarity protection
Status indicator	Green LED		

Further details of approvals / standards

Standards	DIN EN 50178
-----------	--------------

Data sheet...

**TERMSERIES
TRS 24VDC 1CO AU**

Weidmüller Interface GmbH & Co. KG
 Klingenbergstraße 16
 D-32758 Detmold
 Germany
 Fon: +49 5231 14-0
 Fax: +49 5231 14-292083
 www.weidmueller.com

Technical data

Connection data

Clamping range, rated connection	1.5 mm ²	Clamping range, rated connection, max.	1.5 mm ²
Clamping range, rated connection, min.	0.14 mm ²	Stripping length, rated connection	8 mm
Tightening torque, min.	0.4 Nm	Wire connection method	Screw connection

Classifications

eClass 6.2	27-37-16-01	eClass 7.1	27-37-16-01
------------	-------------	------------	-------------

Approvals

Approvals



Downloads

Declaration of Conformity	K438_10_12.pdf
PDF	Installationsanleitung
3-D model	

**TERMSERIES
TRS 24VDC 1CO AU**

Weidmüller Interface GmbH & Co. KG
 Klingenbergstraße 16
 D-32758 Detmold
 Germany
 Fon: +49 5231 14-0
 Fax: +49 5231 14-292083
 www.weidmueller.com

Drawings

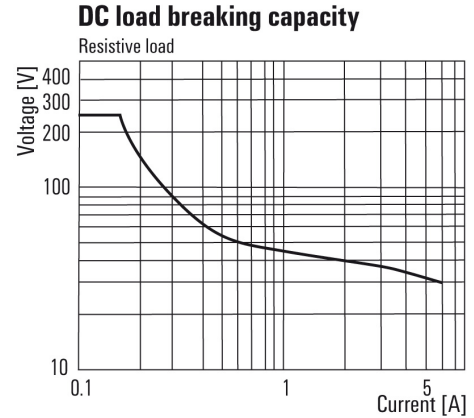
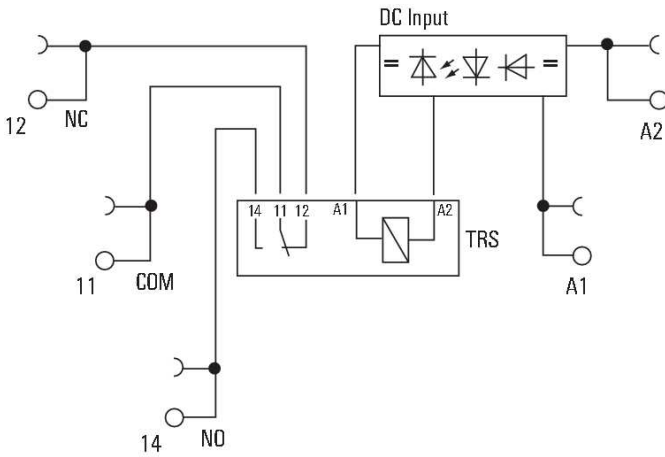

Electrical endurance

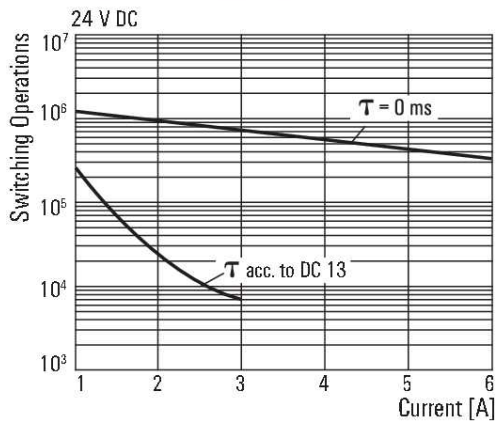

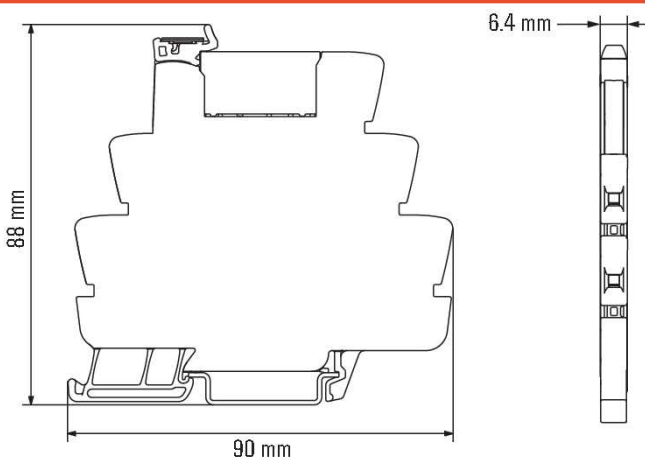
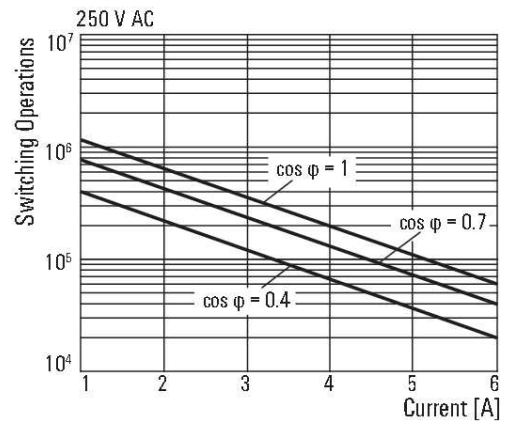

Electrical endurance



Looking for pricing, stock, or lifecycle information?

Click below to explore more details on WIN SOURCE:

-  [View 1123000000 on WIN SOURCE](#)
-  [Weidmuller Information](#)

Optimize Your Supply Chain with WIN SOURCE Solutions

-  Global Sourcing Solution
-  Obsolete Management
-  Cost Control Management
-  Shortage Management
-  Alternative Solution
-  Excess Inventory Management