



**THE DATASHEET OF
DS90LV049TMT**



DS90LV049 3V LVDS Dual Line Driver with Dual Line Receiver

Check for Samples: [DS90LV049](#)

FEATURES

- Up to 400 Mbps Switching Rates
- Flow-Through Pinout Simplifies PCB Layout
- 50 ps Typical Driver Channel-to-Channel Skew
- 50 ps Typical Receiver Channel-to-Channel Skew
- 3.3 V Single Power Supply Design
- TRI-STATE Output Control
- Internal Fail-Safe Biasing of Receiver Inputs
- Low Power Dissipation (70 mW at 3.3 V Static)
- High Impedance on LVDS Outputs on Power Down
- Conforms to TIA/EIA-644-A LVDS Standard
- Industrial Operating Temperature Range (–40°C to +85°C)
- Available in Low Profile 16 Pin TSSOP Package

DESCRIPTION

The DS90LV049 is a dual CMOS flow-through differential line driver-receiver pair designed for applications requiring ultra low power dissipation, exceptional noise immunity, and high data throughput. The device is designed to support data rates in excess of 400 Mbps utilizing Low Voltage Differential Signaling (LVDS) technology.

The DS90LV049 drivers accept LVTTTL/LVCMOS signals and translate them to LVDS signals. On the other hand, the receivers accept LVDS signals and translate them to 3 V CMOS signals. The LVDS input buffers have internal failsafe biasing that places the outputs to a known H (high) state for floating receiver inputs. In addition, the DS90LV049 supports a TRI-STATE function for a low idle power state when the device is not in use.

The EN and $\overline{\text{EN}}$ inputs are ANDed together and control the TRI-STATE outputs. The enables are common to all four gates.

Connection Diagram

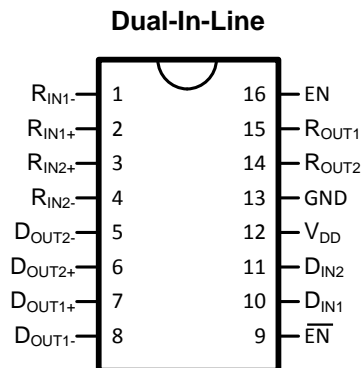

Order Number DS90LV049TMT
Order Number DS90LV049TMTX (Tape and Reel)
PW0016A Package



Please be aware that an important notice concerning availability, standard warranty, and use in critical applications of Texas Instruments semiconductor products and disclaimers thereto appears at the end of this data sheet.

All trademarks are the property of their respective owners.

Functional Diagram

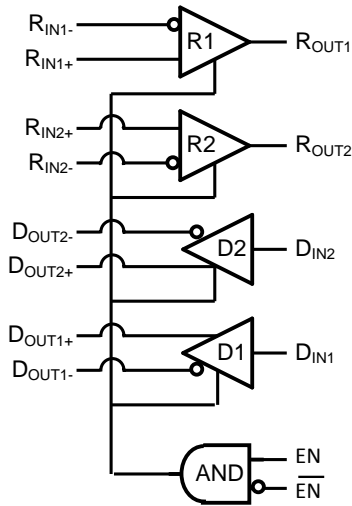

Table 1. TRUTH TABLE

EN	$\overline{\text{EN}}$	LVDS Out	LVC MOS Out
L or Open	L or Open	OFF	OFF
H	L or Open	ON	ON
L or Open	H	OFF	OFF
H	H	OFF	OFF



These devices have limited built-in ESD protection. The leads should be shorted together or the device placed in conductive foam during storage or handling to prevent electrostatic damage to the MOS gates.

ABSOLUTE MAXIMUM RATINGS⁽¹⁾⁽²⁾

Supply Voltage (V_{DD})	-0.3 V to +4 V
LVC MOS Input Voltage (D_{IN})	-0.3 V to ($V_{DD} + 0.3$ V)
LVDS Input Voltage (R_{IN+} , R_{IN-})	-0.3 V to +3.9 V
Enable Input Voltage (EN , \overline{EN})	-0.3 V to ($V_{DD} + 0.3$ V)
LVC MOS Output Voltage (R_{OUT})	-0.3 V to ($V_{DD} + 0.3$ V)
LVDS Output Voltage (D_{OUT+} , D_{OUT-})	-0.3 V to +3.9 V
LVC MOS Output Short Circuit Current (R_{OUT})	100 mA
LVDS Output Short Circuit Current (D_{OUT+} , D_{OUT-})	24 mA
LVDS Output Short Circuit Current Duration (D_{OUT+} , D_{OUT-})	Continuous
Storage Temperature Range	-65°C to +150°C
Lead Temperature Range	
Soldering (4 sec.)	+260°C
Maximum Junction Temperature	+150°C
Maximum Package Power Dissipation @ +25°C	
PW0016A Package	866 mW
Derate PW0016A Package	6.9 mW/°C above +25°C
ESD Rating	
(HBM, 1.5 k Ω , 100 pF)	≥ 7 kV
(MM, 0 Ω , 200 pF)	≥ 250 V

- (1) "Absolute Maximum Ratings" are those values beyond which the safety of the device cannot be specified. They are not meant to imply that the devices should be operated at these limits. [ELECTRICAL CHARACTERISTICS](#) specifies conditions of device operation.
- (2) If Military/Aerospace specified devices are required, please contact the Texas Instruments Sales Office/Distributors for availability and specifications.

RECOMMENDED OPERATING CONDITIONS

	Min	Typ	Max	Units
Supply Voltage (V_{DD})	+3.0	+3.3	+3.6	V
Operating Free Air Temperature (T_A)	-40	+25	+85	°C

ELECTRICAL CHARACTERISTICS

 Over supply voltage and operating temperature ranges, unless otherwise specified. ⁽¹⁾⁽²⁾⁽³⁾

Symbol	Parameter	Conditions	Pin	Min	Typ	Max	Units
LVC MOS Input DC Specifications (Driver Inputs, ENABLE Pins)							
V_{IH}	Input High Voltage		D_{IN} EN \overline{EN}	2.0		V_{DD}	V
V_{IL}	Input Low Voltage			GND		0.8	V
I_{IH}	Input High Current	$V_{IN} = V_{DD}$		-10	1	+10	μ A
I_{IL}	Input Low Current	$V_{IN} = GND$		-10	-0.1	+10	μ A
V_{CL}	Input Clamp Voltage	$I_{CL} = -18$ mA		-1.5	-0.6		V
LVDS Output DC Specifications (Driver Outputs)							

- (1) Current into device pins is defined as positive. Current out of device pins is defined as negative. All voltages are referenced to ground except: V_{TH} , V_{TL} , V_{OD} and ΔV_{OD} .
- (2) All typical values are given for: $V_{DD} = +3.3$ V, $T_A = +25$ °C.
- (3) The DS90LV049's drivers are current mode devices and only function within datasheet specifications when a resistive load is applied to their outputs. The typical range of the resistor values is 90 Ω to 110 Ω .

ELECTRICAL CHARACTERISTICS (continued)

Over supply voltage and operating temperature ranges, unless otherwise specified.⁽¹⁾⁽²⁾⁽³⁾

Symbol	Parameter	Conditions	Pin	Min	Typ	Max	Units		
$ V_{OD} $	Differential Output Voltage	$R_L = 100\ \Omega$ (Figure 1)	D_{OUT-} D_{OUT+}	250	350	450	mV		
ΔV_{OD}	Change in Magnitude of V_{OD} for Complementary Output States				1	35	mV		
V_{OS}	Offset Voltage			1.125	1.23	1.375	V		
ΔV_{OS}	Change in Magnitude of V_{OS} for Complementary Output States				1	25	mV		
I_{OS}	Output Short Circuit Current ⁽⁴⁾			ENABLED, $D_{IN} = V_{DD}$, $D_{OUT+} = 0\ V$ or $D_{IN} = GND$, $D_{OUT-} = 0\ V$		-5.8	-9.0	mA	
I_{OSD}	Differential Output Short Circuit Current ⁽⁴⁾			ENABLED, $V_{OD} = 0\ V$		-5.8	-9.0	mA	
I_{OFF}	Power-off Leakage			$V_{OUT} = 0\ V$ or $3.6\ V$ $V_{DD} = 0\ V$ or Open		-20	± 1	+20	μA
I_{OZ}	Output TRI-STATE Current			$EN = 0\ V$ and $\overline{EN} = V_{DD}$ $V_{OUT} = 0\ V$ or V_{DD}		-10	± 1	+10	μA
LVDS Input DC Specifications (Receiver Inputs)									
V_{TH}	Differential Input High Threshold	$V_{CM} = 1.2\ V, 0.05\ V, 2.35\ V$	R_{IN+} R_{IN-}		-15	35	mV		
V_{TL}	Differential Input Low Threshold			-100	-15		mV		
V_{CMR}	Common-Mode Voltage Range			0.05		3	V		
I_{IN}	Input Current	$V_{DD}=3.6\ V$ $V_{IN}=0\ V$ or $2.8\ V$		-12	± 4	+12	μA		
		$V_{DD}=0\ V$ $V_{IN}=0\ V$ or $2.8\ V$ or $3.6\ V$		-10	± 1	+10	μA		
LVC MOS Output DC Specifications (Receiver Outputs)									
V_{OH}	Output High Voltage	$I_{OH} = -0.4\ mA$, $V_{ID} = 200\ mV$	R_{OUT}	2.7	3.3		V		
V_{OL}	Output Low Voltage	$I_{OL} = 2\ mA$, $V_{ID} = 200\ mV$			0.05	0.25	V		
I_{OZ}	Output TRI-STATE Current	Disabled, $V_{OUT} = 0\ V$ or V_{DD}			-10	± 1	+10	μA	
General DC Specifications									
I_{DD}	Power Supply Current ⁽⁵⁾	$EN = 3.3\ V$	V_{DD}		21	35	mA		
I_{DDZ}	TRI-State Supply Current	$EN = 0\ V$			15	25	mA		

(4) Output short circuit current (I_{OS}) is specified as magnitude only, minus sign indicates direction only.

(5) Both driver and receiver inputs are static. All LVDS outputs have $100\ \Omega$ load. All LVC MOS outputs are floating. None of the outputs have any lumped capacitive load.

SWITCHING CHARACTERISTICS

 $V_{DD} = +3.3V \pm 10\%$, $T_A = -40^\circ\text{C}$ to $+85^\circ\text{C}^{(1)}$ ⁽²⁾

Symbol	Parameter	Conditions	Min	Typ	Max	Units
LVDS Outputs (Driver Outputs)						
t_{PHLD}	Differential Propagation Delay High to Low	$R_L = 100\ \Omega$ (Figure 2 and Figure 3)		0.7	2	ns
t_{PLHD}	Differential Propagation Delay Low to High			0.7	2	ns
t_{SKD1}	Differential Pulse Skew $ t_{PHLD} - t_{PLHD} ^{(3)(4)}$		0	0.05	0.4	ns
t_{SKD2}	Differential Channel-to-Channel Skew ⁽³⁾⁽⁵⁾		0	0.05	0.5	ns
t_{SKD3}	Differential Part-to-Part Skew ⁽³⁾⁽⁶⁾		0		1.0	ns
t_{TLH}	Rise Time ⁽³⁾		0.2	0.4	1	ns
t_{THL}	Fall Time ⁽³⁾		0.2	0.4	1	ns
t_{PHZ}	Disable Time High to Z	$R_L = 100\ \Omega$ (Figure 4 and Figure 5)		1.5	3	ns
t_{PLZ}	Disable Time Low to Z			1.5	3	ns
t_{PZH}	Enable Time Z to High		1	3	6	ns
t_{PZL}	Enable Time Z to Low		1	3	6	ns
f_{MAX}	Maximum Operating Frequency ⁽⁷⁾		200	250		MHz
LVCMOS Outputs (Receiver Outputs)						
t_{PHL}	Propagation Delay High to Low	(Figure 6 and Figure 7)	0.5	2	3.5	ns
t_{PLH}	Propagation Delay Low to High		0.5	2	3.5	ns
t_{SK1}	Pulse Skew $ t_{PHL} - t_{PLH} ^{(8)}$		0	0.05	0.4	ns
t_{SK2}	Channel-to-Channel Skew ⁽⁹⁾		0	0.05	0.5	ns
t_{SK3}	Part-to-Part Skew ⁽¹⁰⁾		0		1.0	ns
t_{TLH}	Rise Time ⁽³⁾		0.3	0.9	1.4	ns
t_{THL}	Fall Time ⁽³⁾	0.3	0.75	1.4	ns	
t_{PHZ}	Disable Time High to Z	(Figure 8 and Figure 9)	3	5.6	8	ns
t_{PLZ}	Disable Time Low to Z		3	5.4	8	ns
t_{PZH}	Enable Time Z to High		2.5	4.6	7	ns
t_{PZL}	Enable Time Z to Low		2.5	4.6	7	ns
f_{MAX}	Maximum Operating Frequency ⁽¹¹⁾		200	250		MHz

(1) All typical values are given for: $V_{DD} = +3.3\text{ V}$, $T_A = +25^\circ\text{C}$.

(2) Generator waveform for all tests unless otherwise specified: $f = 1\text{ MHz}$, $Z_O = 50\ \Omega$, $t_r \leq 1\text{ ns}$, and $t_f \leq 1\text{ ns}$.

(3) These parameters are specified by design. The limits are based on statistical analysis of the device performance over PVT (process, voltage, temperature) ranges.

(4) t_{SKD1} or differential pulse skew is defined as $|t_{PHLD} - t_{PLHD}|$. It is the magnitude difference in the differential propagation delays between the positive going edge and the negative going edge of the same driver channel.

(5) t_{SKD2} or differential channel-to-channel skew is defined as the magnitude difference in the differential propagation delays between two driver channels on the same device.

(6) t_{SKD3} or differential part-to-part skew is defined as $|t_{PLHD\ Max} - t_{PLHD\ Min}|$ or $|t_{PHLD\ Max} - t_{PHLD\ Min}|$. It is the difference between the minimum and maximum specified differential propagation delays. This specification applies to devices at the same V_{DD} and within 5°C of each other within the operating temperature range.

(7) f_{MAX} generator input conditions: $t_r = t_f < 1\text{ ns}$ (0% to 100%), 50% duty cycle, 0 V to 3 V. Output Criteria: duty cycle = 45%/55%, $V_{OD} > 250\text{ mV}$, all channels switching.

(8) t_{SK1} or pulse skew is defined as $|t_{PHL} - t_{PLH}|$. It is the magnitude difference in the propagation delays between the positive going edge and the negative going edge of the same receiver channel.

(9) t_{SK2} or channel-to-channel skew is defined as the magnitude difference in the propagation delays between two receiver channels on the same device.

(10) t_{SK3} or part-to-part skew is defined as $|t_{PLH\ Max} - t_{PLH\ Min}|$ or $|t_{PHL\ Max} - t_{PHL\ Min}|$. It is the difference between the minimum and maximum specified propagation delays. This specification applies to devices at the same V_{DD} and within 5°C of each other within the operating temperature range.

(11) f_{MAX} generator input conditions: $t_r = t_f < 1\text{ ns}$ (0% to 100%), 50% duty cycle, $V_{ID} = 200\text{ mV}$, $V_{CM} = 1.2\text{ V}$. Output Criteria: duty cycle = 45%/55%, $V_{OH} > 2.7\text{ V}$, $V_{OL} < 0.25\text{ V}$, all channels switching.

PARAMETER MEASUREMENT INFORMATION

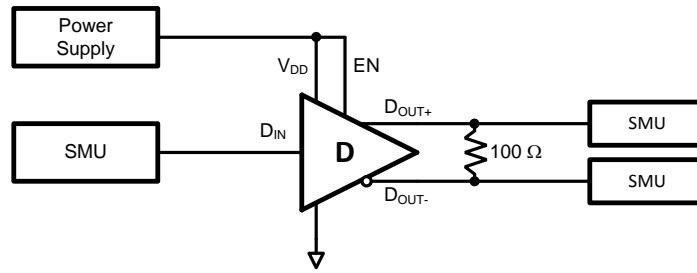

Figure 1. Driver V_{OD} and V_{OS} Test Circuit

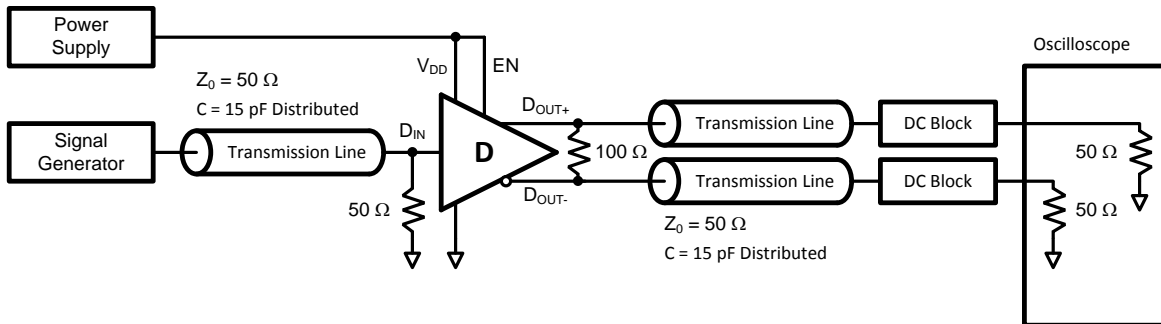

Figure 2. Driver Propagation Delay and Transition Time Test Circuit

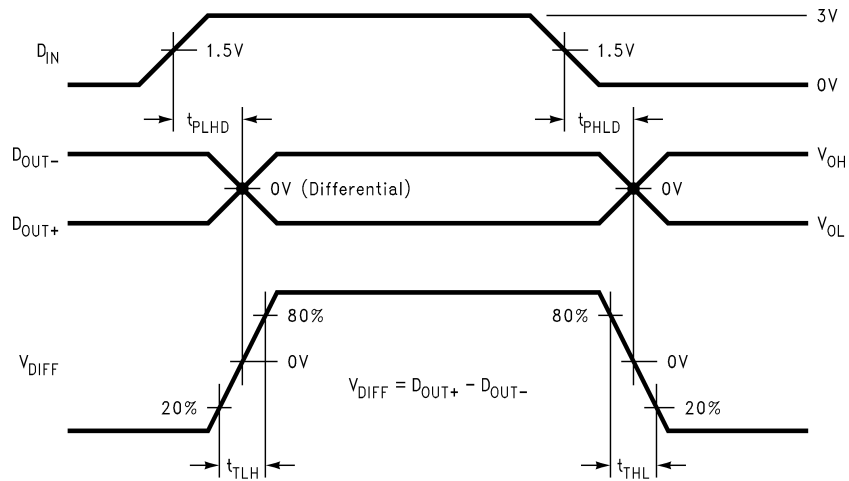

Figure 3. Driver Propagation Delay and Transition Time Waveforms

PARAMETER MEASUREMENT INFORMATION (continued)

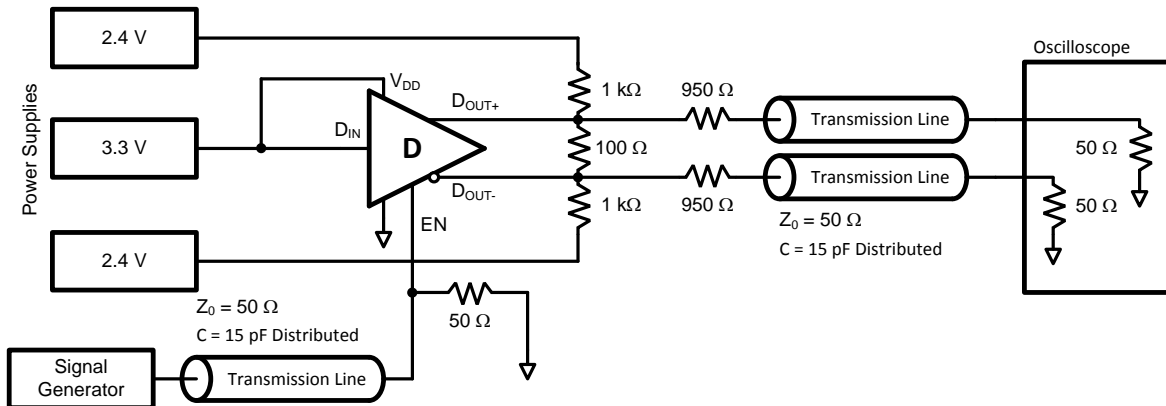

Figure 4. Driver TRI-STATE Delay Test Circuit

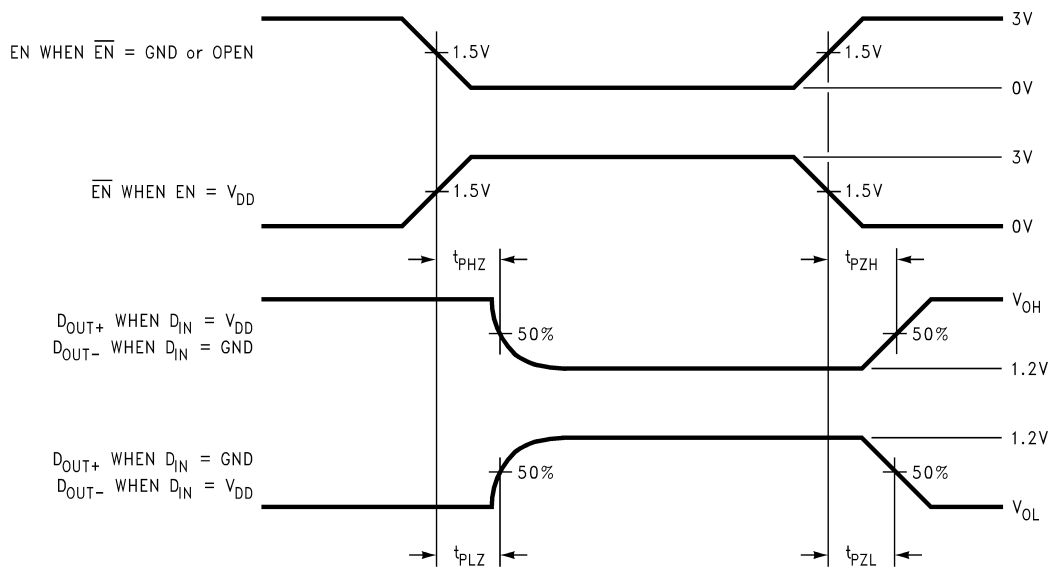

Figure 5. Driver TRI-STATE Delay Waveform

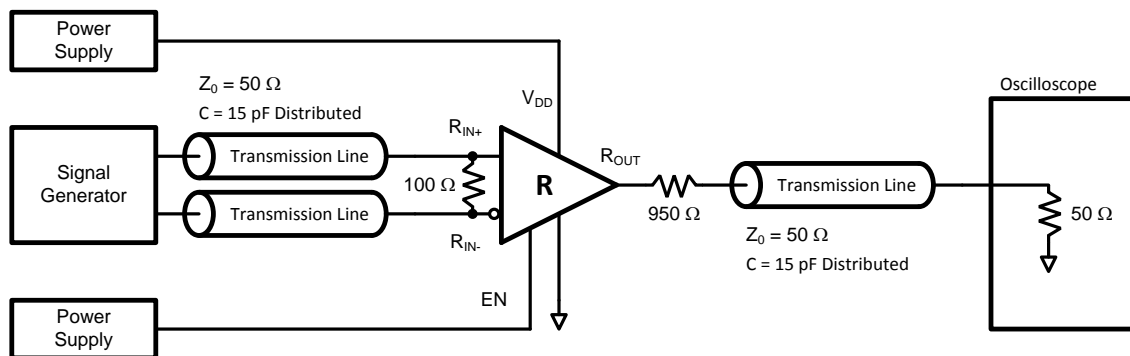

Figure 6. Receiver Propagation Delay and Transition Time Test Circuit

PARAMETER MEASUREMENT INFORMATION (continued)

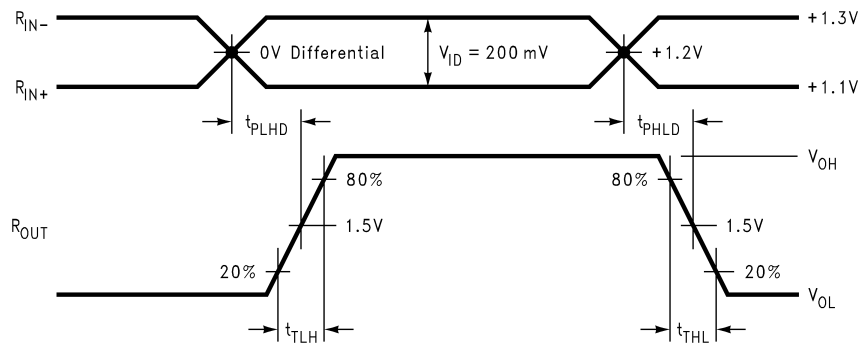

Figure 7. Receiver Propagation Delay and Transition Time Waveforms

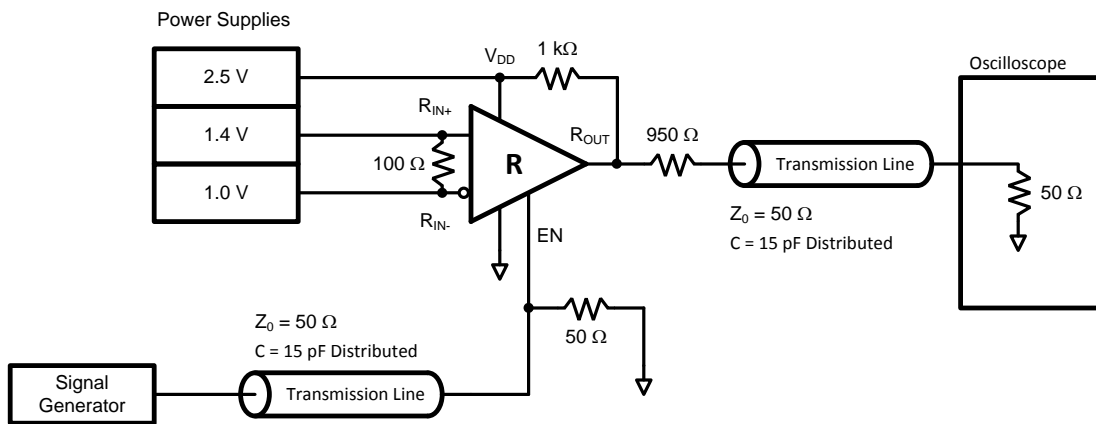

Figure 8. Receiver TRI-STATE Delay Test Circuit

PARAMETER MEASUREMENT INFORMATION (continued)

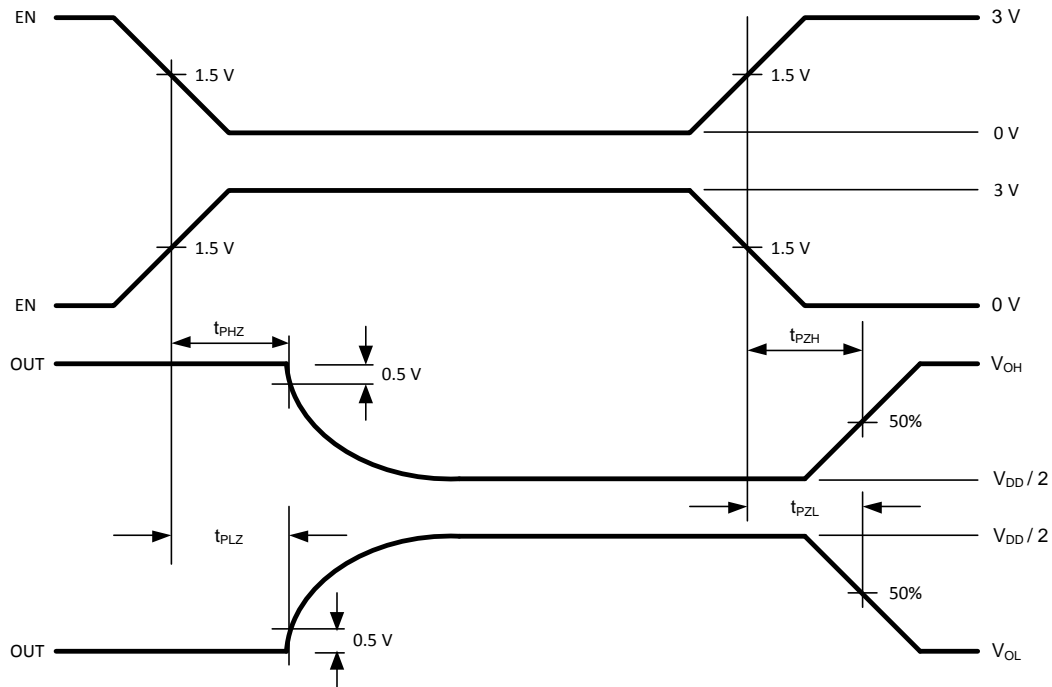

Figure 9. Receiver TRI-STATE Delay Waveforms

TYPICAL APPLICATION

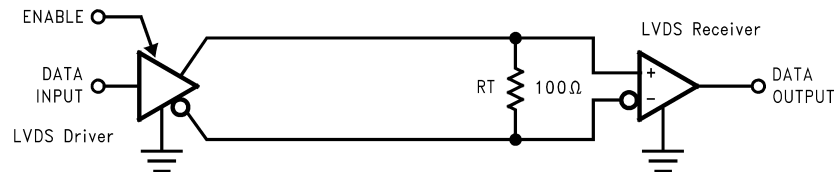

Figure 10. Point-to-Point Application

APPLICATION INFORMATION

General application guidelines and hints for LVDS drivers and receivers may be found in the following application notes: LVDS Owner's Manual (lit #550062-002), AN-808 ([SNLA028](#)), AN-977 ([SNLA166](#)), AN-971 ([SNLA165](#)), AN-916 ([SNLA219](#)), AN-805 ([SNOA233](#)), AN-903 ([SNLA034](#)).

LVDS drivers and receivers are intended to be primarily used in an uncomplicated point-to-point configuration as is shown in [Figure 10](#). This configuration provides a clean signaling environment for the fast edge rates of the drivers. The receiver is connected to the driver through a balanced media which may be a standard twisted pair cable, a parallel pair cable, or simply PCB traces. Typically, the characteristic differential impedance of the media is in the range of 100 Ω . A termination resistor of 100 Ω (selected to match the media), and is located as close to the receiver input pins as possible. The termination resistor converts the driver output current (current mode) into a voltage that is detected by the receiver. Other configurations are possible such as a multi-receiver configuration, but the effects of a mid-stream connector(s), cable stub(s), and other impedance discontinuities as well as ground shifting, noise margin limits, and total termination loading must be taken into account.

The TRI-STATE function allows the device outputs to be disabled, thus obtaining an even lower power state when the transmission of data is not required.

The DS90LV049 has a flow-through pinout that allows for easy PCB layout. The LVDS signals on one side of the device easily allows for matching electrical lengths of the differential pair trace lines between the driver and the receiver as well as allowing the trace lines to be close together to couple noise as common-mode. Noise isolation is achieved with the LVDS signals on one side of the device and the TTL signals on the other side.

POWER DECOUPLING RECOMMENDATIONS

Bypass capacitors must be used on power pins. Use high frequency ceramic (surface mount is recommended) 0.1 μF and 0.001 μF capacitors in parallel at the power supply pin with the smallest value capacitor closest to the device supply pin. Additional scattered capacitors over the printed circuit board will improve decoupling. Multiple vias should be used to connect the decoupling capacitors to the power planes. A 10 μF (35 V) or greater solid tantalum capacitor should be connected at the power entry point on the printed circuit board between the supply and ground.

PC BOARD CONSIDERATIONS

Use at least 4 PCB layers (top to bottom); LVDS signals, ground, power, TTL signals.

Isolate TTL signals from LVDS signals, otherwise the TTL may couple onto the LVDS lines. It is best to put TTL and LVDS signals on different layers which are isolated by a power/ground plane(s).

Keep drivers and receivers as close to the (LVDS port side) connectors as possible.

DIFFERENTIAL TRACES

Use controlled impedance traces which match the differential impedance of your transmission medium (i.e. cable) and termination resistor. Run the differential pair trace lines as close together as possible as soon as they leave the IC (stubs should be < 10 mm long). This will help eliminate reflections and ensure noise is coupled as common-mode. In fact, we have seen that differential signals which are 1 mm apart radiate far less noise than traces 3 mm apart since magnetic field cancellation is much better with the closer traces. In addition, noise induced on the differential lines is much more likely to appear as common-mode which is rejected by the receiver.

Match electrical lengths between traces to reduce skew. Skew between the signals of a pair means a phase difference between signals which destroys the magnetic field cancellation benefits of differential signals and EMI will result. (Note the velocity of propagation, $v = c/\epsilon_r$ where c (the speed of light) = 0.2997 mm/ps or 0.0118 in/ps). Do not rely solely on the autoroute function for differential traces. Carefully review dimensions to match differential impedance and provide isolation for the differential lines. Minimize the number of vias and other discontinuities on the line.

Avoid 90° turns (these cause impedance discontinuities). Use arcs or 45° bevels.

Within a pair of traces, the distance between the two traces should be minimized to maintain common-mode rejection of the receivers. On the printed circuit board, this distance should remain constant to avoid discontinuities in differential impedance. Minor violations at connection points are allowable.

TERMINATION

Use a termination resistor which best matches the differential impedance of your transmission line. The resistor should be between 90 Ω and 130 Ω . Remember that the current mode outputs need the termination resistor to generate the differential voltage. LVDS will not work without resistor termination. Typically, connecting a single resistor across the pair at the receiver end will suffice.

Surface mount 1% to 2% resistors are best. PCB stubs, component lead, and the distance from the termination to the receiver inputs should be minimized. The distance between the termination resistor and the receiver should be < 10 mm (12 mm MAX).

PROBING LVDS TRANSMISSION LINES

Always use high impedance (> 100 k Ω), low capacitance (< 2 pF) scope probes with a wide bandwidth (1 GHz) scope. Improper probing will give deceiving results.

CABLES AND CONNECTORS, GENERAL COMMENTS

When choosing cable and connectors for LVDS it is important to remember:

Use controlled impedance media. The cables and connectors you use should have a matched differential impedance of about 100 Ω . They should not introduce major impedance discontinuities.

Balanced cables (e.g. twisted pair) are usually better than unbalanced cables (ribbon cable, simple coax.) for noise reduction and signal quality. Balanced cables tend to generate less EMI due to field canceling effects and also tend to pick up electromagnetic radiation a common-mode (not differential mode) noise which is rejected by the receiver.

FAIL-SAFE FEATURE

An LVDS receiver is a high gain, high speed device that amplifies a small differential signal (20 mV) to CMOS logic levels. Due to the high gain and tight threshold of the receiver, care should be taken to prevent noise from appearing as a valid signal.

The receiver's internal fail-safe circuitry is designed to source/sink a small amount of current, providing fail-safe protection (a stable known state of HIGH output voltage) for floating receiver inputs.

The DS90LV049 has two receivers, and if an application requires a single receiver, the unused receiver inputs should be left OPEN. Do not tie unused receiver inputs to ground or any other voltages. The input is biased by internal high value pull up and pull down current sources to set the output to a HIGH state. This internal circuitry will ensure a HIGH, stable output state for open inputs.

External lower value pull up and pull down resistors (for a stronger bias) may be used to boost fail-safe in the presence of higher noise levels. The pull up and pull down resistors should be in the 5 k Ω to 15 k Ω range to minimize loading and waveform distortion to the driver. The common-mode bias point should be set to approximately 1.2 V (less than 1.75 V) to be compatible with the internal circuitry.

For more information on failsafe biasing of LVDS interfaces please refer to AN-1194 ([SNLA051](#)).

PIN DESCRIPTIONS

Pin No.	Name	Description
10, 11	D _{IN}	Driver input pins, LVCMOS levels. There is a pull-down current source present.
6, 7	D _{OUT+}	Non-inverting driver output pins, LVDS levels.
5, 8	D _{OUT-}	Inverting driver output pins, LVDS levels.
2, 3	R _{IN+}	Non-inverting receiver input pins, LVDS levels. There is a pull-up current source present.
1, 4	R _{IN-}	Inverting receiver input pins, LVDS levels. There is a pull-down current source present.
14, 15	R _{OUT}	Receiver output pins, LVCMOS levels.
9, 16	EN, $\overline{\text{EN}}$	Enable and Disable pins. There are pull-down current sources present at both pins.
12	V _{DD}	Power supply pin.
13	GND	Ground pin.

TYPICAL PERFORMANCE CURVES

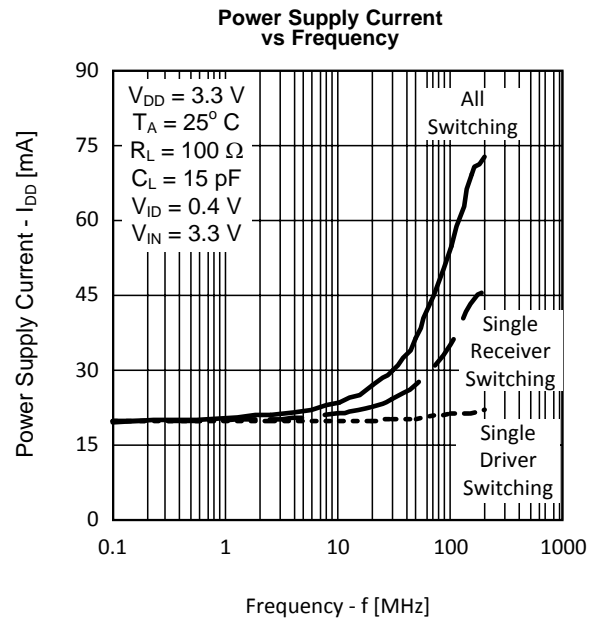
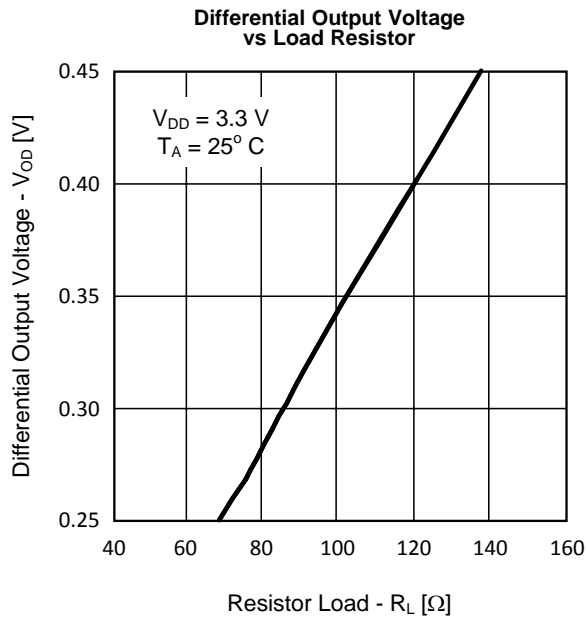

REVISION HISTORY

Changes from Revision C (April 2013) to Revision D	Page
<hr/> <ul style="list-style-type: none">• Changed layout of National Data Sheet to TI format	<hr/> 11

PACKAGING INFORMATION

Orderable Device	Status (1)	Package Type	Package Drawing	Pins	Package Qty	Eco Plan (2)	Lead/Ball Finish (6)	MSL Peak Temp (3)	Op Temp (°C)	Device Marking (4/5)	Samples
DS90LV049TMT	NRND	TSSOP	PW	16	92	TBD	Call TI	Call TI	-40 to 85	90LV049 TMT	
DS90LV049TMT/NOPB	ACTIVE	TSSOP	PW	16	92	Green (RoHS & no Sb/Br)	CU SN	Level-1-260C-UNLIM	-40 to 85	90LV049 TMT	Samples
DS90LV049TMTX/NOPB	ACTIVE	TSSOP	PW	16	2500	Green (RoHS & no Sb/Br)	CU SN	Level-1-260C-UNLIM	-40 to 85	90LV049 TMT	Samples

(1) The marketing status values are defined as follows:

ACTIVE: Product device recommended for new designs.

LIFEBUY: TI has announced that the device will be discontinued, and a lifetime-buy period is in effect.

NRND: Not recommended for new designs. Device is in production to support existing customers, but TI does not recommend using this part in a new design.

PREVIEW: Device has been announced but is not in production. Samples may or may not be available.

OBsolete: TI has discontinued the production of the device.

(2) Eco Plan - The planned eco-friendly classification: Pb-Free (RoHS), Pb-Free (RoHS Exempt), or Green (RoHS & no Sb/Br) - please check <http://www.ti.com/productcontent> for the latest availability information and additional product content details.

TBD: The Pb-Free/Green conversion plan has not been defined.

Pb-Free (RoHS): TI's terms "Lead-Free" or "Pb-Free" mean semiconductor products that are compatible with the current RoHS requirements for all 6 substances, including the requirement that lead not exceed 0.1% by weight in homogeneous materials. Where designed to be soldered at high temperatures, TI Pb-Free products are suitable for use in specified lead-free processes.

Pb-Free (RoHS Exempt): This component has a RoHS exemption for either 1) lead-based flip-chip solder bumps used between the die and package, or 2) lead-based die adhesive used between the die and leadframe. The component is otherwise considered Pb-Free (RoHS compatible) as defined above.

Green (RoHS & no Sb/Br): TI defines "Green" to mean Pb-Free (RoHS compatible), and free of Bromine (Br) and Antimony (Sb) based flame retardants (Br or Sb do not exceed 0.1% by weight in homogeneous material)

(3) MSL, Peak Temp. - The Moisture Sensitivity Level rating according to the JEDEC industry standard classifications, and peak solder temperature.

(4) There may be additional marking, which relates to the logo, the lot trace code information, or the environmental category on the device.

(5) Multiple Device Markings will be inside parentheses. Only one Device Marking contained in parentheses and separated by a "~" will appear on a device. If a line is indented then it is a continuation of the previous line and the two combined represent the entire Device Marking for that device.

(6) Lead/Ball Finish - Orderable Devices may have multiple material finish options. Finish options are separated by a vertical ruled line. Lead/Ball Finish values may wrap to two lines if the finish value exceeds the maximum column width.

Important Information and Disclaimer: The information provided on this page represents TI's knowledge and belief as of the date that it is provided. TI bases its knowledge and belief on information provided by third parties, and makes no representation or warranty as to the accuracy of such information. Efforts are underway to better integrate information from third parties. TI has taken and

continues to take reasonable steps to provide representative and accurate information but may not have conducted destructive testing or chemical analysis on incoming materials and chemicals. TI and TI suppliers consider certain information to be proprietary, and thus CAS numbers and other limited information may not be available for release.

In no event shall TI's liability arising out of such information exceed the total purchase price of the TI part(s) at issue in this document sold by TI to Customer on an annual basis.

TAPE AND REEL INFORMATION



QUADRANT ASSIGNMENTS FOR PIN 1 ORIENTATION IN TAPE



*All dimensions are nominal

Device	Package Type	Package Drawing	Pins	SPQ	Reel Diameter (mm)	Reel Width W1 (mm)	A0 (mm)	B0 (mm)	K0 (mm)	P1 (mm)	W (mm)	Pin1 Quadrant
DS90LV049TMTX/NOPB	TSSOP	PW	16	2500	330.0	12.4	6.95	5.6	1.6	8.0	12.0	Q1

TAPE AND REEL BOX DIMENSIONS



*All dimensions are nominal

Device	Package Type	Package Drawing	Pins	SPQ	Length (mm)	Width (mm)	Height (mm)
DS90LV049TMTX/NOPB	TSSOP	PW	16	2500	367.0	367.0	35.0



NOTES:

1. All linear dimensions are in millimeters. Any dimensions in parenthesis are for reference only. Dimensioning and tolerancing per ASME Y14.5M.
2. This drawing is subject to change without notice.
3. This dimension does not include mold flash, protrusions, or gate burrs. Mold flash, protrusions, or gate burrs shall not exceed 0.15 mm per side.
4. This dimension does not include interlead flash. Interlead flash shall not exceed 0.25 mm per side.
5. Reference JEDEC registration MO-153.

EXAMPLE BOARD LAYOUT

PW0016A

TSSOP - 1.2 mm max height

SMALL OUTLINE PACKAGE

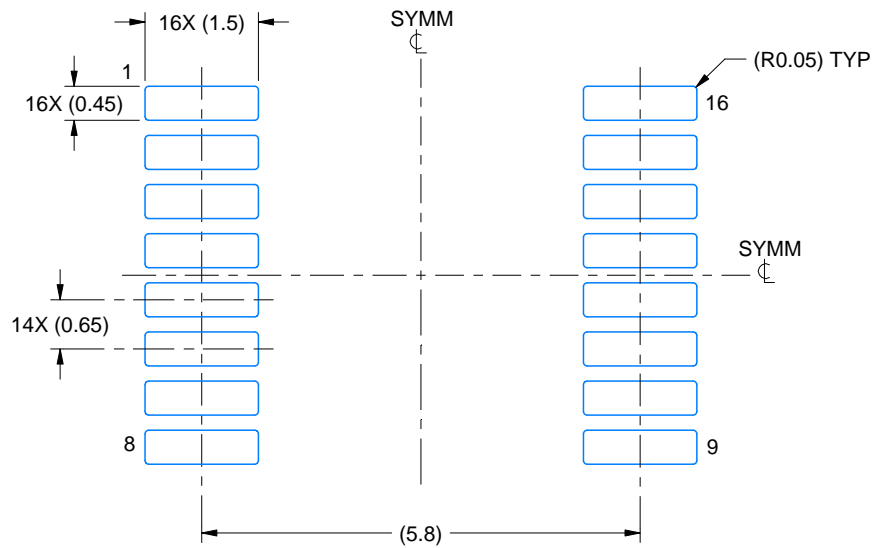

LAND PATTERN EXAMPLE
EXPOSED METAL SHOWN
SCALE: 10X



SOLDER MASK DETAILS

4220204/A 02/2017

NOTES: (continued)

- 6. Publication IPC-7351 may have alternate designs.
- 7. Solder mask tolerances between and around signal pads can vary based on board fabrication site.

EXAMPLE STENCIL DESIGN

PW0016A

TSSOP - 1.2 mm max height

SMALL OUTLINE PACKAGE

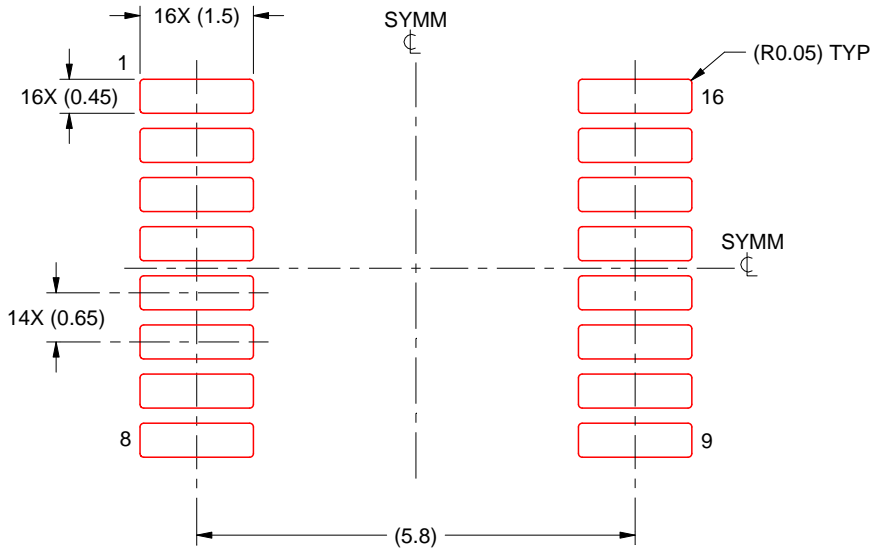

SOLDER PASTE EXAMPLE
BASED ON 0.125 mm THICK STENCIL
SCALE: 10X

4220204/A 02/2017

NOTES: (continued)

8. Laser cutting apertures with trapezoidal walls and rounded corners may offer better paste release. IPC-7525 may have alternate design recommendations.
9. Board assembly site may have different recommendations for stencil design.

IMPORTANT NOTICE AND DISCLAIMER

TI PROVIDES TECHNICAL AND RELIABILITY DATA (INCLUDING DATASHEETS), DESIGN RESOURCES (INCLUDING REFERENCE DESIGNS), APPLICATION OR OTHER DESIGN ADVICE, WEB TOOLS, SAFETY INFORMATION, AND OTHER RESOURCES "AS IS" AND WITH ALL FAULTS, AND DISCLAIMS ALL WARRANTIES, EXPRESS AND IMPLIED, INCLUDING WITHOUT LIMITATION ANY IMPLIED WARRANTIES OF MERCHANTABILITY, FITNESS FOR A PARTICULAR PURPOSE OR NON-INFRINGEMENT OF THIRD PARTY INTELLECTUAL PROPERTY RIGHTS.

These resources are intended for skilled developers designing with TI products. You are solely responsible for (1) selecting the appropriate TI products for your application, (2) designing, validating and testing your application, and (3) ensuring your application meets applicable standards, and any other safety, security, or other requirements. These resources are subject to change without notice. TI grants you permission to use these resources only for development of an application that uses the TI products described in the resource. Other reproduction and display of these resources is prohibited. No license is granted to any other TI intellectual property right or to any third party intellectual property right. TI disclaims responsibility for, and you will fully indemnify TI and its representatives against, any claims, damages, costs, losses, and liabilities arising out of your use of these resources.

TI's products are provided subject to TI's Terms of Sale (www.ti.com/legal/termsofsale.html) or other applicable terms available either on ti.com or provided in conjunction with such TI products. TI's provision of these resources does not expand or otherwise alter TI's applicable warranties or warranty disclaimers for TI products.

Mailing Address: Texas Instruments, Post Office Box 655303, Dallas, Texas 75265
Copyright © 2018, Texas Instruments Incorporated

Looking for pricing, stock, or lifecycle information?

Click below to explore more details on WIN SOURCE:

 [View DS90LV049TMT](#) on WIN SOURCE

 [Texas Instruments](#) Information

Optimize Your Supply Chain with WIN SOURCE Solutions

-  Global Sourcing Solution
-  Obsolete Management
-  Cost Control Management
-  Shortage Management
-  Alternative Solution
-  Excess Inventory Management