

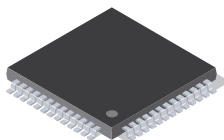

**THE DATASHEET OF
DSD1608PAHR**





8-CHANNEL, ENHANCED MULTIFORMAT, DELTA-SIGMA, DIGITAL-TO-ANALOG CONVERTER

FEATURES

- Supports DSD and PCM Formats
- Supports TDMCA
- Accepts 16-, 18-, 20- and 24-Bit Audio Data for PCM Format
- Analog Performance ($V_{CC} = 5\text{ V}$):
 - Dynamic Range: 108 dB, Typical
 - SNR: 108 dB, Typical
 - THD+N: 0.0012%, Typical
 - Full-Scale Output: $4 V_{pp}$, Typical
- Includes $8\times$ Oversampling Digital Filter for PCM Format:
 - Stopband Attenuation: -60 dB
 - Passband Ripple: $\pm 0.02\text{ dB}$
- Includes Digital DSD FILTER for DSD Format:
 - Passband: 50 kHz, 70 kHz, 60 kHz at -3 dB
- Sampling Frequency:
 - PCM Mode: 10 kHz to 200 kHz
 - DSD Mode: $64 \times 44.1\text{ kHz}$
- System Clock:
 - $128 f_S$, $192 f_S$, $256 f_S$, $384 f_S$, $512 f_S$, $768 f_S$
- Data Formats:
 - Standard, I²S, and Left-Justified for PCM Direct Stream Digital
- User-Programmable Mode Controls:
 - Digital Attenuation
 - Digital De-Emphasis

- Digital Filter Rolloff: Sharp or Slow Soft Mute
- Three Zero Flags
- Dual Supply Operation:
 - 5-V Analog, 3.3-V Digital
- Package: 52-Pin TQFP

APPLICATIONS

- Universal A/V Players
- SACD Players
- Car Audio Systems
- Other Applications Requiring 24-Bit Audio

DESCRIPTION

The DSD1608 is a CMOS, monolithic, 8-channel digital-to-analog converter which supports both PCM audio data format and direct stream digital (DSD) audio data format. The device includes an $8\times$ digital interpolation filter and a digital DSD filter with three selectable frequency-response curves, followed by Texas Instruments' enhanced multilevel delta-sigma modulator, which employs 4th-order noise shaping and 8-level amplitude quantization to achieve excellent dynamic performance and improved tolerance to clock jitter. Sampling rates up to 192 kHz for the PCM mode and $64 \times 44.1\text{ kHz}$ for the DSD mode are supported. A full set of user-programmable functions is accessible through a 4-wire serial control port, which supports register write and read functions. The DSD1608 supports the time-division-multiplexed command and audio data (TDMCA) format. The DSD1608 is available in a 52-pin TQFP package.



Please be aware that an important notice concerning availability, standard warranty, and use in critical applications of Texas Instruments semiconductor products and disclaimers thereto appears at the end of this data sheet.

DSD1608

SLES040 – JUNE 2002



This integrated circuit can be damaged by ESD. Texas Instruments recommends that all integrated circuits be handled with appropriate precautions. Failure to observe proper handling and installation procedures can cause damage.

ESD damage can range from subtle performance degradation to complete device failure. Precision integrated circuits may be more susceptible to damage because very small parametric changes could cause the device not to meet its published specifications.

ORDERING INFORMATION

PRODUCT	PACKAGE	PACKAGE DESIGNATOR	OPERATION TEMPERATURE RANGE	PACKAGE MARKING	ORDERING NUMBER	TRANSPORT MEDIA
DSD1608PAH	52-lead TQFP	PAH	-25°C to 85°C	DSD1608	DSD1608PAH	Tube
					DSD1608PAHR	Tape and reel

ABSOLUTE MAXIMUM RATINGS

over operating free-air temperature range unless otherwise noted⁽¹⁾

		DSD1608
Supply voltage	V _{CC1} -V _{CC7}	6.5 V
	V _{DD1} , V _{DD2}	4 V
Supply voltage differences: V _{CC1} -V _{CC7} , V _{DD1} , V _{DD2}		±0.1 V
Ground voltage differences: AGND1-6, DGND1, DGND2		±0.1 V
Digital input voltage: PLRCK, PBCK, PDATA1-PDATA4, DSD1-DSD8, DBCK, DSCK, PSCK, <u>RST</u>		-0.3 V to 6.5 V
Digital input voltage: MC, MS, MDI, ZERO1, ZERO2, ZERO38, MDO		-0.3 V to (V _{DD} + 0.3 V)
Analog input voltage		-0.3 V to (V _{CC} + 0.3 V)
Input current (any pins except supplies)		±10 mA
Operating temperature		-40°C to 85°C
Storage temperature		-55°C to 150°C
Junction temperature		150°C
Lead temperature (soldering)		260°C, 5 s
Package temperature (IR reflow, peak)		235°C, 10 s

(1) Stresses beyond those listed under “absolute maximum ratings” may cause permanent damage to the device. These are stress ratings only, and functional operation of the device at these or any other conditions beyond those indicated under “recommended operating conditions” is not implied. Exposure to absolute-maximum-rated conditions for extended periods may affect device reliability.

ELECTRICAL CHARACTERISTICS

at T_A = 25°C, V_{DD} = 3.3 V, V_{CC} = 5 V; in PCM mode, f_S = 44.1 kHz, system clock = 256 f_S, 24-bit data; in DSD mode, f_S = 2.8224 MHz (= 64 × 44.1 kHz), system clock = 256 × 44.1 kHz, 1-bit data (unless otherwise noted)

PARAMETER	TEST CONDITIONS	MIN	TYP	MAX	UNIT
Resolution			24		Bits
DATA FORMAT (PCM MODE)					
Audio data interface format		Standard, I ² S, left justified			
Audio data bit length		16-, 18-, 20-, 24-bit selectable			
Audio data format		MSB first, 2s complement			
f _S Sampling frequency	f _S = 44.1 kHz	10		200	kHz
System clock frequency		128 f _S , 192 f _S , 256 f _S , 384 f _S , 512 f _S , 768 f _S			
DATA FORMAT (DSD MODE)					
Audio data interface format		Direct stream digital (DSD)			
Audio data bit length		1 bit			
f _S Sampling frequency	f _S = 44.1 kHz		64 f _S		Hz
System clock frequency	f _S = 44.1 kHz	256 f _S , 384 f _S , 512 f _S , 768 f _S			kHz

(1) Pins 50, 51, 34, 33, 37, 38-45, 46-49: PBCK, PLRCK, DSCK, PSCK, DBCK, DSD1-DSD8, PDATA1-PDATA4.

(2) Pins 2, 3, 4, 36: MDI, MS, MC, RST.

(3) Pins 5-8: MDO, ZERO1, ZERO2, ZERO38.

(4) Analog performance specs are measured in the averaging mode using the System Two™ audio measurement system by Audio Precision™.

(5) These specs are measured under the condition that the OVR1, OVR0 in mode registers are set to (0,1). (The oversampling rate of the modulator is 64 f_S.) If the OVR1, OVR0 are (0,0) (32 f_S oversampling: default), the specs are the same as at f_S = 96 kHz.

ELECTRICAL CHARACTERISTICS(continued)

at $T_A = 25^\circ\text{C}$, $V_{DD} = 3.3\text{ V}$, $V_{CC} = 5\text{ V}$; in PCM mode, $f_S = 44.1\text{ kHz}$, system clock = $256 f_S$, 24-bit data; in DSD mode, $f_S = 2.8224\text{ MHz}$ (= $64 \times 44.1\text{ kHz}$), system clock = $256 \times 44.1\text{ kHz}$, 1-bit data (unless otherwise noted)

PARAMETER	TEST CONDITIONS	MIN	TYP	MAX	UNIT
DIGITAL INPUT/OUTPUT					
Logic family		TTL-compatible			
V_{IH}	Input logic level	2			Vdc
V_{IL}		0.8			
$I_{IH}^{(1)}$	Input logic current	$V_{IN} = V_{DD}$	10		μA
$I_{IL}^{(1)}$		$V_{IN} = 0\text{ V}$	-10		
$I_{IH}^{(2)}$		$V_{IN} = V_{DD}$	65	100	
$I_{IL}^{(2)}$		$V_{IN} = 0\text{ V}$	-10		
$V_{OH}^{(3)}$	Output logic level	$I_{OH} = -2\text{ mA}$	2.4		Vdc
$V_{OL}^{(3)}$		$I_{OL} = +2\text{ mA}$	1		
DYNAMIC PERFORMANCE⁽⁴⁾ (PCM MODE)					
THD+N at $V_{OUT} = 0\text{ dB}$	$f_S = 44.1\text{ kHz}$	0.0012%			
	$f_S = 96\text{ kHz}$	0.0015%			
	$f_S = 192\text{ kHz}^{(5)}$	0.002%			
THD+N at $V_{OUT} = -3\text{ dB}$	$f_S = 44.1\text{ kHz}$	0.0012%	0.0018%		
	$f_S = 96\text{ kHz}$	0.0015%			
	$f_S = 192\text{ kHz}^{(5)}$	0.002%			
Dynamic range	EIAJ, A-weighted, $f_S = 44.1\text{ kHz}$	104	108		dB
	EIAJ, A-weighted, $f_S = 96\text{ kHz}$	108			
	EIAJ, A-weighted, $f_S = 192\text{ kHz}^{(5)}$	107			
Signal-to-noise ratio	EIAJ, A-weighted, $f_S = 44.1\text{ kHz}$	104	108		dB
	EIAJ, A-weighted, $f_S = 96\text{ kHz}$	108			
	EIAJ, A-weighted, $f_S = 192\text{ kHz}^{(5)}$	107			
Channel separation	$f_S = 44.1\text{ kHz}$	101	104		dB
	$f_S = 96\text{ kHz}$	104			
	$f_S = 192\text{ kHz}^{(5)}$	103			
Level linearity error	$V_{OUT} = -90\text{ dB}$	± 0.5			dB
DYNAMIC PERFORMANCE⁽⁴⁾ DSD MODE (at $f_S = 64 \times 44.1\text{ kHz}$)					
THD+N at $V_{OUT} = 0\text{ dB}$		0.0012%			
Dynamic range	EIAJ, A-weighted	108			dB
Signal-to-noise ratio	EIAJ, A-weighted	108			dB
Channel separation		104			dB
Level linearity error	$V_{OUT} = -90\text{ dB}$	± 0.5			dB
DC ACCURACY					
Gain error		± 1	± 6		% FSR
Gain mismatch, channel-to-channel		± 1	± 3		% FSR
Bipolar zero error	$V_{OUT} = 0.5 V_{CC}$ at BPZ	± 30	± 60		mV
ANALOG OUTPUT					
Output voltage	Full scale (0 dB)	80% of V_{CC}			V_{pp}
Center voltage		50% of V_{CC}			Vdc
Load impedance	AC load	4			$k\Omega$

(1) Pins 50, 51, 34, 33, 37, 38–45, 46–49: PBCK, PLRCK, DSCK, PSCK, DBCK, DSD1–DSD8, PDATA1–PDATA4.

(2) Pins 2, 3, 4, 36: MDI, MS, MC, RST.

(3) Pins 5–8: MDO, ZERO1, ZERO2, ZERO38.

(4) Analog performance specs are measured in the averaging mode using the System Two™ audio measurement system by Audio Precision™.

(5) These specs are measured under the condition that the OVR1, OVR0 in mode registers are set to (0,1). (The oversampling rate of the modulator is $64 f_S$.) If the OVR1, OVR0 are (0,0) ($32 f_S$ oversampling: default), the specs are the same as at $f_S = 96\text{ kHz}$.

DSD1608

SLES040 – JUNE 2002

ELECTRICAL CHARACTERISTICS(continued)

 at $T_A = 25^\circ\text{C}$, $V_{DD} = 3.3\text{ V}$, $V_{CC} = 5\text{ V}$; in PCM mode, $f_S = 44.1\text{ kHz}$, system clock = $256 f_S$, 24-bit data; in DSD mode, $f_S = 2.8224\text{ MHz}$ (= $64 \times 44.1\text{ kHz}$), system clock = $256 \times 44.1\text{ kHz}$, 1-bit data (unless otherwise noted)

PARAMETER		TEST CONDITIONS	MIN	TYP	MAX	UNIT
DIGITAL FILTER PERFORMANCE						
8× INTERPOLATION FILTER (SHARP ROLL OFF FILTER)						
Pass band		$\pm 0.02\text{ dB}$		$0.454 f_S$		Hz
Pass band		-3 dB		$0.487 f_S$		Hz
Stop band			$0.546 f_S$			Hz
Pass-band ripple				± 0.02		dB
Stop-band attenuation		Stop band = $0.546 f_S$	-60			dB
Delay Time				$23/f_S$		s
8× INTERPOLATION FILTER (SLOW ROLL OFF FILTER)						
Pass band		-0.5 dB		$0.308 f_S$		Hz
Pass band		-3 dB		$0.432 f_S$		Hz
Stop band			$0.832 f_S$			Hz
Pass-band ripple		$0.308 f_S$		± 0.5		dB
Stop-band attenuation		$0.832 f_S$	-58			dB
Delay time				$23/f_S$		s
DE-EMPHASIS FILTER (PCM MODE ONLY)						
De-emphasis error		At $f_S = 32\text{ kHz}$, 44.1 kHz or 48 kHz		± 0.1		dB
DSD FILTER (FILTER-1)						
Pass band		At -3 dB		50		kHz
Stop-band attenuation		At 100 kHz		-18		dB
DSD FILTER (FILTER-2)						
Pass band		At -3 dB		70		kHz
Stop-band attenuation		At 100 kHz		-9.8		dB
DSD FILTER (FILTER-3)						
Pass band		At -3 dB		60		kHz
Stop-band attenuation		At 100 kHz		-17		dB
INTERNAL ANALOG FILTER PERFORMANCE						
Frequency response		At 20 kHz		-0.02		dB
		At 44 kHz		-0.1		
		At 50 kHz		-0.12		
		At 100 kHz		-0.5		
POWER SUPPLY REQUIREMENTS						
V_{DD}	Voltage range		3	3.3	3.6	Vdc
V_{CC}			4.5	5.0	5.5	
I_{DD}	Supply current	$f_S = 44.1\text{ kHz}$		28	40	mA
		$f_S = 192\text{ kHz}$		74		
		DSD mode		45		
I_{CC}		$f_S = 44.1\text{ kHz}$		36	50	
		$f_S = 192\text{ kHz}$		38		
Power dissipation		$f_S = 44.1\text{ kHz}$		270	380	mW
		$f_S = 192\text{ kHz}$		430		

(1) Pins 50, 51, 34, 33, 37, 38–45, 46–49: PBCK, PLRCK, DSCK, PSCK, DBCK, DSD1–DSD8, PDATA1–PDATA4.

(2) Pins 2, 3, 4, 36: MDI, MS, MC, RST.

(3) Pins 5–8: MDO, ZERO1, ZERO2, ZERO38.

(4) Analog performance specs are measured in the averaging mode using the System Two™ audio measurement system by Audio Precision™.

 (5) These specs are measured under the condition that the OVR1, OVR0 in mode registers are set to (0,1). (The oversampling rate of the modulator is $64 f_S$.) If the OVR1, OVR0 are (0,0) ($32 f_S$ oversampling: default), the specs are the same as at $f_S = 96\text{ kHz}$.

ELECTRICAL CHARACTERISTICS(continued)

at $T_A = 25^\circ\text{C}$, $V_{DD} = 3.3\text{ V}$, $V_{CC} = 5\text{ V}$; in PCM mode, $f_S = 44.1\text{ kHz}$, system clock = $256 f_S$, 24-bit data; in DSD mode, $f_S = 2.8224\text{ MHz}$ ($= 64 \times 44.1\text{ kHz}$), system clock = $256 \times 44.1\text{ kHz}$, 1-bit data (unless otherwise noted)

PARAMETER	TEST CONDITIONS	MIN	TYP	MAX	UNIT
TEMPERATURE RANGE					
Operating temperature		-25		85	$^\circ\text{C}$
θ_{JA} Thermal resistance	52 TQFP		70		$^\circ\text{C/W}$

- (1) Pins 50, 51, 34, 33, 37, 38–45, 46–49: PBCK, PLRCK, DSCK, PSCK, DBCK, DSD1–DSD8, PDATA1–PDATA4.
- (2) Pins 2, 3, 4, 36: MDI, MS, MC, RST.
- (3) Pins 5–8: MDO, ZERO1, ZERO2, ZERO38.
- (4) Analog performance specs are measured in the averaging mode using the System Two™ audio measurement system by Audio Precision™.
- (5) These specs are measured under the condition that the OVR1, OVR0 in mode registers are set to (0,1). (The oversampling rate of the modulator is $64 f_S$.) If the OVR1, OVR0 are (0,0) ($32 f_S$ oversampling: default), the specs are the same as at $f_S = 96\text{ kHz}$.

PIN ASSIGNMENTS

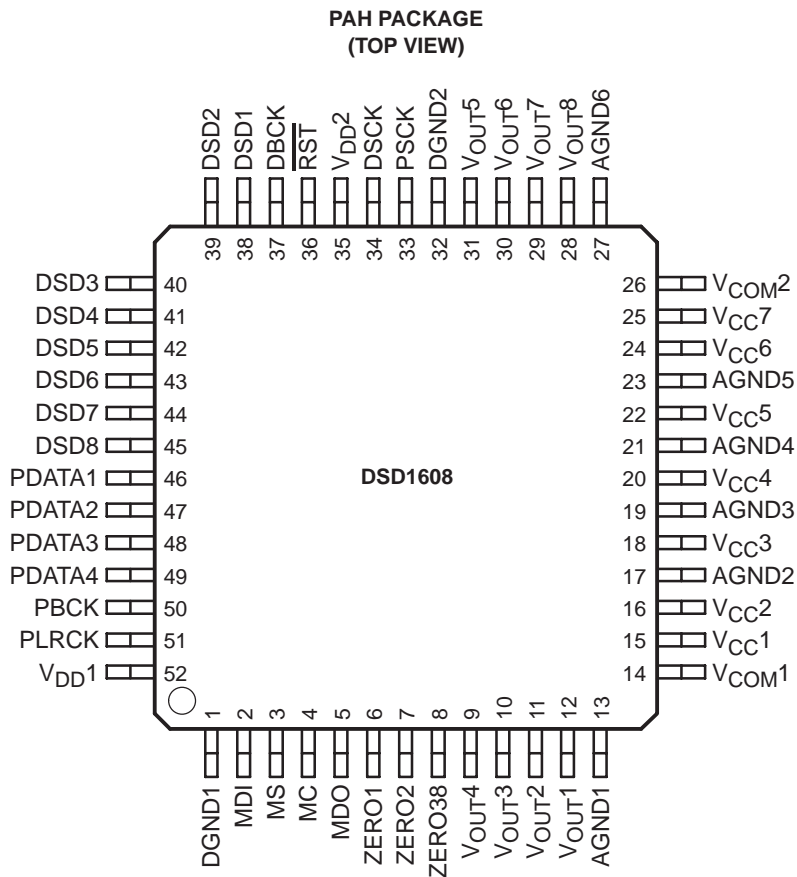

Audio Precision and System Two are trademarks of Audio Precision, Inc.
Other trademarks are the property of their respective owners.

Terminal Functions

TERMINAL NAME	NO.	I/O	DESCRIPTION
AGND1	13	—	Analog ground
AGND2	17	—	Analog ground
AGND3	19	—	Analog ground
AGND4	21	—	Analog ground
AGND5	23	—	Analog ground
AGND6	27	—	Analog ground
DBCK	37	I	DSD audio data bit clock input (DSD) ⁽³⁾
DGND1	1	—	Digital ground
DGND2	32	—	Digital ground
DSCK	34	I	System clock input (DSD). Input frequency is 256, 384, 512 or 768 f _S ⁽³⁾
DSD1	38	I	DSD audio data input for V _{OUT1} (DSD) ⁽³⁾
DSD2	39	I	DSD audio data input for V _{OUT2} (DSD) ⁽³⁾
DSD3	40	I	DSD audio data input for V _{OUT3} (DSD) ⁽³⁾
DSD4	41	I	DSD audio data input for V _{OUT4} (DSD) ⁽³⁾
DSD5	42	I	DSD audio data input for V _{OUT5} (DSD) ⁽³⁾
DSD6	43	I	DSD audio data input for V _{OUT6} (DSD) ⁽³⁾
DSD7	44	I	DSD audio data input for V _{OUT7} (DSD) ⁽³⁾
DSD8	45	I	DSD audio data input for V _{OUT8} (DSD) ⁽³⁾
MC	4	I	Mode control clock input ⁽¹⁾
MDI	2	I	Mode control data input ⁽¹⁾
MDO	5	O	Mode control read back data output ⁽⁴⁾
MS	3	I	Chip select for mode control ⁽¹⁾
PBCK	50	I	Audio data bit clock input (PCM) ⁽³⁾
PDATA1	46	I	Serial audio data input for V _{OUT1} and V _{OUT2} (PCM) ⁽³⁾
PDATA2	47	I	Serial audio data input for V _{OUT3} and V _{OUT4} (PCM) ⁽³⁾
PDATA3	48	I	Serial audio data input for V _{OUT5} and V _{OUT6} (PCM) ⁽³⁾
PDATA4	49	I	Serial audio data input for V _{OUT7} and V _{OUT8} (PCM) ⁽³⁾
PLRCK	51	I	Audio data L/R clock input (PCM) ⁽³⁾
PSCK	33	I	System clock input (PCM). Input frequency is 128, 192, 256, 384, 512 or 768 f _S ⁽³⁾
RST	36	I	System reset, active LOW ⁽²⁾
VCC1	15	—	Analog power supply, 5 V
VCC2	16	—	Analog power supply, 5 V
VCC3	18	—	Analog power supply, 5 V
VCC4	20	—	Analog power supply, 5 V
VCC5	22	—	Analog power supply, 5 V
VCC6	24	—	Analog power supply, 5 V
VCC7	25	—	Analog power supply, 5 V
VCOM1	14	O	Common voltage output 1. This pin should be bypassed with a 10-μF capacitor to AGND.

(1) Schmitt-trigger input with internal pulldown.

(2) Schmitt-trigger input with internal pulldown, 5-V tolerant.

(3) Schmitt-trigger input, 5-V tolerant.

(4) 3-state output.

Terminal Functions (continued)

TERMINAL NAME	NO.	I/O	DESCRIPTION
V _{COM2}	26	O	Common voltage output 2. This pin should be bypassed with a 10- μ F capacitor to AGND.
V _{DD1}	52	—	Digital power supply, 3.3 V
V _{DD2}	35	—	Digital power supply, 3.3 V
V _{OUT1}	12	O	Voltage output for audio signal corresponding to L-channel on PDATA1 or DSD1
V _{OUT2}	11	O	Voltage output for audio signal corresponding to R-channel on PDATA1 or DSD2
V _{OUT3}	10	O	Voltage output for audio signal corresponding to L-channel on PDATA2 or DSD3
V _{OUT4}	9	O	Voltage output for audio signal corresponding to R-channel on PDATA2 or DSD4
V _{OUT5}	31	O	Voltage output for audio signal corresponding to L-channel on PDATA3 or DSD5
V _{OUT6}	30	O	Voltage output for audio signal corresponding to R-channel on PDATA3 or DSD6
V _{OUT7}	29	O	Voltage output for audio signal corresponding to L-channel on PDATA4 or DSD7
V _{OUT8}	28	O	Voltage output for audio signal corresponding to R-channel on PDATA4 or DSD8
ZERO1	6	O	Zero data flag for V _{OUT1}
ZERO2	7	O	Zero data flag for V _{OUT2}
ZERO38	8	O	Zero data flag for V _{OUT3} –V _{OUT8}

- (1) Schmitt-trigger input with internal pulldown.
(2) Schmitt-trigger input with internal pulldown, 5-V tolerant.
(3) Schmitt-trigger input, 5-V tolerant.
(4) 3-state output.

DSD1608

SLES040 – JUNE 2002

BLOCK DIAGRAM

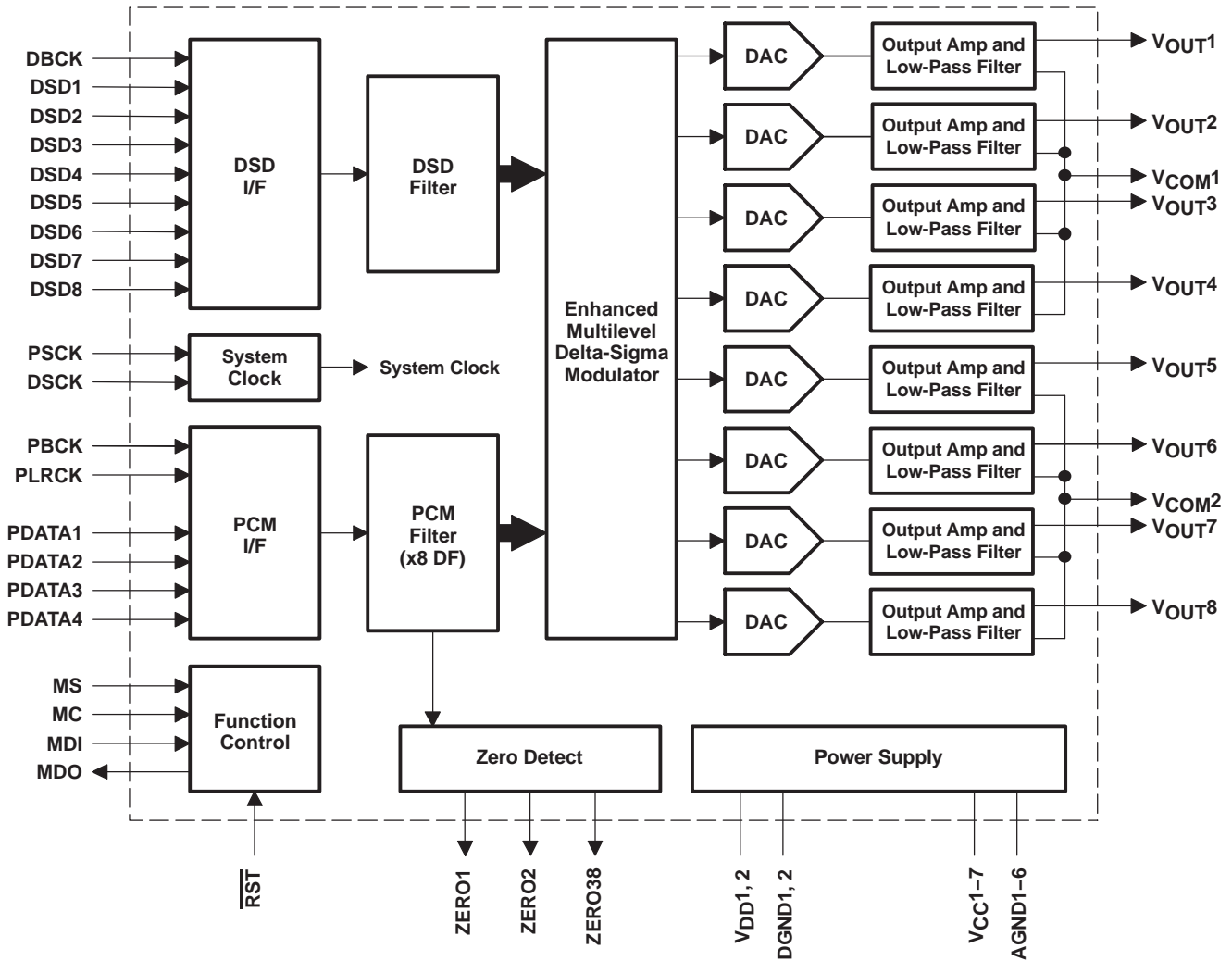

TYPICAL PERFORMANCE CURVES

DIGITAL FILTER—PCM MODE

8× Interpolation Filter (De-Emphasis Off)

**AMPLITUDE
VS
FREQUENCY**

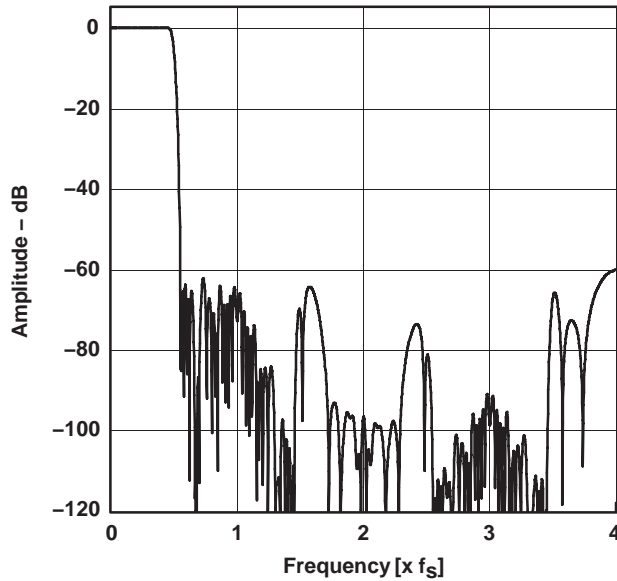

Figure 1. Frequency Response (Sharp Rolloff)

**AMPLITUDE
VS
FREQUENCY**

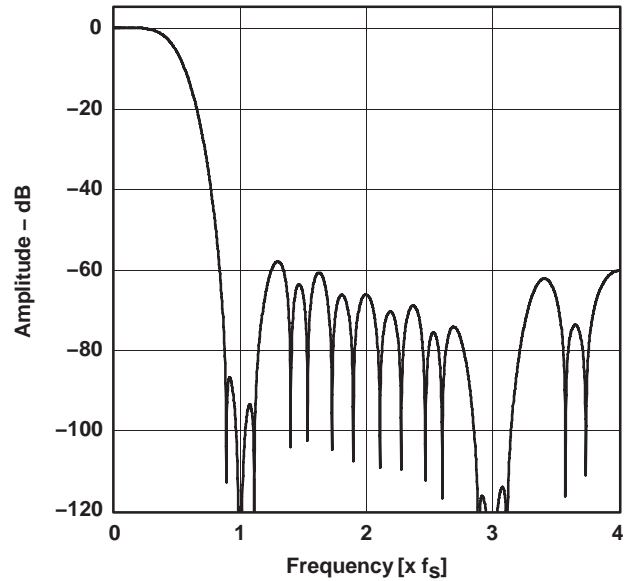

Figure 2. Frequency Response (Slow Rolloff)

**AMPLITUDE
VS
FREQUENCY**

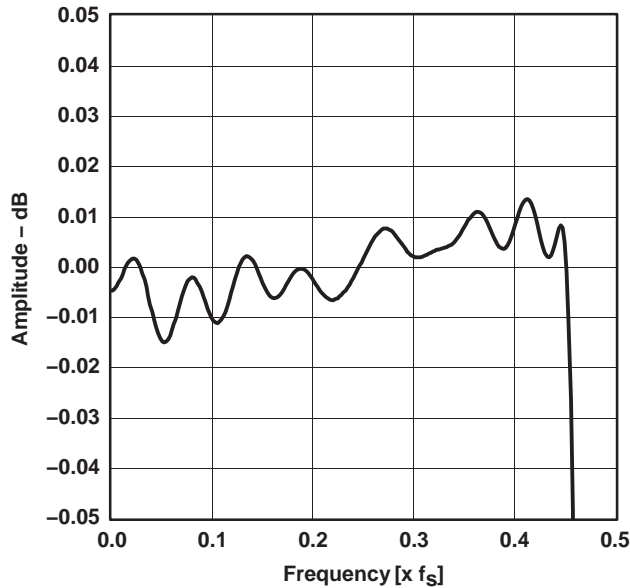

Figure 3. Pass-Band Ripple (Sharp Rolloff)

**AMPLITUDE
VS
FREQUENCY**

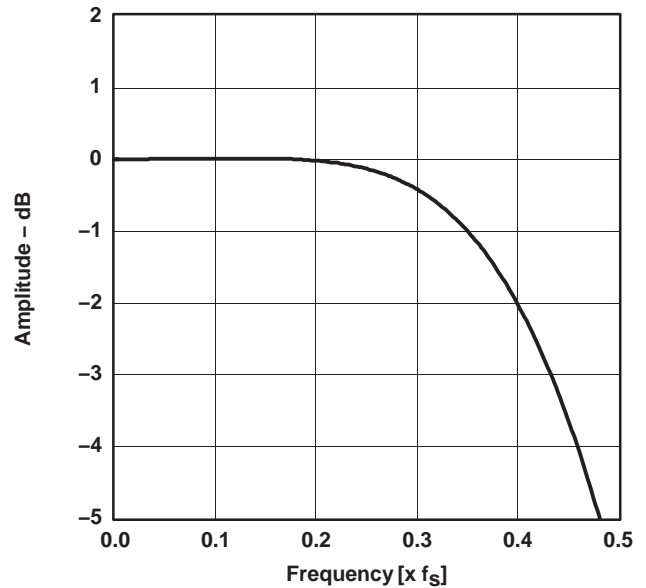

Figure 4. Frequency Response (Slow Rolloff)

DSD1608

SLES040 – JUNE 2002

De-Emphasis Curves

DE-EMPHASIS LEVEL
VS
FREQUENCY

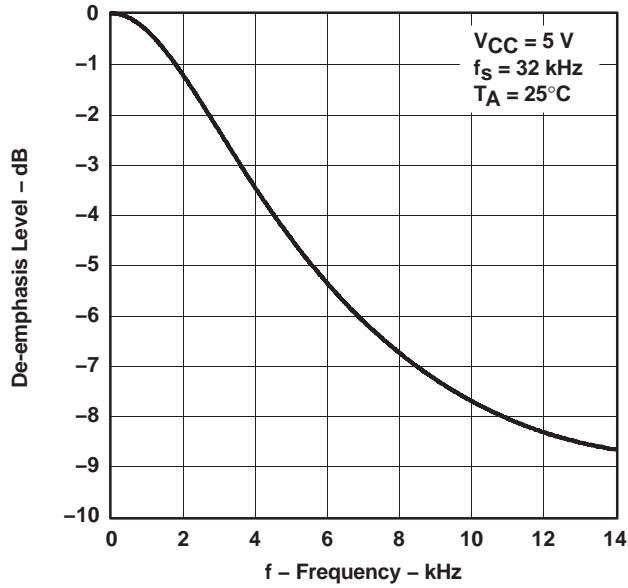

Figure 5

DE-EMPHASIS ERROR
VS
FREQUENCY

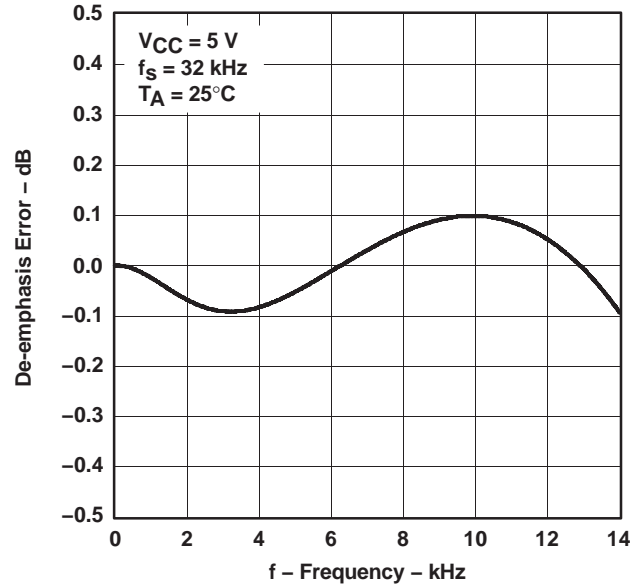

Figure 6

DE-EMPHASIS LEVEL
VS
FREQUENCY

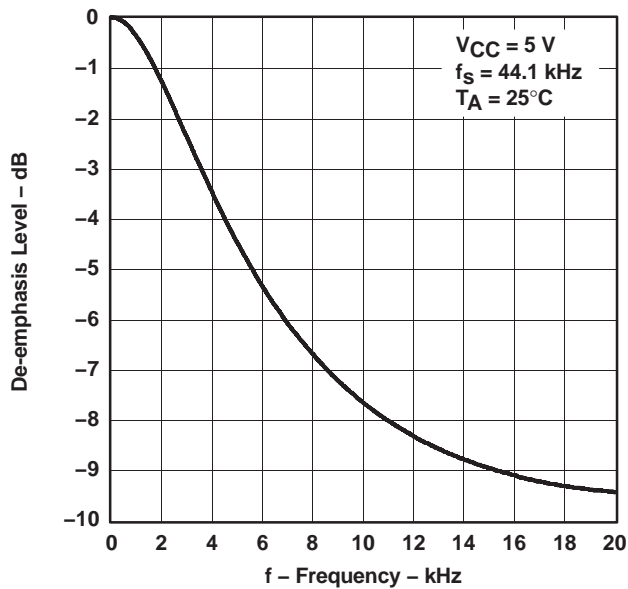

Figure 7

DE-EMPHASIS ERROR
VS
FREQUENCY

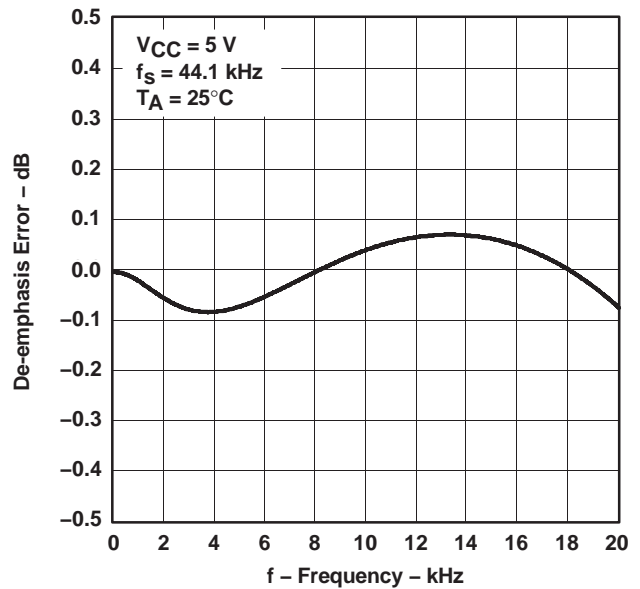

Figure 8

De-Emphasis Curves (Continued)

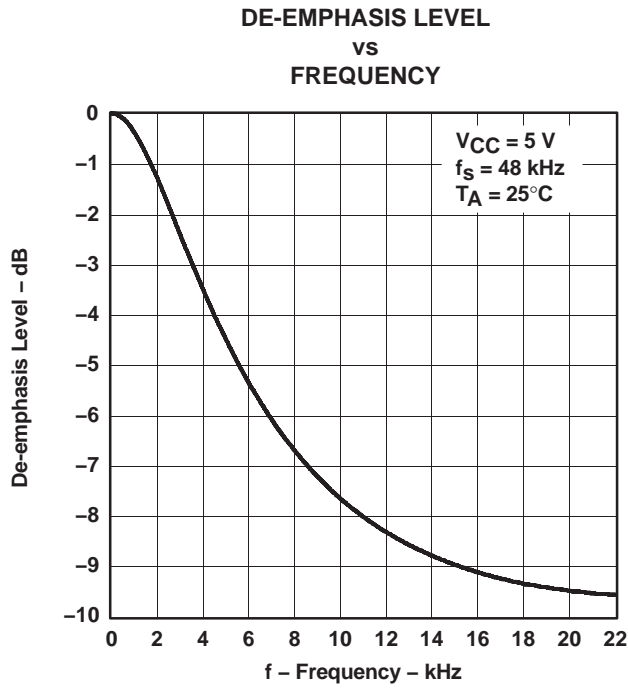

Figure 9

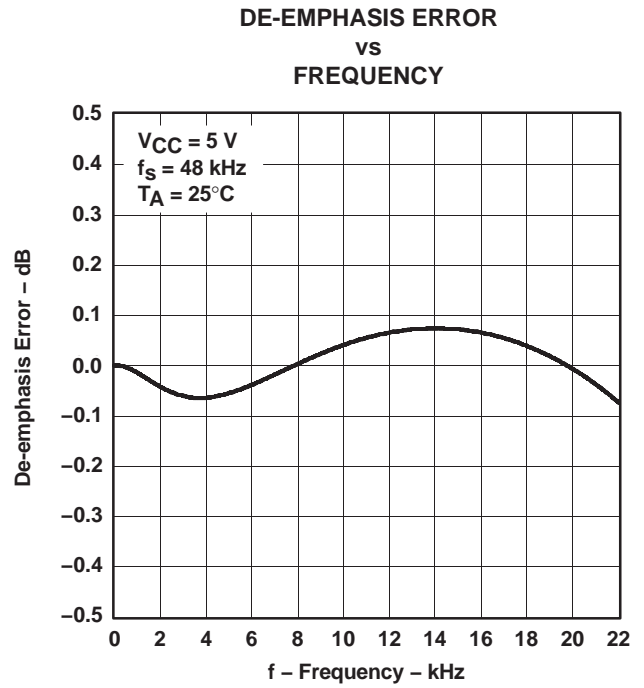

Figure 10

DSD1608

SLES040 – JUNE 2002

ANALOG DYNAMIC PERFORMANCE Supply Voltage Characteristics

TOTAL HARMONIC DISTORTION + NOISE (-3 dB)
VS
SUPPLY VOLTAGE

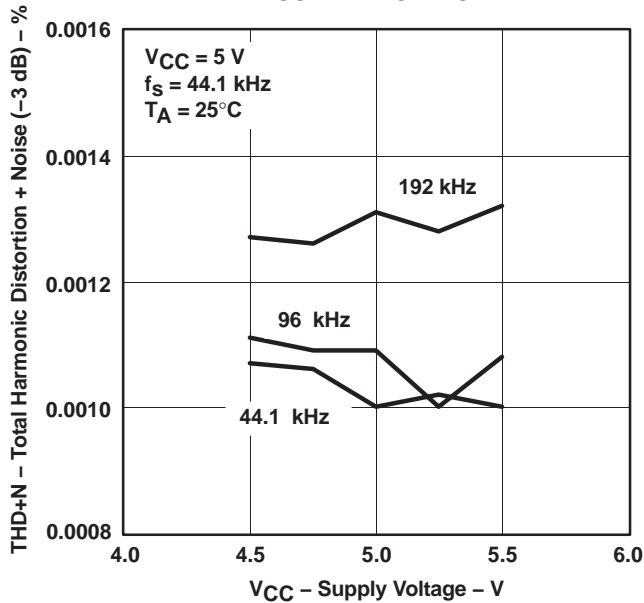

Figure 11

DYNAMIC RANGE
VS
SUPPLY VOLTAGE

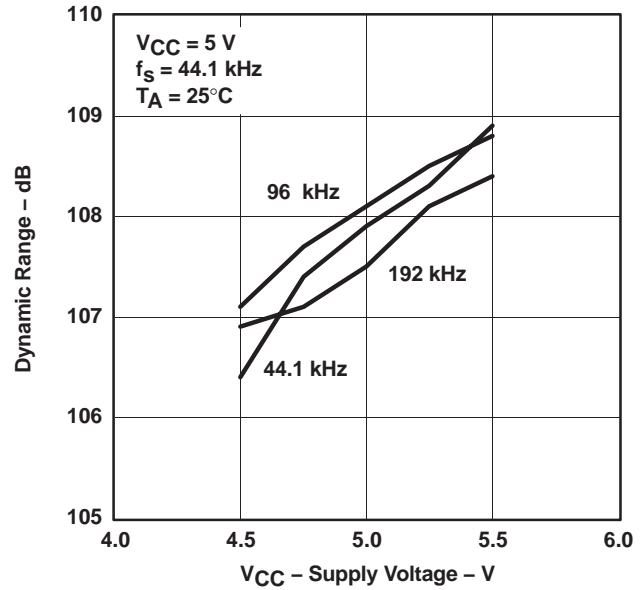

Figure 12

SNR
VS
SUPPLY VOLTAGE

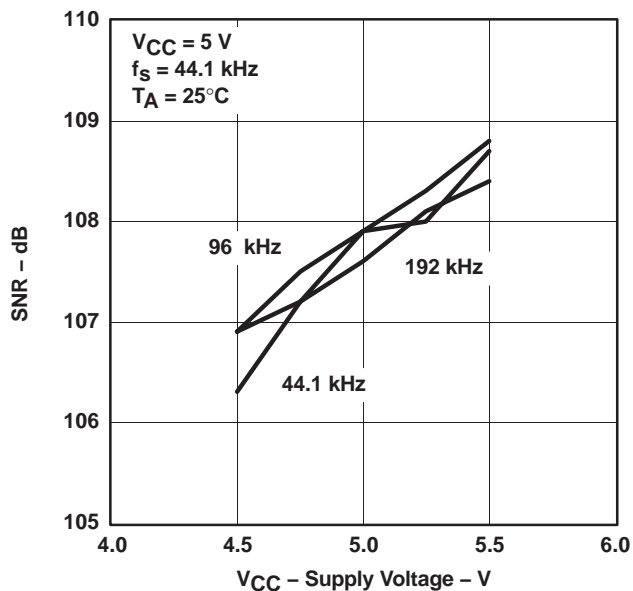

Figure 13

CHANNEL SEPARATION
VS
SUPPLY VOLTAGE

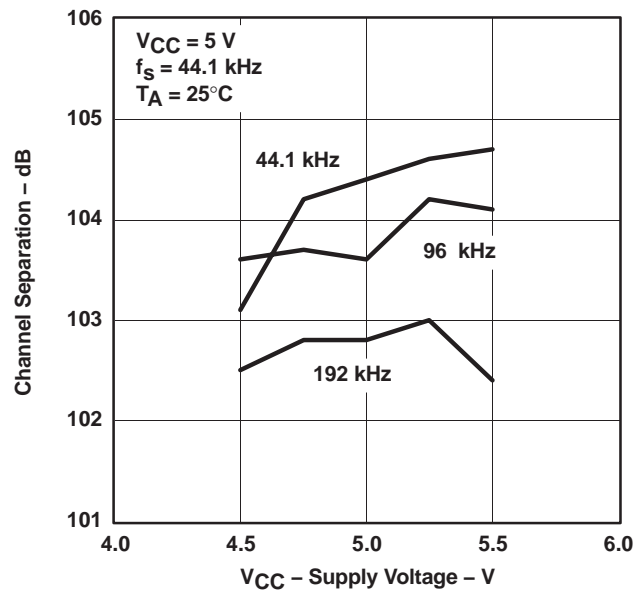
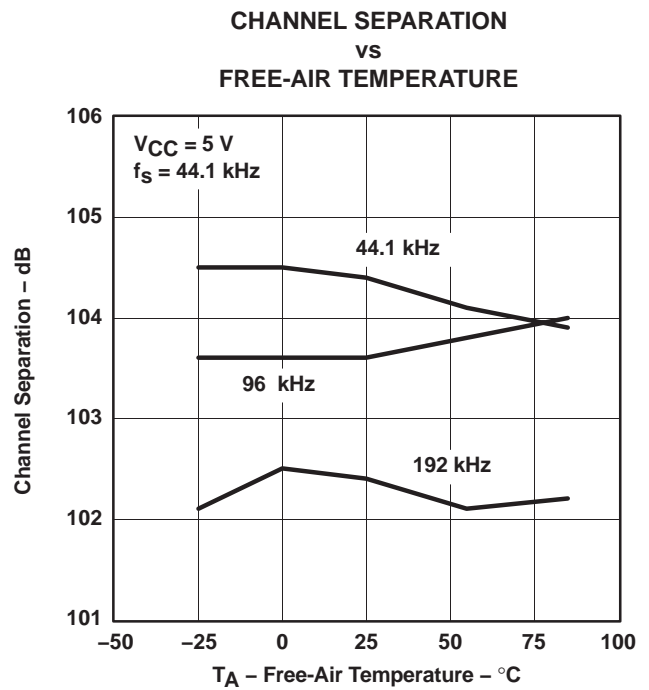
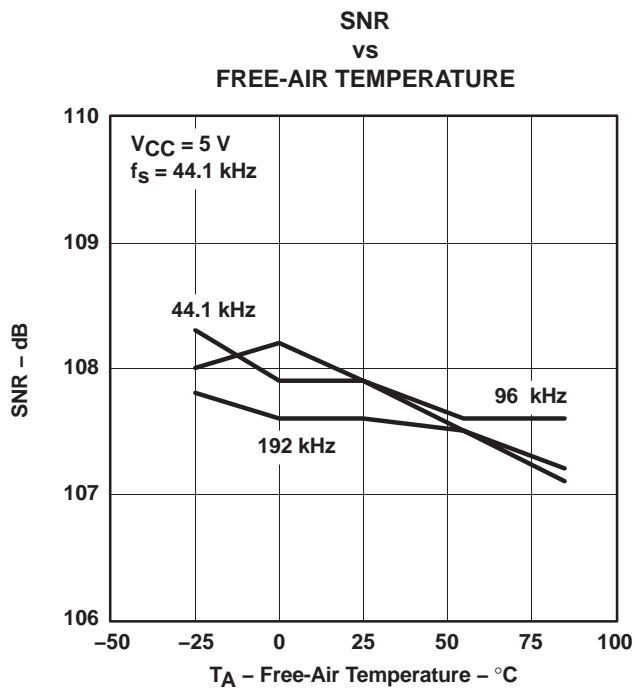
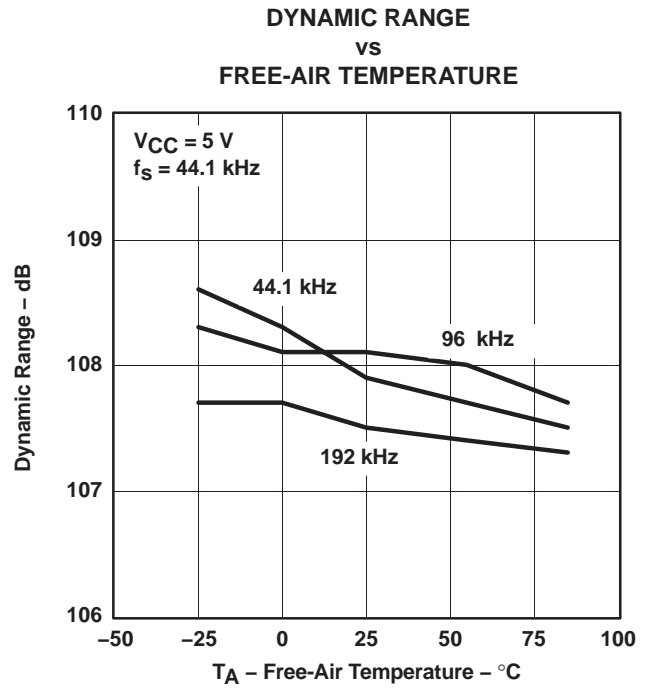
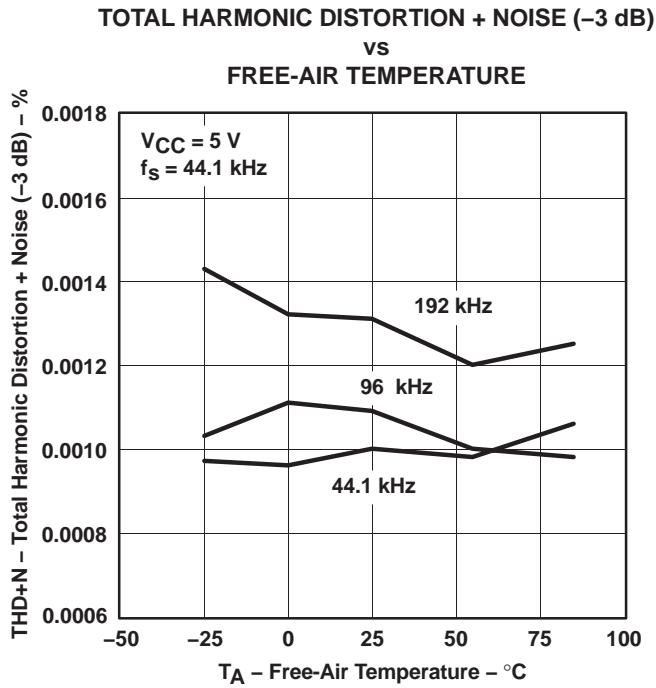

Figure 14

All specifications at $T_A = +25^\circ\text{C}$, $V_{CC} = 5.0\text{ V}$, $V_{DD} = 3.3\text{ V}$, $f_s = 44.1\text{ kHz}$, system clock = $384 f_s$ and 24-bit data, unless otherwise noted

Temperature Characteristics

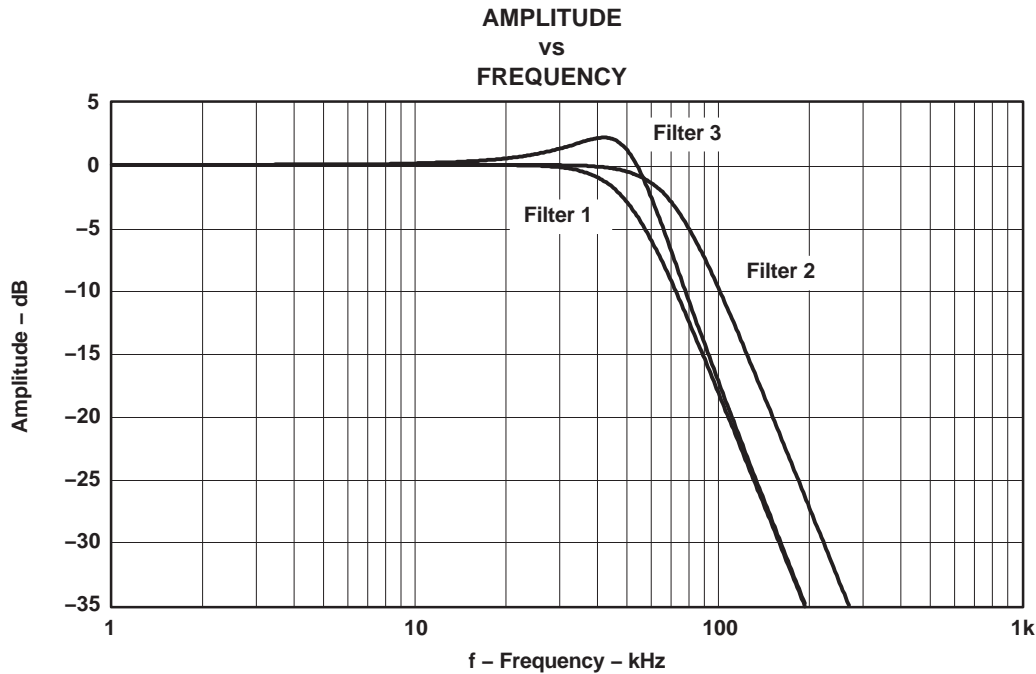

All specifications at $T_A = +25^\circ\text{C}$, $V_{CC} = 5.0\text{ V}$, $V_{DD} = 3.3\text{ V}$, $f_S = 44.1\text{ kHz}$, system clock = $384 f_S$ and 24-bit data, unless otherwise noted

DIGITAL FILTER—DSD MODE

Figure 19
SYSTEM CLOCK AND RESET FUNCTIONS
System clock input

The DSD1608 requires a system clock for operating the digital interpolation filter, digital DSD filter and multilevel delta-sigma modulator. The system clock is applied to PSCK (pin 33) in the PCM mode and to DSCK (pin 34) in the DSD mode. When CKCE (control register 10, B3) is not set to 1, the system clock is applied to PSCK in the DSD mode. The DSD1608 has a system clock detection circuit. Table 1 shows examples of system clock frequencies for common audio sampling rates.

Figure 20 shows the timing requirements for the system clock input. For optimal performance, it is important to use a clock source with low phase jitter and noise. Texas Instruments' PLL1700 multiclock generator is an excellent choice for providing the DSD1608 system.

In the PCM mode, the oversampling rate of digital filter is $4\times$ when a $128-f_S$ or $192-f_S$ system clock is applied to the DSD1608. When a $256-f_S$, $384-f_S$, $512-f_S$, or $768-f_S$ system clock is applied, the oversampling rate is $8\times$.

Table 1. System Clock Rates for Common Audio Sampling Frequencies

MODE	SAMPLING FREQUENCY	SYSTEM CLOCK FREQUENCY (f_{SCLK}) (MHz)					
		$128 f_S$	$192 f_S$	$256 f_S$	$384 f_S$	$512 f_S$	$768 f_S$
PCM	16kHz	2.0480	3.0720	4.0960	6.1440	8.1920	12.2880
	32kHz	4.0960	6.1440	8.1920	12.2880	16.3840	24.5760
	44.1kHz	5.6488	8.4672	11.2896	16.9344	22.5792	33.8688
	48kHz	6.1440	9.2160	12.2880	18.4320	24.5760	36.8640
	88.2kHz	11.2896	16.9344	22.5792	33.8688	45.1584	67.7376
	96kHz	12.2880	18.4320	24.5760	36.8640	49.1520	73.7280
	192kHz	24.5760	36.8640	See Note	See Note	See Note	See Note
DSD	$64\times 44.1\text{kHz}$	—	—	11.2896	16.9344	22.5792	33.8688

NOTE: This system clock is not supported for the given sampling frequency.

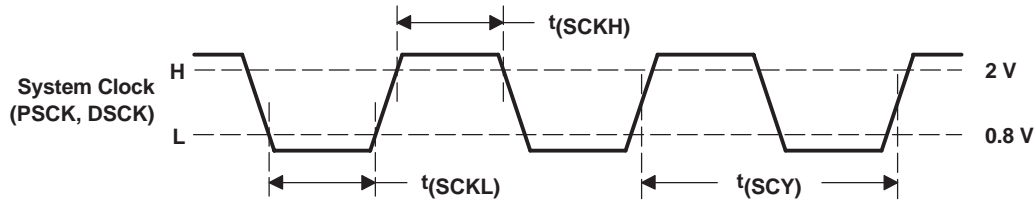

SYMBOL	PARAMETERS	MIN	MAX	UNIT
$t(SCY)$	System clock pulse cycle time	13		ns
$t(SCKH)$	System clock pulse duration high	$0.4 t_{SCY}$		ns
$t(SCKL)$	System clock pulse duration low	$0.4 t_{SCY}$		ns

Figure 20. System Clock Input Timing

Power-On and External Reset Functions

The DSD1608 includes a power-on reset function. Figure 21 shows the operation of this function. With $V_{DD} > 2 V$, the power-on reset function is enabled. The initialization sequence requires 1024 system clocks from the time $V_{DD} > 2 V$. After the initialization period, the DSD1608 is set to its reset default state, as described in the *mode control register* section of this data sheet. The DSD1608 also includes an external reset capability using the \overline{RST} input (pin 36). This allows an external controller or master reset circuit to force the DSD1608 to initialize to its reset state. Figure 22 shows the external reset operation and timing. The \overline{RST} pin is set to logic 0 for a minimum of 20 ns. When the \overline{RST} pin is set to a logic 0 state, the DSD1608 is initialized. The \overline{RST} pin is then set to a logic 1 state, thus starting the initialization sequence, which requires 1024 system clock periods.

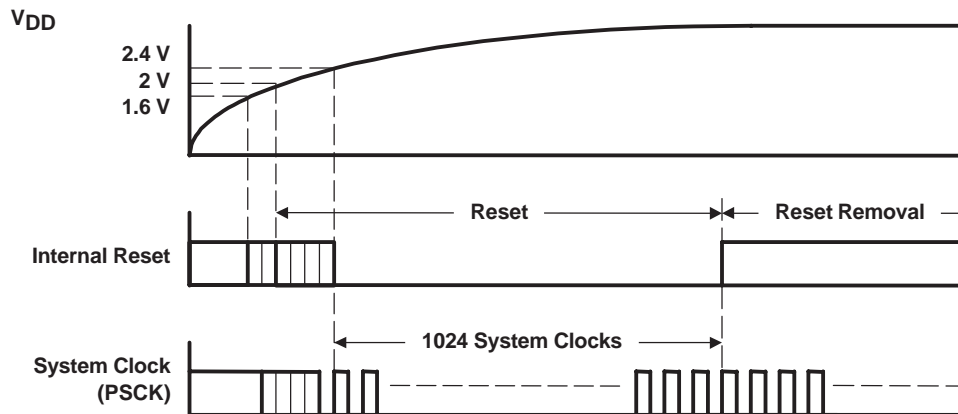
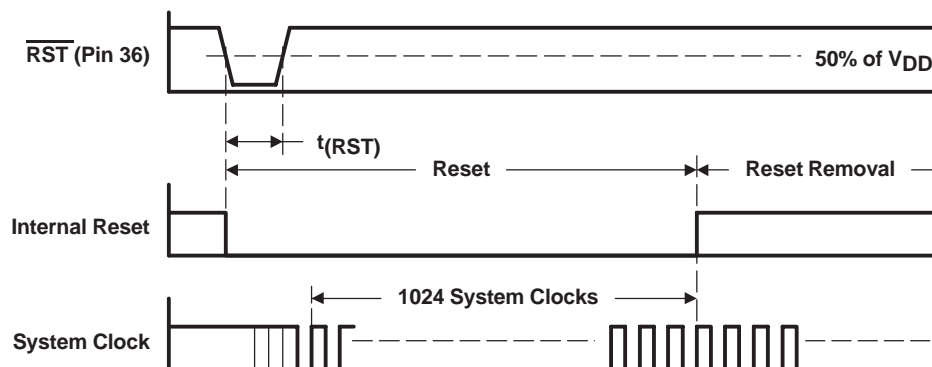

Figure 21. Power-On Reset Timing



SYMBOL	PARAMETERS	MIN	MAX	UNIT
$t(RST)$	Reset pulse duration low	20		ns

Figure 22. External Reset Timing

DSD1608

SLES040 – JUNE 2002

Audio Serial Interface

The DSD1608 has two audio serial interface ports: PCM audio interface port and DSD audio interface port.

In the PCM mode, the audio interface is a 3-wire serial port. It includes PLRCK (pin 51), PBCK (pin 50), and PDATA1–PDATA4 (pins 46–49). PBCK is the serial audio bit clock, and it is used to clock the serial data present on PDATA1–4 into the audio interface serial shift register. Serial data is clocked into the DSD1608 on the rising edge of PBCK. PLRCK is the serial audio left/right word clock. It is used to latch serial data into the serial audio interface internal registers.

The DSD1608 requires the synchronization of PLRCK to the system clock, but does not require a specific phase relation between PLRCK and system clock.

If the relationship between PLRCK and system clock changes more than ± 6 PBCK, internal operation is initialized within $1/f_S$ and analog outputs are forced to $0.5 V_{CC}$ until re-synchronization between PLRCK and the system clock is completed.

In the DSD mode, the audio interface is a 2-wire serial port. DBCK (pin 37) is the serial audio bit clock, and it is used to clock the individual direct stream digital (DSD) audio data on DSD1–DSD8 (pins 38–45). DSD data is clocked into the DSD1608 on the rising edge of DBCK. DBCK must be synchronous with the system clock, but does not require a specific phase relation to the system clock. DBCK is operated at the sampling frequency f_S ; the f_S of DSD is 64×44.1 kHz, nominal.

Audio Data Formats and Timing

In the PCM mode, the DSD1608 supports industry-standard audio data formats, including standard, I^2S , and left-justified. The data formats are shown in Figure 23. Data formats are selected using the format bits, FMT[2:0], in control register 10. The default data format is 24-bit standard format. All formats require binary 2s complement, MSB-first audio data. Figure 24 shows a detailed timing diagram for the serial audio interface.

In the DSD mode, the DSD1608 supports a DSD audio data format. The data formats are shown in Figure 25. Figure 26 shows a detailed timing diagram for the DSD audio data interface.

Serial Control Interface

The serial control interface is a 4-wire serial port which operates completely asynchronously from the serial audio interface and the system clock. The serial control interface is used to access the on-chip mode registers. The control interface includes MDI (pin 2), MDO (pin 5), MC (pin 4), and MS (pin 3). MDI is the serial data input, used to program the mode registers. MDO is the serial data output, used to read back the values of the mode registers. MC is the serial bit clock, used to shift data into the control port, and MS is the chip select for the control port.

(1) STD Format: L-Channel = H, R-Channel = L

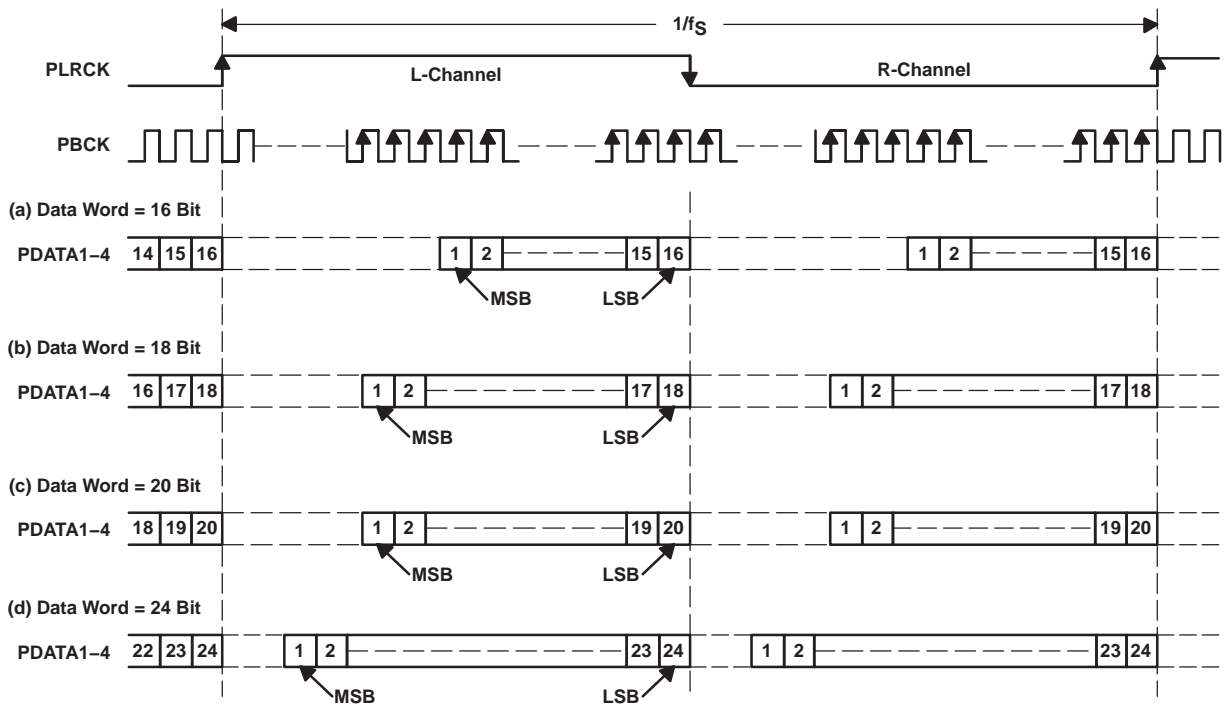

(2) IIS Format: L-Channel = L, R-Channel = H

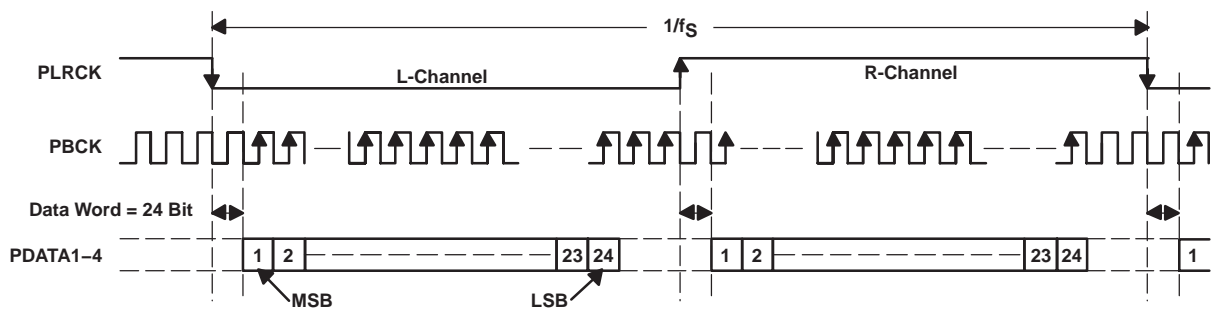

(3) Left Justified Format: L-Channel = H, R-Channel = L

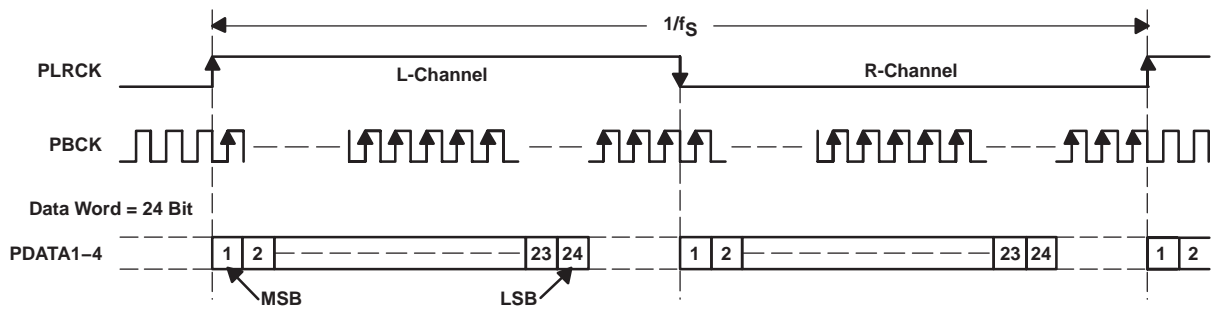
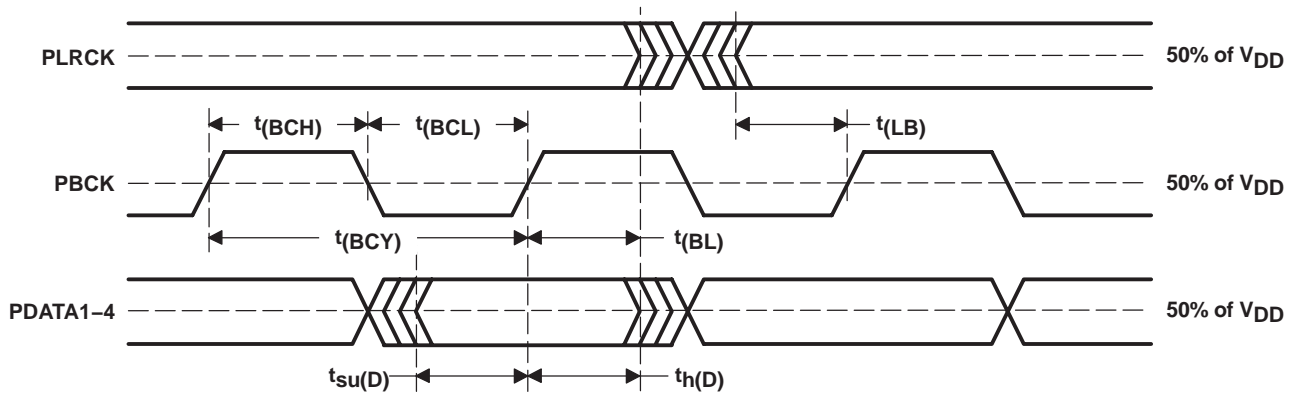

Figure 23. PCM Data Format

DSD1608

SLES040 – JUNE 2002



SYMBOL	PARAMETERS	MIN	MAX	UNIT
$t_{(BCY)}$	PBCK pulse cycle time	70		ns
$t_{(BCH)}$	PBCK high-level time	30		ns
$t_{(BCL)}$	PBCK low-level time	30		ns
$t_{(BL)}$	PBCK rising edge to PLRCK edge	10		ns
$t_{(LB)}$	PLRCK edge to PBCK rising edge	10		ns
$t_{su(D)}$	PDATA1-4 setup time	10		ns
$t_{h(D)}$	PDATA1-4 hold time	10		ns

Figure 24. Timing for PCM Audio Interface

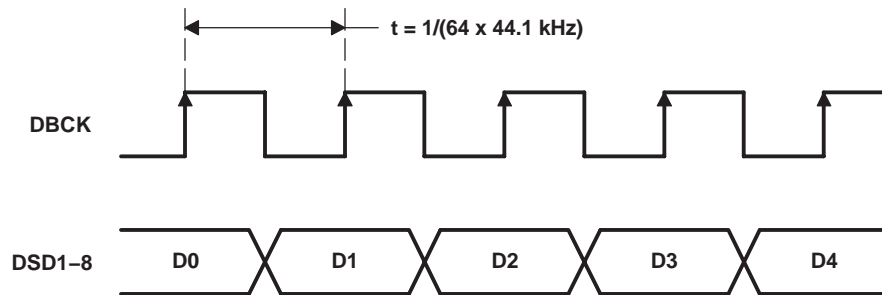
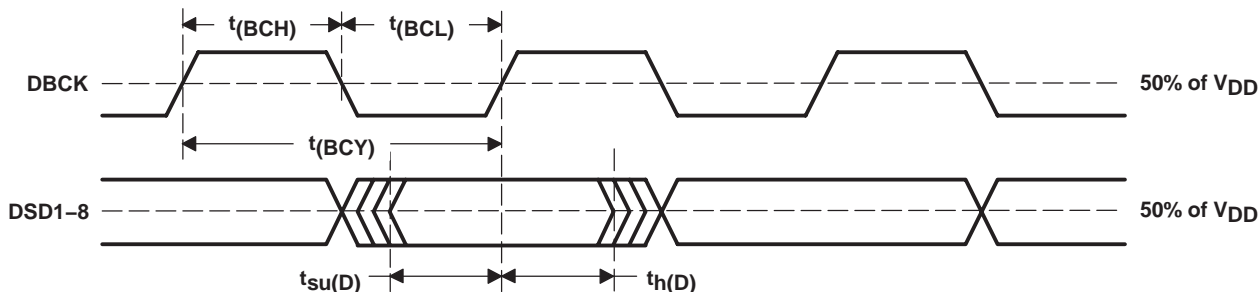

Figure 25. Normal Data Output Form From DSD Decoder



SYMBOL	PARAMETERS	MIN	MAX	UNIT
$t_{(BCY)}$	DBCK pulse cycle time	350 ⁽¹⁾		ns
$t_{(BCH)}$	DBCK high-level time	30		ns
$t_{(BCL)}$	DBCK low-level time	30		ns
$t_{su(D)}$	DSD1-8 setup time	10		ns
$t_{h(D)}$	DSD1-8 hold time	10		ns

(1) 2.8224 MHz = 64 × 44.1 kHz; this value is specified as a sampling rate of DSD.

Figure 26. Timing for DSD Audio Interface

Register Read/Write Operation

All read/write operations for the serial control port use 16-bit data words. Figure 27 shows the control data word format. The most significant bit is the read/write (R/W) bit. For write operations, the R/W bit must be set to 0. For read operations, the R/W bit must be set to 1. There are seven bits, labeled $IDX[6:0]$, that set the register index (or address) for the read or write operations. The least significant eight bits, $D[7:0]$, contain the data to be written to the register specified by $IDX[6:0]$ or to be read from the register specified by $IDX[6:0]$.

Figure 28 shows the functional timing diagram for writing or reading the serial control port. MS is held at a logic 1 state until a register needs to be written or read. To start the register write or read cycle, MS is set to logic 0. Sixteen clocks are then provided on MC, corresponding to the 16 bits of the control data word on MDI and read back data on MDO. After the eighth clock cycle has completed, the data from indexed mode control register appears on MDO in read operation. After the sixteenth clock cycle has completed, the data is latched into the indexed mode control register in write operations. To write or read subsequent data, MS must be set to 1 once.

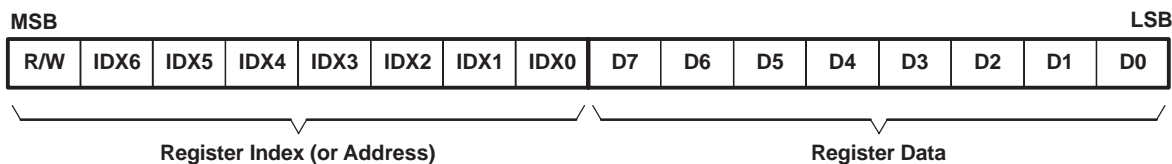

Figure 27. Control Data Word Format for MDI

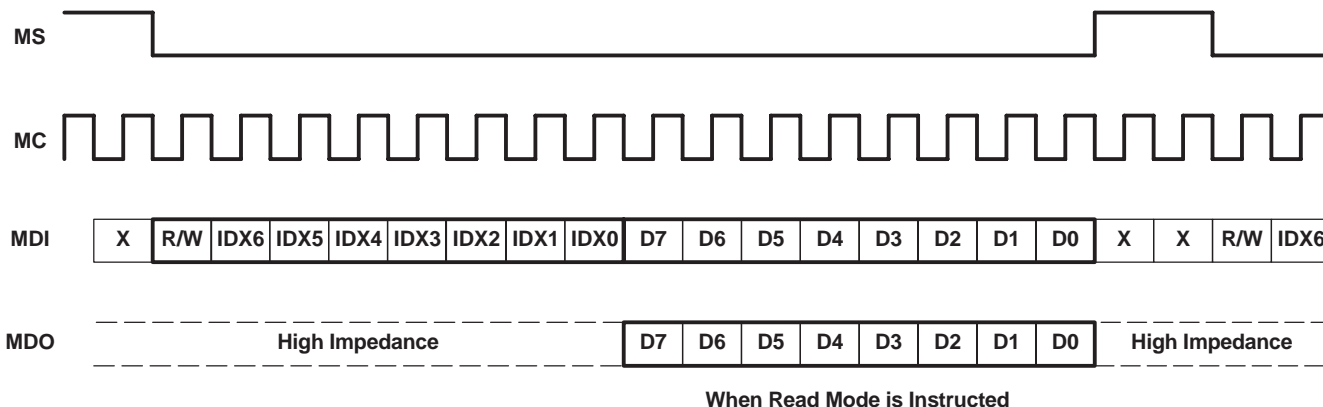
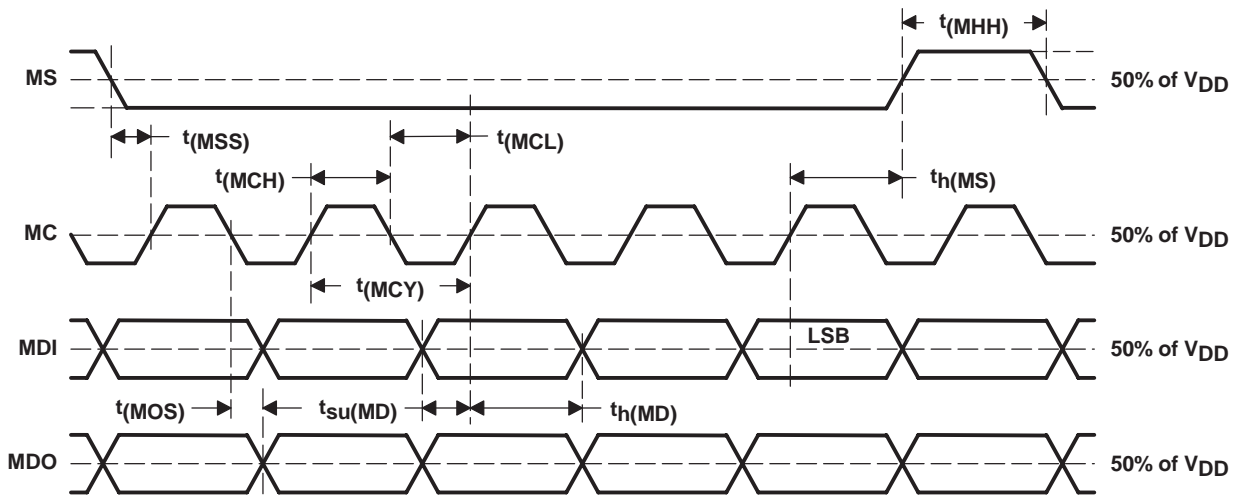

Figure 28. Serial Control Format

Control Interface Timing Requirements

Figure 29 shows a detailed timing diagram for the serial control interface. These timing parameters are critical for proper control port operation.



SYMBOL	PARAMETERS	MIN	MAX	UNIT
$t(\text{MCY})$	MC pulse cycle time	100		ns
$t(\text{MCL})$	MC low level time	40		ns
$t(\text{MCH})$	MC high level time	40		ns
$t(\text{MHH})$	MS high level time	80		ns
$t(\text{MSS})$	MS falling edge to MC rise edge	15		ns
$t_h(\text{MS})$	MS hold time ⁽¹⁾	15		ns
$t_h(\text{MD})$	MDI hold time	15		ns
$t_{su}(\text{MD})$	MDI setup time	15		ns
$t(\text{MOS})$	MC falling edge to MDO stable		30	ns

⁽¹⁾ MC rising edge for LSB-to-MS rising edge.

Figure 29. Control Interface Timing

MODE CONTROL REGISTERS

User-Programmable Mode Controls

The DSD1608 includes a number of user programmable functions which are accessed via control registers. The registers are programmed using the serial control interface which was previously discussed in this data sheet. Table 2 lists the available mode control functions, along with their reset default conditions and associated register index.

Register Map

The mode control register map is shown in Table 3. Each register includes an index (or address) indicated by the $\text{IDX}[6:0]$ bits $\text{B}[14:8]$.

Table 2. User-Programmable Mode Controls

FUNCTION	RESET DEFAULT	REGISTER	BIT(S)	PCM	DSD
Digital attenuation control, 0 dB to $-\infty$ in 0.5 dB steps	0dB, no attenuation	0–7	AT1[7:0] to AT8[7:0]	√	√
Soft mute control	Mute disabled	8	MUT[8:1]	√	√
DAC operation control	DAC1 to DAC8 enabled	9	DAC[8:1]	√	√
Audio data format control	24-bit standard format	10	FMT[2:0]	√	
Clock select control	Disabled	10	CKCE		√
Attenuation rate select	$8/f_S$	10	ATS	√	√
Rolloff control for 8× digital filter	Sharp rolloff	10	FLT	√	
De-emphasis function control	De-emphasis disabled	11	DM12, -34, -56, -78	√	
De-emphasis sample rate control	44.1kHz	11	DMF[1:0]	√	
Over sampling rate control ($64 f_S$ or $128 f_S$)	$64 f_S$ oversampling	11	OVR[1:0]	√	
Output phase select	Normal phase	12	DRV12, -34, -56, -78	√	√
Zero flag polarity select	High	12	ZREV	√	
Zero flag output pin select	CH1/2 flags separately selectable	12	AZRO	√	
DSD mode control	PCM mode	12	DSD		√
System reset	Not operated	12	SRST	√	√
DSD filter select	Filter 1	13, 14	FS1[1:0] to FS8[1:0]		√
Zero flag status (read-only)	—	16	ZERO[8:1]	√	
Device ID (at TDMCA)	—	17	ID[4:0]	√	√

Table 3. Mode Control Register Map

	B15	B14	B13	B12	B11	B10	B9	B8	B7	B6	B5	B4	B3	B2	B1	B0
Register 0	R/W	0	0	0	0	0	0	0	AT17	AT16	AT15	AT14	AT13	AT12	AT11	AT10
Register 1	R/W	0	0	0	0	0	0	1	AT27	AT26	AT25	AT24	AT23	AT22	AT21	AT20
Register 2	R/W	0	0	0	0	0	1	0	AT37	AT36	AT35	AT34	AT33	AT32	AT31	AT30
Register 3	R/W	0	0	0	0	0	1	1	AT47	AT46	AT45	AT44	AT43	AT42	AT41	AT40
Register 4	R/W	0	0	0	0	1	0	0	AT57	AT56	AT55	AT54	AT53	AT52	AT51	AT50
Register 5	R/W	0	0	0	0	1	0	1	AT67	AT66	AT65	AT64	AT63	AT62	AT61	AT60
Register 6	R/W	0	0	0	0	1	1	0	AT77	AT76	AT75	AT74	AT73	AT72	AT71	AT70
Register 7	R/W	0	0	0	0	1	1	1	AT87	AT86	AT85	AT84	AT83	AT82	AT81	AT80
Register 8	R/W	0	0	0	1	0	0	0	MUT8	MUT7	MUT6	MUT5	MUT4	MUT3	MUT2	MUT1
Register 9	R/W	0	0	0	1	0	0	1	DAC8	DAC7	DAC6	DAC5	DAC4	DAC3	DAC2	DAC1
Register 10	R/W	0	0	0	1	0	1	0	RSV	FLT	ATS	RSV	CKCE	FMT2	FMT1	FMT0
Register 11	R/W	0	0	0	1	0	1	1	OVR1	OVR0	DMF1	DMF0	DM78	DM56	DM34	DM12
Register 12	R/W	0	0	0	1	1	0	0	SRST	DSD	AZRO	ZREV	DRV78	DRV56	DRV34	DRV12
Register 13	R/W	0	0	0	1	1	0	1	FS41	FS40	FS31	FS30	FS21	FS20	FS11	FS10
Register 14	R/W	0	0	0	1	1	1	0	FS81	FS80	FS71	FS70	FS61	FS60	FS51	FS50
Register 16	R	0	0	1	0	0	0	0	ZERO8	ZERO7	ZERO6	ZERO5	ZERO4	ZERO3	ZERO2	ZERO1
Register 17	R	0	0	1	0	0	0	1	RSV	RSV	RSV	ID4	ID3	ID2	ID1	ID0

DSD1608

SLES040 – JUNE 2002

Register Definitions

	B15	B14	B13	B12	B11	B10	B9	B8	B7	B6	B5	B4	B3	B2	B1	B0
Register 0	R/W	0	0	0	0	0	0	0	AT17	AT16	AT15	AT14	AT13	AT12	AT11	AT10
:																
Register 7	R/W	0	0	0	0	1	1	1	AT87	AT86	AT85	AT84	AT83	AT82	AT81	AT80

R/W Read/Write Mode Select

When R/W = 0, a write operation is performed. When R/W = 1, a read operation is performed.

ATxy Digital Attenuation Level Setting :PCM/DSD Mode

Where x = register number + 1 and y = 1 to 8, corresponding to the DAC output V_{OUT1} to V_{OUT8} . In PCM mode, the default value, 1111 1111b, represents 0 dB. Each DAC channel (V_{OUT1} to V_{OUT8}) includes a digital attenuation function. The attenuation level can be set from 0 dB to -119.5 dB in 0.5 dB steps or to $-\infty$ in PCM mode, and from 6 dB to -113.5 dB or to $-\infty$ in DSD mode. Alternatively, the attenuation level can be set to infinite attenuation (or mute). The following table shows attenuation levels for various settings.

ATxy	DECIMAL VALUE	ATTENUATION LEVEL SETTING	
		PCM Mode	DSD Mode
1111 1111b	255	0 dB, no attenuation (default)	6 dB
1111 1110b	254	-0.5 dB	5.5 dB
1111 1101b	253	-1 dB	5 dB
:	:	:	:
1111 0011b	243	-6 dB	0 dB
1111 0010b	242	-6.5 dB	-0.5 dB
:	:	:	:
1000 0011b	131	-62 dB	-56 dB
1000 0010b	130	-62.5 dB	-56.5 dB
1000 0001b	129	-63 dB	-57 dB
1000 0000b	128	-63.5 dB	-57.5 dB
:	:	:	:
0111 0101b	117	-69 dB	-63 dB
:	:	:	:
0001 0000b	16	-119.5 dB	-113.5 dB
0000 1111b	15	$-\infty$	$-\infty$
:	:	:	:
0000 0000b	0	$-\infty$	$-\infty$

	B15	B14	B13	B12	B11	B10	B9	B8	B7	B6	B5	B4	B3	B2	B1	B0
Register 8	R/W	0	0	0	1	0	0	0	MUT8	MUT7	MUT6	MUT5	MUT4	MUT3	MUT2	MUT1

R/W Read/Write Mode Select

When R/W = 0, a write operation is performed. When R/W = 1, a read operation is performed.

MUTx Soft Mute Control :PCM/DSD Mode

Where x = 1 to 8, corresponding to the DAC output V_{OUT1} to V_{OUT8} . Default value: 0

MUTx = 0	Mute disabled (default)
MUTx = 1	Mute enabled

The mute bits, MUT1 to MUT8, are used to enable or disable the soft mute function for the corresponding DAC outputs, V_{OUT1} to V_{OUT8} . The soft mute function is incorporated into the digital attenuators. When mute is disabled (MUTx = 0), the attenuator and DAC operate normally. When mute is enabled by setting MUTx = 1, the digital attenuator for the corresponding output is decreased from the current setting to infinite attenuation, one attenuator step (0.5 dB) at a time. This provides pop-free muting of the DAC output. By setting MUTx = 0, the attenuator is incremented one step at a time to the previously programmed attenuation level.

	B15	B14	B13	B12	B11	B10	B9	B8	B7	B6	B5	B4	B3	B2	B1	B0
Register 9	R/W	0	0	0	1	0	0	1	DAC8	DAC7	DAC6	DAC5	DAC4	DAC3	DAC2	DAC1

R/W Read/Write Mode Select

When R/W = 0, a write operation is performed. When R/W = 1, a read operation is performed.

DACx DAC Operation Control :PCM/DSD Mode

Where x = 1 to 8, corresponding to the DAC output V_{OUT1} to V_{OUT8} . Default value: 0

DACx = 0	DAC operation enabled (default)
DACx = 1	DAC operation disabled

The DAC operation controls are used to enable and disable the DAC outputs, V_{OUT1} to V_{OUT8} . When DACx = 0, the corresponding output generates the audio waveform dictated by the data present on the DATA pin. When DACx = 1, the corresponding output is set to the bipolar zero level, or $V_{CC} / 2$. In the TDMCA mode, the DACx bits are affected after the next PLRCK when the write operation occurs.

	B15	B14	B13	B12	B11	B10	B9	B8	B7	B6	B5	B4	B3	B2	B1	B0
Register 10	R/W	0	0	0	1	0	1	0	RSV	FLT	ATS	RSV	CKCE	FMT2	FMT1	FMT0

R/W Read/Write Mode Select

When R/W = 0, a write operation is performed. When R/W = 1, a read operation is performed.

RSV Reserved Bit

The RSV bit must be set to 0.

FLT Digital Filter Roll-Off Control :PCM Mode

Default value: 0

FLT = 0	Sharp rolloff (default)
FLT = 1	Slow rolloff

The FLT bit allows the user to select the digital filter rolloff that is best suited to a particular application. Two filter rolloff selections are available: sharp and slow. The filter responses for these selections are shown in the *Typical Performance Curves* section of this data sheet.

ATS Attenuation Rate Select :PCM/DSD Mode

Default value: 0

ATS = 0	$8/f_S$ (default)
ATS = 1	$16/f_S$

The ATS bit is used to select the rate at which the attenuator is decremented / incremented during level transitions.

CKCE Clock Select Control :DSD Mode

Default value: 0

CKCE = 0	System clock is applied to PSCK in the DSD mode (default).
CKCE = 1	System clock is applied to DSCK in the DSD mode.

The CKCE bit selects the system clock source in the DSD mode (PSCK or DSCK). The CKCE bit must be set before the DSD bit in register 12 can be set to 1.

FMT[2:0] Audio Interface Data Format :PCM Mode

Default value: 000. The FMT[2:0] bits are used to select the data format for the serial audio interface. The table below shows the available format options.

DSD1608

SLES040 – JUNE 2002

FMT[2:0]	Audio Data Format Select
000	24-bit standard format, right-justified data (default)
001	20-bit standard format, right-justified data
010	18-bit standard format, right-justified data
011	16-bit standard format, right-justified data
100	I ² S format, 24 bits
101	Left-justified format, 24 bits
110	Reserved
111	Reserved

	B15	B14	B13	B12	B11	B10	B9	B8	B7	B6	B5	B4	B3	B2	B1	B0
Register 11	R/W	0	0	0	1	0	1	1	OVR1	OVR0	DMF1	DMF0	DM78	DM56	DM34	DM12

R/W Read/Write Mode Select

When R/W = 0, a write operation is performed. When R/W = 1, a read operation is performed.

OVR[1:0] Delta-Sigma Oversampling Rate Select

Default value: 0

OVR[1:0]	Oversampling Rate Select
00	64× f _S (default)
01	128× f _S
1x	32× f _S

The OVR[1:0] bits are used to change the oversampling rate of delta-sigma modulation. This function makes it easy to design a post-low-pass filter for any sampling rate.

DMF[1:0] De-Emphasis Sampling Frequency Select

Default value: 0

DMF[1:0]	De-Emphasis Sampling Frequency Select
00	44.1 kHz (default)
01	48 kHz
10	32 kHz
11	Reserved

The DMF[1:0] bits are used to select the sampling frequency for the digital de-emphasis function when de-emphasis is enabled.

DMxx De-Emphasis Function Control

Default value: 0

DMxx = 0	De-emphasis function disabled (default)
DMxx = 1	De-emphasis function enabled

The DMxx bits are used to enable or disable the digital de-emphasis function of selected channel pairs. Suffix 12, 34, 56, 78 means Channel 1 and 2, 3 and 4, 5 and 6, and 7 and 8 respectively. See the plots shown in the *Typical Performance Curves* section of this data sheet.

	B15	B14	B13	B12	B11	B10	B9	B8	B7	B6	B5	B4	B3	B2	B1	B0
Register 12	R/W	0	0	0	1	1	0	0	SRST	DSD	AZRO	ZREV	DRV78	DRV56	DRV34	DRV12

DSD1608

SLES040 – JUNE 2002

R/W Read/Write Mode Select

When R/W = 0, a write operation is performed. When R/W = 1, a read operation is performed.

FSxy DSD Filter Select :DSD Mode

Default value: 00

FSxy	DSD Filter Select
00	Filter 1 (default)
01	Filter 2
10	Filter 3
11	Reserved

The FSxy bits allow selection of the DSD filter from three kind of filters for each channel. The x suffix in the register name designates the channel, from 1 to 8, for which the filter is being selected. The y suffix in the register name designates the high or low bit of the filter selection value.

	B15	B14	B13	B12	B11	B10	B9	B8	B7	B6	B5	B4	B3	B2	B1	B0
Register 16	R	0	0	1	0	0	0	0	ZERO8	ZERO7	ZERO6	ZERO5	ZERO4	ZERO3	ZERO2	ZERO1

R Read Only

ZEROx Zero Flag

ZEROx = 0	Not zero detected on indexed channel
ZEROx = 1	Zero detected on indexed channel

The ZEROx bits indicate indexed the result of ZERO detection circuit of each channels.

	B15	B14	B13	B12	B11	B10	B9	B8	B7	B6	B5	B4	B3	B2	B1	B0
Register 17	R	0	0	1	0	0	0	1	RSV	RSV	RSV	ID4	ID3	ID2	ID1	ID0

R Read Only

RSV Reserve Bit

The RSV bit is read as 0.

ID[4:0] Device ID

The ID[4:0] bits show a device ID in TDMCA mode.

ANALOG OUTPUTS

The DSD1608 includes eight independent output channels: V_{OUT1} to V_{OUT8} . These are unbalanced outputs, each capable of driving 4 V_{p-p} typical into a 10-k Ω ac-coupled load. The internal output amplifiers for V_{OUT1} to V_{OUT8} are biased to the dc common-mode (or bipolar zero) voltage, equal to $V_{CC}/2$.

The output amplifiers include an RC continuous-time filter, which helps to reduce the out-of-band noise energy present at the DAC outputs due to the noise shaping characteristics of the DSD1608 delta-sigma D/A converters. The frequency response of this filter is shown in Figure 30. By itself, this filter is not enough to attenuate the out-of-band noise to an acceptable level for many applications. An external low-pass filter is required to provide sufficient out-of-band noise rejection. Further discussion of DAC post-filter circuits is provided in the *Applications Information* section of this data sheet.

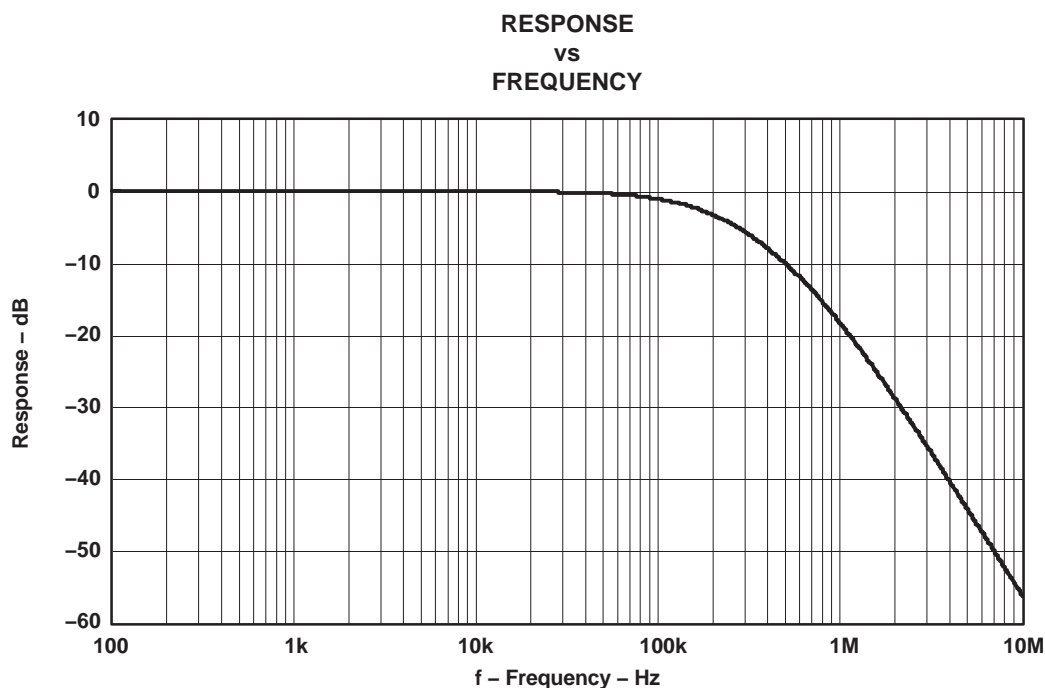

Figure 30. Analog Output Filter Performance (100 Hz–10 MHz)

ZERO FLAGS

The DSD1608 includes circuitry for detecting an all-zero data condition for the audio data input pin and output pins for indicating the result.

Zero Detect Condition

Zero detection for each channel or combination of channels is independent from any other.

In PCM mode, if the data for a given channel or channel combination remains at a 0 level for 1024 sample periods (or PLRCK clock periods), a zero-detect condition exists for that channel or combination of channels.

In DSD mode, zero detection is not available.

Zero Output Flags

Given that a zero-detect condition exists for each channel or combination of channels, the zero flag pins for those conditions will be set to a logic 1 state. There are three zero flag pins for channel 1, ZERO1 (pin 6), for channel 2, ZERO2 (pin 7) and for a logical AND of channels 3 through 8, ZERO38 (pin 8). These pins can be used to operate external mute circuits, or used as status indicators for a microcontroller, audio signal processor, or other digitally controlled circuit.

The active polarity of the zero flag outputs can be inverted by setting the ZREV bit of control register 12 to 1. The reset default is active-high output, or ZREV = 0.

APPLICATION INFORMATION

CONNECTION DIAGRAMS

A basic connection diagram is shown in Figure 31, with the necessary power supply bypass and decoupling components.

The use of series resistors ($22\ \Omega$ to $100\ \Omega$) is recommended for the xSCK, PLRCK, xBCK, PDATAx, and DSDx inputs. The series resistor combines with the stray PCB and device input capacitance to form a low-pass filter which reduces high-frequency noise emissions and helps to dampen glitches and ringing present on clock and data lines.

POWER SUPPLIES AND GROUNDING

The DSD1608 requires a 5-V analog supply and a 3.3-V digital supply. The 5-V supply is used to power the DAC analog and output filter circuitry, while the 3.3-V supply is used to power the digital filter and serial interface circuitry. For best performance, the 3.3-V digital supply should be derived from the 5-V supply by using a linear regulator. Texas Instruments' REG1117-3.3 is an ideal choice for this application.

Proper power supply bypassing is shown in Figure 31. The $10\text{-}\mu\text{F}$ capacitors should be tantalum or aluminum electrolytic, while the $0.1\text{-}\mu\text{F}$ capacitors are ceramic (the X7R type is recommended for surface-mount applications).

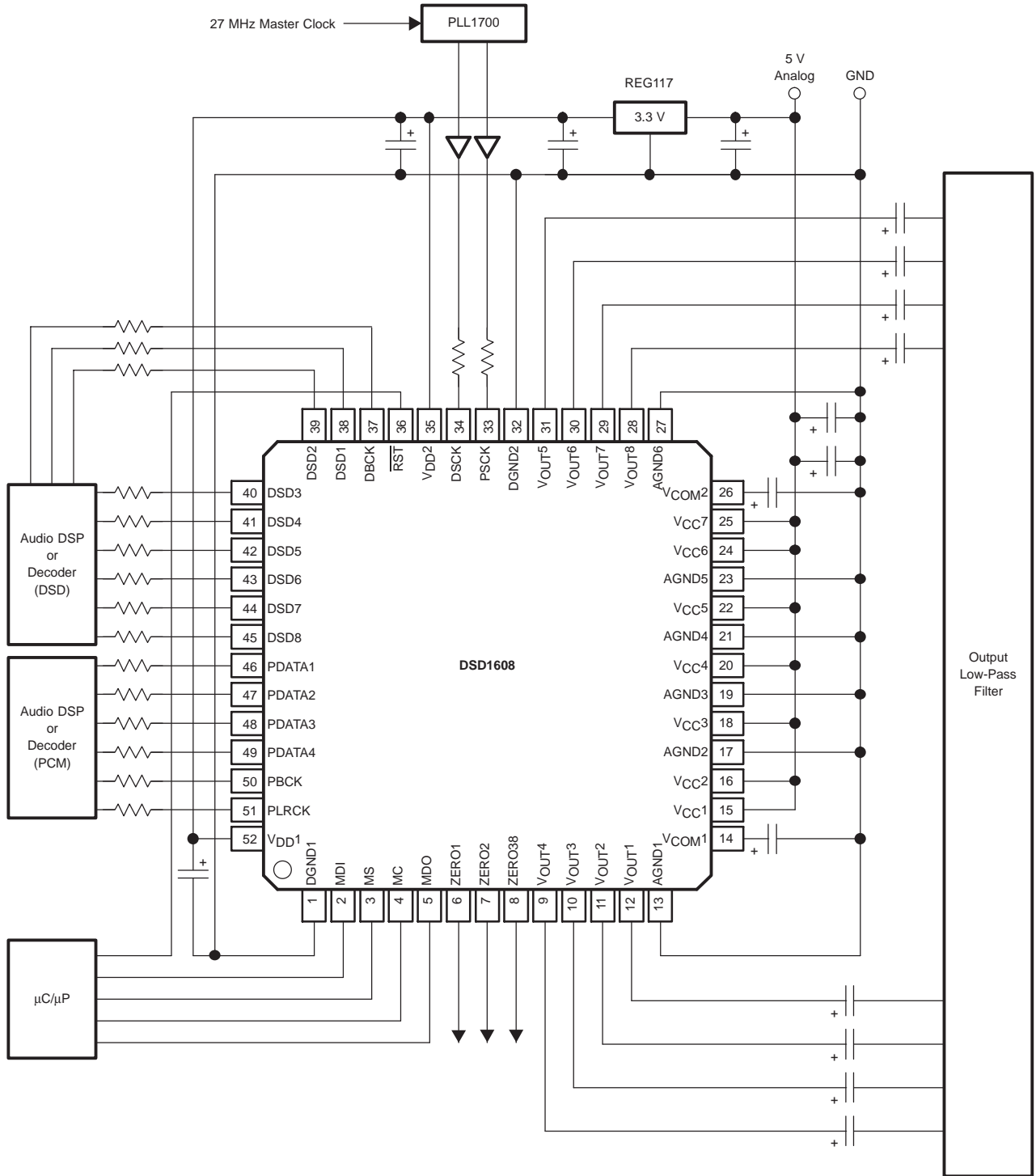

Figure 31. Basic Connection Diagram

D/A OUTPUT FILTER CIRCUITS: POST-LOW-PASS FILTER

The DSD1608 requires a third- or second-order analog low-pass filter to achieve the frequency response recommended by the SACD standard and reduce the out-of-band noise produced by the delta-sigma modulator. Figure 32 shows the recommended external low-pass filter circuit. This circuit is a third-order Butterworth filter using the Sallen-Key circuit arrangement. The filter response and corner frequency are determined by the frequency response recommended by the SACD standard. Figure 32 lists the standard values for resistors and capacitors corresponding with the DSD digital filter on DSD1608. This filter can be used in either the PCM or the DSD modes.

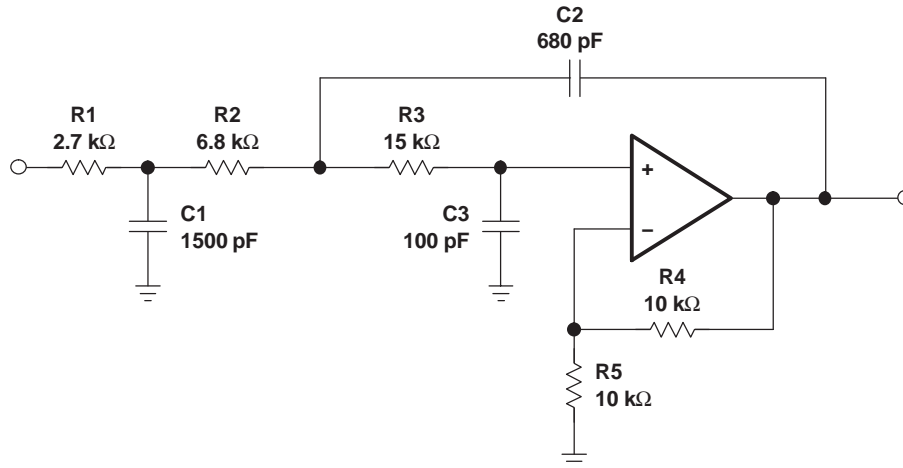

Figure 32. Post-Low-Pass Filter Circuit

TDMCA FORMAT

The DSD1608 supports the time division multiplexed command and audio data (TDMCA) format to reduce any host control serial interface. The TDMCA format is designed for not only McBSP of TI DSPs but also any programmable devices. The TDMCA format can transfer not only audio data but also command data so that it can be used with any kind of device that supports the TDMCA format. The TDMCA frame consists of a command field, extended command field, and some audio data fields. The audio data are transported to IN devices (such as DAC) and/or from OUT devices (such as ADC). The DSD1608 is an IN device. PLRCK and PBCK are shared both IN and OUT devices so that the sample frequency must be united in one system. The TDMCA mode supports a maximum of 30 device IDs. The maximum number of audio channel depends on the PBCK frequency.

TDMCA Mode Determination

The DSD1608 recognizes the TDMCA mode by receiving PLRCK which pulse width is two PBCK clocks. The DSD1608 goes into the TDMCA after two continuous TDMCA frames. Figure 33 shows the PLRCK and PBCK timing required for the TDMCA mode. Any TDMCA commands can be issued the next TDMCA frame after entering the TDMCA mode. If operation in the TDMCA mode operation is not required, PLRCK must be a 50%-duty-cycle square wave.

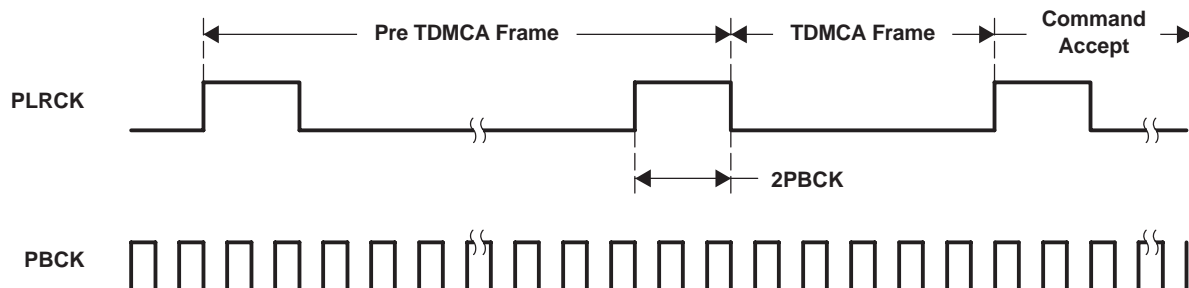

Figure 33. PLRCK and PBCK Timing for the TDMCA Mode

TDMCA Terminals

TDMCA requires six signals, of which four are for command and audio data interface and two are for the daisy chain. Signals that can be shared are as indicated in the following table. The host interface signals, MS, MC and MDO change to DCI, DCO, and PDO respectively. The MDO signal is 3-state output so that it can be connected directly to other PDO terminals.

TERMINAL (SIGNAL) NAME	PROPERTY	DESCRIPTION
PLRCK	Input	TDMCA frame-start signal. The frequency of PLRCK must be the same as the sampling frequency.
PBCK	Input	TDMCA clock. The frequency of PBCK must be high enough to communicate the TDMCA frame within a PLRCK clock cycle.
PDATA1/PDI	Input	TDMCA command and audio data input signal
MDO/PDO	Output	TDMCA command data three-state output signal
MS/DCI	Input	TDMCA daisy chain input signal
MC/DCO	Output	TDMCA daisy chain output signal

Device ID Determination

The TDMCA mode also supports a multi-chip implementation in one system. This means that the host controller (DSP) can support several PCM devices and/or other devices simultaneously. The PCM devices are categorized as IN device, OUT device, IN/OUT device, and NO device. The IN device has an input port to receive audio data. The OUT device has a output port to provide audio data. The IN/OUT device has both input and output ports for audio data. The NO device has no port for audio data but needs command data from the host. A DAC is an IN device, an ADC is an OUT device, a CODEC is an IN/OUT device, and a PLL is a NO device. The DSD1608 is an IN device. To distinguish devices from the host controller, each device is given its own device ID by the daisy chain. A device gets its own device ID automatically by connecting its DCO to the DCI of the next device in the daisy chain. There are actually two completely independent and equivalent daisy chains, which are categorized as the IN chain and the OUT chain. Figure 34 shows the daisy chain connection. If a system needs to chain a DSD1608 and a NO device in the same IN chain, the NO device should be chained at the back of the IN chain because it doesn't require any audio data. Figure 35 shows an example of a TDMCA system that includes an IN chain and an OUT chain with a TI DSP. For chained devices to get their own device IDs, the DID signal should be set to 1 (the details are described later) and PLRCK and PBCK should be driven to initiate the TDMCA mode for all devices which are chained. The device at the top of the chain determines its device ID is 1 when DCI is fixed HIGH. Every other device determines its position in the chain by counting PBCK pulses and observing its own DCI signal. Figure 36 shows the initialization of each device ID. If all devices do not need separate device IDs, each DCI should be held high, causing the corresponding device IDs to be 1.

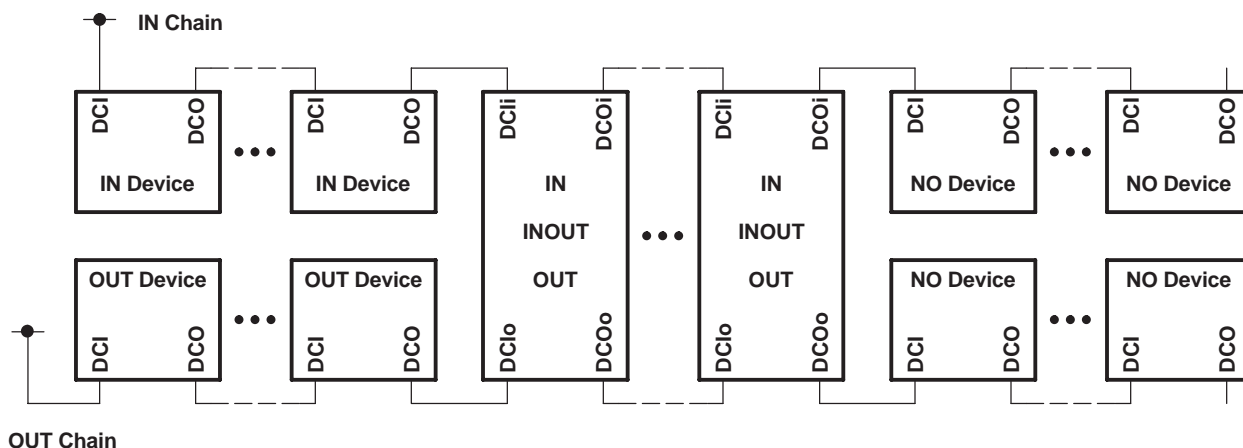

Figure 34. Daisy Chain Connection

DSD1608

SLES040 – JUNE 2002

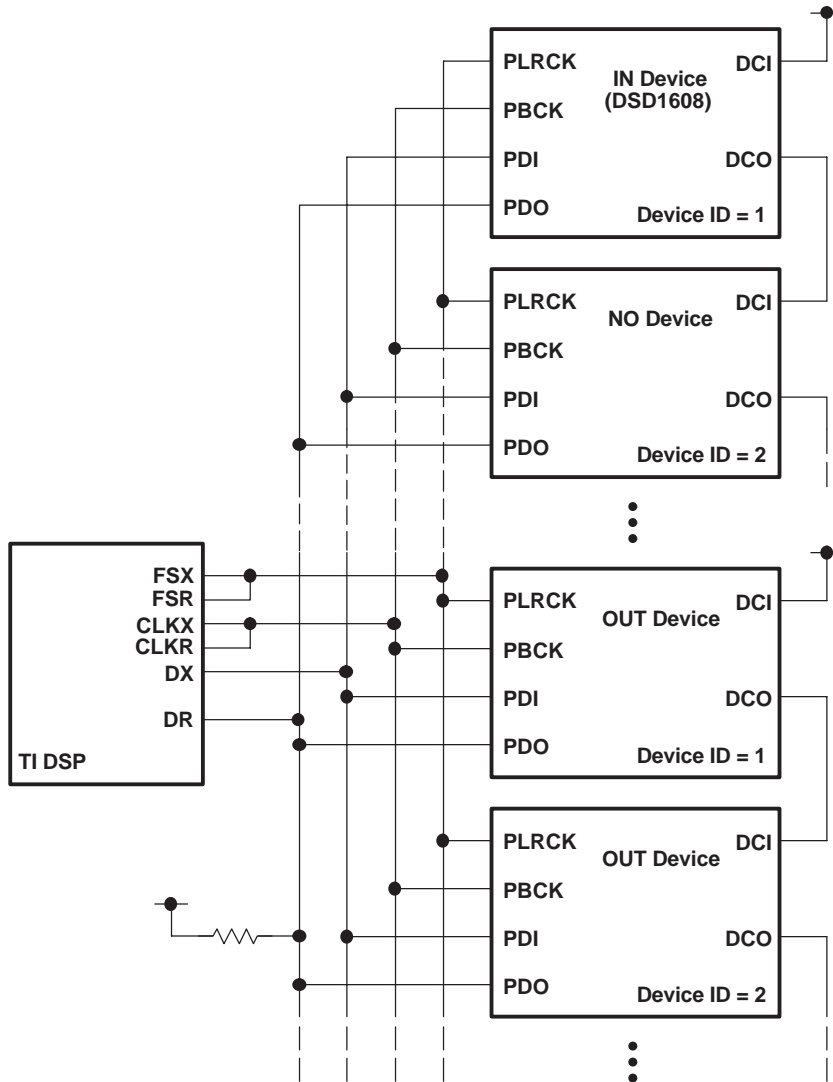

Figure 35. IN and OUT Daisy Chain Connection for Multichip System

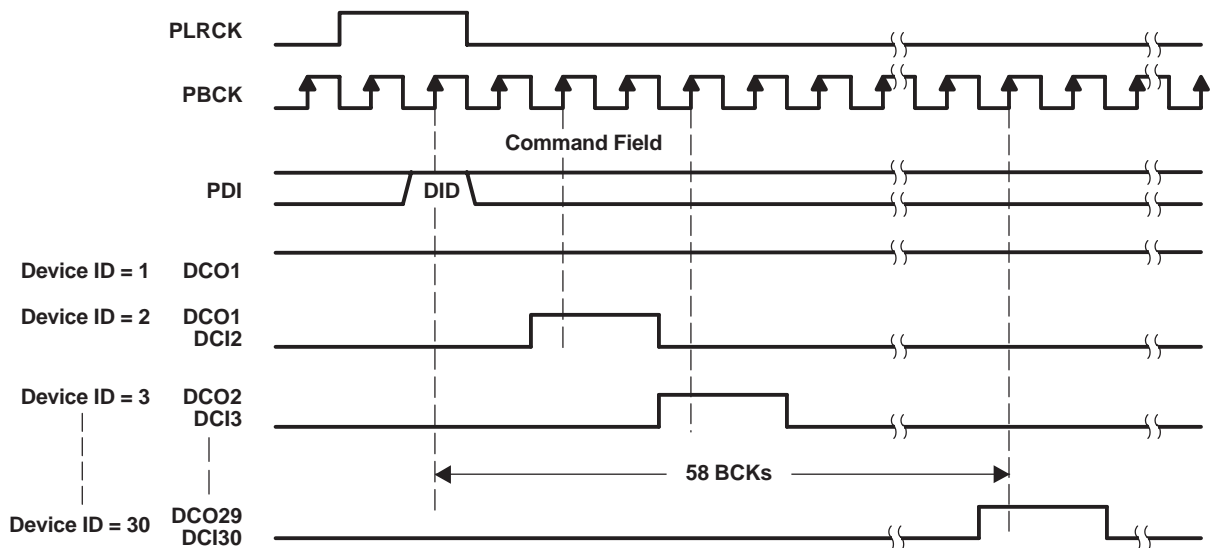

Figure 36. Device ID Determination Sequence

TDMCA Frame

In general, the TDMCA frame consists of a command field, an extended command (EMD) field, and an audio data field. All fields are 32 bits in length, but the LS byte has no meaning. The MSB is transferred first for each field. The command field is always transferred as the first packet of the frame. The EMD field is transferred if the EMD flag of the command field is high. If any EMD packets are transferred, no audio data follow after those EMD packets. This frame is for quick initialization. All devices of the daisy chain should respond to the command field and extended command field. The DSD1608 has eight audio channels that can be selected in register 41. If the corresponding flags are preset low, those audio channels are transferred. Figure 37 shows a general TDMCA frame. If some DACs are enabled although the corresponding audio data packets are not transferred, the analog outputs of those DACs are unpredictable.

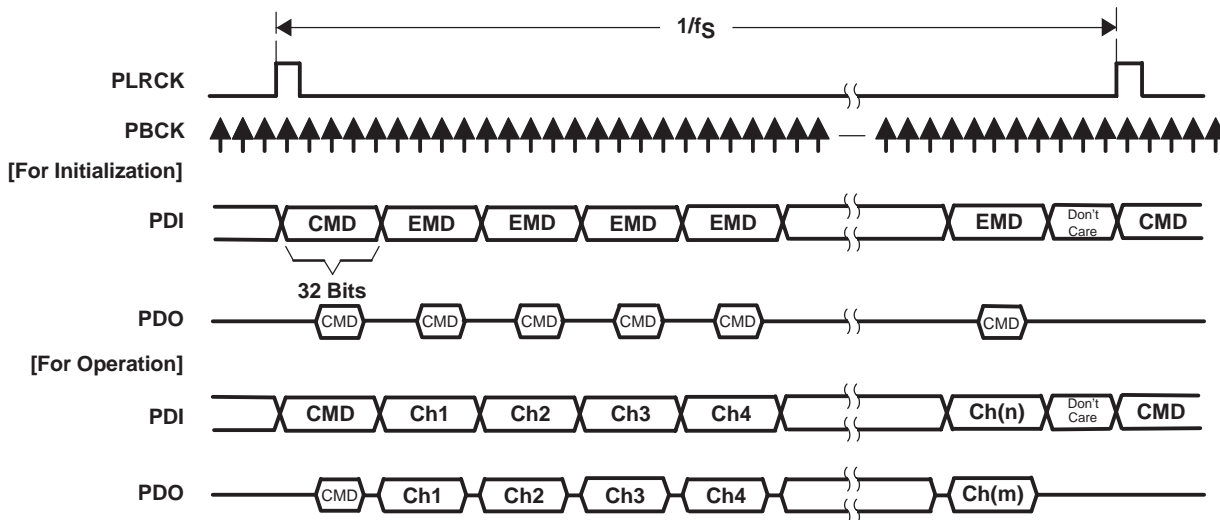

Figure 37. General TDMCA Frame

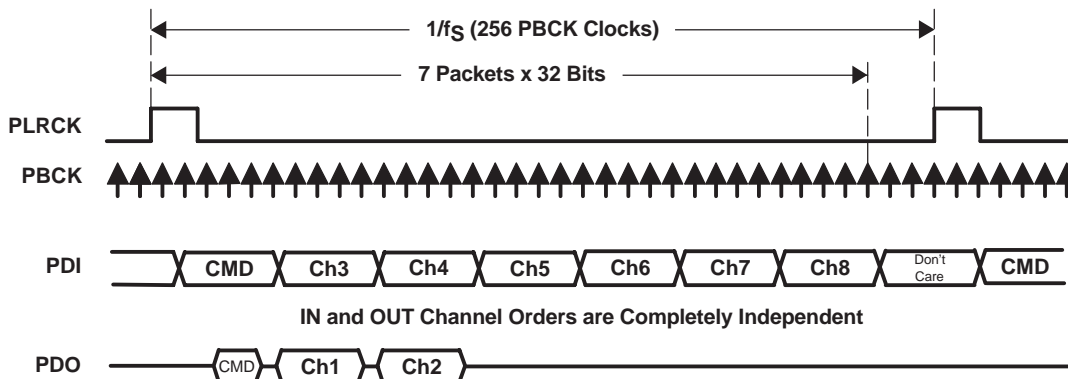

Figure 38. TDMCA Frame Example of 6-Ch DAC and 2-Ch ADC With Command Read

DSD1608

SLES040 – JUNE 2002

Command Field

The command field is defined as follows. The DID field (MSB) has another meaning, that this frame is for device ID determination.

31	30	29	28	24	23	22	21	20	16	15	8	7	0
command	DID	EMD	DCS	Device ID	R/W	Register ID	Data	Not used					

Bit 31: Device ID Enable Flag

The DSD1608 operates to get its own device ID if this bit is HIGH. This is for TDMCA initialization.

Bit 30: Extended Command Enable Flag

An EMD packet is transferred if this bit is HIGH, otherwise skipped. When the bit is HIGH, this frame does not contain any audio data. This is for system initialization.

Bit 29: Daisy Chain Selection Flag

HIGH means OUT chain devices, LOW means IN chain devices. The DSD1608 is an IN device, so the DCS bit must be set to LOW.

Bit [28:24]: Device ID

The device ID is 5 bits in length, and it can be defined. IDs of devices follow the order of an IN or OUT daisy chain. The top device of the daisy chain has device ID 1 and the next device in the chain has device ID 2, etc. The ID for any device that has its DCI set HIGH is also 1. The maximum device ID each in the IN or OUT chain is 30. If a device ID is 0x1F, all devices are selected as broadcast when in the write mode. If any device ID is 0x00, no device is selected.

Bit 23: Command Read/Write Flag

If it is HIGH, the command is a read operation.

Bit [22:16]: Register ID

The register ID is 7 bits in length. See Table 3.

Bit [15:8]: Command Data

The command data is 8 bits in length. Any valid data can be chosen for each register. See Table 3.

Bit [7:0]: Not used

These bits are never transported when a read operation is performed.

Extended Command Field

The extended command field is almost the same as the command field. The only difference is that it does not have a DID flag.

31	30	29	28	24	23	22	21	20	16	15	8	7	0
Extended command	RSVD	EMD	DCS	Device ID	R/W	Register ID	Data	Not Used					

Audio Field

The audio field is 32 bits in length and the audio data is transferred MSB first. When transferring audio data of less than 32 bits, the unused portion of the field must be padded with 0s, as the following figure shows.

31	16	12	8	7	0
Audio data	MSB	24 bits	LSB	All 0s	
	MSB	20 bits	LSB	All 0s	
	MSB	16 bits	LSB	All 0s	

TDMCA Register Requirements

The TDMCA mode requires device ID and audio channel information, previously described. Register 9 indicates the audio channels and register 17 indicates the device ID. Register 17 is used only in the TDMCA mode. See the *Mode Control Register Map*, Table 3.

Register Write/Read Operation

The command supports register write and read operations. If the command requests to read one register, the read data is transferred on PDO during the data phase portion of the timing cycle. The PDI signal can be retrieved on the positive edge of PBCK and the PDO signal is driven on the negative edge of PBCK. The PDO is activated one cycle early due to compensate for the output delay caused by high impedance. Figure 39 shows the TDMCA write and read timing.

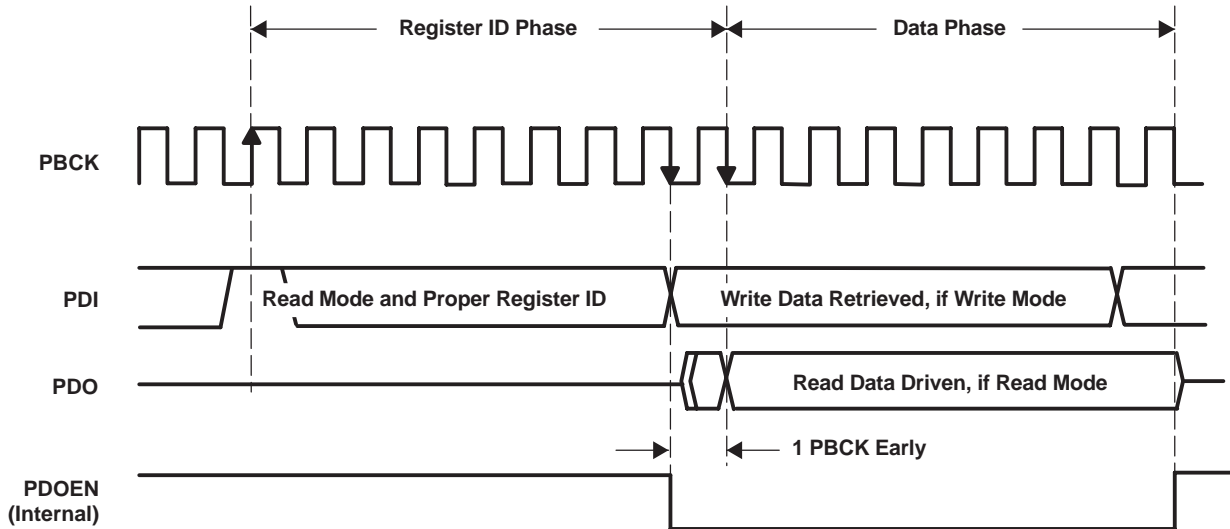

Figure 39. TDMCA Write and Read Operation Timing

TDMCA Mode Operation

DCO specifies the owner of the next audio channel in TDMCA operation. When one device retrieves its own audio channel data, the DCO becomes HIGH during last audio channel period. Figure 40 shows the DCO output timing during a TDMCA-mode operation. The host controller is not affected by the behavior of DCI and DCO. DCO indicates the last audio channel of each device. Therefore, DCI means that the next audio channel is allocated.

DSD1608

SLES040 – JUNE 2002

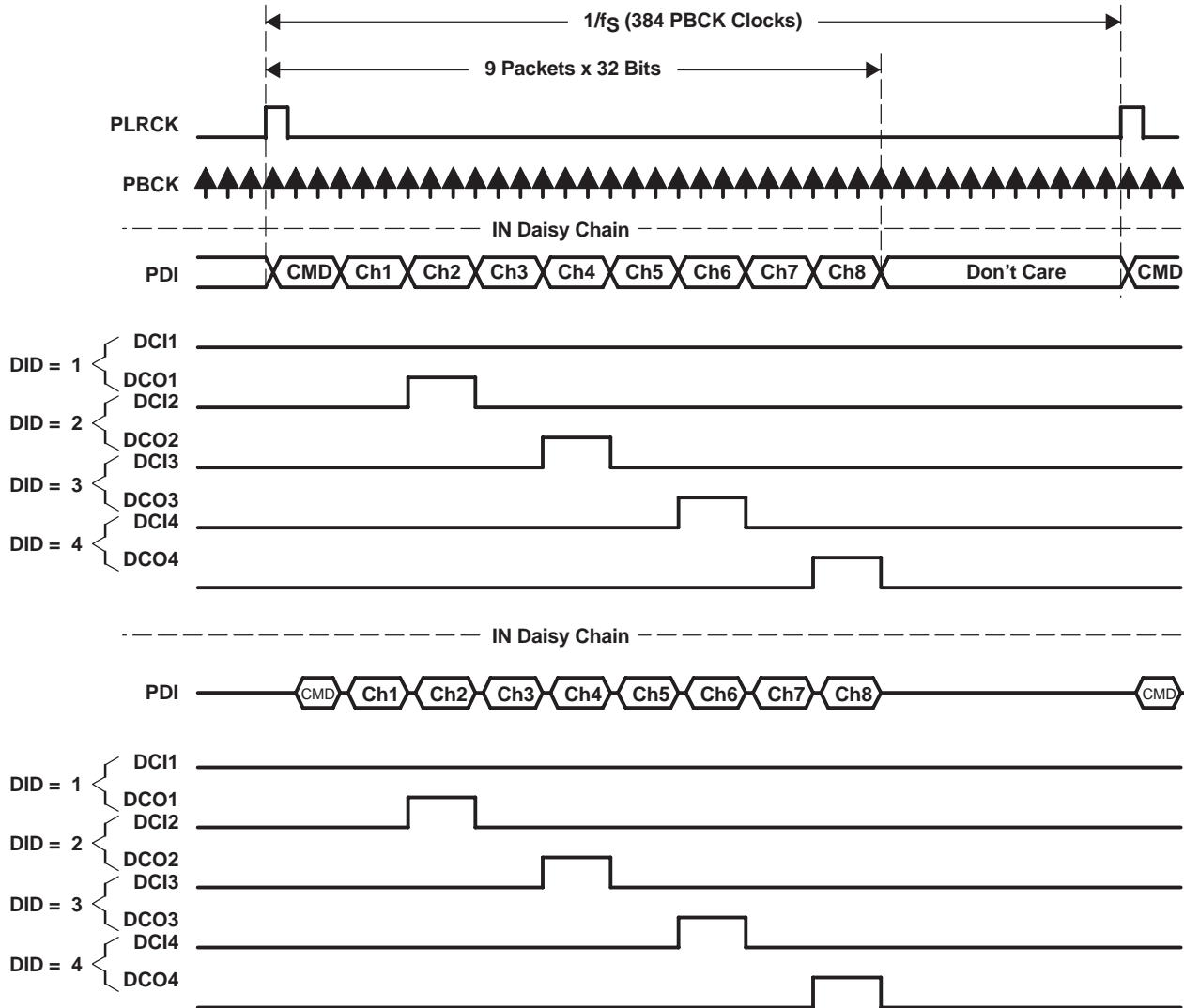

Figure 40. DCO Output Timing in TDMCA-Mode Operation

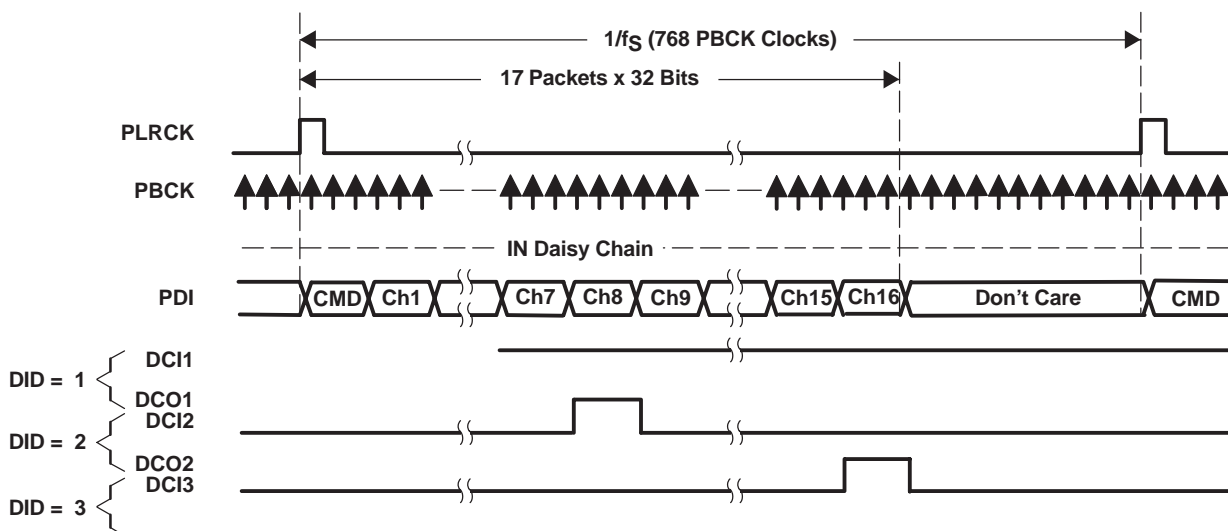

Figure 41. DCO Output Timing Example for 16-Ch Audio Data of Two DSD1608s

If some devices are skipped due to lack of an active audio channel, each skipped device must notify the next device that the DCO will be passed through the next DCI. Figure 42 and Figure 43 show DCO timing with skip operation. Figure 44 shows the ac timing of daisy chain signals.

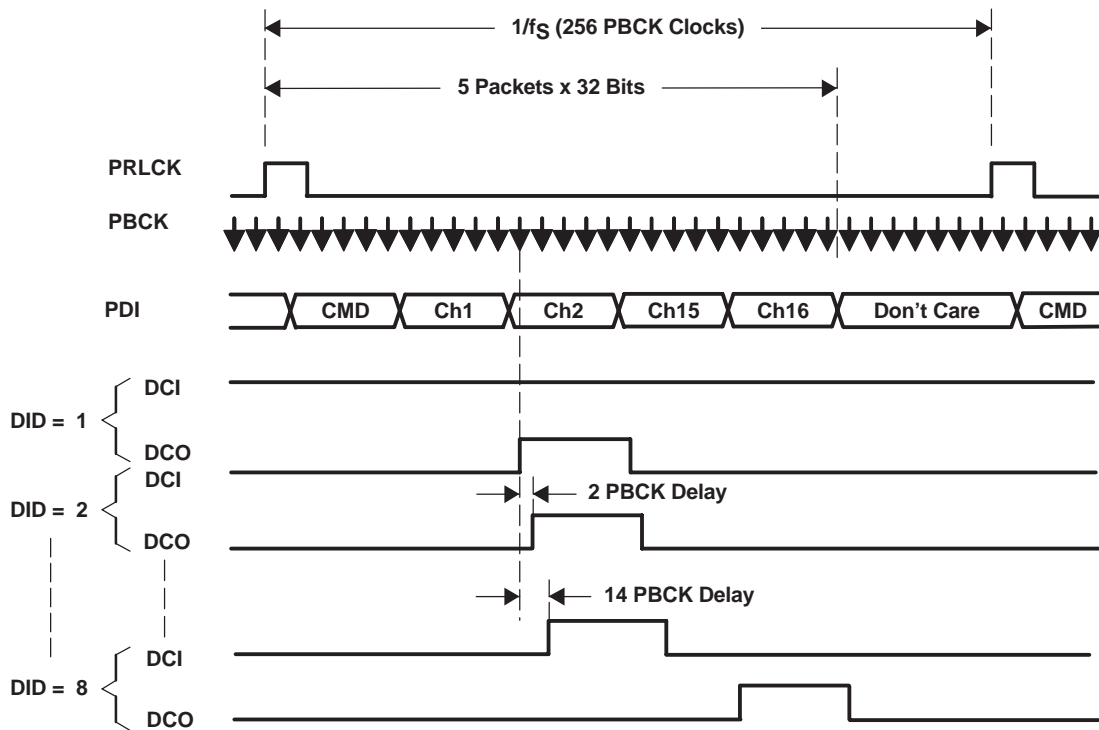

Figure 42. DCO Output Timing With Skip Operation

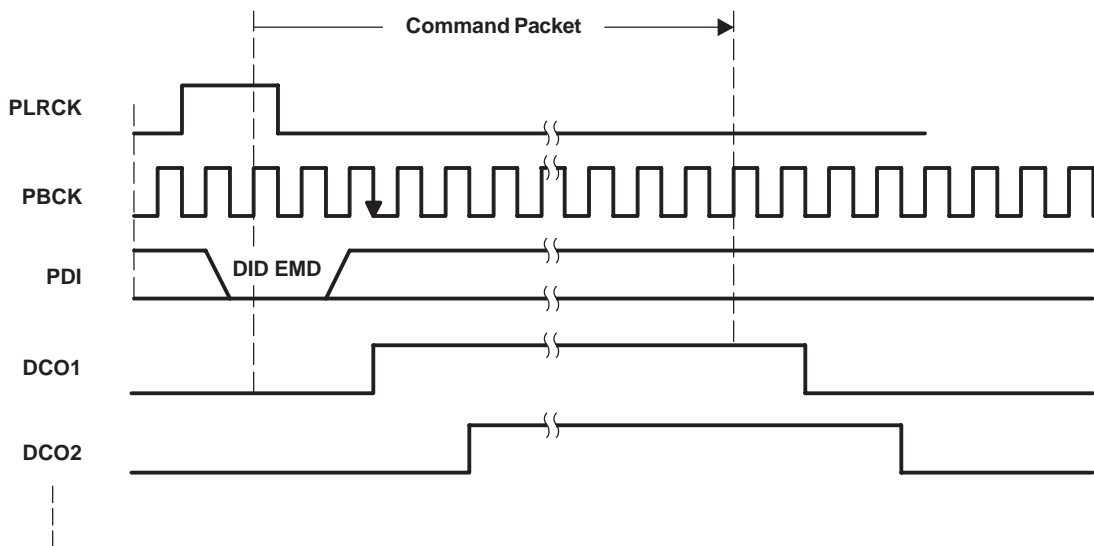
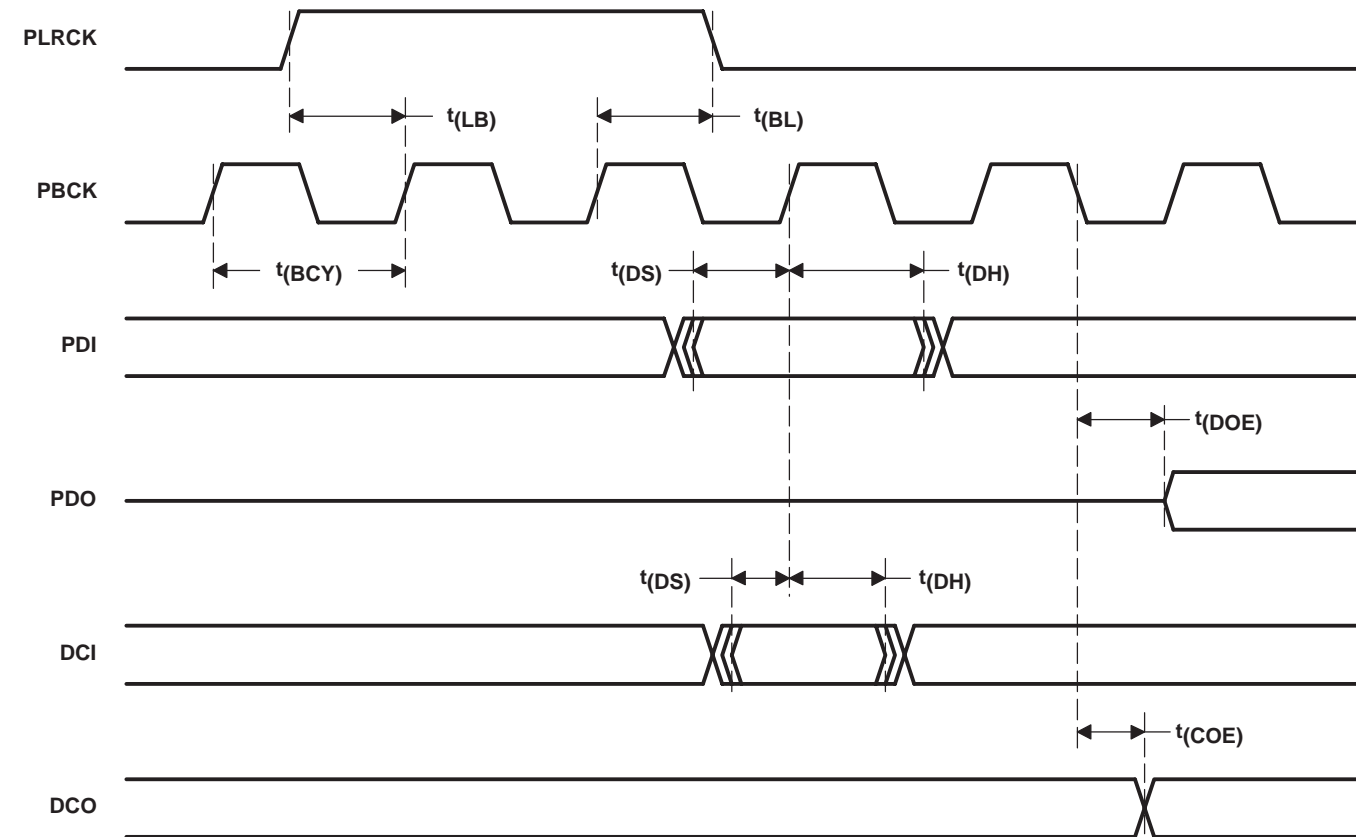

Figure 43. DCO Output Timing With Skip Operation (for Command Packet 1)

DSD1608

SLES040 – JUNE 2002



SYMBOL	PARAMETERS	MIN	MAX	UNIT
$t(BCY)$	PBCK pulse cycle time	20		ns
$t(LB)$	PLRCK setup time	0		ns
$t(BL)$	PLRCK hold time	3		ns
$t(DS)$	PDI setup time	0		ns
$t(DH)$	PDI hold time	3		ns
$t(DS)$	DCI setup time	0		ns
$t(DH)$	DCI hold time	3		ns
$t(DOE)$	PDO output delay ⁽¹⁾		8	ns
$t(COE)$	DCO output delay ⁽¹⁾		6	ns

(1) Load capacitance is 10 pF.

Figure 44. AC Timing of Daisy Chain Signals

HOST CONTROL FLOW

The host controller can control the TDMCA mode as follows:

1. Decides daisy chain to initialize PLRCK and PBCCK signals generator
2. Generates TDMCA mode determination sequence
3. Sets DID flag in command to fix device ID automatically
4. Checks all device IDs if necessary
5. Initializes all devices
6. Communicates audio data and commands

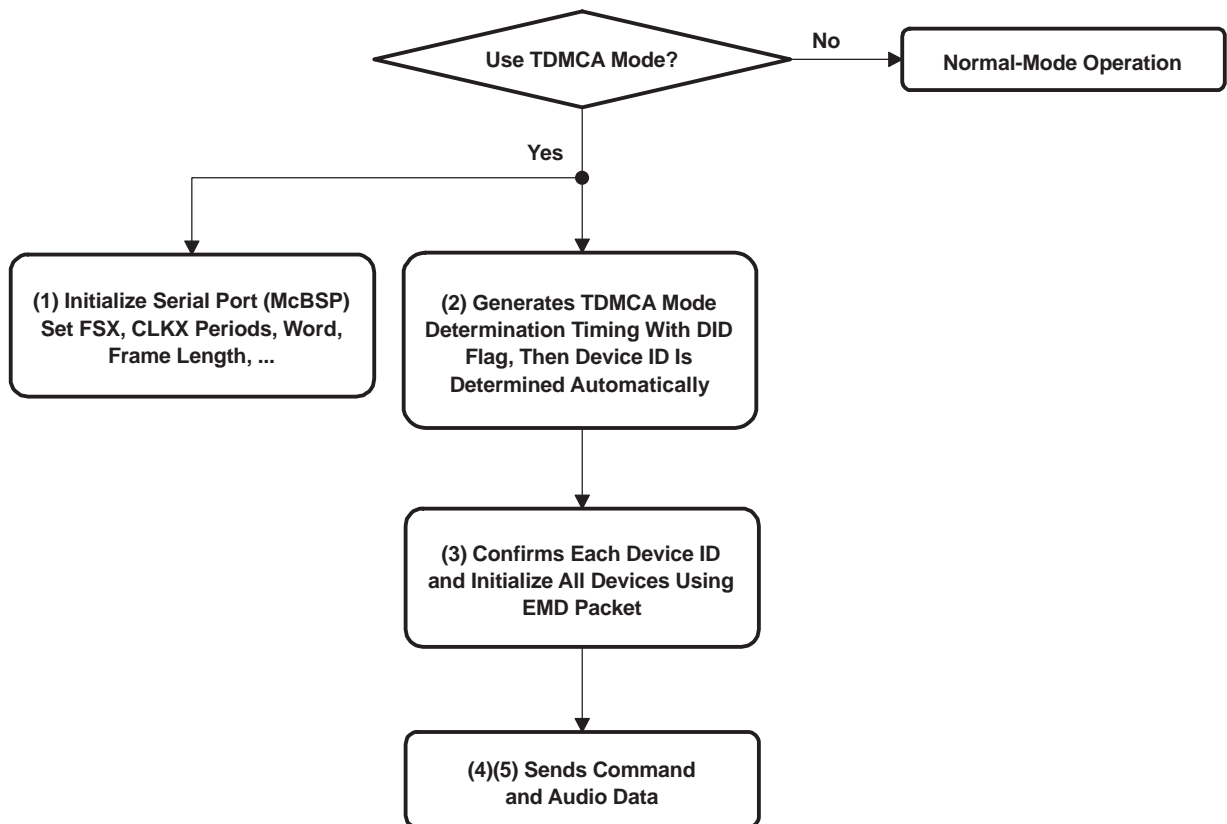

Figure 45. TDMCA Control Flow From Host

DSD1608

SLES040 – JUNE 2002

MECHANICAL DATA

PAH (S-PQFP-G52)

PLASTIC QUAD FLATPACK

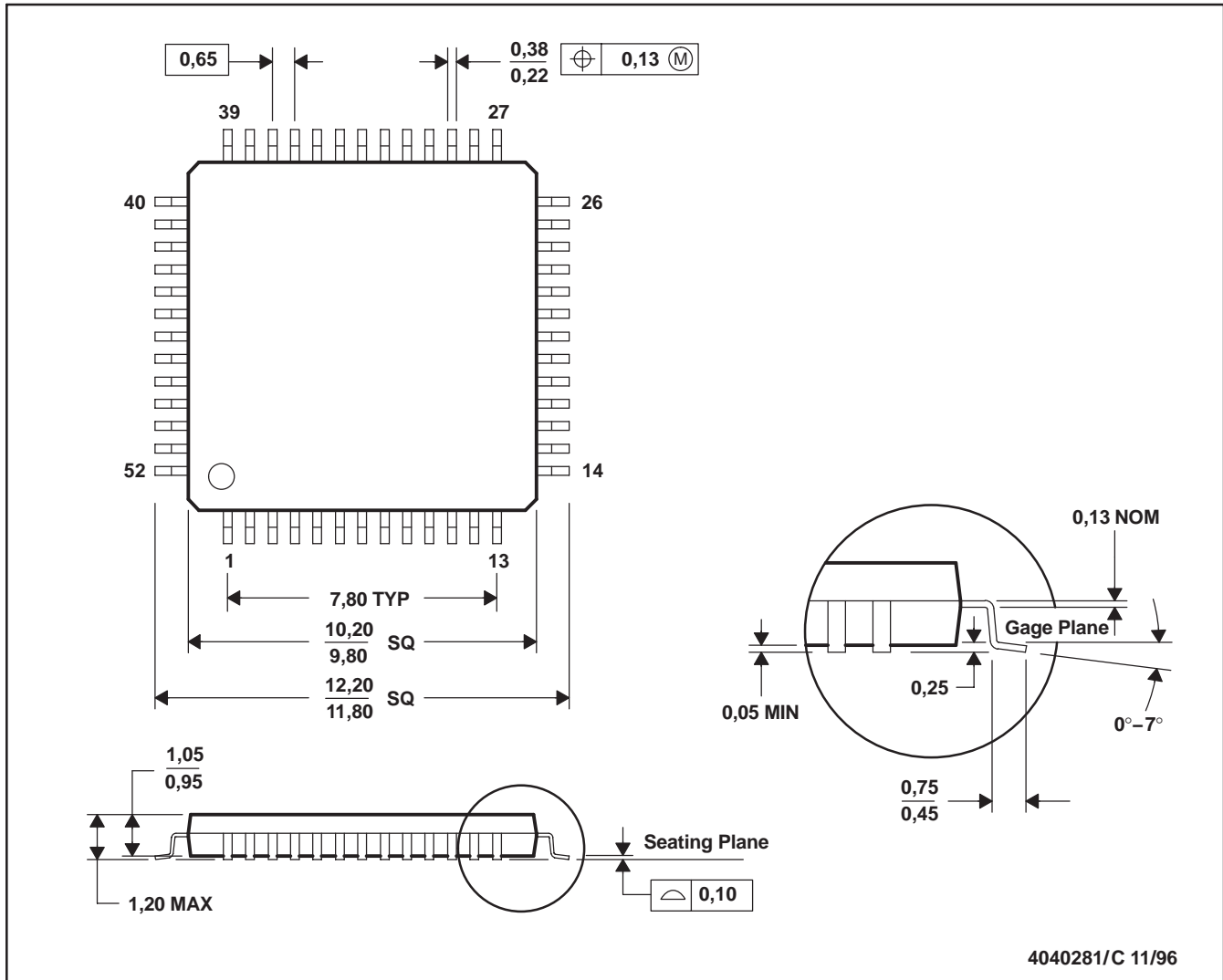

4040281/C 11/96

- NOTES: A. All linear dimensions are in millimeters.
 B. This drawing is subject to change without notice.
 C. Falls within JEDEC MS-026

PACKAGING INFORMATION

Orderable Device	Status ⁽¹⁾	Package Type	Package Drawing	Pins	Package Qty	Eco Plan ⁽²⁾	Lead/Ball Finish	MSL Peak Temp ⁽³⁾
DSD1608PAH	ACTIVE	TQFP	PAH	52	160	Green (RoHS & no Sb/Br)	CU NIPDAU	Level-3-260C-168 HR
DSD1608PAHG4	ACTIVE	TQFP	PAH	52	160	Green (RoHS & no Sb/Br)	CU NIPDAU	Level-3-260C-168 HR
DSD1608PAHR	ACTIVE	TQFP	PAH	52	1500	Green (RoHS & no Sb/Br)	CU NIPDAU	Level-3-260C-168 HR
DSD1608PAHRG4	ACTIVE	TQFP	PAH	52	1500	Green (RoHS & no Sb/Br)	CU NIPDAU	Level-3-260C-168 HR

⁽¹⁾ The marketing status values are defined as follows:

ACTIVE: Product device recommended for new designs.

LIFEBUY: TI has announced that the device will be discontinued, and a lifetime-buy period is in effect.

NRND: Not recommended for new designs. Device is in production to support existing customers, but TI does not recommend using this part in a new design.

PREVIEW: Device has been announced but is not in production. Samples may or may not be available.

OBSOLETE: TI has discontinued the production of the device.

⁽²⁾ Eco Plan - The planned eco-friendly classification: Pb-Free (RoHS), Pb-Free (RoHS Exempt), or Green (RoHS & no Sb/Br) - please check <http://www.ti.com/productcontent> for the latest availability information and additional product content details.

TBD: The Pb-Free/Green conversion plan has not been defined.

Pb-Free (RoHS): TI's terms "Lead-Free" or "Pb-Free" mean semiconductor products that are compatible with the current RoHS requirements for all 6 substances, including the requirement that lead not exceed 0.1% by weight in homogeneous materials. Where designed to be soldered at high temperatures, TI Pb-Free products are suitable for use in specified lead-free processes.

Pb-Free (RoHS Exempt): This component has a RoHS exemption for either 1) lead-based flip-chip solder bumps used between the die and package, or 2) lead-based die adhesive used between the die and leadframe. The component is otherwise considered Pb-Free (RoHS compatible) as defined above.

Green (RoHS & no Sb/Br): TI defines "Green" to mean Pb-Free (RoHS compatible), and free of Bromine (Br) and Antimony (Sb) based flame retardants (Br or Sb do not exceed 0.1% by weight in homogeneous material)

⁽³⁾ MSL, Peak Temp. -- The Moisture Sensitivity Level rating according to the JEDEC industry standard classifications, and peak solder temperature.

Important Information and Disclaimer:The information provided on this page represents TI's knowledge and belief as of the date that it is provided. TI bases its knowledge and belief on information provided by third parties, and makes no representation or warranty as to the accuracy of such information. Efforts are underway to better integrate information from third parties. TI has taken and continues to take reasonable steps to provide representative and accurate information but may not have conducted destructive testing or chemical analysis on incoming materials and chemicals. TI and TI suppliers consider certain information to be proprietary, and thus CAS numbers and other limited information may not be available for release.

In no event shall TI's liability arising out of such information exceed the total purchase price of the TI part(s) at issue in this document sold by TI to Customer on an annual basis.

TAPE AND REEL INFORMATION

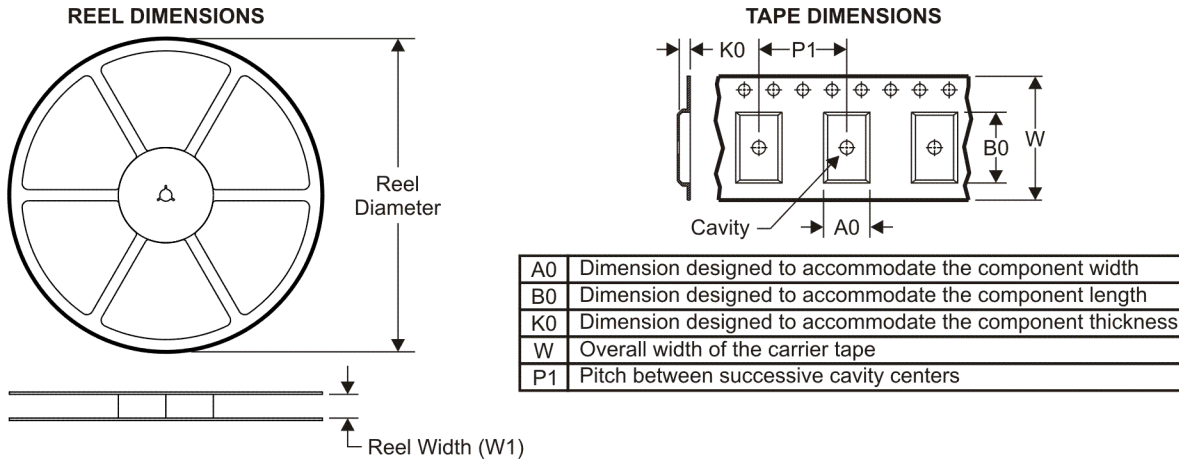

QUADRANT ASSIGNMENTS FOR PIN 1 ORIENTATION IN TAPE

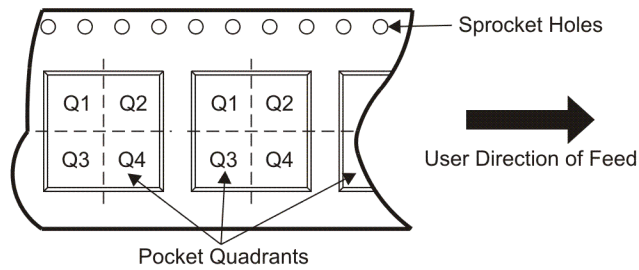

*All dimensions are nominal

Device	Package Type	Package Drawing	Pins	SPQ	Reel Diameter (mm)	Reel Width W1 (mm)	A0 (mm)	B0 (mm)	K0 (mm)	P1 (mm)	W (mm)	Pin1 Quadrant
DSD1608PAHR	TQFP	PAH	52	1500	330.0	25.4	12.35	12.35	1.65	16.0	24.0	Q2

TAPE AND REEL BOX DIMENSIONS

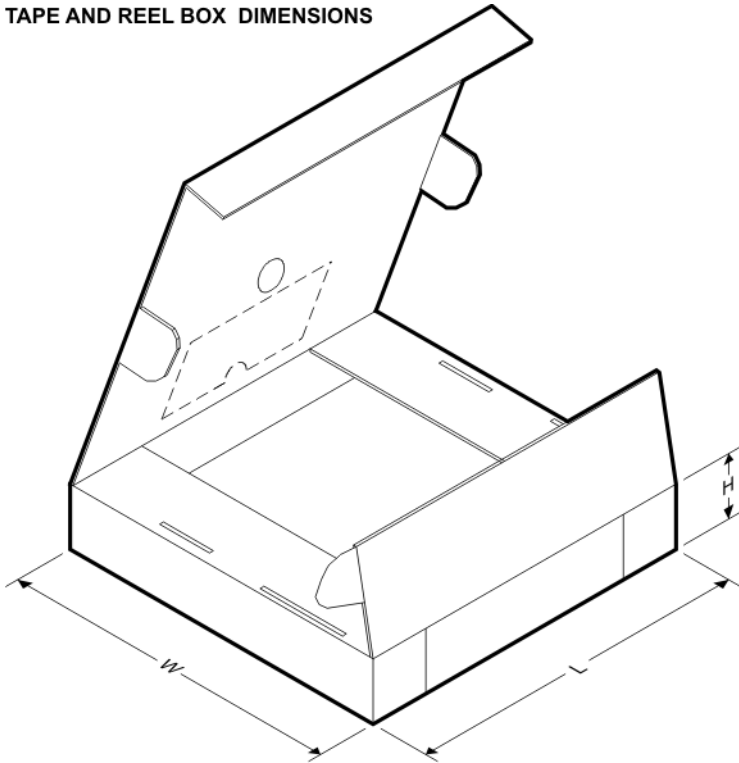

*All dimensions are nominal

Device	Package Type	Package Drawing	Pins	SPQ	Length (mm)	Width (mm)	Height (mm)
DSD1608PAHR	TQFP	PAH	52	1500	346.0	346.0	41.0

IMPORTANT NOTICE

Texas Instruments Incorporated and its subsidiaries (TI) reserve the right to make corrections, modifications, enhancements, improvements, and other changes to its products and services at any time and to discontinue any product or service without notice. Customers should obtain the latest relevant information before placing orders and should verify that such information is current and complete. All products are sold subject to TI's terms and conditions of sale supplied at the time of order acknowledgment.

TI warrants performance of its hardware products to the specifications applicable at the time of sale in accordance with TI's standard warranty. Testing and other quality control techniques are used to the extent TI deems necessary to support this warranty. Except where mandated by government requirements, testing of all parameters of each product is not necessarily performed.

TI assumes no liability for applications assistance or customer product design. Customers are responsible for their products and applications using TI components. To minimize the risks associated with customer products and applications, customers should provide adequate design and operating safeguards.

TI does not warrant or represent that any license, either express or implied, is granted under any TI patent right, copyright, mask work right, or other TI intellectual property right relating to any combination, machine, or process in which TI products or services are used. Information published by TI regarding third-party products or services does not constitute a license from TI to use such products or services or a warranty or endorsement thereof. Use of such information may require a license from a third party under the patents or other intellectual property of the third party, or a license from TI under the patents or other intellectual property of TI.

Reproduction of TI information in TI data books or data sheets is permissible only if reproduction is without alteration and is accompanied by all associated warranties, conditions, limitations, and notices. Reproduction of this information with alteration is an unfair and deceptive business practice. TI is not responsible or liable for such altered documentation. Information of third parties may be subject to additional restrictions.

Resale of TI products or services with statements different from or beyond the parameters stated by TI for that product or service voids all express and any implied warranties for the associated TI product or service and is an unfair and deceptive business practice. TI is not responsible or liable for any such statements.

TI products are not authorized for use in safety-critical applications (such as life support) where a failure of the TI product would reasonably be expected to cause severe personal injury or death, unless officers of the parties have executed an agreement specifically governing such use. Buyers represent that they have all necessary expertise in the safety and regulatory ramifications of their applications, and acknowledge and agree that they are solely responsible for all legal, regulatory and safety-related requirements concerning their products and any use of TI products in such safety-critical applications, notwithstanding any applications-related information or support that may be provided by TI. Further, Buyers must fully indemnify TI and its representatives against any damages arising out of the use of TI products in such safety-critical applications.

TI products are neither designed nor intended for use in military/aerospace applications or environments unless the TI products are specifically designated by TI as military-grade or "enhanced plastic." Only products designated by TI as military-grade meet military specifications. Buyers acknowledge and agree that any such use of TI products which TI has not designated as military-grade is solely at the Buyer's risk, and that they are solely responsible for compliance with all legal and regulatory requirements in connection with such use.

TI products are neither designed nor intended for use in automotive applications or environments unless the specific TI products are designated by TI as compliant with ISO/TS 16949 requirements. Buyers acknowledge and agree that, if they use any non-designated products in automotive applications, TI will not be responsible for any failure to meet such requirements.

Following are URLs where you can obtain information on other Texas Instruments products and application solutions:

Products

Amplifiers	amplifier.ti.com
Data Converters	dataconverter.ti.com
DSP	dsp.ti.com
Clocks and Timers	www.ti.com/clocks
Interface	interface.ti.com
Logic	logic.ti.com
Power Mgmt	power.ti.com
Microcontrollers	microcontroller.ti.com
RFID	www.ti-rfid.com
RF/IF and ZigBee® Solutions	www.ti.com/lprf

Applications

Audio	www.ti.com/audio
Automotive	www.ti.com/automotive
Broadband	www.ti.com/broadband
Digital Control	www.ti.com/digitalcontrol
Medical	www.ti.com/medical
Military	www.ti.com/military
Optical Networking	www.ti.com/opticalnetwork
Security	www.ti.com/security
Telephony	www.ti.com/telephony
Video & Imaging	www.ti.com/video
Wireless	www.ti.com/wireless

Mailing Address: Texas Instruments, Post Office Box 655303, Dallas, Texas 75265
Copyright © 2008, Texas Instruments Incorporated

Looking for pricing, stock, or lifecycle information?

Click below to explore more details on WIN SOURCE:

 [View DSD1608PAHR on WIN SOURCE](#)

 [Texas Instruments](#) Information

Optimize Your Supply Chain with WIN SOURCE Solutions

-  Global Sourcing Solution
-  Obsolete Management
-  Cost Control Management
-  Shortage Management
-  Alternative Solution
-  Excess Inventory Management