



**THE DATASHEET OF
P78E03-1000**



**CUI INC**

a bel group

date 03/22/2023

page 1 of 7

SERIES: P78E-1000 | **DESCRIPTION:** NON-ISOLATED DC SWITCHING REGULATOR**FEATURES**

- 1 A of output current
- efficiency up to 96%
- industry standard SIP package
- industrial operating temp -40~+85°C
- drop in equivalent LM78 regulator
- no load input current of 0.2 mA
- output short circuit protection on output
- designed to meet EN/BS EN 62368

**MODEL**

MODEL	input voltage ¹		output voltage (Vdc)	output current max (mA)	output power max (W)	ripple & noise ² max (mVp-p)	efficiency ³ typ (%)
	typ (Vdc)	range (Vdc)					
P78E03-1000	24	6~36	3.3	1000	3.3	75	90
P78E05-1000	24	8~36	5	1000	5	75	93
	12	8~27	-5	-500	2.5	75	85
P78E09-1000	24	13~36	9	1000	9	75	94
P78E12-1000	24	16~36	12	1000	12	75	95
	12	8~20	-12	-300	3.6	75	88
P78E15-1000	24	20~36	15	1000	15	75	96
	12	8~18	-15	-300	4.5	75	87

- Notes:
1. For input voltages higher than 30 Vdc, a 22 μ F / 50 V input capacitor is required.
 2. Tested at nominal input, 20~100% load, 20 MHz bandwidth, with 10 μ F electrolytic and 1 μ F ceramic capacitor on the output. At loads below 20%, the max ripple and noise of the 3.3 & 5 Vdc outputs will be 100 mVp-p, and the other outputs will be 2% Vo.
 3. Measured at min Vin, full load.
 4. All specifications are measured at Ta=25°C, humidity < 75%, nominal input voltage, and rated output load unless otherwise specified.

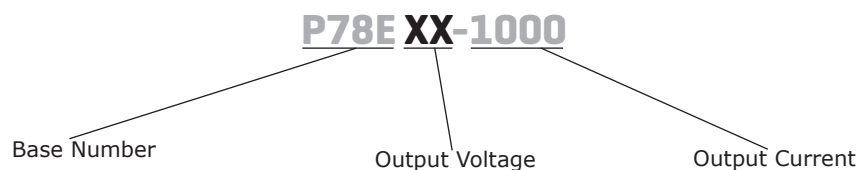
PART NUMBER KEY

INPUT

parameter	conditions/description	min	typ	max	units
operating input voltage ⁵	for positive output applications	6		36	Vdc
	for negative output applications	8		27	Vdc
filter	capacitor filter				
input reverse polarity protection	no				
no-load input current	positive outputs		0.3	1	mA
	negative outputs		1	4	mA

Note: 5. See Model section on page 1 for specific input voltage ranges.

OUTPUT

parameter	conditions/description	min	typ	max	units
maximum capacitive load ⁶	for positive output applications			680	μF
	for negative output applications			330	μF
voltage accuracy	at full load, input voltage range		±2	±4	%
	3.3 Vdc output model		±1.5	±3	%
	all other models				
line regulation	at full load, input voltage range		±0.2	±0.4	%
load regulation	at nominal input, 10~100% load				
	positive output applications		±0.4	±0.6	%
	negative output applications		±0.4	±0.8	%
switching frequency	at nominal input voltage, full load		520		kHz
transient recovery time	at nominal input voltage, 25% load step change			1	ms
transient response deviation	at nominal input voltage		±60	±200	mV
temperature coefficient	at full load			±0.03	%/°C

Note: 6. The maximum capacitive load was tested at nominal input voltage, full load.

PROTECTIONS

parameter	conditions/description	min	typ	max	units
short circuit protection	continuous, auto recovery				

SAFETY AND COMPLIANCE

parameter	conditions/description	min	typ	max	units
safety approvals	designed to meet 62368: EN/BS EN				
conducted emissions	CISPR32/EN55032, class B (external circuit required, see Figure 4/5-b)				
radiated emissions	CISPR32/EN55032, class B (external circuit required, see Figure 4/5-b)				
ESD	IEC/EN61000-4-2, contact ± 4kV, class B				
radiated immunity	IEC/EN61000-4-3, 10V/m, class A				
EFT/burst	IEC/EN61000-4-4, ± 1kV, class B (external circuit required, see Figure 4/5-a)				
surge	IEC/EN61000-4-5, line-line ± 1kV, class B (external circuit required, see Figure 4/5-a)				
conducted immunity	IEC/EN61000-4-6, 3 Vr.m.s, class A				
MTBF	as per MIL-HDBK-217F, 25°C	2,000,000			hours
RoHS	yes				

ENVIRONMENTAL

parameter	conditions/description	min	typ	max	units
operating temperature	see derating curves	-40		85	°C
storage temperature		-55		125	°C
storage humidity	non-condensing			95	%

SOLDERABILITY

parameter	conditions/description	min	typ	max	units
wave soldering	see wave soldering profile			260	°C

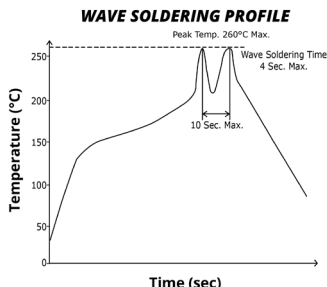

MECHANICAL

parameter	conditions/description	min	typ	max	units
dimensions	11.6 x 8.0 x 10.40 [0.457 x 0.315 x 0.409 inch]				mm
case material	black flame-retardant and heat-resistant plastic (UL94 V-0)				
weight			1.9		g

MECHANICAL DRAWING

units: mm [inch]
tolerance: ±0.50[±0.020]
pin diameter tolerance: ±0.10[±0.004]

PIN CONNECTIONS		
PIN	+OUTPUT	-OUTPUT
1	+VIN	+VIN
2	GND	-VOUT
3	+VOUT	GND

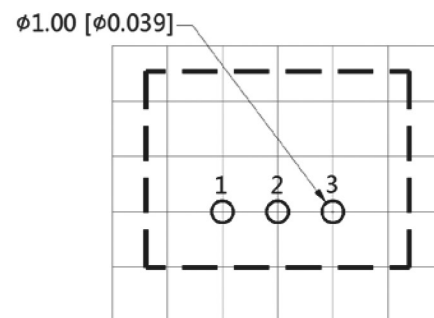
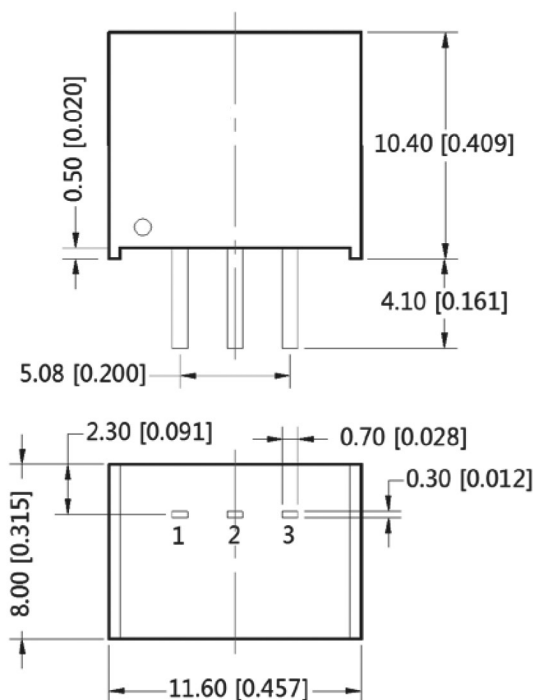

Note : Grid 2.54*2.54mm
Recommended PCB Layout
Top View

DERATING CURVES

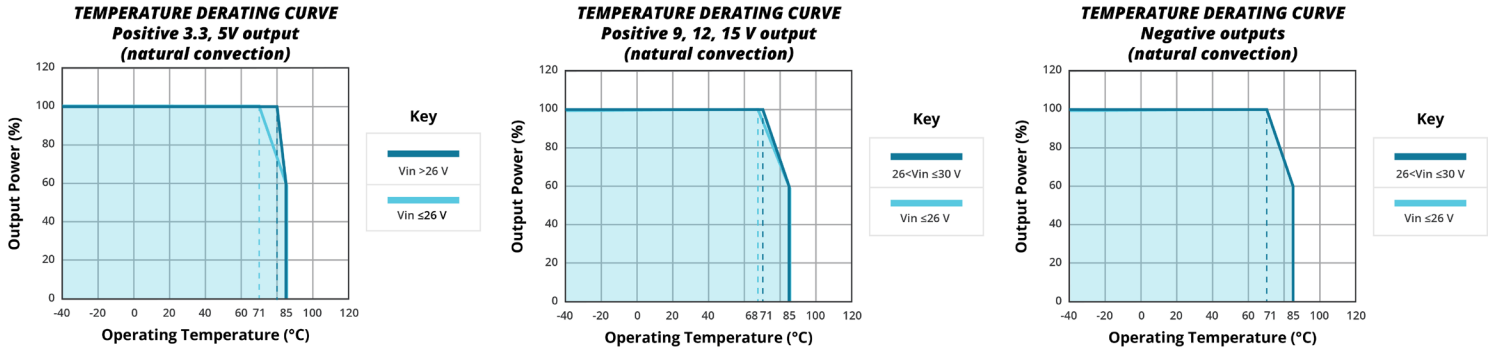

EFFICIENCY CURVES

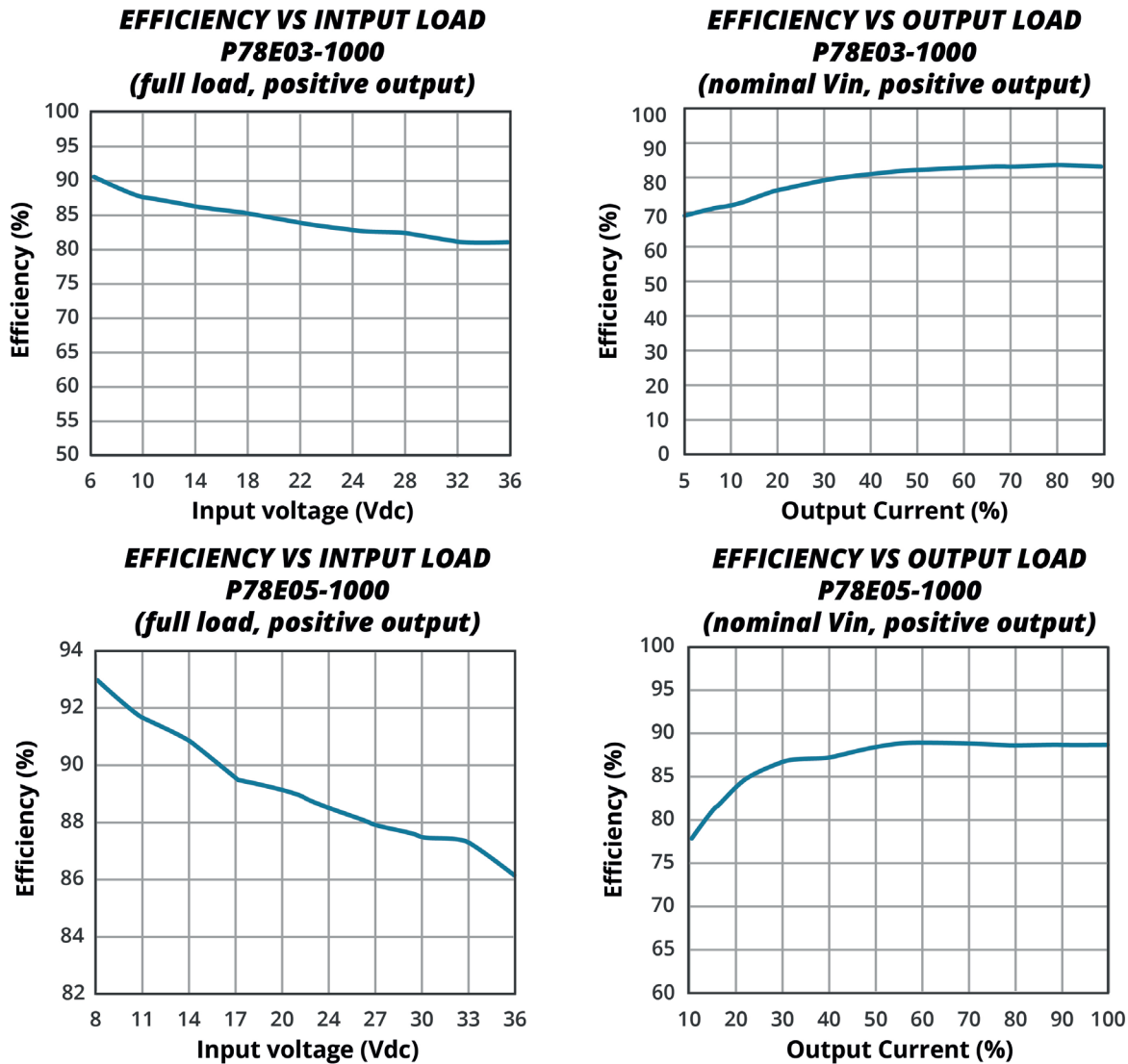

EFFICIENCY CURVES (CONTINUED)

**EFFICIENCY VS INPUT LOAD
P78E09-1000
(full load, positive output)**

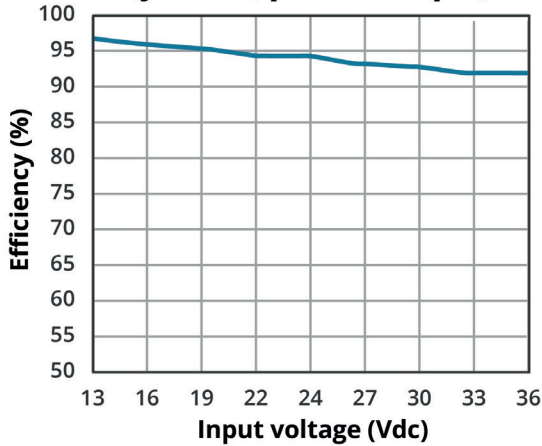

**EFFICIENCY VS OUTPUT LOAD
P78E09-1000
(nominal Vin, positive output)**

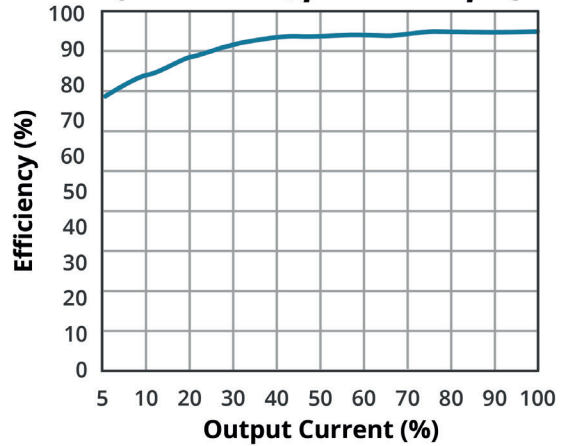

**EFFICIENCY VS INPUT LOAD
P78E12-1000
(full load, positive output)**

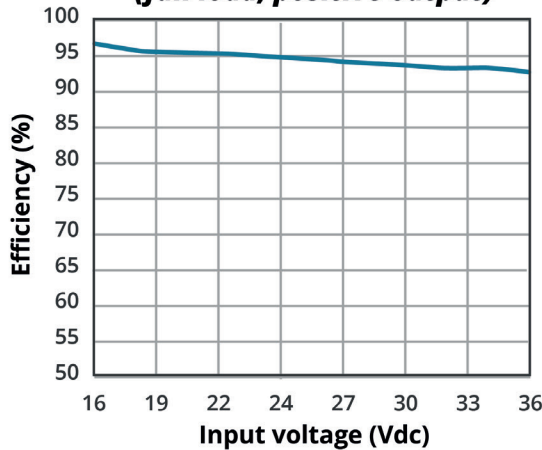

**EFFICIENCY VS OUTPUT LOAD
P78E12-1000
(nominal Vin, positive output)**

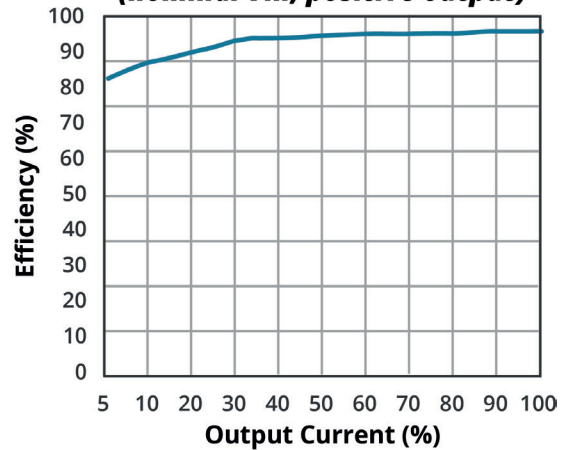

**EFFICIENCY VS INPUT LOAD
P78E15-1000
(full load, positive output)**

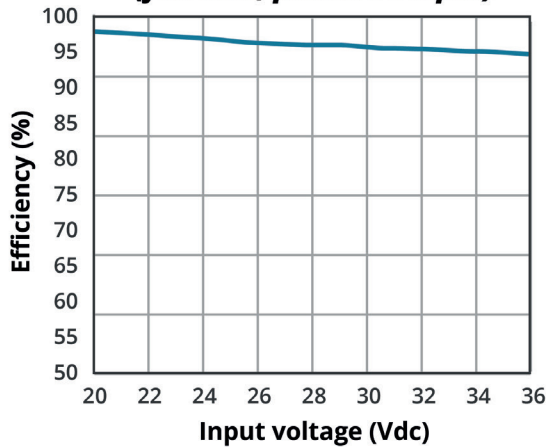

**EFFICIENCY VS OUTPUT LOAD
P78E15-1000
(nominal Vin, positive output)**

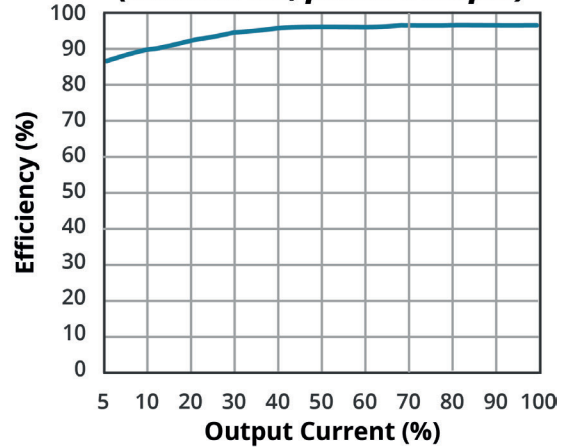

TYPICAL APPLICATION CIRCUIT

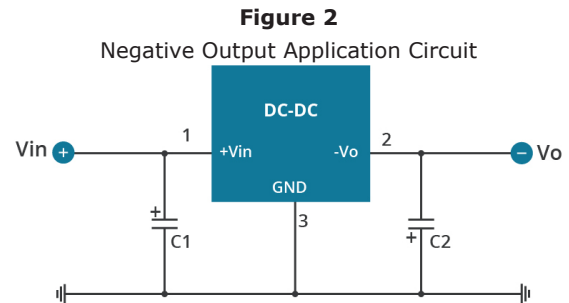
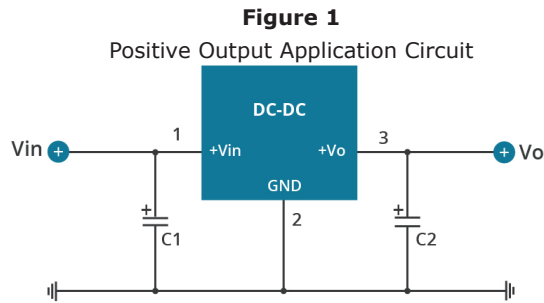

Figure 3
Positive and Negative Output Paralleling Application Circuit

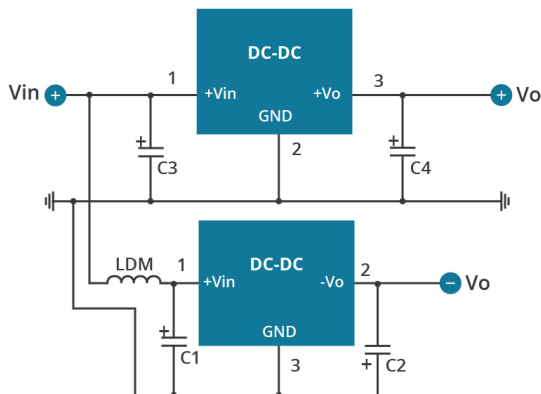

Table 1
External Capacitor Table

Model Number	C1, C3 (ceramic capacitor)	C2, C4 (ceramic capacitor)
P78E03-1000	10 μ F/50 V	22 μ F/10 V
P78E05-1000	10 μ F/50 V	22 μ F/10 V
P78E09-1000	10 μ F/50 V	22 μ F/16 V
P78E12-1000	10 μ F/50 V	22 μ F/25 V
P78E15-1000	10 μ F/50 V	22 μ F/25 V

EMC RECOMMENDED CIRCUIT

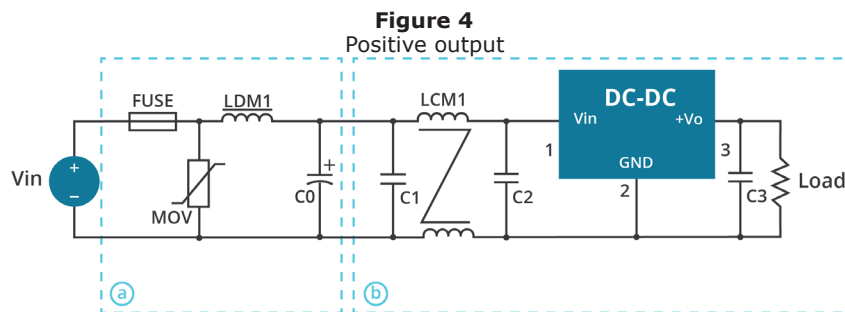

Table 2
Recommended external circuit components

Component	Value
FUSE	choose according to actual input current
MOV	20D470K
LDM1	82 μ H
C0	680 μ F/50 V
LCM1	4.7 mH
C1, C2	4.7 μ F/50 V
C3	10 μ F/50 V

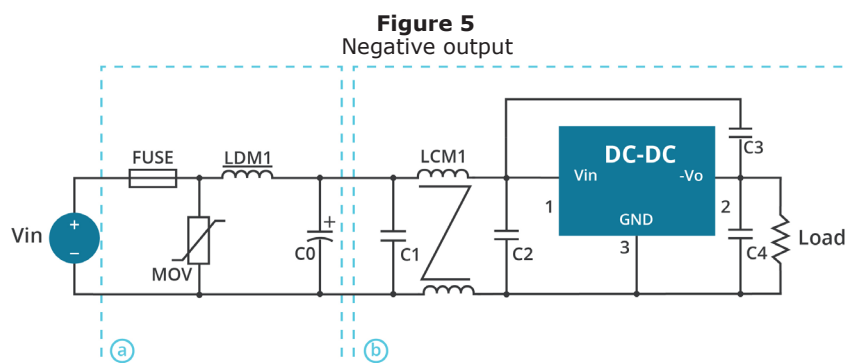

Table 3
Recommended external circuit components

Component	Value
FUSE	choose according to actual input current
MOV	20D470K
LDM1	82 μ H
C0	680 μ F/50 V
LCM1	4.7 mH
C1, C3, C4	4.7 μ F/50 V
C2	10 μ F/50 V

Note:
 7. C1 & C2 (C3 & C4) are required and should be connected as close to the module pins as possible.
 8. To reduce the output ripple further, C2 & C4 can be increased as needed and the use of tantalum or low ESR electrolytic capacitors would be recommended.
 9. When using application circuit in Figure 3, a 10 μ H LDM component is recommended to reduce the interference.

REVISION HISTORY

rev.	description	date
1.0	initial release	09/12/2018
1.01	features and safety line updated, packaging removed	01/14/2021
1.02	derating curves, efficiency curves and circuit figures updated	09/20/2021
1.03	CE removed	11/04/2022
1.04	application circuit updated	03/22/2023

The revision history provided is for informational purposes only and is believed to be accurate.



CUI INC

a bel group

Headquarters
20050 SW 112th Ave.
Tualatin, OR 97062
800.275.4899

Fax 503.612.2383
cui.com
techsupport@cui.com

CUI offers a two (2) year limited warranty. Complete warranty information is listed on our website.

CUI reserves the right to make changes to the product at any time without notice. Information provided by CUI is believed to be accurate and reliable. However, no responsibility is assumed by CUI for its use, nor for any infringements of patents or other rights of third parties which may result from its use.

CUI products are not authorized or warranted for use as critical components in equipment that requires an extremely high level of reliability. A critical component is any component of a life support device or system whose failure to perform can be reasonably expected to cause the failure of the life support device or system, or to affect its safety or effectiveness.

Looking for pricing, stock, or lifecycle information?

Click below to explore more details on WIN SOURCE:

 [View P78E03-1000 on WIN SOURCE](#)

 [CUI Inc. Information](#)

Optimize Your Supply Chain with WIN SOURCE Solutions

-  Global Sourcing Solution
-  Obsolete Management
-  Cost Control Management
-  Shortage Management
-  Alternative Solution
-  Excess Inventory Management