

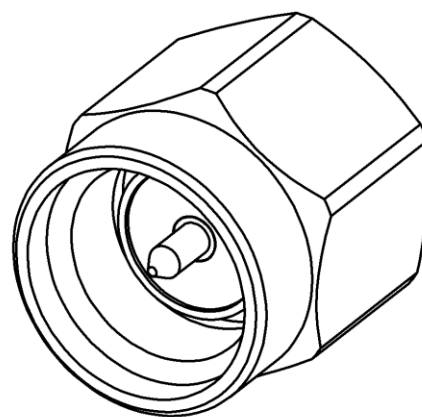

**THE DATASHEET OF
R404N01000**

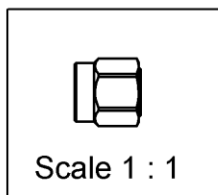

PAGE 1/2	ISSUE 16-11-18B	SERIES TERMINATION	PART NUMBER R404N01000
----------	-----------------	------------------------------	-------------------------------

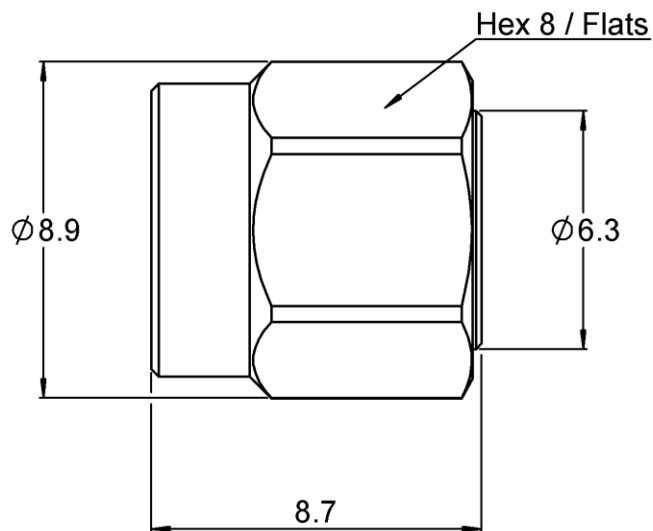

All dimensions are in mm. Tolerances according ISO 2768 m-H

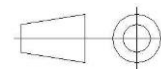

COMPONENTS	MATERIALS	PLATING (µm)
Body	STAINLESS STEEL	PASSIVATED
Center contact	BRASS	GOLD OVER NICKEL
Outer contact	STAINLESS STEEL	GOLD OVER NICKEL
Insulator	PTFE	
Gasket	SILICONE RUBBER	
Substrate	ALUMINA CERAMIC	
Resistor	THICK FILM	
Others parts		

PAGE 2/2	ISSUE 16-11-18B	SERIES TERMINATION	PART NUMBER R404N01000
----------	------------------------	------------------------------	-------------------------------

ELECTRICAL CHARACTERISTICS

Frequency (GHz)	DC - 8	8 - 12.4	12.4 - 18
V.S.W.R (≤)	1.10	1.15	1.20

Operating Frequency Range	DC - 18	GHz
Impedance	50	Ω
DC Resistance	50	Ω ± 5%
Peak power at 25°C (1μs, 1%)	100	W
Average power at 25°C	2 (1)	W (Free Air Cooled)
		W (Conduction Cooled)

MECHANICAL CHARACTERISTICS

Connectors	SMA	Male	MIL C 39012 (2)
Weight	2,200 g		

ENVIRONMENTAL CHARACTERISTICS

Operating temperature range	-55/+125	°C
Storage temperature range	-55/+125	°C

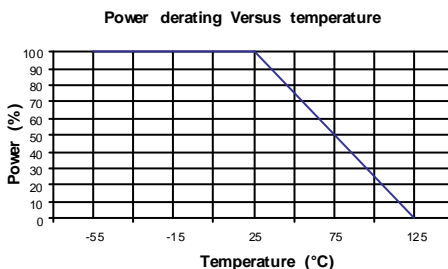

SPECIFICATION

OTHER CHARACTERISTICS

IP67 in mated conditions

Notes:

- (1) Compliant with endurance requirement per MIL DTL 39030
- (2) Insertion force of the female contact on the mating connector significantly exceeding the specifications of MIL C 39012 (13.2 N max with specified test gauge) could result in the permanent deterioration of the ceramic element of the termination and affect the center pin retention.







Looking for pricing, stock, or lifecycle information?

Click below to explore more details on WIN SOURCE:

 [View R404N01000 on WIN SOURCE](#)

 [Radiall USA, Inc. Information](#)

Optimize Your Supply Chain with WIN SOURCE Solutions

-  Global Sourcing Solution
-  Obsolete Management
-  Cost Control Management
-  Shortage Management
-  Alternative Solution
-  Excess Inventory Management