



**THE DATASHEET OF
SF2921-61345-1S**



PRODUCT DATA DRAWING

REVISION HISTORY			
REV	DESCRIPTION	DATE	APPROVED
01	PRELIMINARY	12/16	DAL

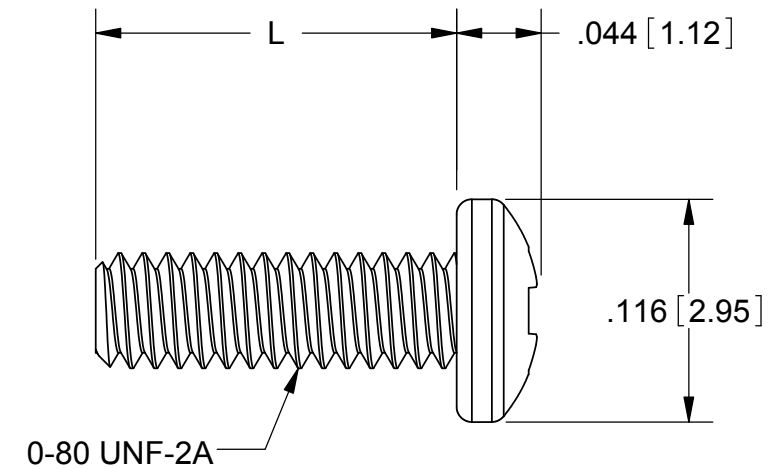
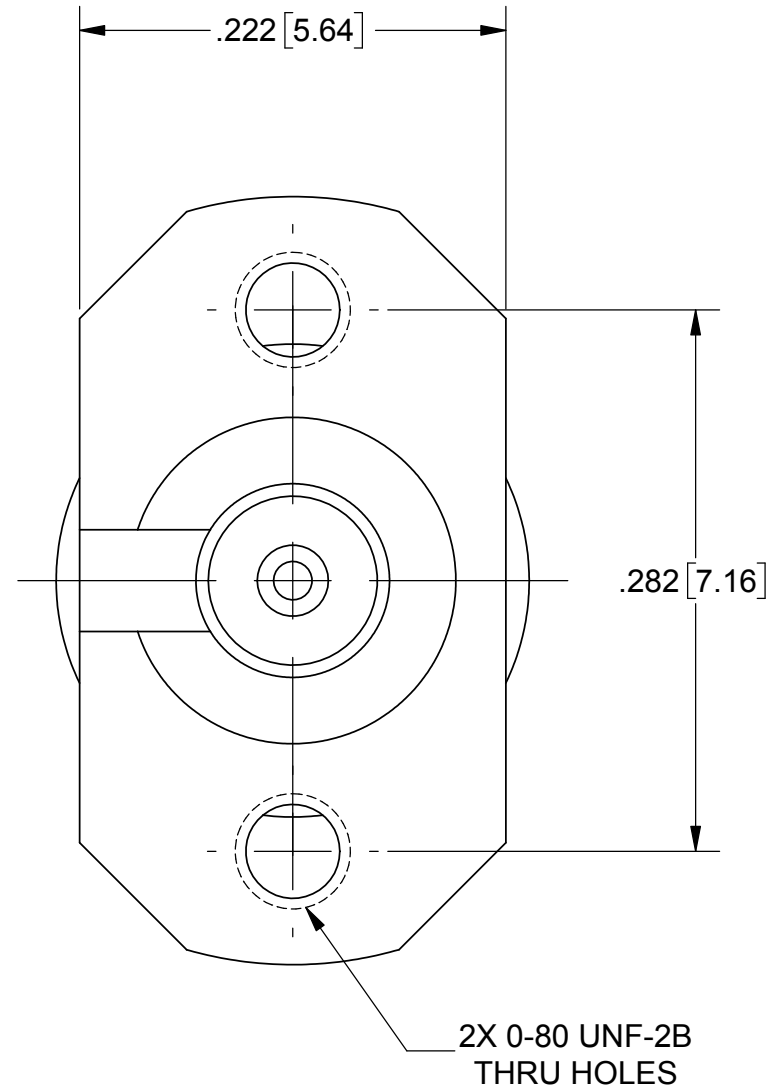
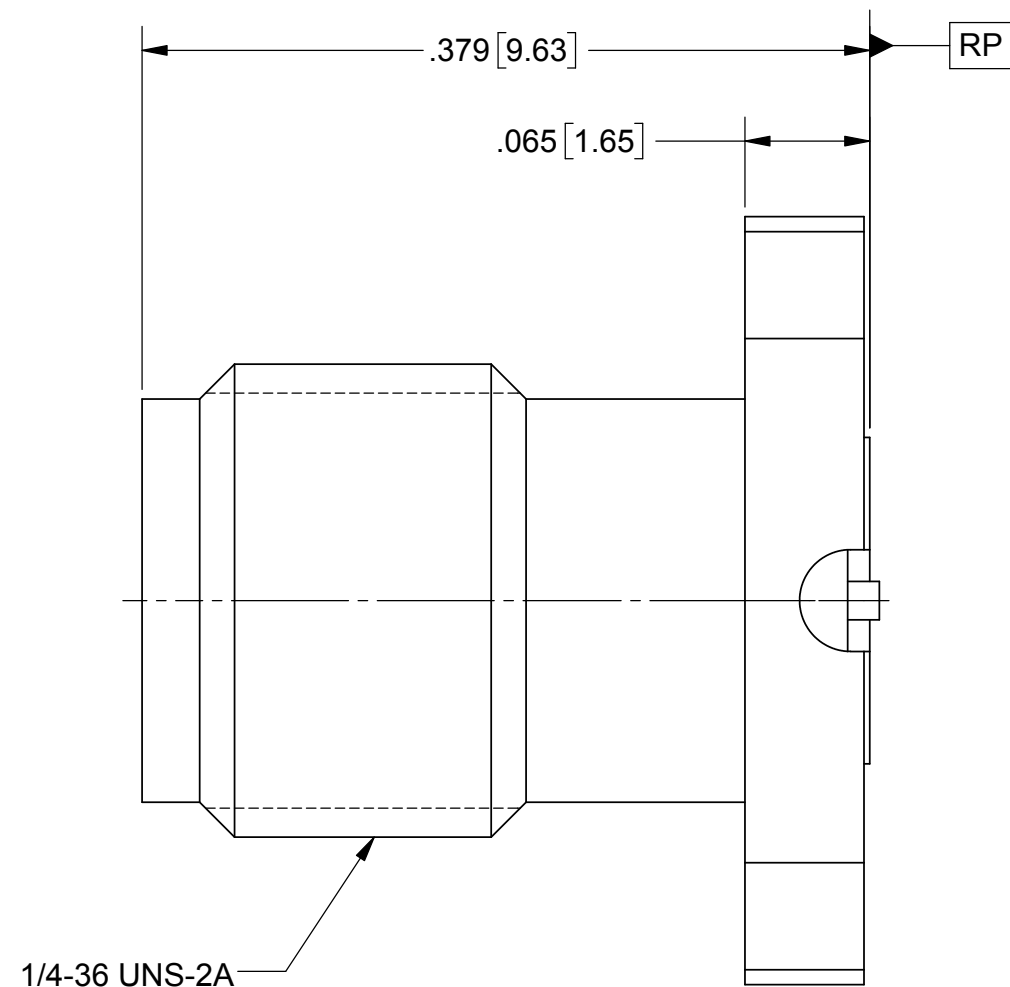

SCREW OPTIONS	L
FOR -1S	.188
FOR -2S	.250
FOR -3S	.438

SV P/N	DESCRIPTION	PCB THICKNESS
SF2921-61345-1S	INCL. TWO .188 SCREWS	.023 TO .123
SF2921-61345-2S	INCL. TWO .250 SCREWS	.085 TO .185
SF2921-61345-3S	INCL. TWO .438 SCREWS	.273 TO .373
SF2921-61345	NO SCREWS	.023 TO .373

MATERIAL:

BODY & SCREWS: STAINLESS STEEL
 CONTACT: BERYLLIUM COPPER
 INSULATOR: PTFE
FINISH:
 BODY & SCREWS: PASSIVATED
 CONTACT: GOLD OVER NICKEL

NOTES:

- FOR A FOOTPRINT RECOMMENDATION SPECIFIC TO YOUR PCB, PLEASE CONTACT US AT applications@svmicro.com

MATERIAL: SEE NOTES	DIMENSIONS ARE IN INCHES TOLERANCES: FRACTIONAL: ±1/64 ANGULAR: X° ±1'0" X'X' ±15'	UNLESS OTHERWISE SPECIFIED 1) ALL DIMENSIONS ARE IN INCHES (MILLIMETERS) 2) ALL DIMENSIONS ARE AFTER PLATING. 3) BREAK CORNERS & EDGES .005 R. MAX. 4) CHAM. 1ST & LAST THREADS. 5) SURFACE ROUGHNESS 63-MIL-STD-10. 6) DIA. 'S' ON COMMON CENTERS TO BE CONCENTRIC WITHIN T.I.R. 7) REMOVE ALL BURRS	 Amphenol 2400 Centrepark West Drive, Suite 100 West Palm Beach, FL 33409 TITLE: SMA JACK 2 HOLE FLANGE WITH MOUNTING SCREWS
FINISH: SEE NOTES	DECIMAL: X ±.030 .XX ±.010 .XXX ±.005	INTERPRET DIMENSIONS AND TOLERANCES PER ASME Y14.5M - 1994	
SURFACE AREA: N/A	THIRD ANGLE PROJECTION	DRAWN: BNK 12/08/16	SIZE: B CAGE CODE: 95077 DWG. NO. SF2921-61345-XS
PROPRIETARY THE INFORMATION CONTAINED IN THIS DRAWING IS THE SOLE PROPERTY OF SV MICROWAVE, INC. ANY REPRODUCTION IN PART OR AS A WHOLE WITHOUT THE WRITTEN PERMISSION OF SV MICROWAVE, INC IS PROHIBITED.		CHECKED: DAL 12/08/16	SCALE: 10:1
		APPROVED: DAL 12/08/16	SHEET 1 OF 1

Looking for pricing, stock, or lifecycle information?

Click below to explore more details on WIN SOURCE:

 [View SF2921-61345-1S on WIN SOURCE](#)

 [Amphenol Information](#)

Optimize Your Supply Chain with WIN SOURCE Solutions

-  Global Sourcing Solution
-  Obsolete Management
-  Cost Control Management
-  Shortage Management
-  Alternative Solution
-  Excess Inventory Management