



**THE DATASHEET OF
DTC314TKT146**



Digital transistors (built-in resistor)

DTC314TU / DTC314TK

●Features

In addition to the features of regular digital transistors,

- 1) Low saturation voltage, typically $V_{CE(sat)}=40\text{mV}$ at $I_C/I_B=50\text{mA}/2.5\text{mA}$, makes these transistors ideal for muting circuits.
- 2) These transistors can be used at high current levels, $I_C=600\text{mA}$.

●Structure

NPN digital transistor
(Built-in resistor type)

●Equivalent circuit

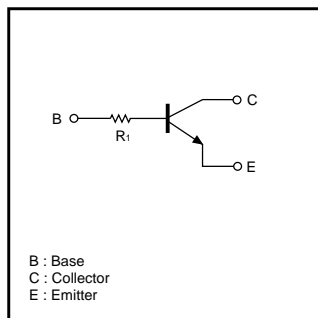

●External dimensions (Units : mm)

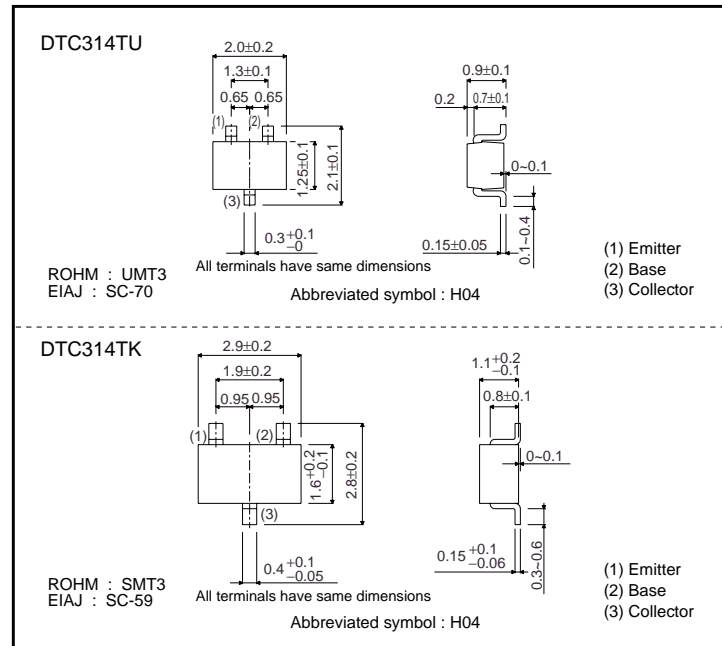

●Absolute maximum ratings (Ta=25°C)

Parameter	Symbol	Limits(DTC314T□)		Unit
		U	K	
Collector-base voltage	V_{CBO}	30		V
Collector-emitter voltage	V_{CEO}	15		V
Emitter-base voltage	V_{EBO}	5		V
Collector current	I_C	600		mA
Collector power dissipation	P_C	200		mW
Junction temperature	T_j	150		°C
Storage temperature	T_{stg}	-55~+150		°C

Transistors

●Electrical characteristics (Ta=25°C)

Parameter	Symbol	Min.	Typ.	Max.	Unit	Conditions
Collector-base breakdown voltage	BV _{CBO}	30	–	–	V	I _c =50μA
Collector-emitter breakdown voltage	BV _{CEO}	15	–	–	V	I _c =1mA
Emitter-base breakdown voltage	BV _{EBO}	5	–	–	V	I _E =50μA
Collector cutoff current	I _{CBO}	–	–	0.5	μA	V _{CB} =20V
Emitter cutoff current	I _{EBO}	–	–	0.5	μA	V _{EB} =4V
Collector-emitter saturation voltage	V _{CE(sat)}	–	40	80	mV	I _c /I _B =50mA/2.5mA
DC current transfer ratio	h _{FE}	100	250	600	–	V _{CE} =5V, I _c =50mA
Input resistance	R _i	7	10	13	kΩ	–
Transition frequency	f _T	–	200	–	MHz	V _{CE} =10V, I _E =–50mA, f=100MHz *
Output "ON" resistance	R _{on}	–	1.5	–	Ω	V _i =7V, R _L =1kΩ, f=1kHz

* Transition frequency of the device

●Packaging specifications

Type	Package	UMT3	SMT3
	Packaging type	Taping	Taping
	Code	T106	T146
	Basic ordering unit (pieces)	3000	3000
DTC314TU		○	–
DTC314TK		–	○

●Electrical characteristic curves

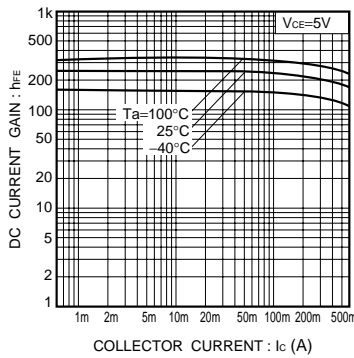

Fig.1 DC current gain vs. collector current

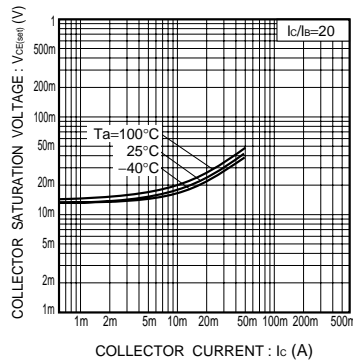

Fig.2 Collector-emitter saturation voltage vs. collector current

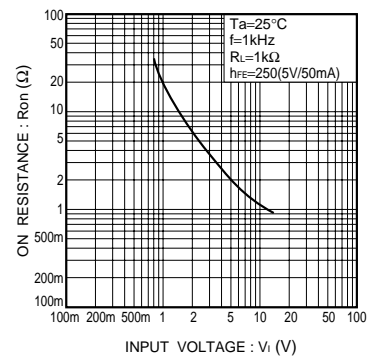

Fig.3 "ON" resistance vs. input voltage

Transistors



● R_{on} measurement circuit

Fig.4 Output "ON" resistance (R_{on}) measurement circuit

Looking for pricing, stock, or lifecycle information?

Click below to explore more details on WIN SOURCE:

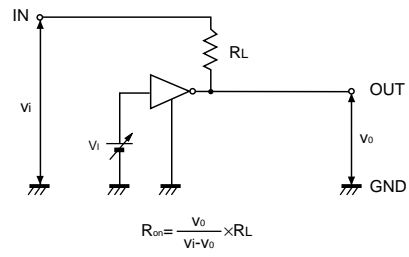
-  [View DTC314TKT146](#) on WIN SOURCE
-  [Rohm Semiconductor](#) Information

Optimize Your Supply Chain with WIN SOURCE Solutions

-  Global Sourcing Solution
-  Obsolete Management
-  Cost Control Management
-  Shortage Management
-  Alternative Solution
-  Excess Inventory Management