



**THE DATASHEET OF  
1882-00CDU**



**DESCRIPTION**

The LX1882 is a two-stage boost regulator featuring a charge pump doubler with an integrated low dropout linear regulator.

The first stage features an internal doubler charge pump converting an input supply of 1.8V to 4.4V, while the second stage is an LDO regulating the boosted voltage converting it to a regulated output.

The LX1882 is capable of supplying up to 50mA of output current with an

operating current of less than 150µA. Quiescent current is reduced to < 5µA in shutdown mode.

The LX1882's internal regulator is stable with either Tantalum or Ceramic low-value capacitors, typically 2.2µF on the output, allowing designers flexibility in external component selection.

Reliability and safety features include Thermal Shutdown Protection and Integrated Short-Circuit Protection.

**KEY FEATURES**

- Wide Input Voltage: 1.8V to 4.4V
- 3.3V and Adjustable (2.5V to 5.5V) Output Voltage Options
- Inductor-less design using small ceramic capacitors
- Low Shutdown Current of 1µA
- Internal Thermal Shutdown and Current Limiting
- 550kHz Switching Operation

**APPLICATIONS/BENEFITS**

- Cellular Telephone VCO Supplies
- Medical Instrumentation
- Data Acquisition
- Wireless PCMCIA Applications
- EMI Sensitive Boost Applications

**IMPORTANT:** For the most current data, consult MICROSEMI's website: <http://www.microsemi.com>

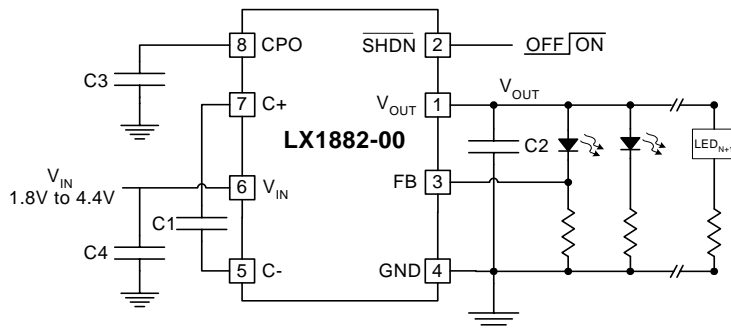
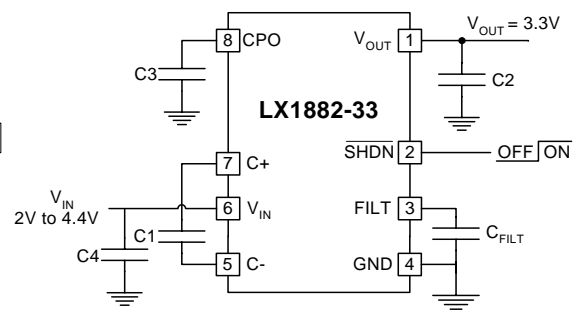
**PRODUCT HIGHLIGHT**

**LX1882: Adjustable Output; LED Driver**

**LX1882: Fixed 3.3V Output**
**PACKAGE ORDER INFO**

T <sub>J</sub> (°C)	INPUT	OUTPUT	DM	Plastic SOIC 8-PIN	DU	Plastic MSOP 8-PIN
			RoHS Compliant / Pb-free Transition DC: 0440		RoHS Compliant / Pb-free Transition DC: 0432	
0 to 70	1.8V – 4.4V	Adj	<b>LX1882-00CDM</b>		<b>LX1882-00CDU</b>	
	2V – 4.4V	3.3V	<b>LX1882-33CDM</b>		<b>LX1882-33CDU</b>	

Note: Available in Tape & Reel. Append the letters "TR" to the part number. (i.e. LX1882-00CDU-TR)

**ABSOLUTE MAXIMUM RATINGS**

$V_{IN}$ to GND .....	-0.3V to 5V
$V_{OUT}$ Voltage.....	-0.3V to 6V
CPO to Ground.....	10V
$\overline{SHDN}$ , $FILT$ , $FB$ Voltage to Ground.....	-0.3V to ( $V_{IN} + 0.3V$ )
$V_{OUT}$ Short-Circuit Duration.....	Indefinite
$I_{OUT}$ .....	90mA
Operating Temperature Range	
Commercial .....	0°C to 70°C
Storage Temperature .....	-65°C to 150°C
Maximum Junction Temperature .....	125°C
Pb-free / RoHS Peak package Solder Reflow Temp. (40 second max. exposure).....	260°C (+0, -5)

Note: Exceeding these ratings could cause damage to the device. All voltages are with respect to Ground. Currents are positive into, negative out of specified terminal.

**THERMAL DATA**
**DM Plastic 8-Pin SOIC**

<b>THERMAL RESISTANCE-JUNCTION TO AMBIENT, <math>\theta_{JA}</math></b>	<b>163°C/W</b>
<b>THERMAL RESISTANCE-JUNCTION TO CASE, <math>\theta_{JC}</math></b>	<b>38°C/W</b>

**DU Plastic 8-Pin MSOP**

<b>THERMAL RESISTANCE-JUNCTION TO AMBIENT, <math>\theta_{JA}</math></b>	<b>206°C/W</b>
<b>THERMAL RESISTANCE-JUNCTION TO CASE, <math>\theta_{JC}</math></b>	<b>39°C/W</b>

Junction Temperature Calculation:  $T_J = T_A + (P_D \times \theta_{JA})$ .

The  $\theta_{JA}$  numbers are guidelines for the thermal performance of the device/pc-board system. All of the above assume no ambient airflow.

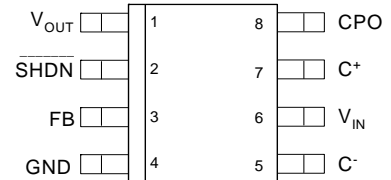
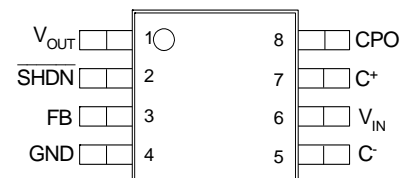
**PACKAGE PIN OUT**

**DM PACKAGE**  
(Top View)

**DU PACKAGE**  
(Top View)

RoHS / Pb-free 100% Matte Tin Lead Finish

**FUNCTIONAL PIN DESCRIPTION**

PIN NAME	PIN #	DESCRIPTION
$V_{OUT}$	1	Regulated Output Voltage. It is recommended to bypass $V_{OUT}$ with a low ESR capacitor ( $> 2\mu F$ ) placed as close to the pin as possible for best performance. For the adjustable version, the output voltage range is 2.5V to 5.5V.
$\overline{SHDN}$	2	Shutdown Pin. The LX1882 is in shutdown mode when a logic low is applied to this pin. Inversely, a logic high applied to this pin enables the device. When in shutdown mode, the charge pump output is disconnected from $V_{IN}$ (CPO will be high impedance) and $V_{OUT}$ is connected to ground through an internal 100 $\Omega$ switch.
FB	3	Adjustable Version Only. The output voltage can be set by two resistors with the following relationship: $V_{OUT} = FB * (1 + (R_1/R_2))$ where $R_1$ is the resistor connected between $V_{OUT}$ and FB, and $R_2$ is the resistor connected between FB and GND (see figure 3 on page 6).
FILT	3	Fixed Version Only. Filter pin for internal voltage reference. Typically a 1nF capacitor is connected from FILT to GND.
GND	4	System Ground.
C <sup>-</sup>	5	Flying Capacitor Negative Input.
$V_{IN}$	6	Input Voltage. The input voltage range is 1.8V to 4.4V for the LX1882-00 and 2V to 4.4V for the LX1882-33. $V_{IN}$ should be bypassed with a $> 2\mu F$ low ESR capacitor placed as close to the pin as possible for best performance. A minimum capacitance value of 0.1 $\mu F$ is required.
C <sup>+</sup>	7	Flying Capacitor Positive Input.
CPO	8	Charge Pump Output Voltage. CPO is approximately 1.95( $V_{IN}$ ) at low loads. CPO should be bypassed with a low ESR capacitor ( $> 2\mu F$ ).

SIMPLIFIED BLOCK DIAGRAM

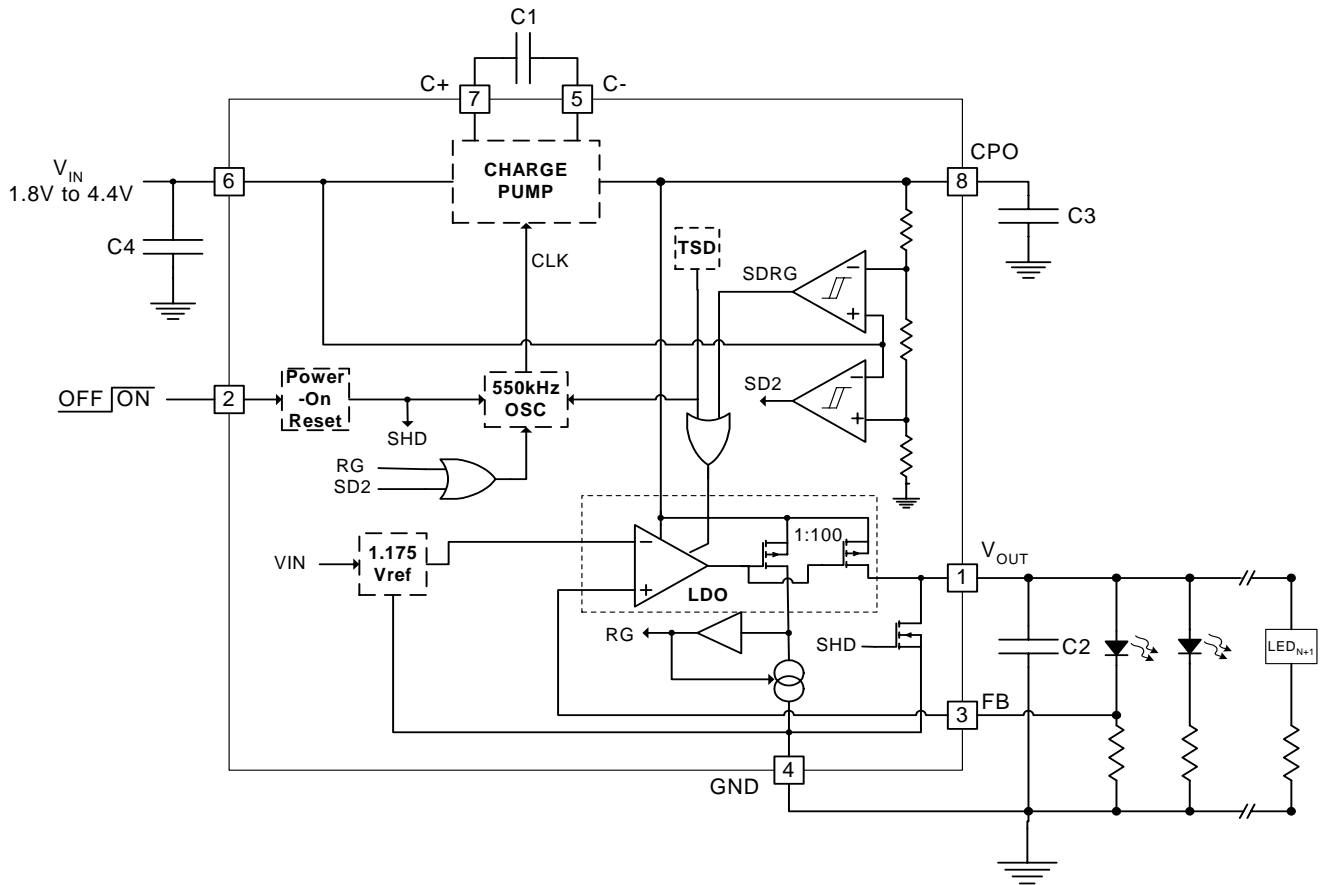

Figure 1 – LX1882-00 Block Diagram

SIMPLIFIED BLOCK DIAGRAM

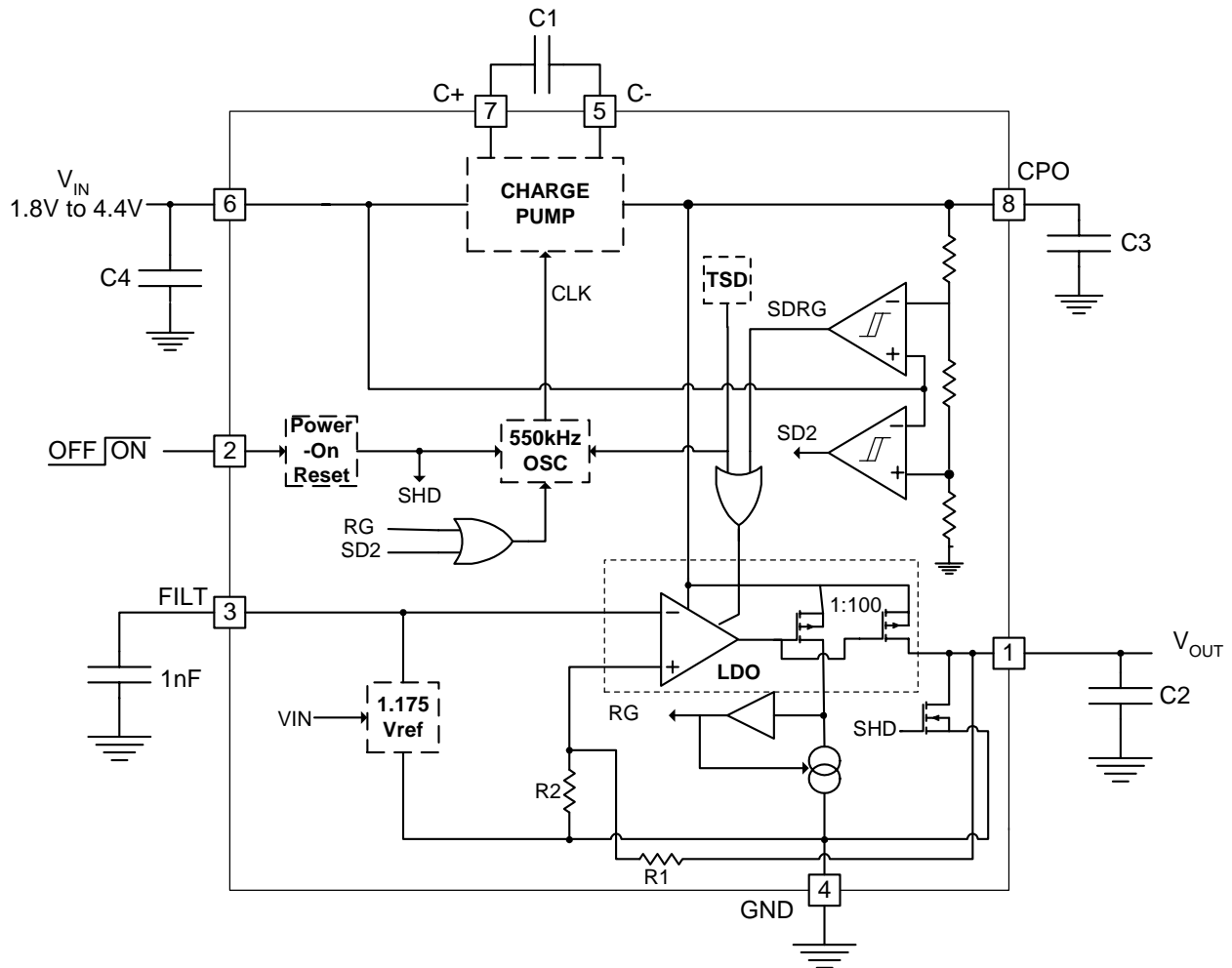

Figure 2 – LX1882-33 Block Diagram

**ELECTRICAL CHARACTERISTICS**

Unless otherwise specified, the following specifications apply over the operating ambient temperature  $0^{\circ}\text{C} \leq T_A \leq 70^{\circ}\text{C}$  except where otherwise noted. Test conditions:  $\overline{\text{SHDN}} = V_{\text{IN}} = 3\text{V}$ ,  $C_1 = 0.22\mu\text{F}$ ,  $C_2 = C_3 = C_4 = 4.7\mu\text{F}$

Parameter	Symbol	Test Conditions	LX1882-xx			Units
			Min	Typ	Max	
Operating Voltage	$V_{\text{IN}}$	LX1882-00 LX1882-33	1.8 2.0		4.4 4.4	V
$I_{\text{VIN}}$ Shutdown Current		$\overline{\text{SHDN}} = 0\text{V}$		1	5	$\mu\text{A}$
$I_{\text{VIN}}$ Operating Current		$I_{\text{OUT}} = 0\text{mA}$ , Burst Mode Operation		250	400	$\mu\text{A}$
FB Input Current		FB=1.175V	-50		50	nA
FB Voltage	$V_{\text{FB}}$	LX1882-00 only; $I_{\text{OUT}} = 1\text{mA}$	1.15	1.175	1.20	V
Regulated Output Voltage	$V_{\text{OUT}}$	LX1882-33; $I_{\text{OUT}} = 1\text{mA}$	3.23	3.30	3.37	V
$V_{\text{OUT}}$ Temperature Coefficient		$T_A = 25^{\circ}\text{C}$		$\pm 150$		ppm
Charge Pump Oscillator Frequency	$F_{\text{OSC}}$	$I_{\text{OUT}} > 200\mu\text{A}$ , $V_{\text{IN}} = 1.8\text{V}$ to $4.4\text{V}$	480	550	620	kHz
CPO (Charge Pump Output) Output Resistance	$R_{\text{CPO}}$	$V_{\text{IN}} = 1.8\text{V}$ , $I_{\text{OUT}} = 10\text{mA}$		22	30	$\Omega$
		$V_{\text{IN}} = 3\text{V}$ , $I_{\text{OUT}} = 10\text{mA}$		16	20	$\Omega$
		$V_{\text{IN}} = 4.4\text{V}$ , $I_{\text{OUT}} = 10\text{mA}$		10	20	$\Omega$
$V_{\text{OUT}}$ Dropout Voltage (Note 1)	$\Delta V$	LX1882-00; $I_{\text{OUT}} = 10\text{mA}$ , $V_{\text{OUT}} = 2.7\text{V}$ LX1882-33; $I_{\text{OUT}} = 10\text{mA}$ , $V_{\text{OUT}} = 3.3\text{V}$		100 75	160 120	mV
$V_{\text{OUT}}$ Enable Time		$I_{\text{OUT}} = 10\text{mA}$ , $T_A = 25^{\circ}\text{C}$		350		$\mu\text{s}$
$V_{\text{OUT}}$ Line Regulation	$\Delta V_{\text{OUT}}(V_{\text{IN}})$	$V_{\text{IN}} = 3\text{V}$ to $4\text{V}$ , $I_{\text{OUT}} = 0\text{mA}$		17	30	mV
$V_{\text{OUT}}$ Load Regulation	$\Delta V_{\text{OUT}}(I_{\text{OUT}})$	$I_{\text{OUT}} = 1\text{mA}$ to $10\text{mA}$		3	10	mV
		$I_{\text{OUT}} = 1\text{mA}$ to $50\text{mA}$		40		mV
$V_{\text{OUT}}$ Shutdown Resistance		$\overline{\text{SHDN}} = 0\text{V}$ , Resistance Measured to GND, $V_{\text{IN}} = 1.8\text{V}$		120	350	$\Omega$
		$\overline{\text{SHDN}} = 0\text{V}$ , Resistance Measured to GND, $V_{\text{IN}} = 4.4\text{V}$		50	150	$\Omega$
$\overline{\text{SHDN}}$ Input Threshold		$V_{\text{IN}} = 1.8\text{V}$ to $4.4\text{V}$	0.4	1	1.6	V
$\overline{\text{SHDN}}$ Input Current		$\overline{\text{SHDN}} = V_{\text{IN}}$	-1		1	$\mu\text{A}$
		$\overline{\text{SHDN}} = 0\text{V}$	-1		1	$\mu\text{A}$

Note 1: Dropout voltage is defined as the minimum input to output differential required to maintain regulation.

**APPLICATION INFORMATION**
**OPERATION**

Using a switched-capacitor charge pump, the LX1882 generates a charge pump output (CPO) voltage approximately twice the input voltage. The charge pump is a doubler configuration using one external flying capacitor. A 2-phase non-overlapping clock, generated from an internally trimmed oscillator, controls the charge pump switches to ensure maximum efficiency. CPO powers an internal low dropout (LDO) linear regulator providing a regulated output at  $V_{OUT}$ . CPO can also be used to drive an external load; refer to section on CPO Loading. The CPO voltage and  $V_{IN}$  are sensed via internal comparators for power-up conditioning. At power-up, the LDO is disabled and the load is removed from CPO. The LDO is enabled when the CPO voltage reaches  $1.75(V_{IN})$ . When the CPO voltage drops below  $1.45(V_{IN})$ , the LDO is disabled. Sensing the LX1882 output current determines the charge pump operating mode. If the output current is less than 100 $\mu$ A and the CPO voltage is greater than  $1.95(V_{IN})$ , the charge pump operates in Burst Mode. In Burst Mode, the clock is disabled for increased efficiency, until the CPO voltage droops approximately 100mV at which time the clock is enabled. To minimize noise at CPO, a low ESR capacitor of at least 2 $\mu$ F should be used.

The internal LDO can supply up to 50mA of output current and requires an output capacitor between  $V_{OUT}$  and GND to stabilize the internal control loop. A low ESR capacitor of at least 2 $\mu$ F is recommended.

**ADJUSTABLE OUTPUT VOLTAGE**

The LX1882-00 develops a 1.175 reference voltage between the FB pin and GND. The output voltage can be set using an external resistor divider (see Figure 3).

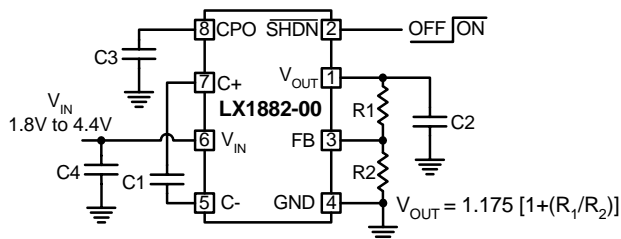

**Figure 3.** LX1882-00; Adjustable Version

The output voltage range is 2.5V to 5.5V.

**MAXIMUM  $V_{OUT}$  AND  $I_{OUT}$  CALCULATIONS**

Using the open circuit CPO voltage ( $\approx 2(V_{IN})$ ), the dropout voltage of the LDO, and the effective charge pump output resistance, the maximum available output voltage and current can be calculated.

**MAXIMUM  $V_{OUT}$  AND  $I_{OUT}$  CALCULATIONS (CONT'D)**

The maximum available output voltage can be calculated given a minimum input voltage and output current load using the following equation:

$$V_{OUT(max)} = 2(V_{IN(min)} - (I_{OUT})(R_{CPO}) - V_{DROPOUT}$$

with the condition that  $(I_{OUT})(R_{CPO}) < 0.55V_{IN}$ .

Example:

$$V_{IN(max)} = 3V$$

$$I_{OUT} = 10mA$$

$$R_{CPO(max)} = 20\Omega$$

$$\text{Unloaded CPO Voltage (max)} = 6V$$

$$\text{Loaded CPO Voltage} = 6V - (10mA)(20\Omega) = 5.8V$$

$$V_{DROPOUT} = 0.075V$$

$$V_{OUT(max)} = (6V) - (0.2) - (0.075) = 5.73$$

$$V_{OUT} < 5.5 \text{ and } (I_{OUT})(R_{CPO}) < 0.55V_{IN}, 0.2V < 1.65V$$

For minimum noise applications, keep the LDO out of dropout to prevent CPO noise from coupling into  $V_{OUT}$ .

**CAPACITOR SELECTION**

To reduce noise and ripple, it is recommended to use low ESR capacitors for C2 ( $V_{OUT}$ ), C3 (CPO), and C4 ( $V_{IN}$ ); see Figure 1. For stability purposes, C2 must be at least 2 $\mu$ F and C3 must be equal to or greater than C2. It is also recommended that C4 be at least 2 $\mu$ F. A 2.2 $\Omega$  resistor may be required between  $V_{IN}$  and the supply to reduce ripple that may be induced onto the voltage rail due to large instantaneous currents demanded by the charge pump.

A 0.22 $\mu$ F, low ESR ceramic capacitor is recommended for C1 (charge pump flying capacitor). To improve  $V_{OUT}$  ripple for light loads or for high  $V_{IN}$ , a smaller capacitor could be used for C1 to reduce ripple on CPO.

To minimize the enable time, the CPO filter capacitor (C3) should be at least 2x the  $V_{OUT}$  filter capacitor (C2). At power-up, the LDO is disabled and the load is removed from CPO. When the CPO voltage reaches  $1.75(V_{IN})$  the LDO is enabled and a large amount of charge is dumped from the CPO capacitor into the  $V_{OUT}$  capacitor. If the amount of charge dumped causes the CPO voltage to fall below  $1.45(V_{IN})$ , the LDO will be disabled and the CPO voltage will have to charge up to  $1.75(V_{IN})$  to enable the LDO. This cycle results in an extended enable time.

For the LX1882-33, a 1nF filter capacitor should be connected between the FILT pin and GND for optimum noise performance.

**CPO LOADING**

The CPO can drive an external load. Current draw by the external load will reduce the maximum available current at  $V_{OUT}$  (i.e. if CPO is driving a 5mA load, the available current from  $V_{OUT}$  will be reduced by 5mA).

## APPLICATION INFORMATION (CONTINUED)

**POWER-ON RESET**

The LX1882 contains power-on reset circuitry that insures all internal functions are correctly initialized upon power-up. Once the input voltage reaches approximately 1V, the power-on reset circuit enables the device as long as the  $\overline{\text{SHDN}}$  pin is held high.

**SHUTDOWN**

The  $\overline{\text{SHDN}}$  pin allows the LX1882 to be enabled or disabled. A logic zero (0.4V) on the  $\overline{\text{SHDN}}$  pin places the LX1882 in shutdown mode, reducing the supply current to  $< 5\mu\text{A}$  and connecting  $V_{\text{OUT}}$  to ground through a  $100\Omega$  switch. In addition, CPO will be high impedance and disconnected from  $V_{\text{IN}}$ . If the shutdown feature is not required, connect  $\overline{\text{SHDN}}$  to  $V_{\text{IN}}$  to continuously enable the part.

**Current Limit Protection**

The LX1882 includes over current protection. When the output load current exceeds typically 60mA, the circuit forces the regulator output to decrease.

**Temperature Protection**

The thermal protection shuts the LX1882 down when the junction temperature exceeds  $140^{\circ}\text{C}$ . Exposure to absolute maximum rated conditions for extended periods may affect device reliability (see Thermal Considerations below).

**THERMAL CONSIDERATIONS**

Thermal shutdown protects the circuit from thermal overload caused from a rise in junction temperature during power dissipation. This means of protection is intended for fault protection only and not as a means from current or power limiting during normal application usage. Proper thermal evaluation should be done to ensure that the junction temperature does not exceed its maximum rating ( $125^{\circ}\text{C}$ ). Due to variation in individual device electrical characteristics and thermal resistance, the built in thermal overload protection may be activated at power levels slightly above or below the rated dissipation.

**EVALUATION BOARD**

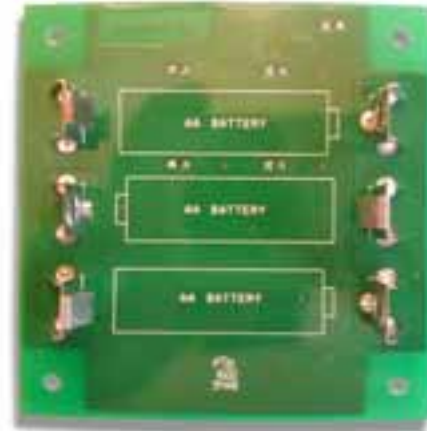
**Figure 4.** LX1882 LED Driver Evaluation Board (Top View)

**Figure 5.** LX1882 LED Driver Evaluation Board (Bottom View)

**Table 1: Input and Output Pin Assignments**

Pin Name	Description
VIN	Input Voltage Test Point. Use this pin to monitor the input voltage.
VOUT	Output Voltage Test Point. Use this pin to monitor output voltage. Output Voltage is determined using the following equation: $V_{OUT} = V_{FB} [1 + (R_1/R_2)] - V_{SET} (R_1/R_2)$ ; where $V_{SET} = I_{LED} (R_3)$ and $V_{FB} = 1.175V$ (see Figure 6).
FB	Feedback Pin Test Point. Use this pin to monitor feedback voltage. Min = 1.150V, Typical = 1.175V, Max = 1.20V.
CPO	Charge Pump Output Test Point. Use this pin to monitor the charge pump output or connect an external load to this pin for the charge pump to drive. Note: Maximum output current available is reduced by the amount of current drawn from the CPO pin.
SHDN	Shutdown Test Point. Use this pin to monitor operating status of device. Logic HIGH = enabled; Logic LOW = shutdown mode (see Table 2 below).
GND	System Ground Test Points.
External VCC	External DC Input Voltage. Apply a 1.8V to 4.4V input to this pin when switch "VCC" is set to "EXT". Clip the positive lead of the external power supply to the pin of the 2-pin header labeled "External VCC +". Clip the negative lead of the external power supply to the pin of the 2-pin header labeled "External VCC -".

**Table 2: Switch Position Assignments**

Switch Name	Functional Description
VCC EXT	Use this position when powering the board from an external power supply.
VCC BAT	Use this position when powering the board using "AA" batteries. Three "AA" batteries can be installed via battery clips located on the back of the board.
SHDN ENABLE	Use this position to enable the LX1882.
SHDN DISABLE	Use this position to disable the LX1882.

**EVALUATION BOARD (CONTINUED)**
**Table 3: Factory Installed Component List for the LX1882 Evaluation Board**

Quantity	Part Reference	Description	Manufacturer	Part Number
1	C1	Capacitor, Ceramic, 0.22uF, 16V, 10%, 0805 Type SMT	Panasonic	ECJ2VB1C224K
3	C2 - C4	Capacitor, Ceramic X5R, 4.7uF, 25V, 1210 Type SMT	Taiyo Yuden	CETMK325BJ475MN
4	D1 - 4	White LED	Chicago Miniature	CMD333UWC
3	J1 - J3	Terminal Battery Clip, Positive Button, AA Contacts	Keystone	596
3	J4 - J6	Terminal Battery Clip, Negative Button, AA Contacts	Keystone	590
1	P2	Header, 2-Pin	Molex	42375-2
1	R1	Resistor, 46.4K, 1/10W,1%, 0805 Type SMT	Panasonic	ERJ6EKF4642
1	R2	Resistor, 14.3K, 1/10W,1%, 0805 Type SMT	Panasonic	ERJ6EKF1432
4	R3 - R6	Resistor, 30.1, 1/10W,1%, 0805 Type SMT	Panasonic	ERJ6EKF30R1
1	R8	Resistor, 10.0K, 1/10W,1%, 0805 Type SMT	Panasonic	ERJ6EKF1002
2	S1, S2	Switch, SPDT, 1 position, SMT DIP Type	CTS	204-121ST
9	TP1 - TP9	Terminal, Surface Mount, Compact Style Test Point	Keystone	5016
1	U1	IC, LX1882 Charge Pump Doubler with Linear Regulator	Microsemi	LX1882-00CDM

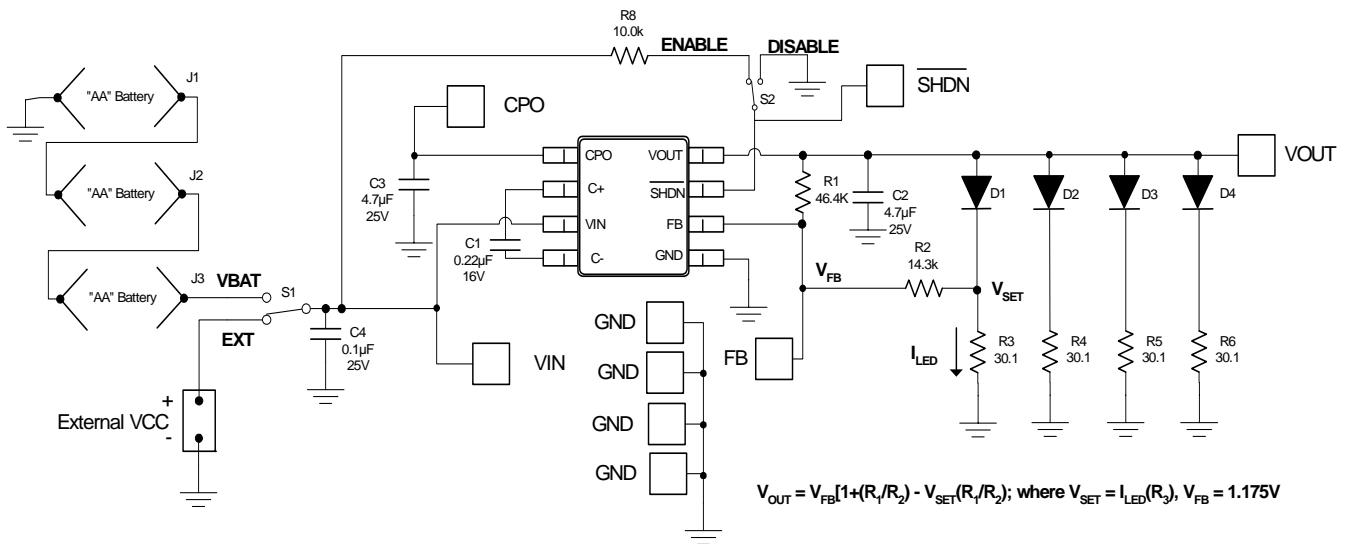
**Figure 6 – LX1882-00 Evaluation Board Schematic; LED Driver Application**

**CHARACTERISTIC CURVES**

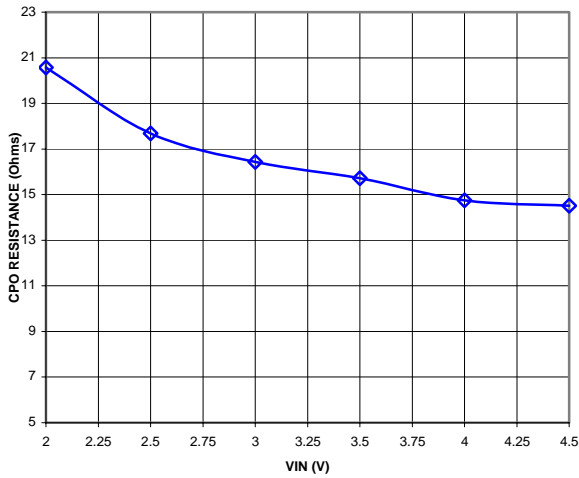

**Figure 7 – CPO Output Resistance vs. Input Voltage;**  
 $T_A = 25^\circ\text{C}$ ,  $C_1 = 0.22\mu\text{F}$ ,  $C_2, C_3, C_4 = 4.7\mu\text{F}$ ,  $C_{\text{FILT}} = 0.1\mu\text{F}$

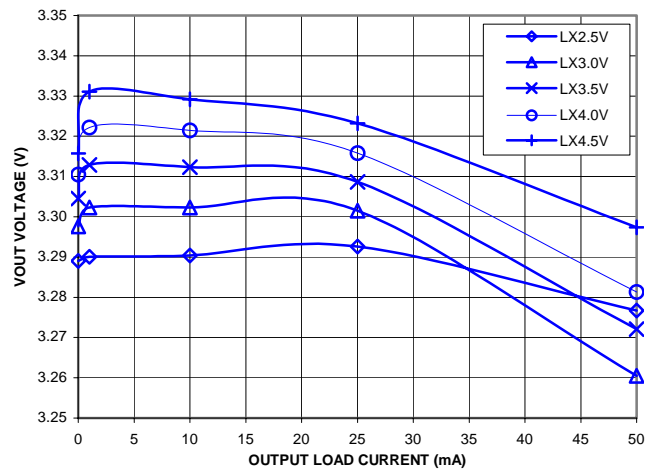

**Figure 8 – LX1882-33 Output Voltage vs. Load Current;**  
 $T_A = 25^\circ\text{C}$ ,  $C_1 = 0.22\mu\text{F}$ ,  $C_2, C_3, C_4 = 4.7\mu\text{F}$ ,  $C_{\text{FILT}} = 0.1\mu\text{F}$

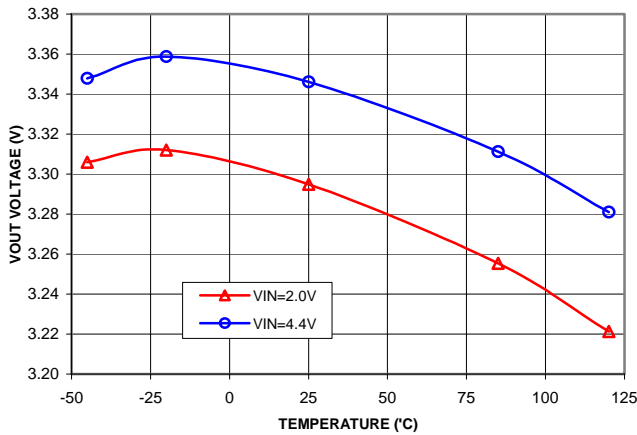

**Figure 9 – LX1882-33 Output Voltage vs. Temperature;**  
 $C_1 = 0.22\mu\text{F}$ ,  $C_2, C_3, C_4 = 4.7\mu\text{F}$ ,  $C_{\text{FILT}} = 0.1\mu\text{F}$

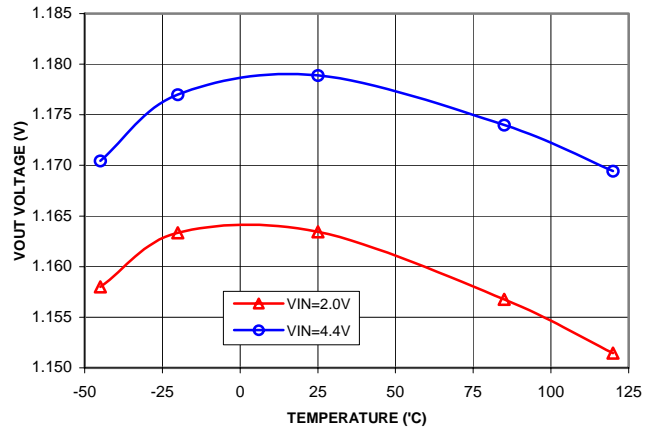

**Figure 10 – LX1882-00 Output Voltage vs. Temperature;**  
 $C_1 = 0.22\mu\text{F}$ ,  $C_2, C_3, C_4 = 4.7\mu\text{F}$

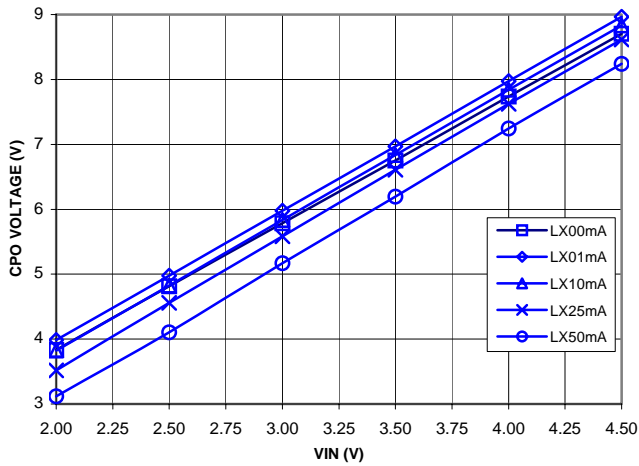
**CHARACTERISTIC CURVES**

**Figure 11 – CPO Voltage vs. Input Voltage;**  
 $T_A = 25^\circ\text{C}$ ,  $C_1 = 0.22\mu\text{F}$ ,  $C_2, C_3, C_4 = 4.7\mu\text{F}$ ,  $C_{\text{FILT}} = 0.1\mu\text{F}$

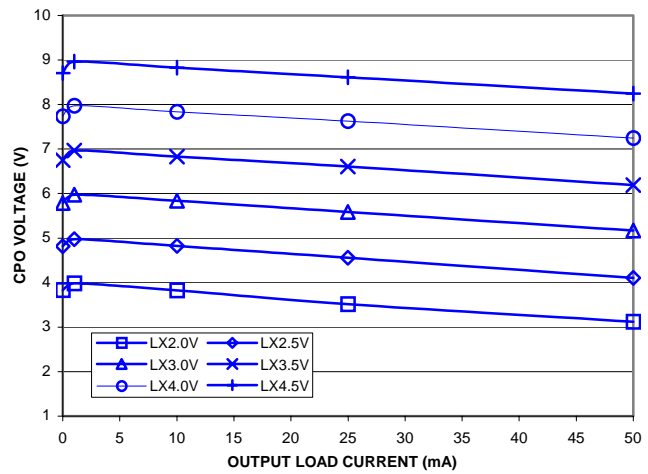

**Figure 12 – CPO Voltage vs. Load Current;**  
 $T_A = 25^\circ\text{C}$ ,  $C_1 = 0.22\mu\text{F}$ ,  $C_2, C_3, C_4 = 4.7\mu\text{F}$ ,  $C_{\text{FILT}} = 0.1\mu\text{F}$

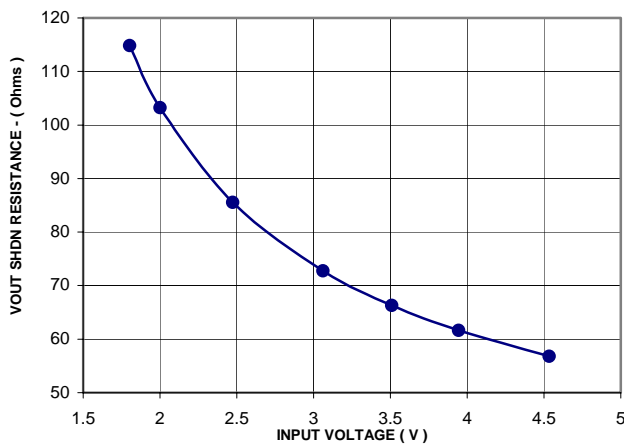

**Figure 13 –  $V_{\text{OUT}}$  Shutdown Resistance vs. Input Voltage;**  
 $T_A = 25^\circ\text{C}$ ,  $C_1 = 0.22\mu\text{F}$ ,  $C_2, C_3, C_4 = 4.7\mu\text{F}$ ,  $C_{\text{FILT}} = 0.1\mu\text{F}$

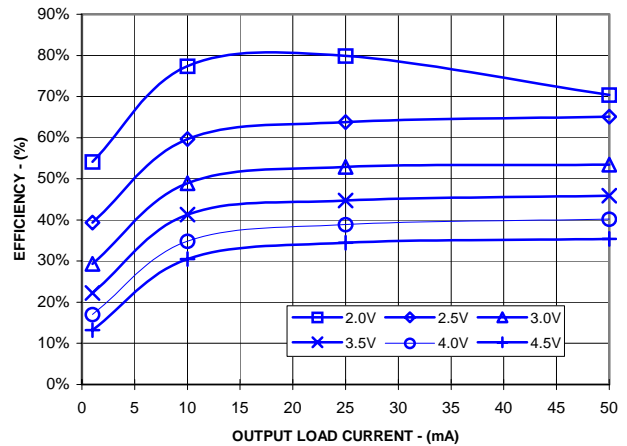

**Figure 14 – Efficiency vs. Output Current;**  
 $T_A = 25^\circ\text{C}$ ,  $C_1 = 0.22\mu\text{F}$ ,  $C_2, C_3, C_4 = 4.7\mu\text{F}$ ,  $C_{\text{FILT}} = 0.1\mu\text{F}$

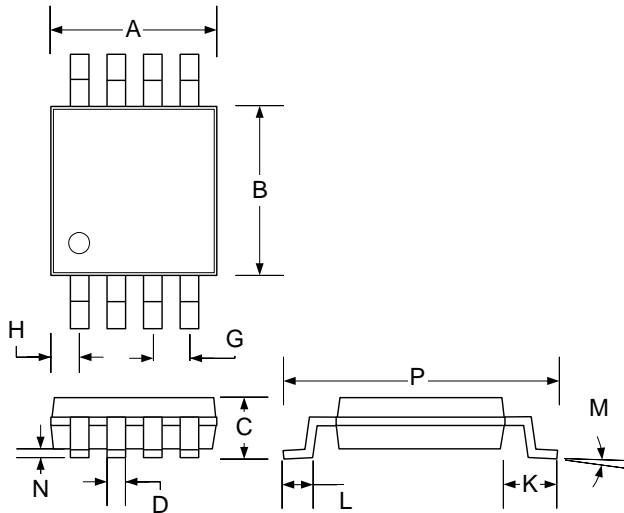
**MECHANICAL DRAWING**
**DU 8-Pin MSOP**

Dim	MILLIMETERS		INCHES	
	MIN	MAX	MIN	MAX
A	2.85	3.05	.112	.120
B	2.90	3.10	.114	.122
C	-	1.10	-	0.043
D	0.25	0.40	0.009	0.160
G	0.65 BSC		0.025 BSC	
H	0.38	0.64	0.015	0.025
J	0.13	0.18	0.005	0.007
K	0.95 BSC		0.037 BSC	
L	0.40	0.70	0.016	0.027
M	3°		3°	
N	0.05	0.15	0.002	0.006
P	4.75	5.05	0.187	0.198

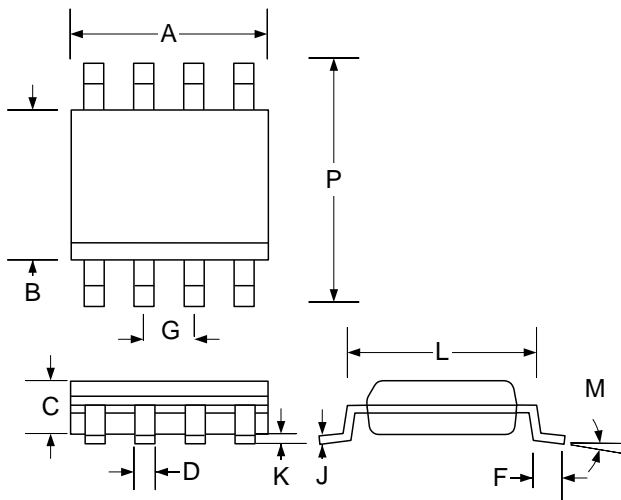
**DM 8-Pin Plastic SOIC**

Dim	MILLIMETERS		INCHES	
	MIN	MAX	MIN	MAX
A	4.83	5.00	0.190	0.197
B	3.81	3.94	0.150	0.155
C	1.35	1.75	0.053	0.069
D	0.33	0.51	0.013	0.020
F	-	0.77	-	0.030
G	1.27 BSC		0.050 BSC	
J	0.19	0.25	0.007	0.010
K	0.13	0.25	0.005	0.010
L	4.80	5.21	0.189	0.205
M	-	8°	-	8°
P	5.79	6.20	0.228	0.244
*LC	-	0.10	-	0.004

\*Lead Coplanarity

**Note:**

- Dimensions do not include mold flash or protrusions; these shall not exceed 0.155mm(.006") on any side. Lead dimension shall not include solder coverage.

**NOTES**

PRODUCTION DATA – Information contained in this document is proprietary to Microsemi and is current as of publication date. This document may not be modified in any way without the express written consent of Microsemi. Product processing does not necessarily include testing of all parameters. Microsemi reserves the right to change the configuration and performance of the product and to discontinue product at any time.

## Looking for pricing, stock, or lifecycle information?

Click below to explore more details on WIN SOURCE:

- ⊖ [View 1882-00CDU on WIN SOURCE](#)
- ⊖ [Microsemi Corporation](#) Information

## Optimize Your Supply Chain with WIN SOURCE Solutions

- ✓ Global Sourcing Solution
- ✓ Obsolete Management
- ✓ Cost Control Management
- ✓ Shortage Management
- ✓ Alternative Solution
- ✓ Excess Inventory Management