



**THE DATASHEET OF  
MAX20075ATCA/V+T**



## 36V, 600mA/1.2A Mini Buck Converter

## MAX20075/MAX20076/ MAX25276

### General Description

The MAX20075/MAX20076/MAX25276 are small, synchronous buck converters with integrated high-side and low-side switches. The MAX20076/MAX25276 are designed to deliver up to 1.2A and the MAX20075 up to 0.6A, with 3.5V to 36V input voltages. The devices provide an accurate output voltage of  $\pm 2\%$  within the normal operation input range of 6V to 18V. With 20ns minimum on-time capability, the converter is capable of large input-to-output conversion ratios. Voltage quality can be monitored by observing the PGOOD signal. The devices can operate in dropout by running at 99% duty cycle, making them ideal for automotive and industrial applications. The devices offer two fixed output voltages of 5V and 3.3V. In addition, the devices can be configured for 1V to 10V output voltages using an external resistor-divider. Frequency is internally fixed at 2.1MHz, which allows for small external components and reduced output ripple, and guarantees no AM interference. The devices offer pin-enabled spread-spectrum-frequency modulation designed to minimize EMI-radiated emissions due to the modulation frequency.

The MAX20075/MAX20076/MAX25276 are available in small (3mm x 3mm) 12-pin TDFN and side-wettable TDFN packages with an exposed pad, and use very few external components.

### Applications

- Automotive
- Industrial
- High-Voltage DC-DC Converters

**Ordering Information** appears at end of data sheet.

### Benefits and Features

- Synchronous DC-DC Converter with Integrated FETs
  - MAX20075 = 0.6A  $I_{OUT}$
  - MAX20076/MAX25276 = 1.2A  $I_{OUT}$
  - For applications requiring low quiescent current/skip mode operation, please refer to MAX20075D/MAX20076D/MAX25276D. This device is only recommended for FPWM operation.
- 20ns Minimum On-Time Small Solution Size Saves Space
  - 2.1MHz Frequency
  - Programmable 1V to 10V Output for the Buck, or Fixed 5V/3.3V Options Available
  - Fixed 2.5ms Internal Soft-Start
  - Fixed Output Voltage with  $\pm 2\%$  Output Accuracy (5V/3.3V), or Externally Resistor Adjustable (1V to 10V) with  $\pm 1.5\%$  FB Accuracy
  - Innovative Current-Mode-Control Architecture Minimizes Total Board Space and BOM Count
- PGOOD Output and High-Voltage EN Input Simplify Power Sequencing
- Protection Features and Operating Range Ideal for Automotive Applications
  - 3.5V to 36V Operating  $V_{IN}$  Range
  - 40V Load-Dump Protection
  - 99% Duty-Cycle Operation with Low Dropout
  - $-40^{\circ}\text{C}$  to  $+125^{\circ}\text{C}$  Automotive Temperature Range
  - AEC-Q100 Qualified

### Simplified Block Diagram

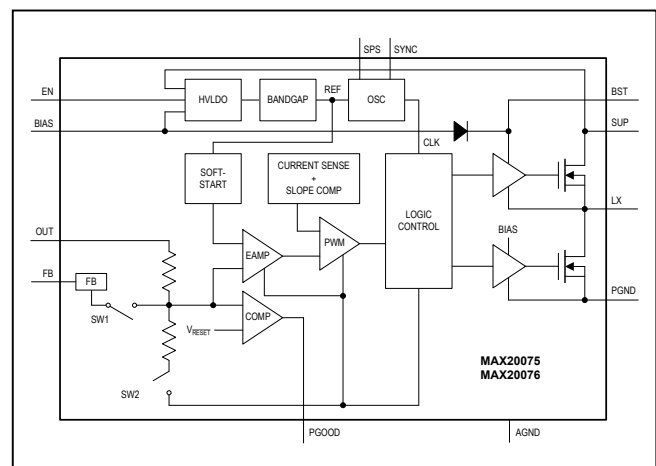

19-8730; Rev 12; 11/21

**Absolute Maximum Ratings**

SUP .....	-0.3V to +40V	OUT Short-Circuit Duration .....	Continuous
EN.....	-0.3V to $V_{SUP} + 0.3V$	ESD Protection .....	
BST to LX (Note 1).....	+6V	Human Body Model .....	±2kV
BST.....	-0.3V to +45V	Continuous Power Dissipation ( $T_A = +70^{\circ}C$ )	
FB .....	-0.3V to $V_{BIAS} + 0.3V$	12-pin TDFN/SW TDFN	
SYNC.....	-0.3V to $V_{BIAS} + 0.3V$	(derate 24.4mW/ $^{\circ}C$ above +70 $^{\circ}C$ ) .....	1951mW
SPS .....	-0.3V to $V_{BIAS} + 0.3V$	Operating Junction Temperature (Note 5).....	-40 $^{\circ}C$ to +150 $^{\circ}C$
OUT .....	-0.3V to +18V	Storage Temperature Range .....	-65 $^{\circ}C$ to +150 $^{\circ}C$
PGOOD .....	-0.3V to +6V	Junction Temperature.....	+150 $^{\circ}C$
PGND to AGND.....	-0.3V to +0.3V	Lead Temperature (Soldering, 10s).....	+300 $^{\circ}C$
BIAS .....	-0.3V to +6.0V	Soldering Temperature (Reflow).....	+260 $^{\circ}C$

Stresses beyond those listed under "Absolute Maximum Ratings" may cause permanent damage to the device. These are stress ratings only, and functional operation of the device at these or any other conditions beyond those indicated in the operational sections of the specifications is not implied. Exposure to absolute maximum rating conditions for extended periods may affect device reliability.

**Note 1:** LX has internal clamp diodes to PGND/AGND and SUP. Applications that forward bias these diodes should take care not to exceed the IC's package power-dissipation limits.

**Recommended Operating Conditions**

Parameter	Ambient temperature range
Conditions	-40 $^{\circ}C$ to +125 $^{\circ}C$

**Package Information**

<b>PACKAGE TYPE: 12 TDFN-CU</b>	
Package Code	TD1233+2C
Outline Number	<a href="#">21-0664</a>
Land Pattern Number	<a href="#">90-0397</a>
<b>PACKAGE TYPE: 12 SW TDFN</b>	
Package Code	TD1233Y+2C
Outline Number	<a href="#">21-100176</a>
Land Pattern Number	<a href="#">90-100072</a>
<b>PACKAGE TYPE: 12 SW TDFN</b>	
Package Code	TD1233Y+3C
Outline Number	<a href="#">21-100284</a>
Land Pattern Number	<a href="#">90-100072</a>
<b>THERMAL RESISTANCE, FOUR-LAYER BOARD</b>	
Junction to Ambient ( $\theta_{JA}$ )	41 $^{\circ}C/W$
Junction to Case ( $\theta_{JC}$ )	9 $^{\circ}C/W$

For the latest package outline information and land patterns (footprints), go to [www.maximintegrated.com/packages](http://www.maximintegrated.com/packages). Note that a "+", "#", or "-" in the package code indicates RoHS status only. Package drawings may show a different suffix character, but the drawing pertains to the package regardless of RoHS status.

Package thermal resistances were obtained using the method described in JEDEC specification JESD51-7, using a 4-layer board. For detailed information on package thermal considerations, refer to [www.maximintegrated.com/thermal-tutorial](http://www.maximintegrated.com/thermal-tutorial).

**Electrical Characteristics**

(V<sub>SUP</sub> = V<sub>EN</sub>, V<sub>SUP</sub> = 14V, V<sub>SYNC</sub> = 5V, V<sub>OUT</sub> = 5V, T<sub>J</sub> = -40°C to +150°C, unless otherwise noted.) (Notes 4, 5)

PARAMETER	SYMBOL	CONDITIONS	MIN	TYP	MAX	UNITS
Supply Voltage Range	V <sub>SUP</sub>		3.5		36	V
		t < 1s			40	
		MAX25276, after startup (Note 2)	3		36	
LX Leakage	I <sub>LX,LEAK</sub>	V <sub>SUP</sub> = 40V, LX = 0 or 40V, T <sub>A</sub> = +25°C	-1		+1	μA
Undervoltage Lockout	UVLO	OUT rising	2.52	2.73	2.93	V
		Hysteresis		0.16		
BIAS Voltage	V <sub>BIAS</sub>	5.5V ≤ V <sub>SUP</sub> ≤ 36V, FPWM mode		5		V
<b>BUCK CONVERTER</b>						
Voltage Accuracy, 5V	V <sub>OUT,5V</sub>	MAX20075/76ATCA/V+ fixed-frequency PWM mode	4.93	5	5.07	V
Voltage Accuracy, 5.147V	V <sub>OUT,5.147V</sub> (Note 2)	MAX25276ATCA/VY+ fixed frequency PWM mode	5.070	5.147	5.224	V
Voltage Accuracy, 3.3V	V <sub>OUT,3.3V</sub>	MAX20075/76ATCB/V+ fixed-frequency PWM mode	3.25	3.3	3.35	V
Output Voltage Range	V <sub>OUT</sub>	MAX20075/76ATCC/V+	1		3.6	V
		MAX20075/76ATCA/V+ and MAX20075/76ATCB/V+ only	3		10	
FB Voltage Accuracy	V <sub>FB</sub>		0.985	1	1.015	V
FB Current	I <sub>FB</sub>	V <sub>FB</sub> = 1V, T <sub>A</sub> = +25°C		0.02		μA
FB Line Regulation		V <sub>SUP</sub> = 6V to 36V		0.02		%/V
High-Side Switch On-Resistance	R <sub>ON,HS</sub>	V <sub>BIAS</sub> = 5V, I <sub>LX</sub> = 1.2A		300	550	mΩ
Low-Side Switch On-Resistance	R <sub>ON,LS</sub>	V <sub>BIAS</sub> = 5V, I <sub>LX</sub> = 1.2A		200	350	mΩ
High-Side Current-Limit Threshold		MAX20076	1.67	1.9	2.13	A
		MAX20075	1.05	1.2	1.35	
Low-Side Negative Current-Limit Threshold	I <sub>NEG</sub>			-0.6		A
Soft-Start Ramp Time	I <sub>SS</sub>			2.5	5	ms
Minimum On-Time	t <sub>ON,V</sub>	MAX20075/76ATCC/V+			20	ns
Minimum On-Time	t <sub>ON</sub>	MAX20075/76ATCA/V+ and MAX20075/76ATCB/V+		66	85	ns
Maximum Duty Cycle			98	99		%
PWM Switching Frequency	f <sub>SW</sub>	Fixed	1.925	2.1	2.275	MHz
Spread-Spectrum Range	SS	V <sub>SPS</sub> = 5V		±6		%

**Electrical Characteristics (continued)**

( $V_{SUP} = V_{EN}$ ,  $V_{SUP} = 14V$ ,  $V_{SYNC} = 5V$ ,  $V_{OUT} = 5V$ ,  $T_J = -40^{\circ}C$  to  $+150^{\circ}C$ , unless otherwise noted.) (Notes 4, 5)

PARAMETER	SYMBOL	CONDITIONS	MIN	TYP	MAX	UNITS
<b>PGOOD</b>						
PGOOD Threshold, Rising	$V_{THR,PGD}$	$V_{OUT}$ rising	90	93.5	97	%
PGOOD Threshold, Falling	$V_{THF,PGD}$	$V_{OUT}$ falling	89.5	93	96.5	%
PGOOD Debounce Time	$t_{DEB}$	PWM mode, $V_{OUT}$ falling	65			$\mu s$
		MAX20076BATCB/VY+, $V_{OUT}$ rising	6			ms
PGOOD High-Leakage Current	$I_{LEAK,PGD}$	$T_A = +25^{\circ}C$			1	$\mu A$
PGOOD Low Level	$V_{OUT,PGD}$	Sinking 1mA			0.4	V
<b>LOGIC LEVELS</b>						
EN Level, High	$V_{IH,EN}$		2.4			V
EN Level, Low	$V_{IL,EN}$				0.6	V
EN Input Current	$I_{IN,EN}$	$V_{EN} = V_{SUP} = 14V$ , $T_A = +25^{\circ}C$			1	$\mu A$
External Input Clock Frequency			1.7		2.6	MHz
SYNC Threshold, High	$V_{IH,SYNC}$		1.4			V
SYNC Threshold, Low	$V_{IL,SYNC}$				0.4	V
SYNC Internal Pulldown	$R_{PD,MODE}$		1000			k $\Omega$
SPS Threshold, High	$V_{IH,SPS}$		1.4			V
SPS Threshold, Low	$V_{IL,SPS}$				0.4	V
SPS Internal Pulldown			1000			k $\Omega$
<b>THERMAL PROTECTION</b>						
Thermal Shutdown	$T_{SHDN}$	(Note 3)	175			$^{\circ}C$
Thermal-Shutdown Hysteresis	$T_{SHDN,HYS}$	(Note 3)	15			$^{\circ}C$

**Note 2:**  $V_{OUT}$  and  $V_{SUP}$  are the only electrical characteristics that differentiate the MAX25276 from the MAX20076 (with matching subscript).

**Note 3:** Guaranteed by design; not production tested.

**Note 4:** Limits are 100% tested at  $T_A = +25^{\circ}C$ . Limits over the operating range and relevant supply voltage are guaranteed by design and characterization. Typical values are at  $T_A = +25^{\circ}C$ .

**Note 5:** The device is designed for continuous operation up to  $T_J = +125^{\circ}C$  for 95,000 hours and  $T_J = +150^{\circ}C$  for 5,000 hours.

**Typical Operating Characteristics**

$V_{SUP} = V_{EN} = +14V$ , ( $T_A = +25^\circ C$ , unless otherwise noted.)

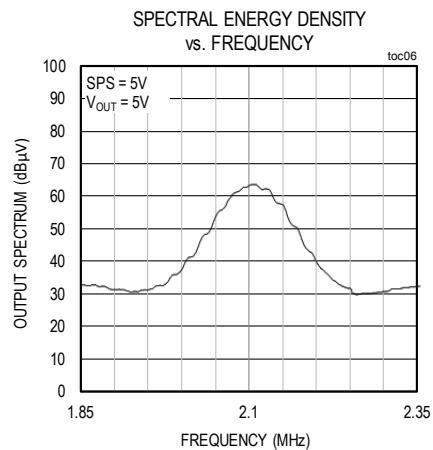
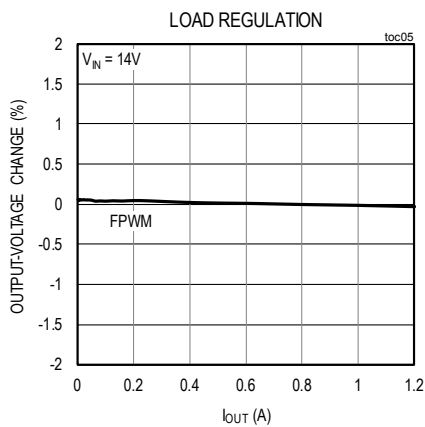
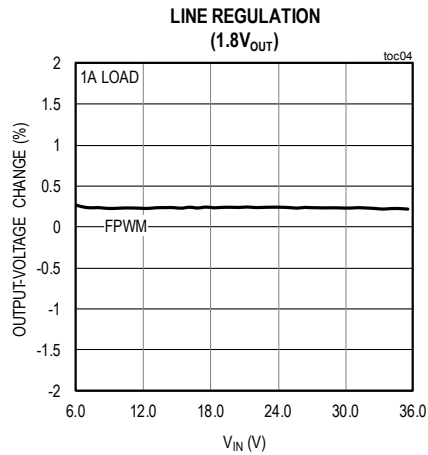
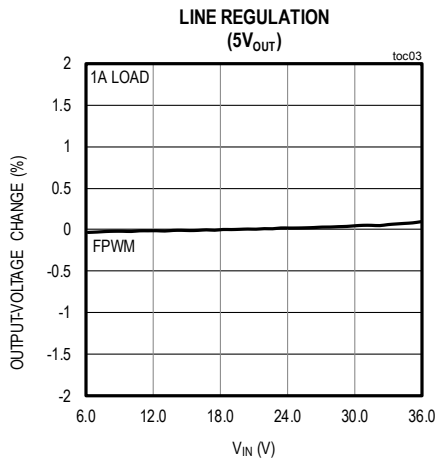
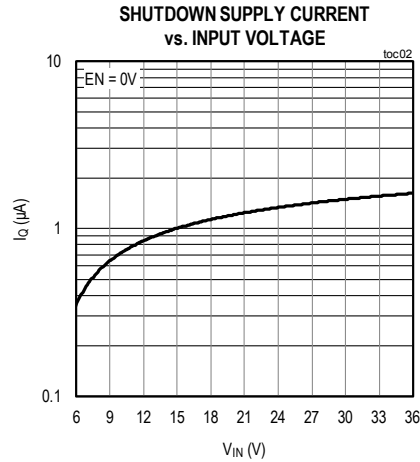
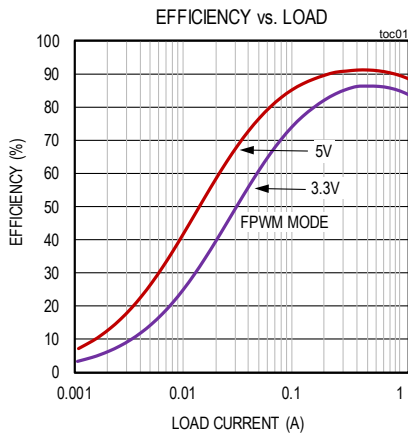

**Typical Operating Characteristics (continued)**

$V_{SUP} = V_{EN} = +14V$ , ( $T_A = +25^\circ C$ , unless otherwise noted.)

**STARTUP WAVEFORM  
(1.2A LOAD)**

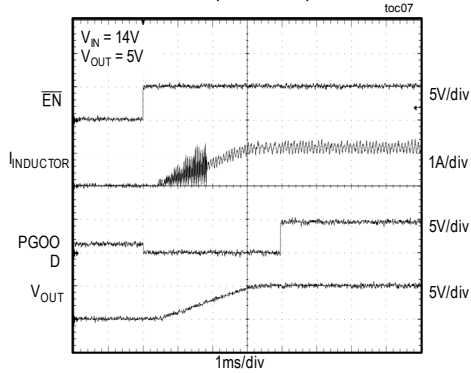

**SHUTDOWN WAVEFORM  
(1.2A LOAD)**

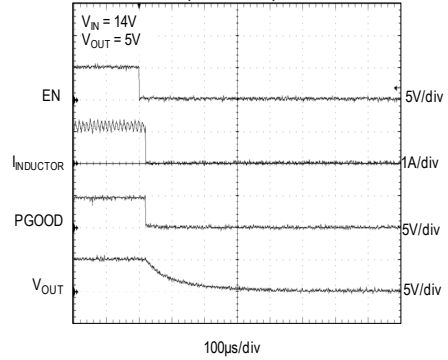

**STEADY-STATE SWITCHING WAVEFORMS  
(5V<sub>OUT</sub>)**

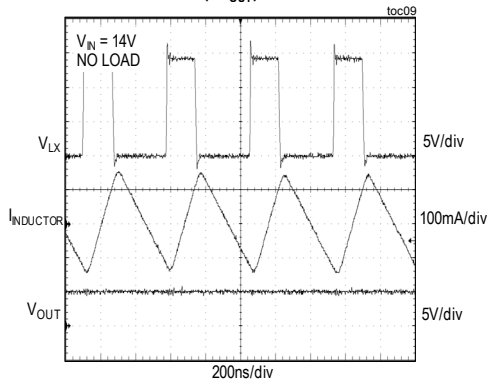

**MINIMUM ON-TIME  
(1.8V<sub>OUT</sub>)**

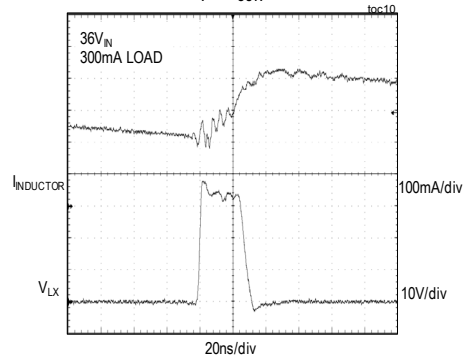

**SLOW VIN RAMP**

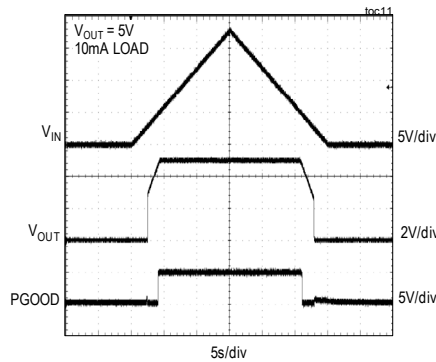

**Typical Operating Characteristics (continued)**

$V_{SUP} = V_{EN} = +14V$ , ( $T_A = +25^\circ C$ , unless otherwise noted.)

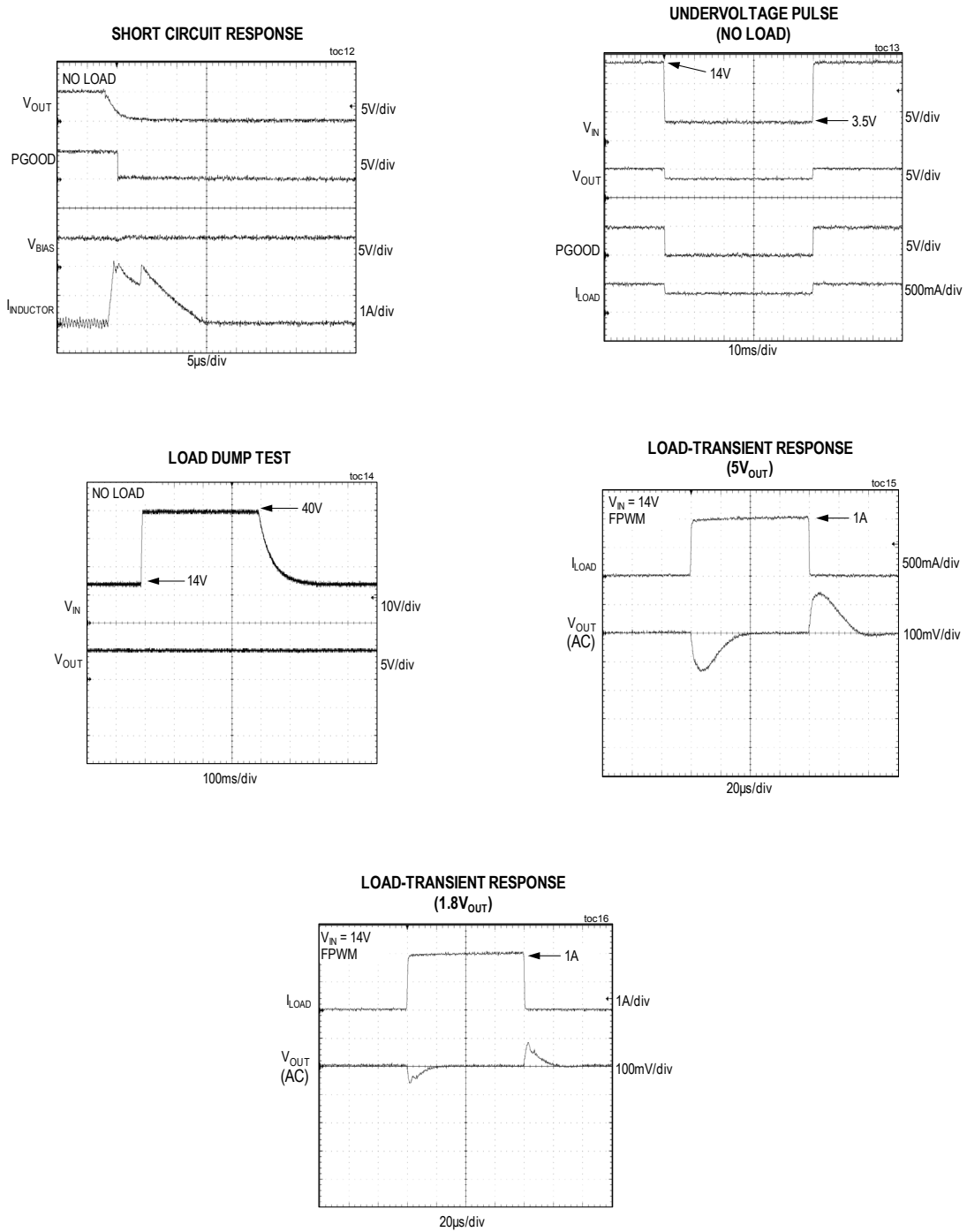

**Pin Configurations**

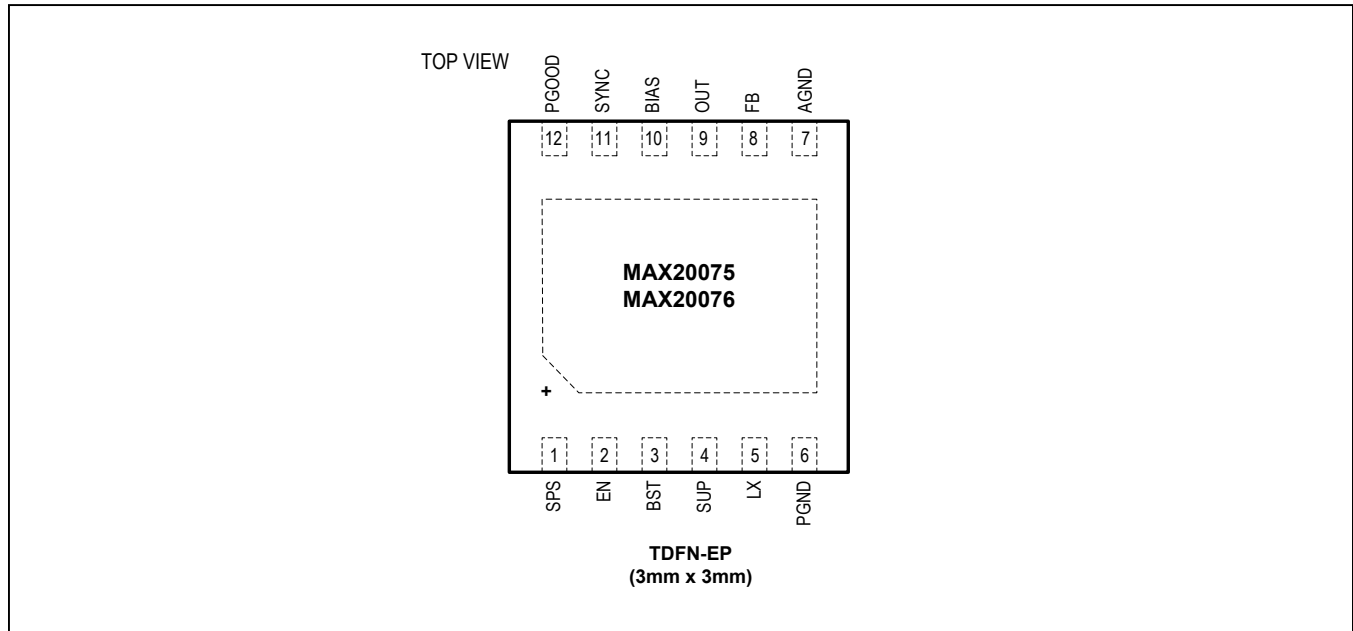

**Pin Description**

PIN	NAME	FUNCTION
1	SPS	Spread-Spectrum Enable. Connect logic-high to enable spread spectrum of internal oscillator or logic-low to disable spread spectrum. This pin has a 1MΩ internal pulldown.
2	EN	High-Voltage-Compatible Enable Input. If this pin is low, the part is off.
3	BST	Bootstrap Pin for HS Driver. It is recommended to use 0.1μF from BST to LX.
4	SUP	Supply Input. Connect a 4.7μF ceramic capacitor from SUP to PGND.
5	LX	Buck Switching Node. High impedance when part is off. Connect a 4.7μH inductor between LX and OUT.
6	PGND	Power Ground. Ground return path for all high-current/high-frequency noisy signals.
7	AGND	Analog Ground. Ground return path for all 'quiet' signals.
8	FB	Feedback Pin. Connect a resistor-divider from OUT to FB to ground for external adjustment of the output voltage. Connect FB to BIAS for internal fixed voltages.
9	OUT	Buck Regulator Output-Voltage-Sense Input. Bypass OUT to PGND with 22μF ceramic capacitor.
10	BIAS	5V Internal BIAS Supply. Connect a 1μF (min) ceramic capacitor to AGND.
11	SYNC	Connect to BIAS to Enable FPWM Operation. This pin has a 1MΩ internal pulldown.
12	PGOOD	Open-Drain Reset Output. External pullup required.
—	EP	Exposed Pad. EP <b>must</b> be connected to ground plane on PCB, but is not a current-carrying path and is only needed for thermal transfer.

## Detailed Description

The MAX20075/MAX20076/MAX25276 family of small, current-mode-controlled buck converters features synchronous rectification and requires no external compensation network. The devices are designed for 1.2A and 0.6A output current (MAX20076/MAX25276 and MAX20075, respectively), and can stay in dropout by running at 99% duty cycle. They provide an accurate output voltage within the 5.5V to 18V input range. With 20ns minimum on-time the devices can regulate output voltages of < 3V directly off the car battery. This eliminates the need for traditional two-stage designs for voltage rails < 3V. Voltage quality can be monitored by observing the PGOOD signal. The devices operate at 2.1MHz (typ) frequency, which allows for small external components, reduced output ripple, and guarantees no AM band interference.

The devices operate from a 3.5V to 36V supply voltage and can tolerate transients up to 40V, making them ideal for automotive applications. The devices are available in factory-trimmed output voltages (5V, 3.3V) and are programmable with an external resistor-divider. For fixed output voltages outside of 3.3V and 5V, contact factory for availability.

### Enable Input (EN)

The devices are activated by driving EN high. EN is compatible from a 3.3V logic level to automotive battery levels. EN can be controlled by microcontrollers and automotive KEY or CAN inhibit signals. The EN input has no internal pullup/pulldown current to minimize the overall quiescent supply current. To realize a programmable undervoltage-lockout level, use a resistor-divider from SUP to EN to AGND.

### BIAS/UVLO

The devices feature undervoltage lockout. When the device is enabled, an internal bias generator turns on. LX begins switching after  $V_{BIAS}$  has exceeded the internal undervoltage-lockout level,  $V_{UVLO} = 2.73V$  (typ).

### Soft-Start

The devices feature an internal soft-start timer. The output voltage soft-start ramp time is 2.5ms (typ). If a short circuit or undervoltage is encountered after the soft-start timer

has expired, the device is disabled for 6ms (typ) and then reattempts soft-start again. This pattern repeats until the short circuit has been removed.

### Oscillator/Synchronization and Efficiency (SYNC)

The devices have an on-chip oscillator that provides a 2.1MHz (typ) switching frequency. For MAX20075/MAX20076/MAX25276, only Forced-PWM operation is recommended. Connect SYNC to BIAS to enable the internal clock operation. For synchronizing to an external clock, apply the clock at the SYNC pin.

### Controlled EMI with Forced-Fixed Frequency

In FPWM mode, the devices attempt to operate at a constant switching frequency for all load currents. For tightest frequency control, apply the operating frequency to SYNC. The advantage of this mode is a constant switching frequency, which improves EMI performance; the disadvantage is that considerable current can be thrown away. If the load current during a switching cycle is less than the current flowing through the inductor, the excess current is diverted to AGND.

### Extended Input Voltage Range

In some cases, the devices are forced to deviate from its operating frequency, independent of the state of SYNC. For input voltages above 18V, the required duty cycle to regulate its output may be smaller than the minimum on-time (66ns, typ). In this event, the devices are forced to lower their switching frequency by skipping pulses. If the output voltage being regulated is < 3V, then the MAX20075ATCC/V+ and MAX20076ATCC/V+ can enable this at 2.1MHz without skipping pulses.

If the input voltage is reduced and the devices approach dropout, the devices try to turn on the high-side FET continuously. To maintain gate charge on the high-side FET, the BST capacitor must be periodically recharged. To ensure proper charge on the BST capacitor when in dropout, the high-side FET is turned off every 20 $\mu$ s and the low-side FET is turned on for about 200ns. This gives an effective duty cycle of > 99% and a switching frequency of 50kHz when in dropout. Since the MAX20075ATCC/V+ and MAX20076ATCC/V+ support voltages of < 3V it does not support operation with  $SUP \leq OUT$ .

### Spread-Spectrum Option

The devices have an optional spread spectrum enabled by the SPS pin. If SPS is pulled high, then the internal operating frequency varies by  $\pm 6\%$  relative to the internally generated operating frequency of 2.1MHz (typ). Spread spectrum is offered to improve EMI performance of the devices.

The internal spread spectrum does not interfere with the external clock applied on the SYNC pin. It is active only when the devices are running with an internally generated switching frequency.

### Power-Good (PGOOD)

The devices feature an open-drain power-good output. PGOOD is an active-high output that pulls low when the output voltage is below 93% of its nominal value. PGOOD is high impedance when the output voltage is above 93.5% of its nominal value. Connect a 20k $\Omega$  (typ) pullup resistor to an external supply or the on-chip BIAS output.

### Overcurrent Protection

The devices limit the peak output current to 1.9A (typ). The accuracy of the current limit is  $\pm 12\%$ , which makes selection of external components very easy. To protect against short-circuit events, the devices shut off when OUT is below 50% of OUT voltage (25% of OUT voltage for the MAX20075ATCC/V+ and MAX20076ATCC/V+) and an overcurrent event is detected. The devices attempt a soft-start restart every 7ms and stay off if the short circuit has not been removed. When the current limit is no longer present, it reaches the output voltage by following the normal soft-start sequence. If the devices' die reaches the thermal limit of 175°C (typ) during the current-limit event, it immediately shuts off.

### Thermal-Overload Protection

The devices feature thermal-overload protection. The device turns off when the junction temperature exceeds +175°C (typ). Once the device cools by 15°C (typ), it turns back on with a soft-start sequence.

## Applications Information

### Setting the Output Voltage

Connect FB to BIAS for a fixed +5V/3.3V output voltage. To set the output to other voltages between 1V and 10V, connect a resistive divider from output (OUT) to FB to AGND (Figure 1). Select  $R_{FB2}$  (FB to AGND resistor) less than or equal to 500k $\Omega$ . Calculate  $R_{FB1}$  (OUT to FB resistor) with the following equation:

$$R_{FB1} = R_{FB2} [(V_{OUT}/V_{FB}) - 1]$$

where  $V_{FB} = 1V$  (see the [Electrical Characteristics](#) table).

Note: MAX200075CATCC/VY+ only comes with fixed internal  $V_{OUT}$ . Connect FB to BIAS for the respective output voltage.

### Inductor Selection

The design is optimized with 4.7 $\mu H$  inductor for all input and output voltage conditions. The nominal standard value selected should be within  $\pm 50\%$  of 4.7 $\mu H$ .

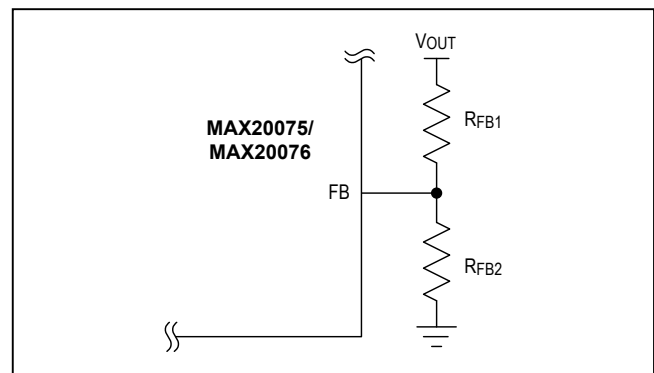

Figure 1. Connecting a Resistive Divider from Output to FB to AGND

### Input Capacitor

A low-ESR ceramic input capacitor of 4.7µF is recommended for proper device operation. This value can be adjusted based on application input-voltage ripple requirements.

The discontinuous input current of the buck converter causes large input ripple current. The switching frequency, peak inductor current, and the allowable peak-to-peak input-voltage ripple dictate the input-capacitance requirement. Increasing the switching frequency or the inductor value lowers the peak-to-average current ratio, yielding a lower input-capacitance requirement.

The input ripple comprises mainly of  $\Delta V_Q$  (caused by the capacitor discharge) and  $\Delta V_{ESR}$  (caused by the ESR of the input capacitor). The total voltage ripple is the sum of  $\Delta V_Q$  and  $\Delta V_{ESR}$ . Assume that input-voltage ripple from the ESR and the capacitor discharge is equal to 50% each. The following equations show the ESR and capacitor requirement for a target voltage ripple at the input:

#### Equation 1:

$$ESR = \frac{\Delta V_{ESR}}{I_{OUT} + (\Delta I_{P-P} / 2)}$$

$$C_{IN} = \frac{I_{OUT} \times D(1-D)}{\Delta V_Q \times f_{SW}}$$

where:

$$\Delta I_{P-P} = \frac{(V_{IN} - V_{OUT}) \times V_{OUT}}{V_{IN} \times f_{SW} \times L}$$

and:

$$D = \frac{V_{OUT}}{V_{IN}}$$

where  $I_{OUT}$  is the output current,  $D$  is the duty cycle, and  $f_{SW}$  is the switching frequency. Use additional input capacitance at lower input voltages to avoid possible undershoot below the UVLO threshold during transient loading.

### Output Capacitor

For optimal phase margin ( $> 70^\circ$ , typ) with internal fixed-voltage options, a 22µF output capacitor is recommended. A lower output capacitor can be used at the expense of lower phase margin. For all other designs a minimum of 10µF output capacitor is required. Additional output capacitance may be needed based on application-

specific output-voltage ripple requirements. If the total output capacitance required is  $> 70\mu F$ , contact the factory for an optimized solution.

The allowable output-voltage ripple and the maximum deviation of the output voltage during step-load currents determine the output capacitance and its ESR. The output ripple comprises  $\Delta V_Q$  (caused by the capacitor discharge) and  $\Delta V_{ESR}$  (caused by the ESR of the output capacitor). Use low-ESR ceramic or aluminum electrolytic capacitors at the output. For aluminum electrolytic capacitors, the entire output ripple is contributed by  $\Delta V_{ESR}$ . Use the  $ESR_{OUT}$  equation to calculate the ESR requirement and choose the capacitor accordingly. If using ceramic capacitors, assume the contribution to the output ripple voltage from the ESR and the capacitor discharge to be equal. The following equations show the output capacitance and ESR requirement for a specified output-voltage ripple.

#### Equation 2:

$$ESR = \frac{\Delta V_{ESR}}{\Delta I_{P-P}}$$

$$C_{OUT} = \frac{\Delta I_{P-P}}{8 \times \Delta V_Q \times f_{SW}}$$

where:

$$\Delta I_{P-P} = \frac{(V_{IN} - V_{OUT}) \times V_{OUT}}{V_{IN} \times f_{SW} \times L}$$

and:

$$V_{OUT\_RIPPLE} = \Delta V_{ESR} + \Delta V_Q$$

$\Delta I_{P-P}$  is the peak-to-peak inductor current as calculated above, and  $f_{SW}$  is the converter's switching frequency. The allowable deviation of the output voltage during fast transient loads also determines the output capacitance and its ESR. The output capacitor supplies the step-load current until the converter responds with a greater duty cycle. The response time ( $t_{RESPONSE}$ ) depends on the closed-loop bandwidth of the converter. The high switching frequency of the devices allows for a higher closed-loop bandwidth, thus reducing  $t_{RESPONSE}$  and the output-capacitance requirement. The resistive drop across the output capacitor's ESR and the capacitor discharge causes a voltage droop during a step load. Use a combination of low-ESR tantalum and ceramic capacitors for better transient load and ripple/noise performance.

Keep the maximum output-voltage deviations below the tolerable limits of the electronics being powered. When using a ceramic capacitor, assume an 80% and 20% contribution from the output-capacitance discharge and the ESR drop, respectively. Use the following equations to calculate the required ESR and capacitance value:

**Equation 3:**

$$ESR_{OUT} = \frac{\Delta V_{ESR}}{I_{STEP}}$$

$$C_{OUT} = \frac{I_{STEP} \times t_{RESPONSE}}{\Delta V_Q}$$

where  $I_{STEP}$  is the load step and  $t_{RESPONSE}$  is the response time of the converter. The converter response time depends on the control-loop bandwidth.

### PCB Layout Guidelines

Careful PCB layout is critical to achieve low switching power losses and clean, stable operation. Use a multi-layer board wherever possible for better noise immunity. Follow the guidelines below for a good PCB layout:

- 1) The input capacitor (4.7 $\mu$ F, see [Figure 2](#), [Figure 3](#), and [Figure 4](#)) should be placed right next to the SUP pin. Since the MAX20075/MAX20076/MAX25276 operate at 2.1MHz switching frequency, this placement is critical for effective decoupling of high-frequency noise from the SUP pins.
- 2) Solder the exposed pad to a large copper-plane area under the device. To effectively use this copper area as heat exchanger between the PCB and ambient, expose the copper area on the top and bottom side. Add a few small vias or one large via on the copper pad for efficient heat transfer. Connect the exposed pad to PGND, ideally at the return terminal of the output capacitor.
- 3) Isolate the power components and high-current paths from sensitive analog circuitry.
- 4) Keep the high-current paths short, especially at the ground terminals. This practice is essential for stable, jitter-free operation.
- 5) Connect PGND and AGND together, preferably at the return terminal of the output capacitor. Do not connect them anywhere else.
- 6) Keep the power traces and load connections short. This practice is essential for high efficiency. Use thick copper PCB to enhance full-load efficiency and power-dissipation capability.
- 7) Route high-speed switching nodes away from sensitive analog areas. Use internal PCB layers as PGND to act as EMI shields to keep radiated noise away from the device and analog bypass capacitor.

**Typical Application Circuits**

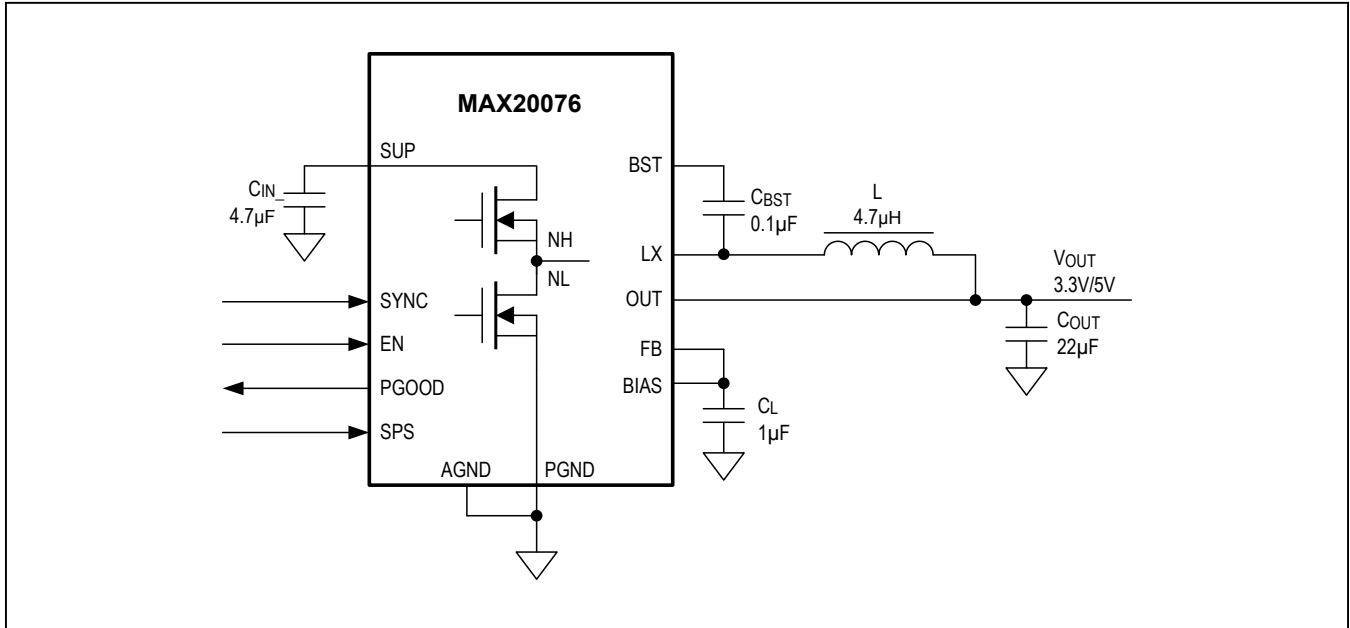

Figure 2. MAX20076 3.3V/5V Fixed 1.2A Output in 12-Pin TDFN Package

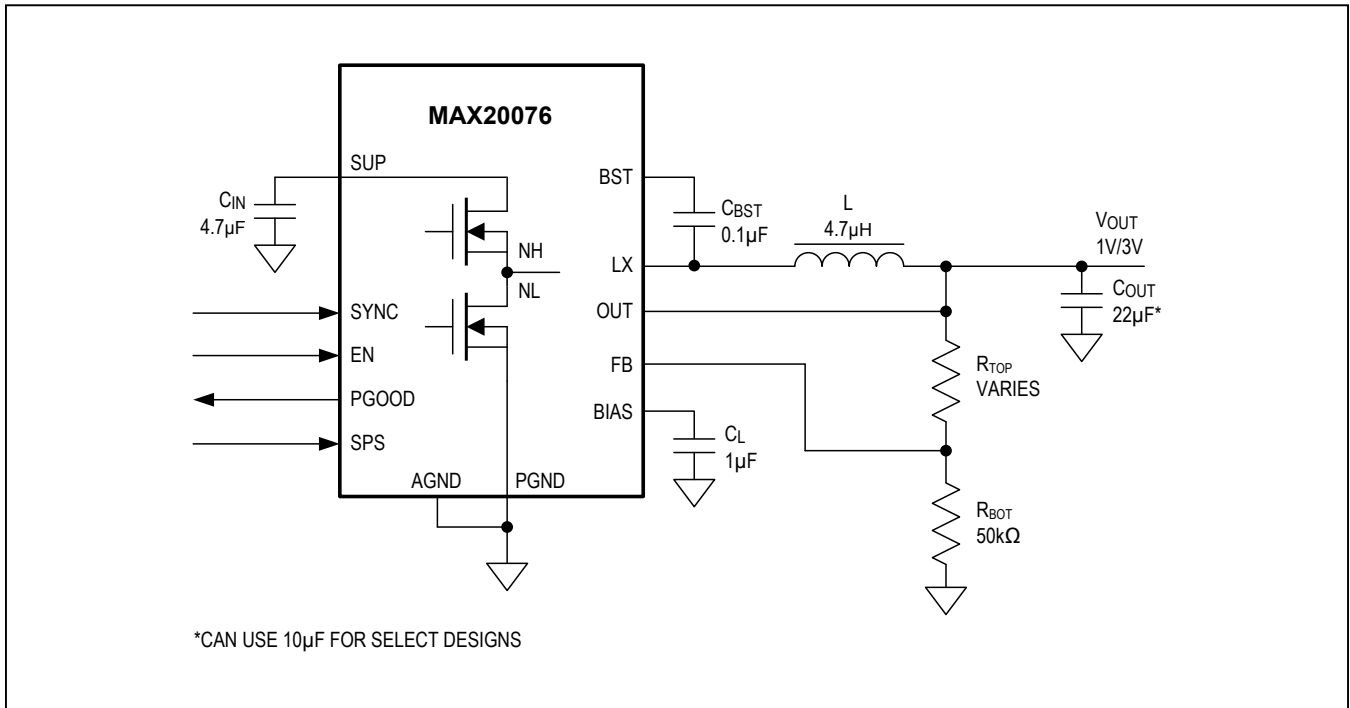

Figure 3. MAX20076ATCC/V+ 1V/3V Variable 1.2A Output in 12-Pin TDFN Package

**Typical Application Circuits (continued)**

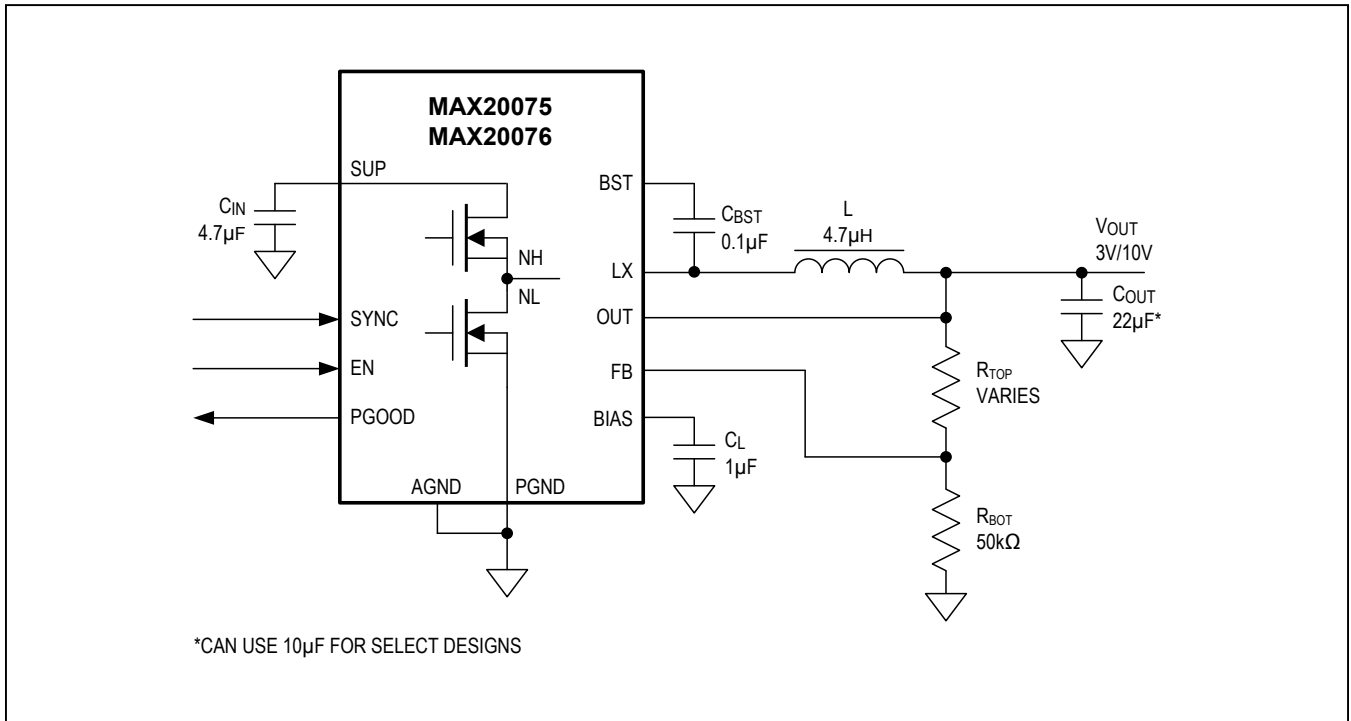

Figure 4. MAX20075/MAX20076 3V/10V Variable Output

### Ordering Information

PART	TEMP RANGE	PIN-PACKAGE	DESCRIPTION	I <sub>OUT</sub>
<b>MAX20075</b> ATCA/V+	-40°C to +125°C	TD1233+2C	Fixed 5V output or 3V to 10V external resistor-divider	0.6A
MAX20075ATCB/V+	-40°C to +125°C	TD1233+2C	Fixed 3.3V output or 3V to 10V external resistor-divider	0.6A
MAX20075ATCC/V+	-40°C to +125°C	TD1233+2C	External resistor-divider from 1V to 3.6V	0.6A
<b>MAX20076</b> ATCA/V+	-40°C to +125°C	TD1233+2C	Fixed 5V output or 3V to 10V external resistor-divider	1.2A
MAX20076ATCB/V+	-40°C to +125°C	TD1233+2C	Fixed 3.3V output or 3V to 10V external resistor-divider	1.2A
MAX20076ATCC/V+	-40°C to +125°C	TD1233+2C	External resistor-divider from 1V to 3.6V	1.2A
MAX20076ATCC/VY+	-40°C to +125°C	TD1233Y+2C	External resistor-divider from 1V to 3.6V	1.2A
MAX20076BATCB/VY+	-40°C to +125°C	TD1233Y+2C	Fixed 3.3V output or 3V to 10V external resistor-divider	1.2A
<b>MAX25276</b> ATCA/VY+	-40°C to +125°C	TD1233Y+3C	2.1MHz, fixed 5.147V output or 3V to 10V external resistor-divider	1.2A

**Note:** All parts are OTP versions, no metal mask differences.

/V denotes an automotive-qualified part.

Y = Side-wettable package.

+Denotes a lead(Pb)-free/RoHS-compliant package.

### Chip Information

PROCESS: CMOS

**Revision History**

REVISION NUMBER	REVISION DATE	DESCRIPTION	PAGES CHANGED
0	2/17	Initial release	—
1	8/17	Added MAX20076BATCB/VY+ to <a href="#">Ordering Information</a> as a future product; moved <a href="#">Package Information</a> table to front of data sheet	2, 15
2	9/17	Removed future product status from MAX20076BATCB/VY+ in <a href="#">Ordering Information</a>	15
3	10/17	Updated <a href="#">General Description</a> section, BIAS Voltage in <a href="#">Electrical Characteristics</a> table, <a href="#">Detailed Description</a> and <a href="#">Skip-Mode Operation</a> sections	1, 3, 9
4	1/18	Updated <a href="#">Package Information</a> , <a href="#">Electrical Characteristics</a> table, added new <a href="#">Figure 1</a> , added <a href="#">Setting the Output Voltage</a> section, renumbered <a href="#">Figures 2–4</a>	2, 3, 10, 13, 14
5	3/18	Updated <a href="#">Absolute Maximum Ratings</a> section, and <a href="#">Package Information</a> , <a href="#">Electrical Characteristics</a> and <a href="#">Ordering Information</a> tables	2–4, 15
6	6/18	Updated <a href="#">Absolute Maximum Ratings</a> , added <a href="#">Recommended Operating Conditions</a> section, updated <a href="#">Electrical Characteristics</a> global conditions, table, and notes	2–5
7	7/18	Removed future product status from MAX25276ATCA/VY+ in <a href="#">Ordering Information</a> .	16
8	7/18	Updated title, and <a href="#">General Description</a> , <a href="#">Benefits and Features</a> , <a href="#">Detailed Description</a> , and <a href="#">PCB Layout Guidelines</a> sections	1–17
9	1/19	Updated <a href="#">Absolute Maximum Ratings</a> , <a href="#">Electrical Characteristics</a> , <a href="#">Detailed Description</a> , and <a href="#">Ordering Information</a>	2–4, 11, 16
10	8/19	Removed mention of quiescent current from title; updated <a href="#">General Description</a> , <a href="#">Benefits and Features</a> , <a href="#">Electrical Characteristics</a> table, <a href="#">Typical Operating Characteristics</a> , <a href="#">Pin Description</a> , <a href="#">Detailed Description</a> , and <a href="#">Ordering Information</a>	1–15
11	11/19	Updated <a href="#">Ordering Information</a> to add MAX20076ATCC/VY+	15
12	11/21	Updated <a href="#">Ordering Information</a>	15



Information furnished by Analog Devices is believed to be accurate and reliable. However, no responsibility is assumed by Analog Devices for its use, nor for any infringements of patents or other rights of third parties that may result from its use. Specifications subject to change without notice. No license is granted by implication or otherwise under any patent or patent rights of Analog Devices. Trademarks and registered trademarks are the property of their respective owners.

## Looking for pricing, stock, or lifecycle information?

Click below to explore more details on WIN SOURCE:

- ⊖ [View MAX20075ATCA/V+T on WIN SOURCE](#)
- ⊖ [Analog Devices Inc. Information](#)

## Optimize Your Supply Chain with WIN SOURCE Solutions

- ✓ Global Sourcing Solution
- ✓ Obsolete Management
- ✓ Cost Control Management
- ✓ Shortage Management
- ✓ Alternative Solution
- ✓ Excess Inventory Management