



**THE DATASHEET OF
MAX77654DENV+T**



Click [here](#) to ask an associate for production status of specific part numbers.

MAX77654

Ultra-Low Power PMIC Featuring Single-Inductor, 3-Output Buck-Boost, 2-LDOs, Power-Path Charger for Small Li+, and Ship Mode

General Description

The MAX77654 provides highly-integrated battery charging and power supply solutions for low-power applications where size and efficiency are critical. The IC features a SIMO buck-boost regulator that provides three independently programmable power rails from a single inductor to minimize total solution size. Two 100mA LDOs provide ripple rejection for audio and other noise-sensitive applications. The LDOs can also be configured as load switches to manage power consumption by disconnecting external blocks when not required. A highly-configurable linear charger supports a wide range of Li+ battery capacities and includes battery temperature monitoring for additional safety (JEITA).

This device includes three GPIOs and an analog multiplexer that switches several internal voltage and current signals to an external node for monitoring with an external ADC. A bidirectional I²C serial interface allows for configuring and checking the status of the devices. An internal on/off controller provides a controlled startup sequence for the regulators and provides supervisory functionality while they are on. Numerous factory programmable options allow the device to be tailored for many applications, enabling faster time to market.

Applications

- Bluetooth Headphones, Hearables
- Wireless Speakers
- Fitness, Health, and Activity Monitors
- Wearables
- Safety and Security Monitors
- Sensor Nodes
- Portable Consumer Devices
- Internet of Things (IoT)

Benefits and Features

- Low Power
 - Factory Ship Mode (<200nA I_Q)
 - 300nA Shutdown Current
 - 6μA Typical I_Q with all Outputs (3x SIMO and 2x LDOs) Enabled in Low-Power Mode
- Smart Power Selector™ Li+/Li-Poly Charger
 - Programmable Charge Current from 7.5mA to 300mA
 - Programmable Charge Voltage from 3.6V to 4.6V
 - Programmable Termination Current from 0.375mA to 45mA
 - JEITA Battery Temperature Monitors for Safe Charging
- Single-Inductor Multiple-Output (SIMO) Regulator
 - 3x Buck/Buck-Boost Regulators, 1x Inductor
 - 2.5V to 5.5V Input Voltage Range
 - 0.8V to 5.5V Output Voltage Range
 - 500mA Total Output Current (3.7V_{IN}, 1.8V_{OUT})
 - Up to 91% Efficiency (3.7V_{IN}, 1.8V_{OUT})
- Low Dropout Regulator (LDO)
 - 2x Outputs Configurable as LDO or Load Switch (LSW)
 - 1.71V to 5.5V Input Voltage Range in LDO Mode
 - 1.3V to 5.5V Input Voltage Range in LSW Mode
 - 0.8V to 3.975V Output Voltage Range in LDO Mode
 - Up to 100mA Output Current
- Flexible Power Sequencer (FPS)
 - 3x GPIO Resources
 - Dedicated Enable Pin
 - I²C Interface
 - Watchdog Timer
 - Analog MUX Output for Power Monitoring
 - 2.79mm x 2.34mm, 30-Bumps, 0.4mm Pitch Wafer-Level Package (WLP)
 - <40mm² Solution Size

Smart Power Selector is a trademark of Maxim Integrated Products, Inc.

[Ordering Information](#) appears at end of data sheet.

19-100560; Rev 9; 3/23

© 2023 Analog Devices, Inc. All rights reserved. Trademarks and registered trademarks are the property of their respective owners.

One Analog Way, Wilmington, MA 01887 U.S.A. | Tel: 781.329.4700 | © 2023 Analog Devices, Inc. All rights reserved.

MAX77654

Ultra-Low Power PMIC Featuring Single-Inductor, 3-Output Buck-Boost, 2-LDOs, Power-Path Charger for Small Li+, and Ship Mode

Simplified Block Diagram

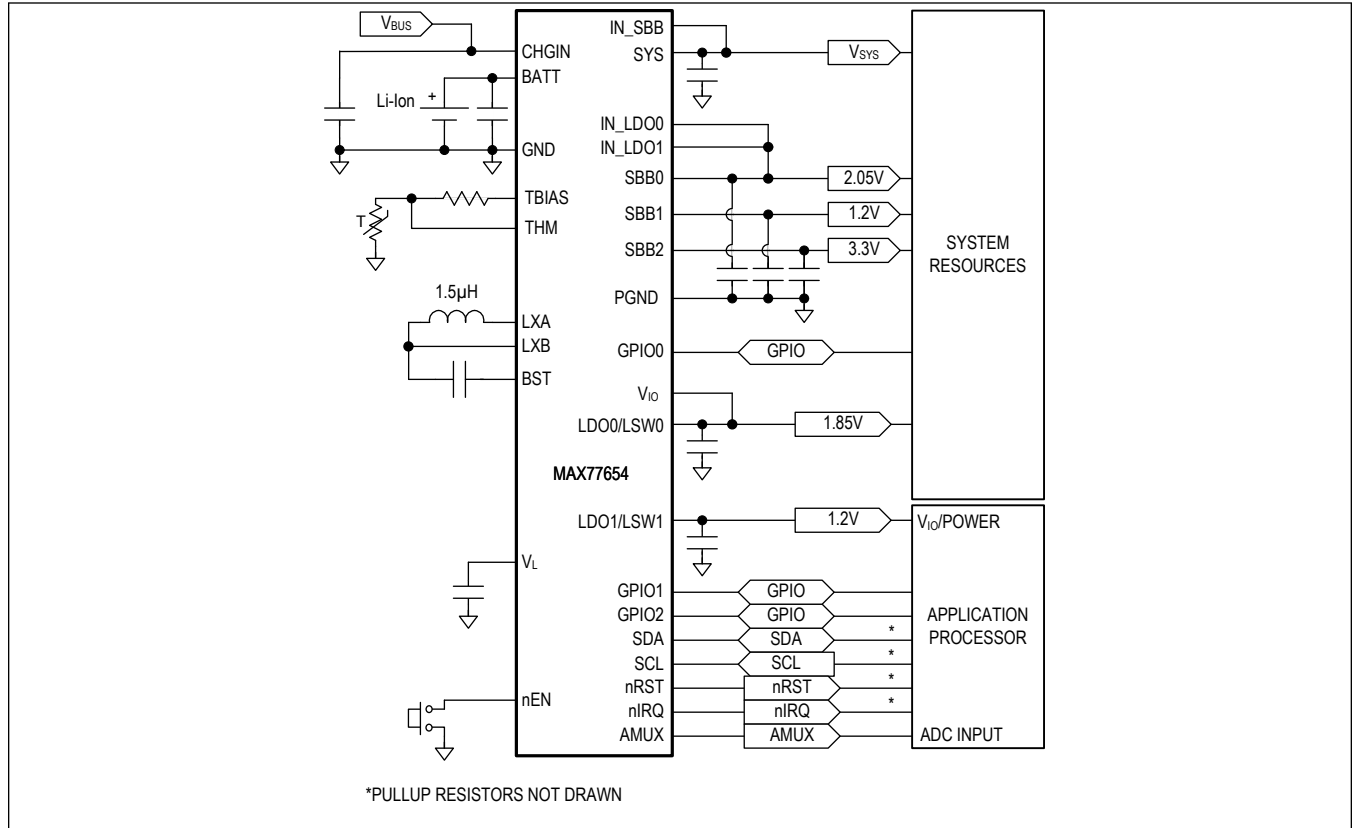

TABLE OF CONTENTS

General Description	1
Applications	1
Benefits and Features	1
Simplified Block Diagram	2
Absolute Maximum Ratings	9
Package Information	9
WLP	9
Electrical Characteristics	10
Electrical Characteristics—Global Resources	10
Electrical Characteristics—Smart Power Selector Charger	13
Electrical Characteristics—Adjustable Thermistor Temperature Monitors	16
Electrical Characteristics—Analog Multiplexer	17
Electrical Characteristics—SIMO Buck-Boost	18
Electrical Characteristics—Low Dropout Linear Regulator (LDO)/Load Switch (LSW)	19
Electrical Characteristics—I ² C Serial Communication	20
Typical Operating Characteristics	23
Pin Configurations	29
MAX77654xENV	29
MAX77654xENVN	30
Pin Description	30
Detailed Description	33
Part Number Decoding	33
Support Material	36
Top-Level Interconnect Simplified Diagram	36
Detailed Description—Global Resources	38
Features and Benefits	38
Voltage Monitors	38
SYS POR Comparator	38
SYS Undervoltage-Lockout Comparator	38
SYS Overvoltage-Lockout Comparator	39
Chip Identification	39
nEN Enable Input	39
nEN Manual Reset	39
nEN Dual-Functionality: Push-Button vs. Slide-Switch	39
nEN Internal Pullup Resistors to V _{CCINT}	40
Interrupts (nIRQ)	40
Reset Output (nRST)	41
General-Purpose Input Output (GPIO)	41
Alternate Mode	42

TABLE OF CONTENTS (CONTINUED)

On/Off Controller	43
Top Level On/Off Controller	44
On/Off Controller Transition Table	44
Internal Wake-Up Flags	45
Reset and Off Sequences	46
Power-Up/Down Sequence	47
Flexible Power Sequencer (FPS)	48
Startup Timing Diagram Due to nEN	49
Startup Timing Diagram Due to Charge Source Insertion	50
Force Enabled/Disabled Channels	50
Factory-Ship Mode State	51
Debounced Inputs (nEN, GPI, CHGIN)	51
Watchdog Timer (WDT)	52
Detailed Description—Smart Power Selector Charger	53
Charger Symbol Reference Guide	53
Smart Power Selector	54
Input Current Limiter	54
Minimum Input Voltage Regulation	55
Minimum System Voltage Regulation	56
Die Temperature Regulation	56
Charger State Machine	57
Charger-Off State	58
Prequalification State	58
Fast-Charge States	58
Top-Off State	58
Done State	59
Prequalification Timer Fault State	59
Fast-Charge Timer Fault State	59
Battery Temperature Fault State	59
JEITA-Modified States	59
Typical Charge Profile	60
Charger Applications Information	60
Configuring a Valid System Voltage	60
CHGIN/SYS/BATT Capacitor Selection	60
Detailed Description—Adjustable Thermistor Temperature Monitors	61
Thermistor Bias	62
Configurable Temperature Thresholds	63
Applications Information	64
Using Different Thermistor β	64

TABLE OF CONTENTS (CONTINUED)

NTC Thermistor Selection	65
Detailed Description—Analog Multiplexer	65
Measuring Battery Current	66
Method for Measuring Discharge Current	66
Method for Measuring Charge Current	67
Detailed Description—SIMO Buck-Boost	67
SIMO Features and Benefits	67
SIMO Detailed Block Diagram	68
SIMO Control Scheme	68
Drive Strength	69
SIMO Soft-Start	69
SIMO Registers	70
SIMO Active Discharge Resistance	70
SIMO Buck Mode	70
Applications Information	71
SIMO Available Output Current	71
Inductor Selection	71
Input Capacitor Selection	72
Boost Capacitor Selection	72
Output Capacitor Selection	72
Example Component Selection	73
Inductor, Peak Current Limit, and Input Capacitor	73
Output Capacitors	74
Summary	75
SIMO Switching Frequency	76
Unused Outputs	76
PCB Layout Guide	77
Capacitors	77
Input Capacitor at IN_SBB	77
Output Capacitors at SBBx	77
Inductor	77
Ground Connections	77
Example PCB Layout	78
Detailed Description—Low Dropout Linear Regulator (LDO)/Load Switch (LSW)	79
Features and Benefits	79
LDO/LSW Simplified Block Diagram	79
LDO/LSW Active-Discharge Resistor	79
LDO/LSW Soft-Start	80
Load Switch Configuration	80

TABLE OF CONTENTS (CONTINUED)

Applications Information	81
Input Capacitor Selection	81
Output Capacitor Selection	81
Detailed Description—I ² C Serial Communication	82
General Description	82
Features	82
I ² C Simplified Block Diagram	82
I ² C System Configuration	83
I ² C Interface Power	84
I ² C Data Transfer	84
I ² C Start and Stop Conditions	84
I ² C Acknowledge Bit	84
I ² C Slave Address	85
I ² C Clock Stretching	85
I ² C General Call Address	86
I ² C Device ID	86
I ² C Communication Speed	86
I ² C Communication Protocols	87
Writing to a Single Register	87
Writing Multiple Bytes to Sequential Registers	88
Reading from a Single Register	90
Reading from Sequential Registers	91
Engaging HS-Mode for Operation up to 3.4MHz	92
Register Map	93
MAX77654	93
Register Details	94
Typical Application Circuits	117
Typical Applications Circuit	117
Ordering Information	118
Revision History	119

LIST OF FIGURES

Figure 1. Part Number Decode	33
Figure 2. Top-Level Interconnect Simplified Diagram	37
Figure 3. nEN Usage Timing Diagram	39
Figure 4. nEN Pullup Resistor Configuration	40
Figure 5. GPIOx Block Diagram	42
Figure 6. Top Level On/Off Controller State Diagram	44
Figure 7. On/Off Controller Reset and Off-Action Sequences	46
Figure 8. Power-Up/Down Sequence	47
Figure 9. Flexible Power Sequencer Basic Timing Diagram	48
Figure 10. Startup Timing Diagram Due to nEN	49
Figure 11. Startup Timing Diagram Due to Charge Source Insertion	50
Figure 12. Debounced Inputs	51
Figure 13. Watchdog Timer State Machine	52
Figure 14. Charger Simplified Control Loops	54
Figure 15. Charger State Diagram	57
Figure 16. Example Battery Charge Profile	60
Figure 17. Safe-Charging Profile Example	62
Figure 18. Thermistor Bias State Diagram	63
Figure 19. Thermistor Circuit with Adjusting Series and Parallel Resistors	64
Figure 20. SIMO Detailed Block Diagram	68
Figure 21. Component Selection—High Utilization	73
Figure 22. Component Selection—Final Current Peak Limits	74
Figure 23. Component Selection—Expected Ripple	75
Figure 24. PCB Top-Layer and Component Placement Example	78
Figure 25. LDO Simplified Block Diagram	79
Figure 26. LDO to LSW Transition Waveform	80
Figure 27. I ² C Simplified Block Diagram	83
Figure 28. I ² C System Configuration	83
Figure 29. I ² C Start and Stop Conditions	84
Figure 30. Acknowledge Bit	85
Figure 31. Slave Address Example	85
Figure 32. Writing to a Single Register with the Write Byte Protocol	87
Figure 33. Writing to Sequential Registers X to N	89
Figure 34. Reading from a Single Register with the Read Byte Protocol	90
Figure 35. Reading Continuously from Sequential Registers X to N	91
Figure 36. Engaging HS Mode	92

LIST OF TABLES

Table 1. Regulator Summary	33
Table 2. Variants Table	34
Table 3. OTP Options Table	34
Table 4. GPIO Mode	42
Table 5. Enabling/Disabling SBB2 while GPIO1 is in Alternate Mode	42
Table 6. On/Off Controller Transition/State	44
Table 7. Watchdog Timer Factory-Programmed Safety Options	52
Table 8. Charger Quick Symbol Reference Guide	53
Table 9. Input Current Limit Factory Options	55
Table 10. Trip Temperatures vs. Trip Voltages for Different NTC β	63
Table 11. Example R_S and R_P Correcting Values for NTC β Above 3380K	64
Table 12. NTC Thermistors	65
Table 13. AMUX Signal Transfer Functions	65
Table 14. Battery Current Direction Decode	66
Table 15. SIMO Available Output Current for Common Applications	71
Table 16. Example Inductors	72
Table 17. Design Requirements	73
Table 18. Summary of Design for Component Selection Example	75
Table 19. Summary of Design with Lower Input Voltage	76
Table 20. Switching Frequency Control	76
Table 21. I ² C Slave Address Options	85

Absolute Maximum Ratings

nIRQ, nRST to GND	-0.3V to $V_{SYS} + 0.3V$	IN_SBB to PGND	-0.3V to +6.0V
nEN to GND (Note 1)	-0.3V to $V_{CCINT} + 0.3V$	LXA Continuous Current (Note 3)	1.2A _{RMS}
SCL, SDA, GPIO to GND	-0.3V to $V_{IO} + 0.3V$	LXB Continuous Current (Note 3)	1.2A _{RMS}
CHGIN to GND	-0.3V to +30.0V	SBB0, SBB1, SBB2 to PGND	-0.3V to +6.0V
SYS, BATT to GND	-0.3V to +6.0V	BST to IN_SBB	-0.3V to +6.0V
SYS to IN_SBB	-0.3V to +0.3V	BST to LXB	-0.3V to +6.0V
VL to GND	-0.3V to +6.0V	SBB0, SBB1, SBB2 Short-Circuit Duration	Continuous
AMUX, THM, TBIAS to GND	-0.3V to +6.0V	PGND to GND	-0.3V to +0.3V
nIRQ, nRST, SDA, AMUX, GPIO Continuous Current	±20mA	Operating Temperature Range	-40°C to +85°C
CHGIN Continuous Current	1.2A _{RMS}	Junction Temperature	+150°C
SYS Continuous Current	1.2A _{RMS}	Storage Temperature Range	-65°C to +150°C
BATT Continuous Current (Note 2)	1.2A _{RMS}	Soldering Temperature (reflow)	+260°C
LDO0, LDO1 to GND	-0.3V to $V_{IN_LDO} + 0.3V$	Continuous Power Dissipation (Multilayer Board, $T_A = +70^\circ\text{C}$, derate 20.4mW/°C above +70°C)	1632mW
IN_LDO0, IN_LDO1, V_{IO} to GND	-0.3V to $V_{SYS} + 0.3V$		

Note 1: V_{CCINT} is internally connected to either BATT or VL. See the [nEN Internal Pullup Resistors to \$V_{CCINT}\$](#) section for more details.

Note 2: Do not repeatedly hot-plug a source to the BATT terminal at a rate greater than 10Hz. Hot plugging low impedance sources results in an ~8A momentary (~2μs) current spike.

Note 3: Do not externally bias LXA or LXB. LXA has internal clamping diodes to PGND and IN_SBB. LXB has an internal low-side clamping diode to PGND and an internal high-side clamping diode that dynamically connects to a selected SIMO output. It is normal for these diodes to briefly conduct during switching events. When the SIMO regulator is disabled, the LXB to PGND absolute maximum voltage is -0.3V to $V_{SBB0} + 0.3V$.

Stresses beyond those listed under "Absolute Maximum Ratings" may cause permanent damage to the device. These are stress ratings only, and functional operation of the device at these or any other conditions beyond those indicated in the operational sections of the specifications is not implied. Exposure to absolute maximum rating conditions for extended periods may affect device reliability.

Package Information

WLP

Package Code	N302C2+1
Outline Number	21-100307
Land Pattern Number	Refer to Application Note 1891
Thermal Resistance, Four-Layer Board:	
Junction to Ambient (θ_{JA})	49°C/W (2s2p board)

For the latest package outline information and land patterns (footprints), go to www.maximintegrated.com/packages. Note that a "+", "#", or "-" in the package code indicates RoHS status only. Package drawings may show a different suffix character, but the drawing pertains to the package regardless of RoHS status.

Package thermal resistances were obtained using the method described in JEDEC specification JESD51-7, using a four-layer board. For detailed information on package thermal considerations, refer to www.maximintegrated.com/thermal-tutorial.

Electrical Characteristics

($V_{CHGIN} = 0V$, $V_{SYS} = V_{BATT} = V_{IN_SBB} = V_{IN_LDOx} = 3.7V$, $V_{IO} = 1.8V$, limits are 100% production tested at $T_A = +25^\circ C$. Limits over the operating temperature range ($T_A = -40^\circ C$ to $+85^\circ C$) are guaranteed by design and characterization, unless otherwise noted.)

PARAMETER	SYMBOL	CONDITIONS		MIN	TYP	MAX	UNITS
Operating Voltage Range	V_{SYS}			2.7		5.5	V
Shutdown Supply Current	I_{SHDN}	Current measured into BATT and SYS and IN_SBB and IN_LDOx, all resources are off (LDO0, LDO1, SBB0, SBB1, SBB2), $T_A = +25^\circ C$	Main bias is off (CNFG_GLBL.SBIA_EN = 0); this is the standby state		0.3	1	μA
			Main bias is on in low-power mode (CNFG_GLBL.SBIA_EN = 1, CNFG_GLBL.SBIA_LPM = 1)		1		
			Main bias is on in normal-power mode (CNFG_GLBL.SBIA_EN = 1, CNFG_GLBL.SBIA_LPM = 0)		28		
Main Bias Quiescent Current	I_Q	Main bias is in normal-power mode (CNFG_GLBL.SBIA_LPM = 0)			28		μA
Quiescent Supply Current	I_Q	Current measured into BATT and SYS and IN_SBB and IN_LDOx; LDO0, LDO1, SBB0, SBB1, SBB2 are enabled with no load watchdog timer disabled	Main bias is in low-power mode (CNFG_GLBL.SBIA_LPM = 1)		6	13	μA
BATT Factory-Ship Mode Current	$I_{BATT-FSM}$	Factory-ship mode (BATT to SYS switch open), $T_A = +25^\circ C$, $V_{BATT} = 3.7V$, $V_{SYS} = V_{INLDO0} = V_{INLDO1} = 0V$			0.2	1	μA

Electrical Characteristics—Global Resources

($V_{SYS} = 3.7V$, limits are 100% production tested at $T_A = +25^\circ C$, limits over the operating temperature range ($T_A = -40^\circ C$ to $+85^\circ C$) are guaranteed by design and characterization, unless otherwise noted.)

PARAMETER	SYMBOL	CONDITIONS	MIN	TYP	MAX	UNITS
GENERAL CHARACTERISTICS						
Main Bias Enable Time	t_{SBIA_EN}			0.5		ms
VOLTAGE MONITORS / POWER-ON RESET (POR)						
POR Threshold	V_{POR}	V_{SYS} falling	1.6	1.9	2.1	V
POR Threshold Hysteresis				100		mV

Electrical Characteristics—Global Resources (continued)

($V_{SYS} = 3.7V$, limits are 100% production tested at $T_A = +25^\circ C$, limits over the operating temperature range ($T_A = -40^\circ C$ to $+85^\circ C$) are guaranteed by design and characterization, unless otherwise noted.)

PARAMETER	SYMBOL	CONDITIONS	MIN	TYP	MAX	UNITS	
VOLTAGE MONITORS / UNDERVOLTAGE LOCKOUT (UVLO)							
UVLO Threshold	$V_{SYSUVLO}$	V_{SYS} falling, UVLO_F[3:0] = 0xA (Note 5)	2.5	2.6	2.7	V	
		V_{SYS} falling, UVLO_F[3:0] = 0xF (Note 5)	2.75	2.85	2.95		
UVLO Threshold Hysteresis	$V_{SYSUVLO_HYS}$	UVLO_H[3:0] = 0x5 (Note 5)		300		mV	
VOLTAGE MONITORS / OVERVOLTAGE LOCKOUT (OVLO)							
OVLO Threshold	$V_{SYSOVLO}$	V_{SYS} rising	5.70	5.85	6.00	V	
THERMAL MONITORS							
Overtemperature-Lockout Threshold	T_{OTLO}	T_J rising		165		$^\circ C$	
Thermal Alarm Temperature 1	T_{JAL1}	T_J rising		80		$^\circ C$	
Thermal Alarm Temperature 2	T_{JAL2}	T_J rising		100		$^\circ C$	
Thermal Alarm Temperature Hysteresis				15		$^\circ C$	
ENABLE INPUT (nEN)							
nEN Input Leakage Current	I_{nEN_LKG}	$V_{nEN} = V_{SYS} = 5.5V$	$T_A = +25^\circ C$	-1	± 0.001	+1	μA
			$T_A = +85^\circ C$		± 0.01		
nEN Input Falling Threshold	$V_{TH_nEN_F}$	nEN Falling	$V_{CCINT} - 1.4$	$V_{CCINT} - 1.0$		V	
nEN Input Rising Threshold	$V_{TH_nEN_R}$	nEN Rising		$V_{CCINT} - 0.9$	$V_{CCINT} - 0.6$	V	
V_{CC} Internal	V_{CCINT}	(Note 4)	$V_{CHGIN} = 0V$, battery is present (V_{BATT} is valid)	V_{BATT}		V	
			$V_{CHGIN} = 5V$, not suspended (CNFG_CHG_G.U SBS = 0)	V_L			
Debounce Time	t_{DBNC_nEN}	CNFG_GLBL.DBEN_nEN = 0	500		μs		
		CNFG_GLBL.DBEN_nEN = 1	30		ms		
Manual Reset Time	t_{MRST}	CNFG_GLBL.T_MRT = 1	14	16	20	s	
		CNFG_GLBL.T_MRT = 0	7	8	10.5		
nEN Internal Pullup	R_{nEN_PU}	Pullup to V_{CCINT}	PU_DIS = 0	200		k Ω	
			PU_DIS = 1	10000			
OPEN-DRAIN INTERRUPT OUTPUT (nIRQ)							
Output Voltage Low	V_{OL}	$I_{SINK} = 2mA$			0.4	V	
Output Falling Edge Time	t_{f_nIRQ}	$C_{IRQ} = 25pF$			2	ns	

Electrical Characteristics—Global Resources (continued)

($V_{SYS} = 3.7V$, limits are 100% production tested at $T_A = +25^\circ C$, limits over the operating temperature range ($T_A = -40^\circ C$ to $+85^\circ C$) are guaranteed by design and characterization, unless otherwise noted.)

PARAMETER	SYMBOL	CONDITIONS		MIN	TYP	MAX	UNITS
Leakage Current	I_{nIRQ_LKG}	$V_{SYS} = V_{IO} = 5.5V$ nIRQ is high impedance (no interrupts) $V_{nIRQ} = 0V$ and 5.5V	$T_A = +25^\circ C$	-1	± 0.001	+1	μA
			$T_A = +85^\circ C$			± 0.01	
OPEN-DRAIN RESET OUTPUT (nRST)							
Output Voltage Low	V_{OL}	$I_{SINK} = 2mA$				0.4	V
Output Falling Edge Time	t_{f_nRST}	$C_{RST} = 25pF$			2		ns
nRST Deassert Delay Time	t_{RSTODD}	See Figure 10 and Figure 11 for more information			5.12		ms
nRST Assert Delay Time	t_{RSTOAD}				10.24		ms
Leakage Current	I_{nRST_LKG}	$V_{SYS} = V_{IO} = 5.5V$ nRST is high impedance (no reset) $V_{nRST} = 0V$ and 5.5V	$T_A = +25^\circ C$	-1	± 0.001	+1	μA
			$T_A = +85^\circ C$			± 0.01	
GENERAL PURPOSE INPUT/OUTPUT (GPIO)							
Input Voltage Low	V_{IL}	$V_{IO} = 1.8V$				$0.3 \times V_{IO}$	V
Input Voltage High	V_{IH}	$V_{IO} = 1.8V$		$0.7 \times V_{IO}$			V
Input Leakage Current	I_{GPI_LKG}	CNFG_GPIOx.DIR = 1 $V_{IO} = 5.5V$ $V_{GPIO} = 0V$ and 5.5V	$T_A = +25^\circ C$	-1	± 0.001	+1	μA
			$T_A = +85^\circ C$			± 0.01	
Output Voltage Low	V_{OL}	$I_{SINK} = 2mA$				0.4	V
Output Voltage High	V_{OH}	$I_{SOURCE} = 1mA$		$0.8 \times V_{IO}$			V
Input Debounce Time	t_{DBNC_GPI}	CNFG_GPIOx.DBEN_GPI = 1			30		ms
Output Falling Edge Time	t_{f_GPIO}	$C_{GPIO} = 25pF$			3		ns
Output Rising Edge Time	t_{r_GPIO}	$C_{GPIO} = 25pF$			3		ns
FLEXIBLE POWER SEQUENCER							
FPS Startup Delay	t_{FPS_DLY}				1.43		ms
Power-Up Event Periods	t_{EN}	See Figure 9			1.28		ms
Power-Down Event Periods	t_{DIS}	See Figure 9			2.56		ms

Note 4: See the [nEN Internal Pullup Resistors to \$V_{CCINT}\$](#) section for more details.

Note 5: Programmed at Maxim's factory.

Electrical Characteristics—Smart Power Selector Charger

($V_{CHGIN} = 5.0V$, $V_{SYS} = 4.5V$, $V_{BATT} = 4.2V$, limits are 100% production tested at $T_A = +25^\circ C$, limits over the operating temperature range ($T_A = -40^\circ C$ to $+85^\circ C$) are guaranteed by design and characterization, unless otherwise noted.)

PARAMETER	SYMBOL	CONDITIONS	MIN	TYP	MAX	UNITS
DC INPUT						
CHGIN Valid Voltage Range	V_{CHGIN}	Initial CHGIN voltage before enabling charging	4.10		7.25	V
CHGIN Standoff Voltage Range	$V_{STANDOFF}$	DC rising		28		V
CHGIN Overvoltage Threshold	V_{CHGIN_OVP}	DC rising	7.25	7.50	7.75	V
CHGIN Overvoltage Hysteresis				100		mV
CHGIN Undervoltage Lockout	V_{CHGIN_UVLO}	DC rising	3.9	4.0	4.1	V
CHGIN Undervoltage-Lockout Hysteresis				500		mV
Input Current-Limit Range	$I_{CHGIN-LIM}$	$V_{SYS} = V_{SYS-REG} - 100mV$, programmable in 95mA steps	95		475	mA
Input Current-Limit Accuracy		$I_{CHGIN-LIM} = 95mA$, $V_{SYS} = V_{SYS-REG} - 100mV$	90	95	100	mA
		$I_{CHGIN-LIM} = 475mA$, $V_{SYS} = V_{SYS-REG} - 100mV$		475	500	
Minimum Input Voltage Regulation Range	$V_{CHGIN-MIN}$	V_{CHGIN} falling due to loading conditions and/or high-impedance charge source, programmable in 100mV increments with CNFG_CHG_B.VCHGIN_MIN[2:0]	4.0		4.7	V
Minimum Input Voltage Regulation Accuracy		$V_{CHGIN-MIN} = 4.5V$ (CNFG_CHG_B.VCHGIN_MIN[2:0] = 0b101), I_{CHGIN} reduced by 10%	4.32	4.50	4.68	V
Charger Input Debounce Timer	$t_{CHGIN-DB}$	$V_{CHGIN} = 5V$, time before CHGIN is allowed to deliver current to SYS or BATT	100	120	140	ms
SUPPLY AND QUIESCENT CURRENTS						
CHGIN Supply Current	I_{CHGIN}	$V_{CHGIN} = 5V$, charger is not in USB suspend (CNFG_CHG_G.USBS = 0), charging is finished (STAT_CHG_B.CHG_DTLS[3:0] indicates done), $I_{SYS} = 0mA$		1.0	1.8	mA
		$V_{CHGIN} = 0V$ to 1V, $V_{BATT} = 3.3V$, $I_{SYS} = 0mA$			50	μA
CHGIN Suspend Supply Current	$I_{CHGIN-SUS}$	$V_{CHGIN} = 5V$, charger in USB suspend (CNFG_CHG_G.USBS = 1)			50	μA
BATT Bias Current	$I_{BATT-BIAS}$	$V_{CHGIN} = 5V$, charger is not in USB suspend (CNFG_CHG_G.USBS = 0), charging is finished (STAT_CHG_B.CHG_DTLS[3:0] indicates done), $I_{SYS} = 0mA$		5		μA
PREQUALIFICATION						
Charge Current Soft-Start Slew Time		Zero to full-scale		1		ms

Electrical Characteristics—Smart Power Selector Charger (continued)

($V_{CHGIN} = 5.0V$, $V_{SYS} = 4.5V$, $V_{BATT} = 4.2V$, limits are 100% production tested at $T_A = +25^\circ C$, limits over the operating temperature range ($T_A = -40^\circ C$ to $+85^\circ C$) are guaranteed by design and characterization, unless otherwise noted.)

PARAMETER	SYMBOL	CONDITIONS		MIN	TYP	MAX	UNITS
Prequalification Voltage Threshold Range	V_{PQ}	Programmable in 100mV steps with CNFG_CHG_C.CHG_PQ[2:0]		2.3		3.0	V
Prequalification Voltage Threshold Accuracy		$V_{PQ} = 3.0V$		-3		+3	%
Prequalification Mode Charge Current	I_{PQ}	$V_{BATT} = 2.5V$ $V_{PQ} = 3.0V$ Expressed as a percentage of $I_{FAST-CHG}$	CNFG_CHG_B.I_P Q = 0		10		%
			CNFG_CHG_B.I_P Q = 1		20		
Prequalification Safety Timer	t_{PQ}	$V_{BATT} < V_{PQ} = 3.0V$		27	30	33	minutes
FAST-CHARGE							
Fast-Charge Voltage Range	$V_{FAST-CHG}$	$I_{BATT} = 0mA$, programmable in 25mV steps with CNFG_CHG_G.CHG_CV[5:0]		3.6		4.6	V
Fast-Charge Voltage Accuracy		$I_{BATT} = 0mA$	$V_{FAST-CHG} = 4.3V$, $V_{SYS} = 4.5V$, $T_A = +25^\circ C$	-0.5		+0.5	%
			$V_{FAST-CHG} = 3.6V$ to 4.6V, $V_{SYS} = 4.8V$			1.0	
Fast-Charge Current Range	$I_{FAST-CHG}$	Programmable in 7.5mA steps with CNFG_CHG_E.CHG_CC[5:0]		7.5		300	mA
Fast-Charge Current Accuracy		$T_A = +25^\circ C$, $V_{BATT} = V_{FAST-CHG} - 300mV$	$I_{FAST-CHG} = 15mA$	-1.5		+1.5	%
			$I_{FAST-CHG} = 300mA$	-2.0		+2.0	
Fast-Charge Current Accuracy over Temperature		Across all current settings, $V_{BATT} = V_{FAST-CHG} - 300mV$, $T_A = -40^\circ C$ to $+85^\circ C$		-10		+10	%
Fast-Charge Safety Timer Range	t_{FC}	Programmable in 2 hour increments or disabled with CNFG_CHG_E.T_FAST_CHG[1:0], time measured from prequal. done to timer fault		3		7	hours
Fast-Charge Safety Timer Accuracy		$t_{FC} = 3$ hours		-10		+10	%
Fast-Charge Safety Timer Suspend Threshold		Fast-charge CC mode, fast-charge safety timer paused when charge current drops below this threshold, expressed as a percentage of $I_{FAST-CHG}$			20		%
Junction Temperature Regulation Setting Range	T_{J-REG}	Programmable in $10^\circ C$ steps with CNFG_CHG_D.TJ_REG[2:0]		60		100	$^\circ C$
Junction Temperature Regulation Loop Gain	G_{TJ-REG}	Rate at which $I_{FAST-CHG}/I_{PQ}$ is reduced to maintain T_{J-REG} , expressed as a percentage of $I_{FAST-CHG}/I_{PQ}$ per degree centigrade rise			-5.4		%/ $^\circ C$

Electrical Characteristics—Smart Power Selector Charger (continued)

($V_{CHGIN} = 5.0V$, $V_{SYS} = 4.5V$, $V_{BATT} = 4.2V$, limits are 100% production tested at $T_A = +25^\circ C$, limits over the operating temperature range ($T_A = -40^\circ C$ to $+85^\circ C$) are guaranteed by design and characterization, unless otherwise noted.)

PARAMETER	SYMBOL	CONDITIONS	MIN	TYP	MAX	UNITS	
TERMINATION AND TOP-OFF							
End-of-Charge Termination Current	I_{TERM}	CNFG_CHG_C.I_TERM[1:0] = 0b00 expressed as a percentage of $I_{FAST-CHG}$		5		%	
		CNFG_CHG_C.I_TERM[1:0] = 0b01 expressed as a percentage of $I_{FAST-CHG}$		7.5			
		CNFG_CHG_C.I_TERM[1:0] = 0b10 expressed as a percentage of $I_{FAST-CHG}$	8.5	10	11.5		
		CNFG_CHG_C.I_TERM[1:0] = 0b11 expressed as a percentage of $I_{FAST-CHG}$		15			
Top-Off Timer Range	t_{TO}	$I_{BATT} < I_{TERM}$, programmable in 5 minute steps with CNFG_CHG_C.T_TOPOFF[2:0]	0		35	minutes	
Top-Off Timer Accuracy		$t_{TO} = 10$ minutes	-10		+10	%	
Charge Restart Threshold	$V_{RESTART}$	Charging is finished (STAT_CHG_B.CHG_DTLS[3:0] indicates done) Charging resumes when $V_{BATT} < V_{FAST-CHG} - V_{RESTART}$	65	150		mV	
End-of-Charge Termination Current Accuracy		$I_{FAST-CHG} = 15mA$, $I_{TERM} = 1.5mA$ (10% of $I_{FAST-CHG}$), $T_A = +25^\circ C$	1.35	1.5	1.65	mA	
		$I_{FAST-CHG} = 300mA$, $I_{TERM} = 30mA$ (10% of $I_{FAST-CHG}$), $T_A = +25^\circ C$	27	30	33		
End-of-Charge Termination Current Glitch Filter				60		μs	
DEVICE ON-RESISTANCE AND LEAKAGE							
BATT to SYS On-Resistance		$V_{BATT} = 3.7V$, $I_{BATT} = 300mA$, $V_{CHGIN} = 0V$, battery is discharging to SYS		100	150	m Ω	
Charger FET Leakage Current		$V_{SYS} = 4.5V$, $V_{BATT} = 0V$, charger disabled	$T_A = +25^\circ C$	0.1	1.0	μA	
			$T_A = +85^\circ C$	1			
CHGIN to SYS On-Resistance		$V_{CHGIN} = 4.65V$, $I_{CHGIN} = 400mA$		600		m Ω	
Input FET Leakage Current		$V_{CHGIN} = 0V$, $V_{SYS} = 4.2V$, body-switched diode reverse biased	$T_A = +25^\circ C$	0.1	1.0	μA	
			$T_A = +85^\circ C$	1			
SYSTEM NODE							
System Voltage Regulation Range	$V_{SYS-REG}$	Programmable in 25mV steps with CNFG_CHG_D.VSYS_REG[4:0]	4.1		4.8	V	
System Voltage Regulation Accuracy	V_{SYS}	$V_{SYS-REG} = 4.5V$, $I_{SYS} = 1mA$	$T_A = +25^\circ C$	4.41	4.50	4.59	V
			$T_A = -40^\circ C$ to $+85^\circ C$	4.365	4.5	4.635	

Electrical Characteristics—Smart Power Selector Charger (continued)

($V_{CHGIN} = 5.0V$, $V_{SYS} = 4.5V$, $V_{BATT} = 4.2V$, limits are 100% production tested at $T_A = +25^\circ C$, limits over the operating temperature range ($T_A = -40^\circ C$ to $+85^\circ C$) are guaranteed by design and characterization, unless otherwise noted.)

PARAMETER	SYMBOL	CONDITIONS	MIN	TYP	MAX	UNITS
Minimum System Voltage Regulation Loop Setpoint	$V_{SYS-MIN}$	$V_{CHGIN} = 5V$, $V_{SYS-REG} = 4.5V$, $V_{SYS} < V_{SYS-REG}$ due to $I_{CHGIN} = I_{CHGIN-LIM}$ (input in current limit), battery charging, I_{BATT} reduced to 50% of $I_{FAST-CHG}$ (minimum system voltage regulation active)	4.34	4.4	4.45	V
Supplement Mode System Voltage Regulation		$I_{SYS} = 150mA$		$V_{BATT} - 0.15V$		V

Electrical Characteristics—Adjustable Thermistor Temperature Monitors

($V_{CHGIN} = 5.0V$, $V_{SYS} = 4.5V$, $V_{BATT} = 4.2V$, limits are 100% production tested at $T_A = +25^\circ C$, limits over the operating temperature range ($T_A = -40^\circ C$ to $+85^\circ C$) are guaranteed by design and characterization, unless otherwise noted.)

PARAMETER	SYMBOL	CONDITIONS	MIN	TYP	MAX	UNITS
JEITA TEMPERATURE MONITORS						
TBIAS Voltage	V_{TBIAS}	$CNFG_CHG_F.THM_EN = 1$, $V_{CHGIN} = 5V$		1.25		V
JEITA Cold Threshold Range	V_{COLD}	Voltage rising threshold, programmable with $CNFG_CHG_A.THM_COLD[1:0]$ in $5^\circ C$ increments when using an NTC $\beta = 3380K$	0.867		1.024	V
JEITA Cool Threshold Range	V_{COOL}	Voltage rising threshold, programmable with $CNFG_CHG_A.THM_COOL[1:0]$ in $5^\circ C$ increments when using an NTC $\beta = 3380K$	0.747		0.923	V
JEITA Warm Threshold Range	V_{WARM}	Voltage falling threshold, programmable with $CNFG_CHG_A.THM_WARM[1:0]$ in $5^\circ C$ increments when using an NTC $\beta = 3380K$	0.367		0.511	V
JEITA Hot Threshold Range	V_{HOT}	Voltage falling threshold, programmable with $CNFG_CHG_A.THM_HOT[1:0]$ in $5^\circ C$ increments when using an NTC $\beta = 3380K$	0.291		0.411	V
Temperature Threshold Accuracy		Voltage threshold accuracy expressed as temperature for an NTC $\beta = 3380K$		± 3		$^\circ C$
Temperature Threshold Hysteresis		Temperature hysteresis set on each voltage threshold for an NTC $\beta = 3380K$		3		$^\circ C$
JEITA Modified Fast-Charge Voltage Range	$V_{FAST-CHG_JEITA}$	$I_{BATT} = 0mA$, programmable in 25mV steps, battery is either cool or warm	3.6		4.6	V
JEITA Modified Fast-Charge Current Range	$I_{FAST-CHG_JEITA}$	Programmable in 7.5mA steps, battery is either cool or warm	7.5		300	mA

Electrical Characteristics—Analog Multiplexer

($V_{CHGIN} = 5.0V$, $V_{SYS} = 4.5V$, $V_{BATT} = 4.2V$, limits are 100% production tested at $T_A = +25^\circ C$, limits over the operating temperature range ($T_A = -40^\circ C$ to $+85^\circ C$) are guaranteed by design and characterization, unless otherwise noted.)

PARAMETER	SYMBOL	CONDITIONS		MIN	TYP	MAX	UNITS
ANALOG MULTIPLEXER							
Full-Scale Voltage	V_{FS}				1.25		V
Channel Switching Time					0.3		μs
Off Leakage Current		$V_{AMUX} = 0V$, AMUX is high impedance	$T_A = +25^\circ C$		1	500	nA
			$T_A = +85^\circ C$		1		μA
CHGIN POWER MEASUREMENT							
CHGIN Current Monitor Gain	$G_{I_{CHGIN}}$	V_{FS} corresponds to maximum $I_{CHGIN-LIM}$ setting			2.632		V/A
CHGIN Voltage Monitor Gain	$G_{V_{CHGIN}}$	V_{FS} corresponds to V_{CHGIN_OVP}			0.167		V/V
BATT AND SYS POWER MEASUREMENT							
Battery Charge Current Monitor Gain	$G_{I_{BATT-CHG}}$	V_{FS} corresponds to 100% of $I_{FAST-CHG}$ setting (CNFG_CHG_E.CHG_CC[5:0])			12.5		mV/%
Charge Current Monitor Accuracy			$I_{FAST-CHG} = 15mA$, $T_A = +25^\circ C$, $V_{BATT} = V_{FAST-CHG} - 300mV$	-3.5		+3.5	%
			$I_{FAST-CHG} = 300mA$, $T_A = +25^\circ C$, $V_{BATT} = V_{FAST-CHG} - 300mV$	-3.5		+3.5	
Charge Current Monitor Accuracy over Temperature		Across all current settings, $V_{BATT} = V_{FAST-CHG} - 300mV$		-10		+10	%
Battery Discharge Monitor Full-Scale Current Range	$I_{DISCHG-SCALE}$	Programmable with CNFG_CHG_I.IMON_DISCHG_SCALE[3:0]		8.2		300	mA
Battery Discharge Current Monitor Accuracy		15mA to 300mA battery discharge current, $I_{DISCHG-SCALE} = 300mA$		-15		+15	%
Battery Discharge Current Monitor Offset		$I_{BATT} = 0mA$		-0.5		+0.8	mA
Battery-Voltage Monitor Gain	$G_{V_{BATT}}$	V_{FS} corresponds to maximum $V_{FAST-CHG}$ setting			0.272		V/V
SYS Voltage Monitor Gain	$G_{V_{SYS}}$	V_{FS} corresponds to maximum $V_{SYS-REG}$ setting			0.26		V/V
THM AND TBIAS VOLTAGE MEASUREMENT							
THM Voltage Monitor Gain	$G_{V_{THM}}$				1		V/V
TBIAS Voltage Monitor Gain	$G_{V_{TBIAS}}$				1		V/V

Electrical Characteristics—SIMO Buck-Boost

($V_{SYS} = 3.7V$, $V_{IN_SBB} = 3.7V$, $C_{SBBx} = 10\mu F$, $L = 1.5\mu H$, limits are 100% production tested at $T_A = +25^\circ C$, limits over the operating temperature range ($T_A = -40^\circ C$ to $+85^\circ C$) are guaranteed by design and characterization, unless otherwise noted.)

PARAMETER	SYMBOL	CONDITIONS	MIN	TYP	MAX	UNITS	
GENERAL CHARACTERISTICS / OUTPUT VOLTAGE RANGE (SBB0)							
Programmable Output Voltage Range			0.8		5.5	V	
Output DAC Bits				7		bits	
Output DAC LSB Size				50		mV	
GENERAL CHARACTERISTICS / OUTPUT VOLTAGE RANGE (SBB1)							
Programmable Output Voltage Range			0.8		5.5	V	
Output DAC Bits				7		bits	
Output DAC LSB Size				50		mV	
GENERAL CHARACTERISTICS / OUTPUT VOLTAGE RANGE (SBB2)							
Programmable Output Voltage Range			0.8		5.5	V	
Output DAC Bits				7		bits	
Output DAC LSB Size				50		mV	
OUTPUT VOLTAGE ACCURACY							
Output Voltage Accuracy		V_{SBBx} falling, threshold where LXA switches high; specified as a percentage of target output voltage	$T_A = +25^\circ C$	-3.0	+3.0	%	
			$T_A = -40^\circ C$ to $+85^\circ C$	-4.55	+4.55		
TIMING CHARACTERISTICS							
Enable Delay		Delay time from the SIMO receiving its first enable signal to when it begins to switch in order to service that output		60		μs	
Soft-Start Slew Rate	dV/dt_{SS}		3.3	5.0	6.6	$mV/\mu s$	
T_{off} Timeout	t_{off_max}	$INT_GLBL1.SBB_TO = 1$		10		μs	
POWER STAGE CHARACTERISTICS							
LXA Leakage Current		SBB0, SBB1, SBB2 are disabled, $V_{IN_SBB} = 5.5V$, $V_{LXA} = 0V$, or $5.5V$	$T_A = +25^\circ C$	-1.0	± 0.1	+1.0	μA
			$T_A = +85^\circ C$		± 1.0		
LXB Leakage Current		SBB0, SBB1, SBB2 are disabled, $V_{IN_SBB} = 5.5V$, $V_{LXA} = 0V$ or $5.5V$, all $V_{SBBx} = 5.5V$	$T_A = +25^\circ C$	-1.0	± 0.1	+1.0	μA
			$T_A = +85^\circ C$		± 1.0		
BST Leakage Current		$V_{IN_SBB} = 5.5V$, $V_{LXB} = 5.5V$, $V_{BST} = 11V$,	$T_A = +25^\circ C$		+0.01	+1.0	μA
			$T_A = +85^\circ C$		+0.1		

Electrical Characteristics—SIMO Buck-Boost (continued)

($V_{SYS} = 3.7V$, $V_{IN_SBB} = 3.7V$, $C_{SBBx} = 10\mu F$, $L = 1.5\mu H$, limits are 100% production tested at $T_A = +25^\circ C$, limits over the operating temperature range ($T_A = -40^\circ C$ to $+85^\circ C$) are guaranteed by design and characterization, unless otherwise noted.)

PARAMETER	SYMBOL	CONDITIONS	MIN	TYP	MAX	UNITS
Disabled Output Leakage Current		SBB0, SBB1, SBB2 are disabled, active-discharge disabled (ADE_SBBx = 0), $V_{SBBx} = 5.5V$, $V_{LXB} = 0V$, $V_{SYS} = V_{IN_SBB} = V_{BST} = 5.5V$, $T_A = +25^\circ C$		+0.1	+1.0	μA
		$T_A = +85^\circ C$		+0.2		
Active Discharge Resistance	R_{AD_SBBx}	SBB0, SBB1, SBB2 are disabled, active discharge enabled (CNFG_SBBx_B.ADE_SBBx = 1)	80	140	260	Ω
CONTROL SCHEME						
Peak Current Limit	I_{P_SBB} (Note 6)	CNFG_SBBx_B.IP_SBBx[1:0] = 0b11	-18%	0.335	+18%	A
		CNFG_SBBx_B.IP_SBBx[1:0] = 0b10	-14%	0.500	+14%	
		CNFG_SBBx_B.IP_SBBx[1:0] = 0b01	-8%	0.750	+8%	
		CNFG_SBBx_B.IP_SBBx[1:0] = 0b00	-7%	1.000	+7%	

Note 6: Typical values align with bench observations using the stated conditions with an inductor. Minimum and maximum values are tested in production with DC currents without an inductor. See the *Typical Operating Characteristics* SIMO switching waveforms to gain more insight on this specification.

Electrical Characteristics—Low Dropout Linear Regulator (LDO)/Load Switch (LSW)

($V_{SYS} = 3.7V$, limits are 100% production tested at $T_A = +25^\circ C$, limits over the operating temperature range ($T_A = -40^\circ C$ to $+85^\circ C$) are guaranteed by design and characterization, unless otherwise noted.)

PARAMETER	SYMBOL	CONDITIONS	MIN	TYP	MAX	UNITS
LDO0/1						
Input Voltage Range	V_{IN_LDOx}	LDO mode	1.71		5.5	V
		Switch mode	1.3		5.5	
Quiescent Supply Current	I_{IN_LDOx}	$I_{OUT_LDOx} = 0$		1.4	2.1	μA
		$I_{OUT_LDOx} = 0$, switch mode		0.5	1	
Quiescent Supply Current In Dropout	$I_{IN_DRP_LDOx}$	$I_{OUT_LDOx} = 0$, $V_{IN_LDOx} = 2.9V$, $V_{LDOx} = 3V$		2.1	4.6	μA
Maximum Output Current	I_{OUT_LDOx}	$V_{IN_LDOx} > 1.8V$	100			mA
		$V_{IN_LDOx} = 1.8V$ or lower	50			
Output Voltage	V_{OUT_LDOx}		0.8		3.975	V
Output Accuracy		$V_{IN_LDOx} = (V_{OUT_LDOx} + 0.5V)$ or higher, $I_{OUT_LDOx} = 1mA$	-3.1		+3.1	%
Dropout Voltage	V_{DRP_LDOx}	$V_{IN_LDOx} = 3V$, LDOx programmed to 3V, $I_{OUT_LDOx} = 100mA$			100	mV
Line Regulation		$V_{IN_LDOx} = (V_{OUT_LDOx} + 0.5V)$ to 5.5V	-0.5		+0.5	%/V
Load Regulation		$V_{IN_LDOx} = 1.8V$ or higher, $I_{OUT_LDOx} = 100\mu A$ to 100mA		0.001	0.005	%/mA

**Electrical Characteristics—Low Dropout Linear Regulator (LDO)/Load Switch (LSW)
(continued)**

($V_{SYS} = 3.7V$, limits are 100% production tested at $T_A = +25^\circ C$, limits over the operating temperature range ($T_A = -40^\circ C$ to $+85^\circ C$) are guaranteed by design and characterization, unless otherwise noted.)

PARAMETER	SYMBOL	CONDITIONS	MIN	TYP	MAX	UNITS
Line Transient		$V_{IN_LDOx} = 4V$ to $5V$, 200ns rise time		± 35		mV
		$V_{IN_LDOx} = 4V$ to $5V$, 1 μs rise time		± 25		
Load Transient		$I_{OUT_LDOx} = 100\mu A$ to $10mA$, 200ns rise time		100		mV
		$I_{OUT_LDOx} = 100\mu A$ to $100mA$, 200ns rise time		200		
Active Discharge Resistance	R_{AD_LDOx}		42	80	200	Ω
Switch Mode On-Resistance	R_{ON_LDOx}	$V_{IN_LDOx} = 2.7V$, $I_{OUT_LDOx} = 100mA$			0.8	Ω
		$V_{IN_LDOx} = 1.8V$, $I_{OUT_LDOx} = 50mA$			1	
		$V_{IN_LDOx} = 1.3V$, $I_{OUT_LDOx} = 5mA$			3	
Slew Rate		$I_{OUT_LDOx} = 0mA$, time from 10% to 90% of final register value		1.4		V/ms
		$I_{OUT_LDOx} = 0mA$, time from 10% to 90% of final register value, switch mode		1.4		
Short Circuit Current Limit		$V_{IN_LDOx} = 2.7V$, $V_{OUT_LDOx} = GND$	170	380	620	mA
		$V_{IN_LDOx} = 2.7V$, $V_{OUT_LDOx} = 2.55V$, switch mode	170	370		
Output Noise		10Hz to 100kHz, $V_{IN_LDOx} = 5V$, $V_{OUT_LDOx} = 3.3V$		150		μV_{RMS}
		10Hz to 100kHz, $V_{IN_LDOx} = 5V$, $V_{OUT_LDOx} = 2.5V$		125		
		10Hz to 100kHz, $V_{IN_LDOx} = 5V$, $V_{OUT_LDOx} = 1.2V$		90		
		10Hz to 100kHz, $V_{IN_LDOx} = 5V$, $V_{OUT_LDOx} = 0.9V$		80		
Output DAC Bits			7			bits
Output DAC LSB Size				25		mV
Fault Threshold	V_{LDOx_F}	$INT_GLBL1.LDOx_F = 1$, expressed as a percentage of V_{LDOx}	Falling	87.5		%

Electrical Characteristics— I^2C Serial Communication

($V_{SYS} = 3.7V$, $V_{IO} = 1.8V$, limits are 100% production tested at $T_A = +25^\circ C$, limits over the operating temperature range ($T_A = -40^\circ C$ to $+85^\circ C$) are guaranteed by design and characterization, unless otherwise noted.)

PARAMETER	SYMBOL	CONDITIONS	MIN	TYP	MAX	UNITS
POWER SUPPLY						
V_{IO} Voltage Range	V_{IO}		1.7	1.8	3.6	V

Electrical Characteristics— I^2C Serial Communication (continued)

($V_{SYS} = 3.7V$, $V_{IO} = 1.8V$, limits are 100% production tested at $T_A = +25^\circ C$, limits over the operating temperature range ($T_A = -40^\circ C$ to $+85^\circ C$) are guaranteed by design and characterization, unless otherwise noted.)

PARAMETER	SYMBOL	CONDITIONS	MIN	TYP	MAX	UNITS
V_{IO} Bias Current		$V_{IO} = 3.6V$, $V_{SDA} = V_{SCL} = 0V$ or $3.6V$, $T_A = +25^\circ C$	-1	0	+1	μA
		$V_{IO} = 1.7V$, $V_{SDA} = V_{SCL} = 0V$ or $1.7V$	-1	0	+1	
SDA AND SCL I/O STAGE						
SCL, SDA Input High Voltage	V_{IH}	$V_{IO} = 1.7V$ to $3.6V$	$0.7 \times V_{IO}$			V
SCL, SDA Input Low Voltage	V_{IL}	$V_{IO} = 1.7V$ to $3.6V$	$0.3 \times V_{IO}$			V
SCL, SDA Input Hysteresis	V_{HYS}		$0.05 \times V_{IO}$			V
SCL, SDA Input Leakage Current	I_I	$V_{IO} = 3.6V$, $V_{SCL} = V_{SDA} = 0V$ and $3.6V$	-10		+10	μA
SDA Output Low Voltage	V_{OL}	Sinking 20mA			0.4	V
SCL, SDA Pin Capacitance	C_I			10		pF
Output Fall Time from V_{IH} to V_{IL}	t_{OF} (Note 7)				120	ns
I^2C-COMPATIBLE INTERFACE TIMING (STANDARD, FAST, AND FAST-MODE PLUS) (Note 7)						
Clock Frequency	f_{SCL}		0		1000	kHz
Hold Time REPEATED START Condition	t_{HD_STA}		0.26			μs
SCL Low Period	t_{LOW}		0.5			μs
SCL High Period	t_{HIGH}		0.26			μs
Setup Time REPEATED START Condition	t_{SU_STA}		0.26			μs
Data Hold Time	t_{HD_DAT}		0			μs
Data Setup Time	t_{SU_DAT}		50			ns
Setup Time for STOP Condition	t_{SU_STO}		0.26			μs
Bus Free Time between STOP and START Condition	t_{BUF}		0.5			μs
Pulse Width of Suppressed Spikes	t_{SP}	Maximum pulse width of spikes that must be suppressed by the input filter		50		ns
I^2C-COMPATIBLE INTERFACE TIMING (HIGH-SPEED MODE, $C_B = 100pF$) (Note 7)						
Clock Frequency	f_{SCL}				3.4	MHz
Setup Time REPEATED START Condition	t_{SU_STA}		160			ns
Hold Time REPEATED START Condition	t_{HD_STA}		160			ns
SCL Low Period	t_{LOW}		160			ns
SCL High Period	t_{HIGH}		60			ns

Electrical Characteristics—^I2C Serial Communication (continued)

($V_{SYS} = 3.7V$, $V_{IO} = 1.8V$, limits are 100% production tested at $T_A = +25^\circ C$, limits over the operating temperature range ($T_A = -40^\circ C$ to $+85^\circ C$) are guaranteed by design and characterization, unless otherwise noted.)

PARAMETER	SYMBOL	CONDITIONS	MIN	TYP	MAX	UNITS
Data Setup Time	t_{SU_DAT}		10			ns
Data Hold Time	t_{HD_DAT}		0		70	ns
SCL Rise Time	t_{rCL}	$T_A = +25^\circ C$	10		40	ns
Rise Time of SCL Signal after REPEATED START Condition and after Acknowledge Bit	t_{rCL1}	$T_A = +25^\circ C$	10		80	ns
SCL Fall Time	t_{fCL}	$T_A = +25^\circ C$	10		40	ns
SDA Rise Time	t_{rDA}	$T_A = +25^\circ C$	10		80	ns
SDA Fall Time	t_{fDA}	$T_A = +25^\circ C$	10		80	ns
Setup Time for STOP Condition	t_{SU_STO}		160			ns
Bus Capacitance	C_B				100	pF
Pulse Width of Suppressed Spikes	t_{SP}	Maximum pulse width of spikes that must be suppressed by the input filter		10		ns
^I2C-COMPATIBLE INTERFACE TIMING (HIGH-SPEED MODE, $C_B = 400pF$) (Note 7)						
Clock Frequency	f_{SCL}				1.7	MHz
Setup Time REPEATED START Condition	t_{SU_STA}		160			ns
Hold Time REPEATED START Condition	t_{HD_STA}		160			ns
SCL Low Period	t_{LOW}		320			ns
SCL High Period	t_{HIGH}		120			ns
Data Setup Time	t_{SU_DAT}		10			ns
Data Hold Time	t_{HD_DAT}		0		150	ns
SCL Rise Time	t_{rCL}	$T_A = +25^\circ C$	20		80	ns
Rise Time of SCL Signal after REPEATED START Condition and after Acknowledge Bit	t_{rCL1}	$T_A = +25^\circ C$	20		80	ns
SCL Fall Time	t_{fCL}	$T_A = +25^\circ C$	20		80	ns
SDA Rise Time	t_{rDA}	$T_A = +25^\circ C$	20		160	ns
SDA Fall Time	t_{fDA}	$T_A = +25^\circ C$	20		160	ns
Setup Time for STOP Condition	t_{SU_STO}		160			ns
Bus Capacitance	C_B				400	pF
Pulse Width of Suppressed Spikes	t_{SP}	Maximum pulse width of spikes that must be suppressed by the input filter		10		ns

Note 7: Design guidance only. Not production tested.

Typical Operating Characteristics

(Typical Applications Circuit. $V_{CHGIN} = 0V$, $V_{SYS} = V_{IN_SBB} = V_{BATT} = 3.7V$, $V_{IO} = 1.8V$, $T_A = +25^\circ C$, $V_{SBB0} = 1.8V$, $I_{P_SBB0} = 0.5A$, SBB0 in Buck mode, $V_{SBB1} = 1.1V$, $I_{P_SBB1} = 0.5A$, SBB1 in Buck mode, $V_{SBB2} = 3.3V$, $I_{P_SBB2} = 1A$ peak, SBB2 in Buck-Boost mode, unless otherwise noted. Inductor = DFE201612E-2R2M, $2.2\mu H$, $116m\Omega$.)

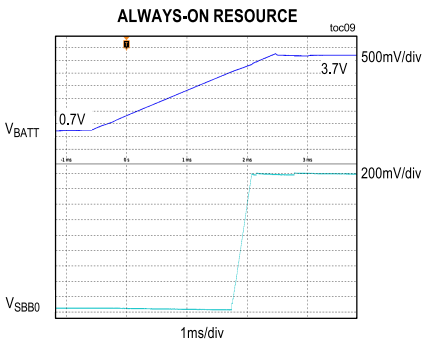
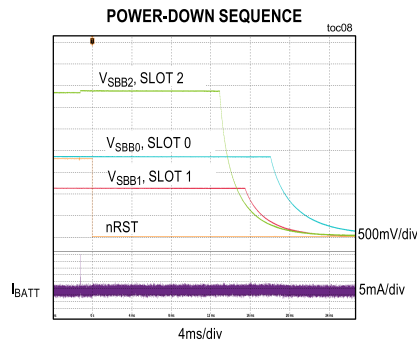
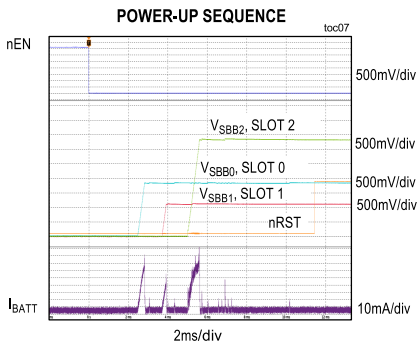
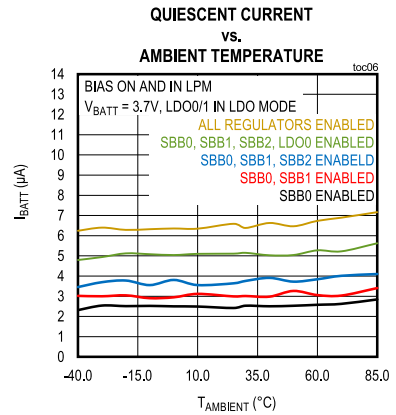
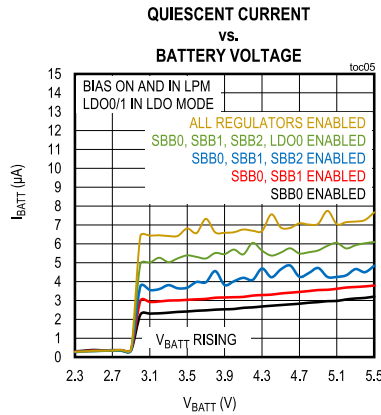
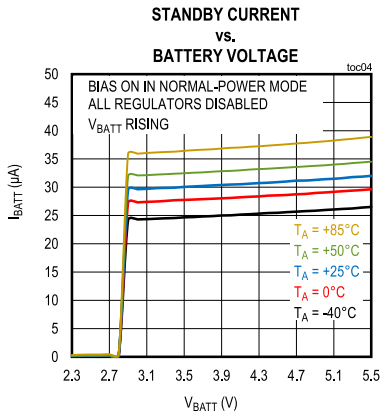
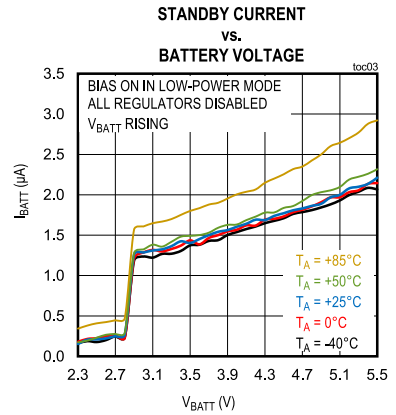
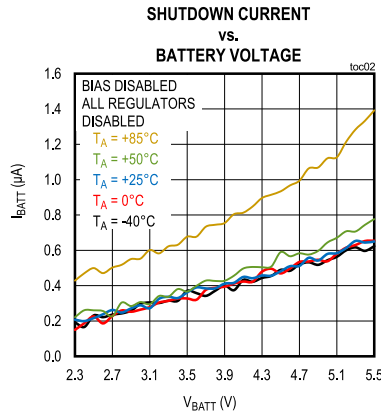
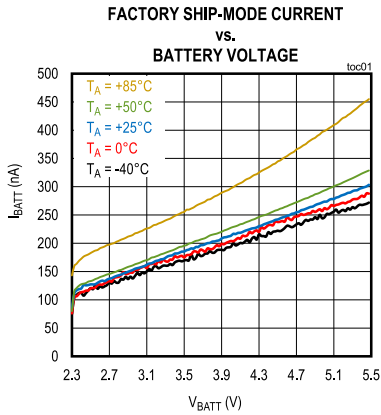

Typical Operating Characteristics (continued)

(Typical Applications Circuit. $V_{CHGIN} = 0V$, $V_{SYS} = V_{IN_SBB} = V_{BATT} = 3.7V$, $V_{IO} = 1.8V$, $T_A = +25^\circ C$, $V_{SBB0} = 1.8V$, $I_{P_SBB0} = 0.5A$, SBB0 in Buck mode, $V_{SBB1} = 1.1V$, $I_{P_SBB1} = 0.5A$, SBB1 in Buck mode, $V_{SBB2} = 3.3V$, $I_{P_SBB2} = 1A$ peak, SBB2 in Buck-Boost mode, unless otherwise noted. Inductor = DFE201612E-2R2M, $2.2\mu H$, $116m\Omega$.)

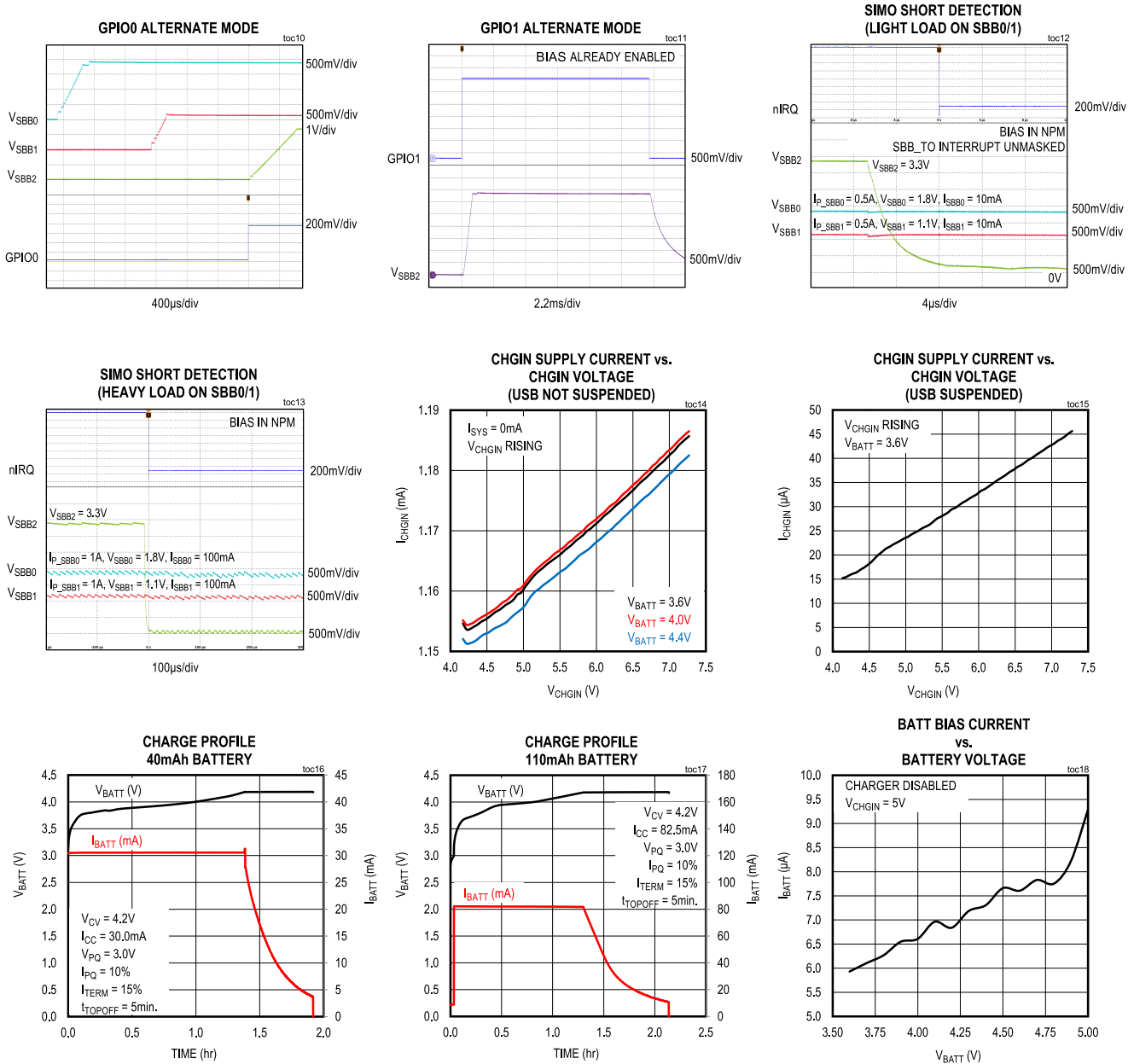

Typical Operating Characteristics (continued)

(Typical Applications Circuit. $V_{CHGIN} = 0V$, $V_{SYS} = V_{IN_SBB} = V_{BATT} = 3.7V$, $V_{IO} = 1.8V$, $T_A = +25^{\circ}C$, $V_{SBB0} = 1.8V$, $I_{P_SBB0} = 0.5A$, SBB0 in Buck mode, $V_{SBB1} = 1.1V$, $I_{P_SBB1} = 0.5A$, SBB1 in Buck mode, $V_{SBB2} = 3.3V$, $I_{P_SBB2} = 1A$ peak, SBB2 in Buck-Boost mode, unless otherwise noted. Inductor = DFE201612E-2R2M, $2.2\mu H$, $116m\Omega$.)

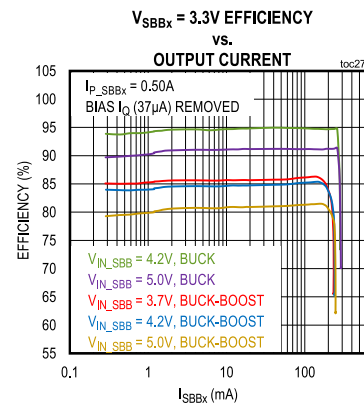
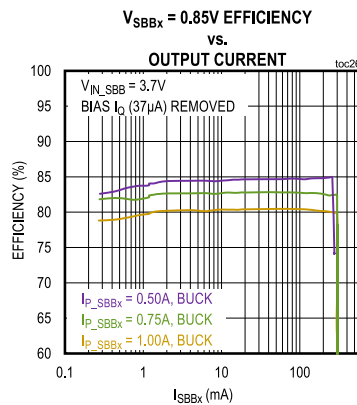
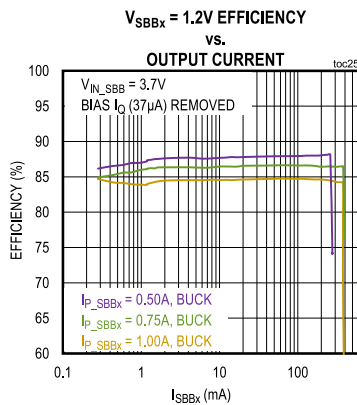
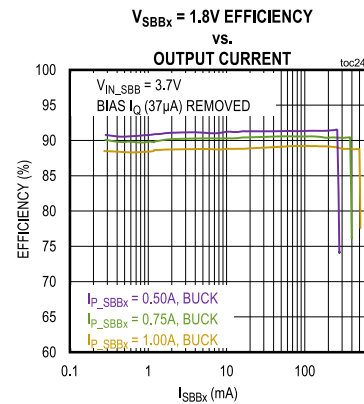
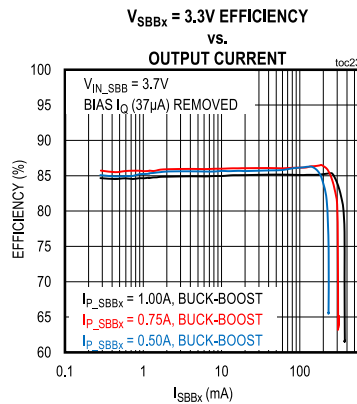
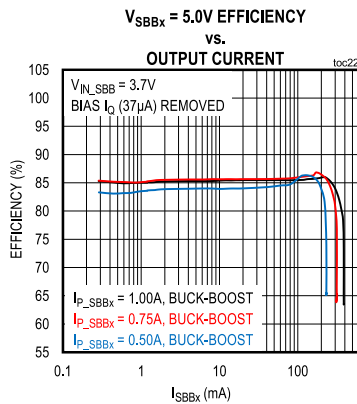
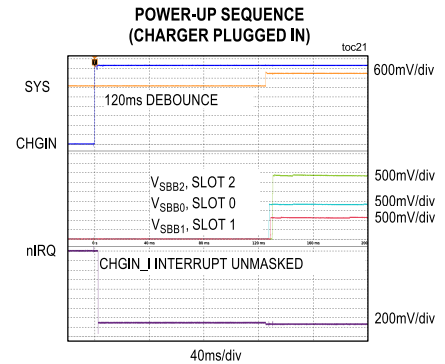
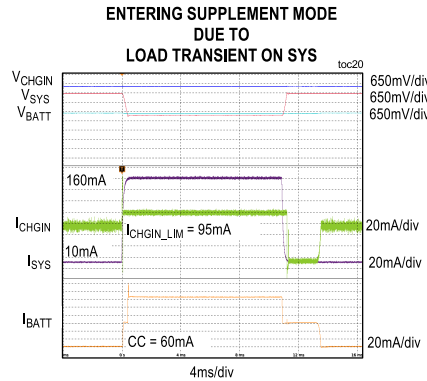
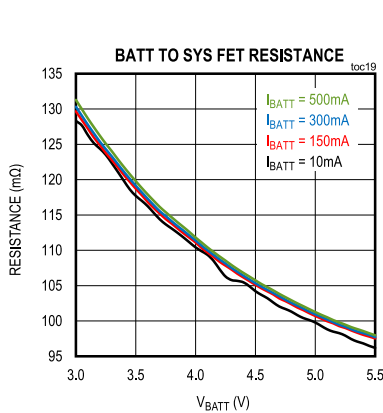

Typical Operating Characteristics (continued)

(Typical Applications Circuit. $V_{CHGIN} = 0V$, $V_{SYS} = V_{IN_SBB} = V_{BATT} = 3.7V$, $V_{IO} = 1.8V$, $T_A = +25^\circ C$, $V_{SBB0} = 1.8V$, $I_{p_SBB0} = 0.5A$, SBB0 in Buck mode, $V_{SBB1} = 1.1V$, $I_{p_SBB1} = 0.5A$, SBB1 in Buck mode, $V_{SBB2} = 3.3V$, $I_{p_SBB2} = 1A$ peak, SBB2 in Buck-Boost mode, unless otherwise noted. Inductor = DFE201612E-2R2M, $2.2\mu H$, $116m\Omega$.)

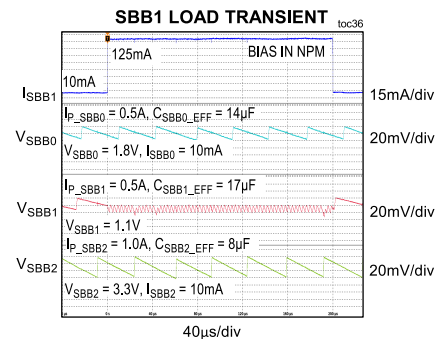
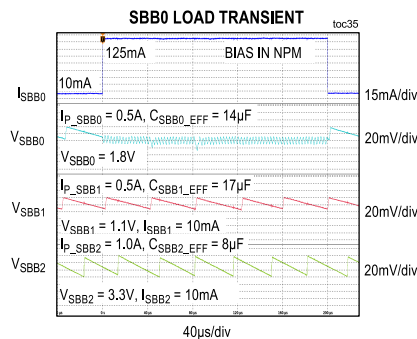
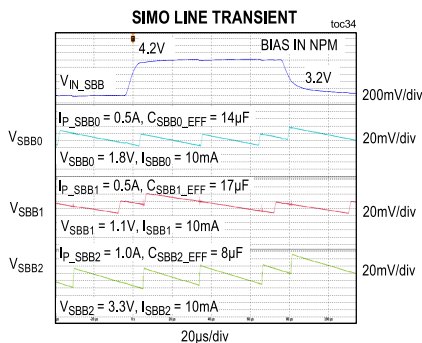
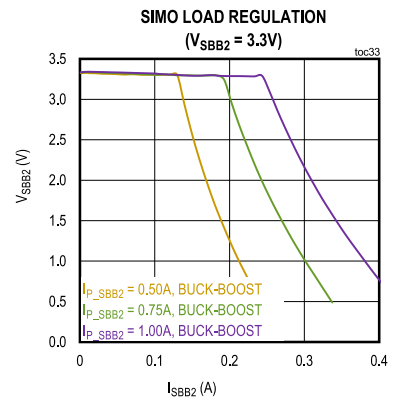
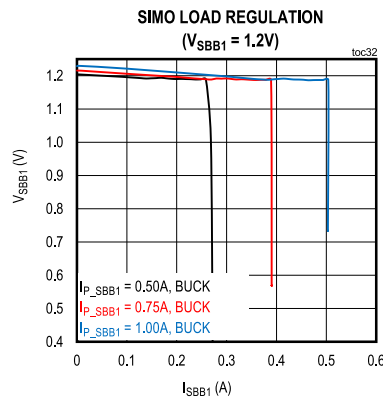
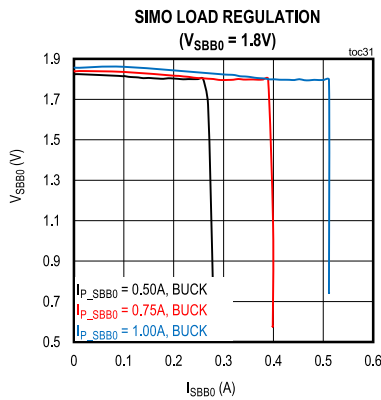
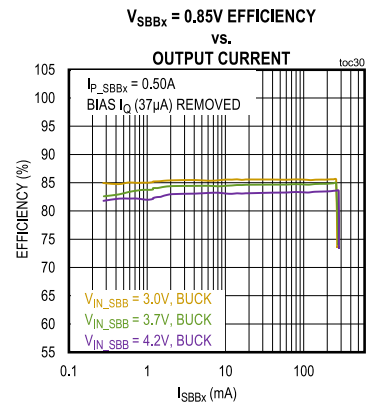
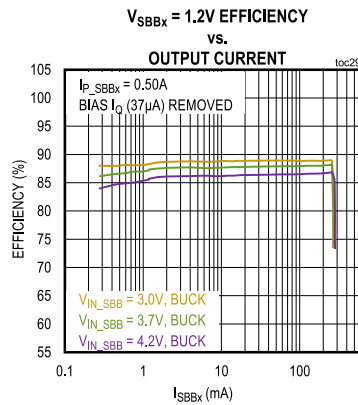
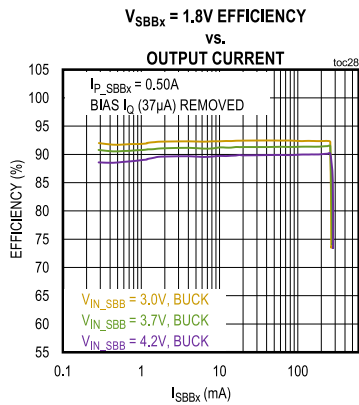

Typical Operating Characteristics (continued)

(Typical Applications Circuit. $V_{CHGIN} = 0V$, $V_{SYS} = V_{IN_SBB} = V_{BATT} = 3.7V$, $V_{IO} = 1.8V$, $T_A = +25^\circ C$, $V_{SBB0} = 1.8V$, $I_{P_SBB0} = 0.5A$, SBB0 in Buck mode, $V_{SBB1} = 1.1V$, $I_{P_SBB1} = 0.5A$, SBB1 in Buck mode, $V_{SBB2} = 3.3V$, $I_{P_SBB2} = 1A$ peak, SBB2 in Buck-Boost mode, unless otherwise noted. Inductor = DFE201612E-2R2M, $2.2\mu H$, $116m\Omega$.)

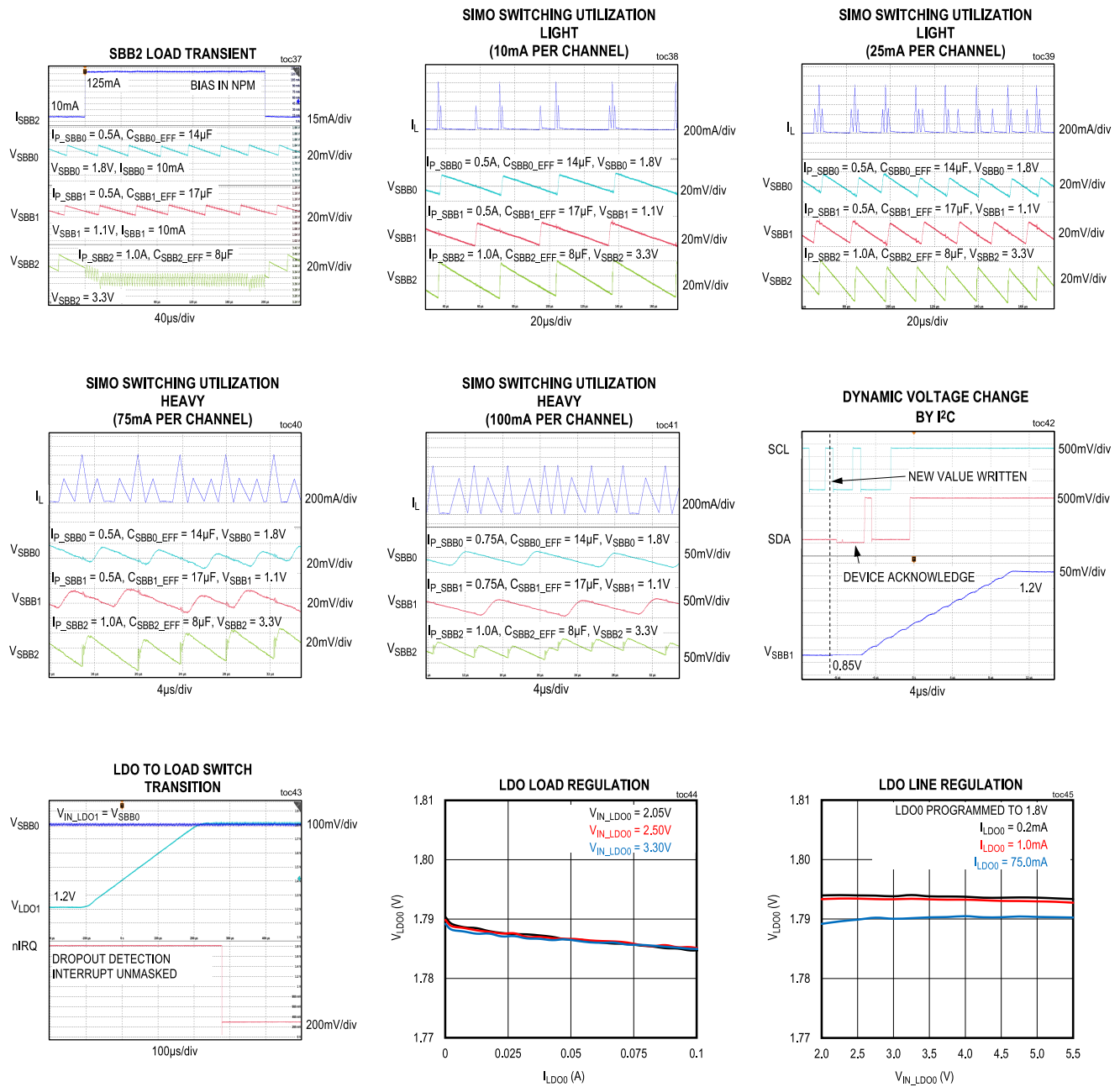

Typical Operating Characteristics (continued)

(Typical Applications Circuit. $V_{CHGIN} = 0V$, $V_{SYS} = V_{IN_SBB} = V_{BATT} = 3.7V$, $V_{IO} = 1.8V$, $T_A = +25^{\circ}C$, $V_{SBB0} = 1.8V$, $I_{P_SBB0} = 0.5A$, SBB0 in Buck mode, $V_{SBB1} = 1.1V$, $I_{P_SBB1} = 0.5A$, SBB1 in Buck mode, $V_{SBB2} = 3.3V$, $I_{P_SBB2} = 1A$ peak, SBB2 in Buck-Boost mode, unless otherwise noted. Inductor = DFE201612E-2R2M, $2.2\mu H$, $116m\Omega$.)

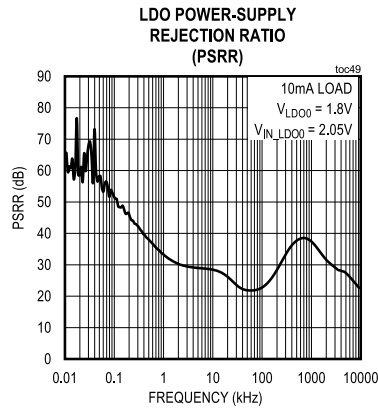
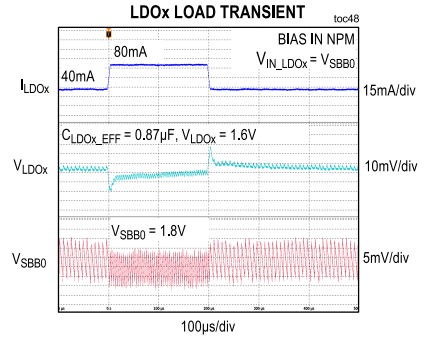
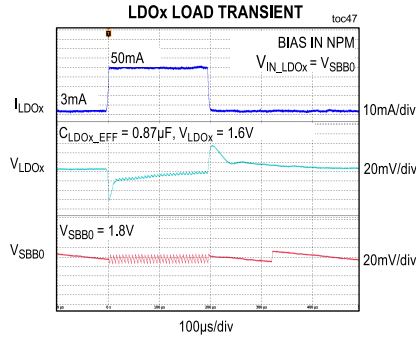
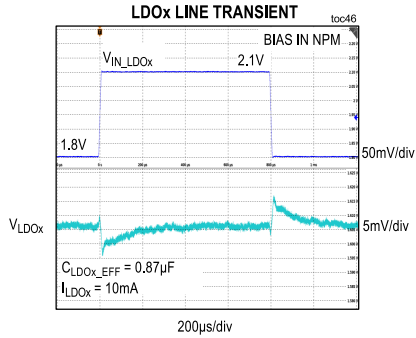

Pin Configurations

MAX77654xENV

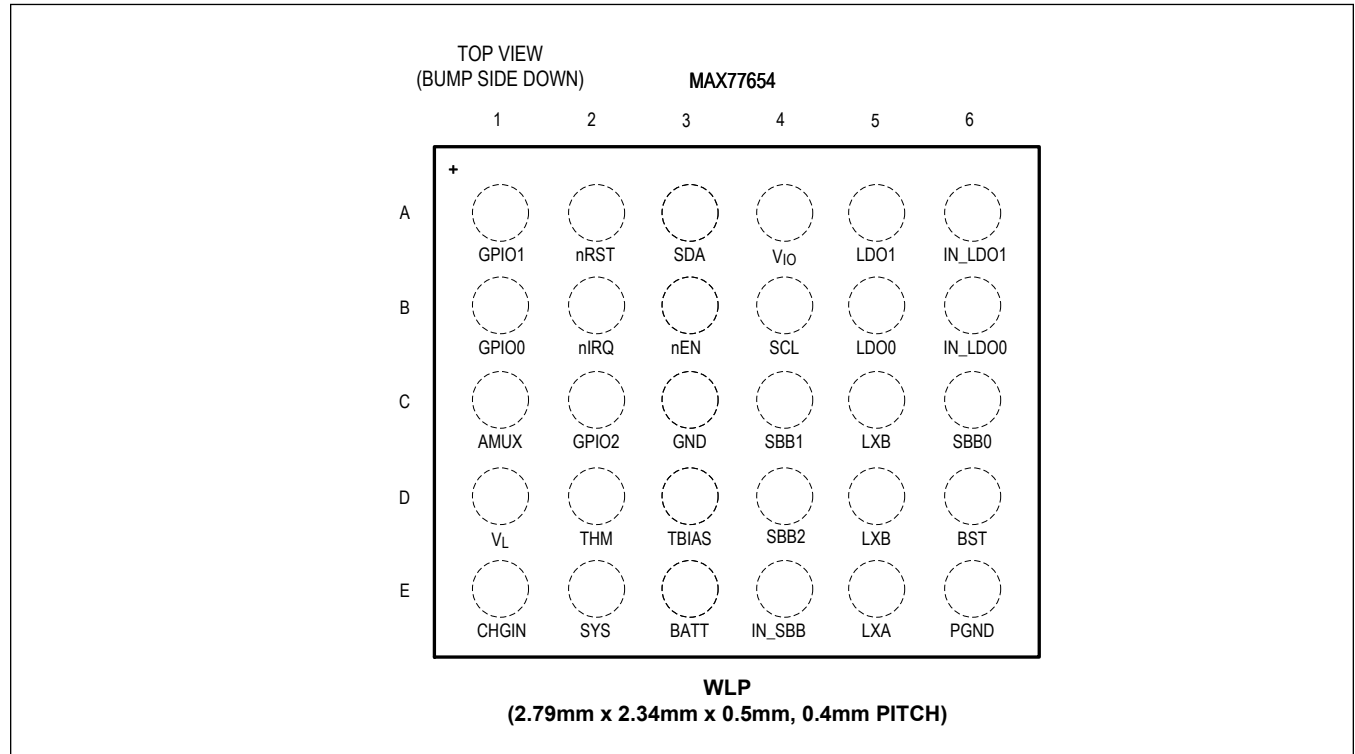

MAX77654

Ultra-Low Power PMIC Featuring Single-Inductor, 3-Output Buck-Boost, 2-LDOs, Power-Path Charger for Small Li+, and Ship Mode

MAX77654xENVN

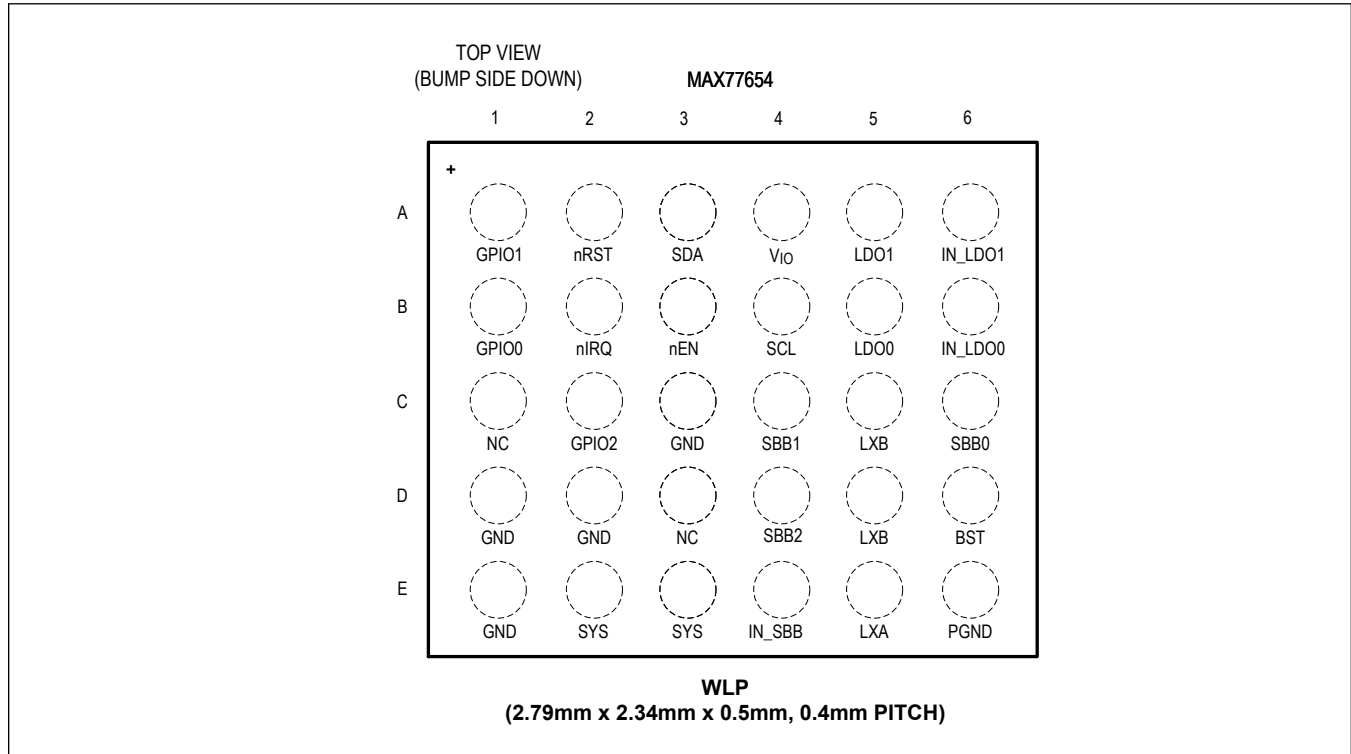

Pin Description

PIN		NAME	FUNCTION	TYPE
MAX77654xE NV	MAX77654xE NVN			
	C1, D3	NC	Not connected.	
TOP LEVEL				
A4	A4	V _{IO}	I ² C Interface and GPIO Driver Power	Power Input
B3	B3	nEN	Active-Low Enable Input. \overline{EN} supports push-button or slide-switch configurations. If not used, leave EN unconnected and use the CNFG_SBBx_B.EN_SBBx[2:0] and CNFG_LDOx_B.EN_LDOx[2:0] bitfields to enable channels. Pulled up internally to V _{CCINT} .	Digital Input
B2	B2	nIRQ	Active-Low, Open-Drain Interrupt Output. Connect a 100kΩ pullup resistor between \overline{IRQ} and a voltage equal to or less than V _{SYS} .	Digital Output
A2	A2	nRST	Active-Low, Open-Drain Reset Output. Connect a 100kΩ pullup resistor between \overline{RST} and a voltage equal to or less than V _{SYS} .	Digital Output
C2	C2	GPIO2	General Purpose Input/Output. The GPIO I/O stage is internally biased with V _{IO}	Digital I/O
A1	A1	GPIO1	General Purpose Input/Output. The GPIO I/O stage is internally biased with V _{IO} .	Digital I/O
B1	B1	GPIO0	General Purpose Input/Output. The GPIO I/O stage is internally biased with V _{IO} .	Digital I/O
B4	B4	SCL	I ² C Clock	Digital Input

Pin Description (continued)

PIN		NAME	FUNCTION	TYPE
MAX77654xE NV	MAX77654xE NVN			
A3	A3	SDA	I ² C Data	Digital I/O
C3	C3, D1, D2, E1	GND	Quiet Ground. Connect GND to PGND, and the low-impedance ground plane of the PCB.	Ground
CHARGER				
E1	—	CHGIN	Charger Input. Connect to a DC charging source. Bypass to GND with a 4.7μF ceramic capacitor.	Power Input
E2	E2, E3	SYS	System Power Output. SYS provides power to the system resources as well as the control logic of the device. Connect to IN_SBB and bypass to GND with a 22μF ceramic capacitor.	Power Output
E3	—	BATT	Li+ Battery Connection. Connect to positive battery terminal. Bypass to GND with a 4.7μF ceramic capacitor.	Power I/O
D1	—	VL	Internal Charger 3V Logic Supply Powered from CHGIN. Bypass to GND with a 1μF ceramic capacitor. Do not load V _L externally.	Power Output
D3	—	TBIAS	Thermistor Bias Supply. Connect a resistor equal to the NTCs room temperature resistance between TBIAS and THM. Do not load TBIAS with any other external circuitry. If not used, leave the pin disconnected.	Analog
D2	—	THM	Thermistor Monitor. Thermally couple an NTC to the battery and connect between THM and GND. If not used, connect THM directly to ground.	Analog Input
C1	—	AMUX	Analog Multiplexer Output. Connect to system ADC to perform conversions on charger power signals.	Analog Output
SIMO BUCK-BOOST				
E4	E4	IN_SBB	SIMO Power Input. Connect IN_SBB to SYS and bypass to PGND with a minimum of 10μF ceramic capacitor as close as possible to the IN_SBB pin.	Power Input
C6	C6	SBB0	SIMO Buck-Boost Output 0. SBB0 is the power output for channel 0 of the SIMO buck-boost. Bypass SBB0 to PGND with a 10μF ceramic capacitor. If not used, see the Unused Outputs section.	Power Output
C4	C4	SBB1	SIMO Buck-Boost Output 1. SBB1 is the power output for channel 1 of the SIMO buck-boost. Bypass SBB1 to PGND with a 10μF ceramic capacitor. If not used, see the Unused Outputs section.	Power Output
D4	D4	SBB2	SIMO Buck-Boost Output 2. SBB2 is the power output for channel 2 of the SIMO buck-boost. Bypass SBB0 to PGND with a 10μF ceramic capacitor. If not used, see the Unused Outputs section.	Power Output
D6	D6	BST	SIMO Power Input for the High-Side Output NMOS Drivers. Connect a 3300pF ceramic capacitor between BST and LXB.	Power Input
D5, C5	D5, C5	LXB	Switching Node B. LXB is driven between PGND and SBBx when SBBx is enabled. LXB is driven to PGND when all SIMO channels are disabled. Connect a 1.5μH inductor between LXA and LXB.	Power Input
E5	E5	LXA	Switching Node A. LXA is driven between PGND and IN_SBB when any SIMO channel is enabled. LXA is driven to PGND when all SIMO channels are disabled. Connect a 1.5μH inductor between LXA and LXB.	Power I/O
E6	E6	PGND	Power ground for the SIMO low-side FETs. Connect PGND to GND, and the low-impedance ground plane of the PCB.	Ground

Pin Description (continued)

PIN		NAME	FUNCTION	TYPE
MAX77654xE NV	MAX77654xE NVN			
LDO				
B6	B6	IN_LDO0	Linear Regulator Input. If connected to a SIMO output with a short trace, IN_LDO0 can share the output's capacitor. Otherwise, bypass with a 2.2 μ F ceramic capacitor to ground. If not used, connect to ground or leave unconnected.	Power Input
A6	A6	IN_LDO1	Linear Regulator Input. If connected to a SIMO output with a short trace, IN_LDO1 can share the output's capacitor. Otherwise, bypass with a 2.2 μ F ceramic capacitor to ground. If not used, connect to ground or leave unconnected.	Power Input
B5	B5	LDO0	Linear Regulator Output 0. Bypass with a 1.0 μ F ceramic capacitor to GND. If not used, disable LDO0 and connect this pin to ground or leave unconnected.	Power Output
A5	A5	LDO1	Linear Regulator Output 1. Bypass with a 1.0 μ F ceramic capacitor to GND. If not used, disable LDO1 and connect this pin to ground or leave unconnected.	Power Output

Detailed Description

The MAX77654 provides a highly-integrated battery charging and power management solution for low-power applications. The linear charger can charge various Li+ batteries with a wide range of charge current and charger termination voltage options. Temperature monitoring and JEITA compliance settings add additional functionality and safety to the charger.

Five regulators are integrated within this device (see [Table 1](#)). A single-inductor, multiple output (SIMO) buck-boost regulator efficiently provides three independently programmable power rails. Two 100mA low-dropout linear regulators (LDOs) provide ripple rejection for audio and other noise sensitive applications.

This device includes other features such as an analog multiplexer that switches several internal voltage and current signals to an external node for monitoring with an external ADC. A bidirectional I²C serial interface allows for configuring and checking the status of the device. An internal on/off controller provides regulator sequencing and supervisory functionality for the device.

Table 1. Regulator Summary

REGULATOR NAME	REGULATOR TOPOLOGY	MAXIMUM I _{OUT} (mA)	V _{IN} RANGE	MAX77654 V _{OUT} RANGE/ RESOLUTION
SBB0	SIMO	Up to 500*	2.7 to 5.5V	0.8 to 5.5V in 50mV steps
SBB1	SIMO	Up to 500*	2.7 to 5.5V	0.8 to 5.5V in 50mV steps
SBB2	SIMO	Up to 500*	2.7 to 5.5V	0.8 to 5.5V in 50mV steps
LDO0/1	PMOS LDOs	100	1.7 to 5.5V	0.8 to 3.975V in 25mV steps

*Shared capacity with other SBBx channels. See the [SIMO Available Output Current](#) section for more information.

Part Number Decoding

The MAX77654 has different one-time programmable (OTP) options and variants to support a variety of applications. OTP options set default settings such as output voltage or CHGIN current limit. Variants are versions of MAX77654 with different features. See [Figure 1](#) for how to identify these. [Table 2](#) and [Table 3](#) list all available OTP options and variants. Refer to [Maxim Integrated naming convention](#) for more details.

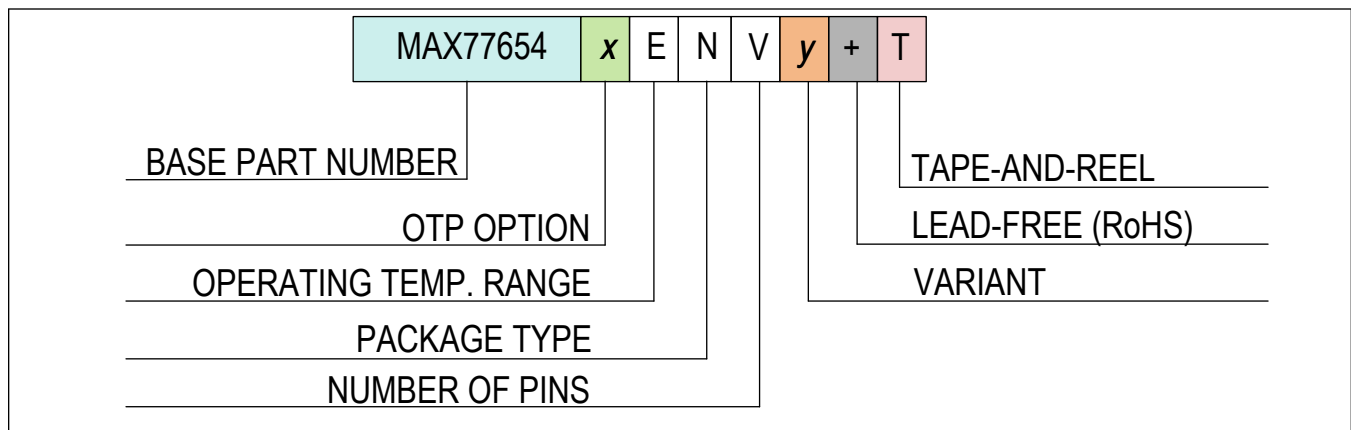

Figure 1. Part Number Decode

Table 2. Variants Table

VARIANT LETTER	NONE	N
Supports Charger, Analog Multiplexer, and Thermistor?	Yes	
Supports SIMO Buck-Boost Regulator?	Yes	Yes
Supports LDO/LSW?	Yes	Yes
Supports I ² C Serial Communication?	Yes	Yes

Table 3. OTP Options Table

		OTP LETTER AND SETTINGS							
VARIANT		NONE							N
Block	Bit Field Name	A	B	C*	D	F	M	N	A
Global	SBIA_LPM (Bias Power Mode)	NPM	NPM	NPM	NPM	NPM	NPM	LPM	NPM
	DBEN_nEN (nEN Debounce time)	500μs	500μs	30ms	500μs	30ms	500μs	500us	500μs
	nEN_MODE	Push-Button	Push-Button	Push-Button	Push-Button	Push-Button	Push-Button	Push-Button	Slide-Switch
	T_MRST (Manual Reset Time)	8s	8s	8s	8s	16s	8s	8s	8s
	ALT_GPIO0 (GPIO0 Mode)	GPIO	Alt.	GPIO	GPIO	GPIO	GPIO	GPIO	GPIO
	ALT_GPIO1 (GPIO1 Mode)	GPIO	Alt.	GPIO	GPIO	GPIO	Alt.	GPIO	GPIO
	ALT_GPIO2 (GPIO2 Mode)	GPIO	Alt.	GPIO	GPIO	GPIO	Alt.	GPIO	GPIO
	ADDR (I ² C Address (7-bit))	0x48	0x48	0x48	0x48	0x48	0x48	0x48	0x48
	UVLO_F[3:0] (SYSUVLO Falling)	2.60V	2.60V	2.85V	2.60V	2.60V	2.60V	2.60V	2.60V
	UVLO_H[3:0] (SYSUVLO Hysteresis)	0.30V	0.30V	0.30V	0.30V	0.15V	0.30V	0.30V	0.30V
	DIDM (Metal Option ID)	0b0	0b0	0b0	0b0	0b0	0b0	0b0	0b0
	CID[4:0] (Chip ID)	0x6	0x2	0x9	0xC	0x12	0xA	0x11	0x7
Watchdog	WDT_LOCK (Watchdog Timer Disable Lock)	Unlocked	Unlocked	Unlocked	Unlocked	Unlocked	Unlocked	Unlocked	Unlocked
	WDT_EN (Watchdog Timer Enable)	Disabled	Disabled	Disabled	Disabled	Disabled	Disabled	Disabled	Disabled
SIMO	TV_SBB0[6:0] (SBB0 V _{OUT})	1.800V	3.000V	4.000V	2.050V	0.800V	1.800V	2.050V	1.350V
	IP_SBB0[1:0] (SBB0 Inductor Current Peak Limit)	0.500A	1.000A	0.500A	0.500A	0.333A	0.500A	0.500A	1.000A
	OP_MODE (SBB0) (SBB0 Operating Mode)	Buck	Buck	Buck-Boost	Buck	Buck	Buck	Buck	Buck

Table 3. OTP Options Table (continued)

		OTP LETTER AND SETTINGS								
Block	VARIANT Bit Field Name	NONE							N	
		A	B	C*	D	F	M	N	A	
	ADE_SBB0 (Active-Discharge Resistor Enable)	Enabled	Enabled	Enabled	Enabled	Disabled	Enabled	Enabled	Enabled	Disabled
	EN_SBB0[2:0] (SBB0 Enable Control)	Off	Off	Off	FPS Slot 0	Off	On	FPS Slot 0	Off	
	TV_SBB1[6:0] (SBB1 V _{OUT})	1.800V	1.800V	1.800V	1.200V	1.850V	1.100V	3.300V	1.800V	
	IP_SBB1[1:0] (SBB1 Inductor Current Peak Limit)	0.500A	1.000A	0.333A	0.500A	0.333A	0.500A	0.500A	1.000A	
	OP_MODE (SBB1) (SBB1 Operating Mode)	Buck	Buck	Buck	Buck	Buck	Buck	Buck-Boost	Buck	
	ADE_SBB1 (Active-Discharge Resistor Enable)	Enabled	Enabled	Enabled	Enabled	Disabled	Enabled	Enabled	Enabled	Disabled
	EN_SBB1[2:0] (SBB1 Enable Control)	FPS Slot 0	On	FPS Slot 0	FPS Slot 3	On	On	FPS Slot 0	FPS Slot 0	
	TV_SBB2[6:0] (SBB2 V _{OUT})	3.500V	3.500V	4.000V	3.300V	0.800V	3.300V	3.300V	3.300V	
	IP_SBB2[1:0] (SBB2 Inductor Current Peak Limit)	0.333A	1.000A	0.333A	0.500A	0.333A	1.000A	0.500A	1.000A	
	OP_MODE (SBB2) (SBB2 Operating Mode)	Buck-Boost	Buck-Boost	Buck-Boost	Buck-Boost	Buck	Buck-Boost	Buck-Boost	Buck-Boost	
	ADE_SBB2 (Active-Discharge Resistor Enable)	Enabled	Enabled	Disabled	Enabled	Disabled	Enabled	Enabled	Enabled	Enabled
	EN_SBB2[2:0] (SBB2 Enable Control)	Off	Off	Off	FPS Slot 0	Off	On	FPS Slot 0	FPS Slot 3	
LDO	TV_LDO0[6:0] (LDO0 V _{OUT})	1.800V	1.800V	1.800V	1.850V	0.800V	1.600V	1.850V	1.200V	
	LDO0_MD (LDO or LSW Mode)	LDO	LDO	LDO	LDO	LDO	LDO	LDO	LDO	
	ADE_LDO0 (Active-Discharge Resistor Enable)	Enabled	Enabled	Enabled	Enabled	Disabled	Enabled	Enabled	Enabled	
	EN_LDO0[2:0] (LDO0 Enable Control)	FPS Slot 0	Off	Off	FPS Slot 1	Off	FPS Slot 3	FPS Slot 1	FPS Slot 1	
	TV_LDO1[6:0] (LDO1 V _{OUT})	3.000V	Don't Care	3.000V	Don't Care	0.800V	Don't Care	1.850V	1.350V	
	LDO1_MD (LDO or LSW Mode)	LDO	LSW	LDO	LSW	LDO	LSW	LDO	LDO	
	ADE_LDO1 (Active-Discharge Resistor Enable)	Enabled	Enabled	Enabled	Disabled	Disabled	Enabled	Enabled	Disabled	
	EN_LDO1[2:0] (LDO1 Enable Control)	Off	Off	Off	Off	Off	FPS Slot 2	FPS Slot 1	Off	

Table 3. OTP Options Table (continued)

		OTP LETTER AND SETTINGS							
VARIANT		NONE							N
Block	Bit Field Name	A	B	C*	D	F	M	N	A
Charger	CHG_EN (Charger Enable)	Enabled	Enabled	Enabled	Disabled	Enabled	Enabled	Enabled	
	ICHGIN_LIM_DEF (Default Charger Input Current Limit)	95mA	95mA	95mA	475mA	475mA	475mA	95mA	

*Future OTP option. Contact Maxim Integrated for availability.

Support Material

The following support materials are available for this device:

- MAX77654 [Register Map](#): Full table of registers that can be read from or written to by I²C.
- MAX77654 [Programmer's Guide](#): Basic software implementation guidance.
- MAX77654 [SIMO Calculator](#): Tool to estimate supported maximum current and ripple for specified conditions.

Top-Level Interconnect Simplified Diagram

[Figure 2](#) shows the same major blocks as the [Typical Applications Circuit](#) with an increased emphasis on the routing between each block. This diagram is intended to familiarize the user with the landscape of the device. Many of the details associated with these signals are discussed throughout the data sheet. At this stage of the data sheet, note the addition of the main bias and clock block that are not shown in the [Typical Applications Circuit](#) section. The main bias and clock block provides voltage, current, and clock references for other blocks as well as many resources for the top-level digital control.

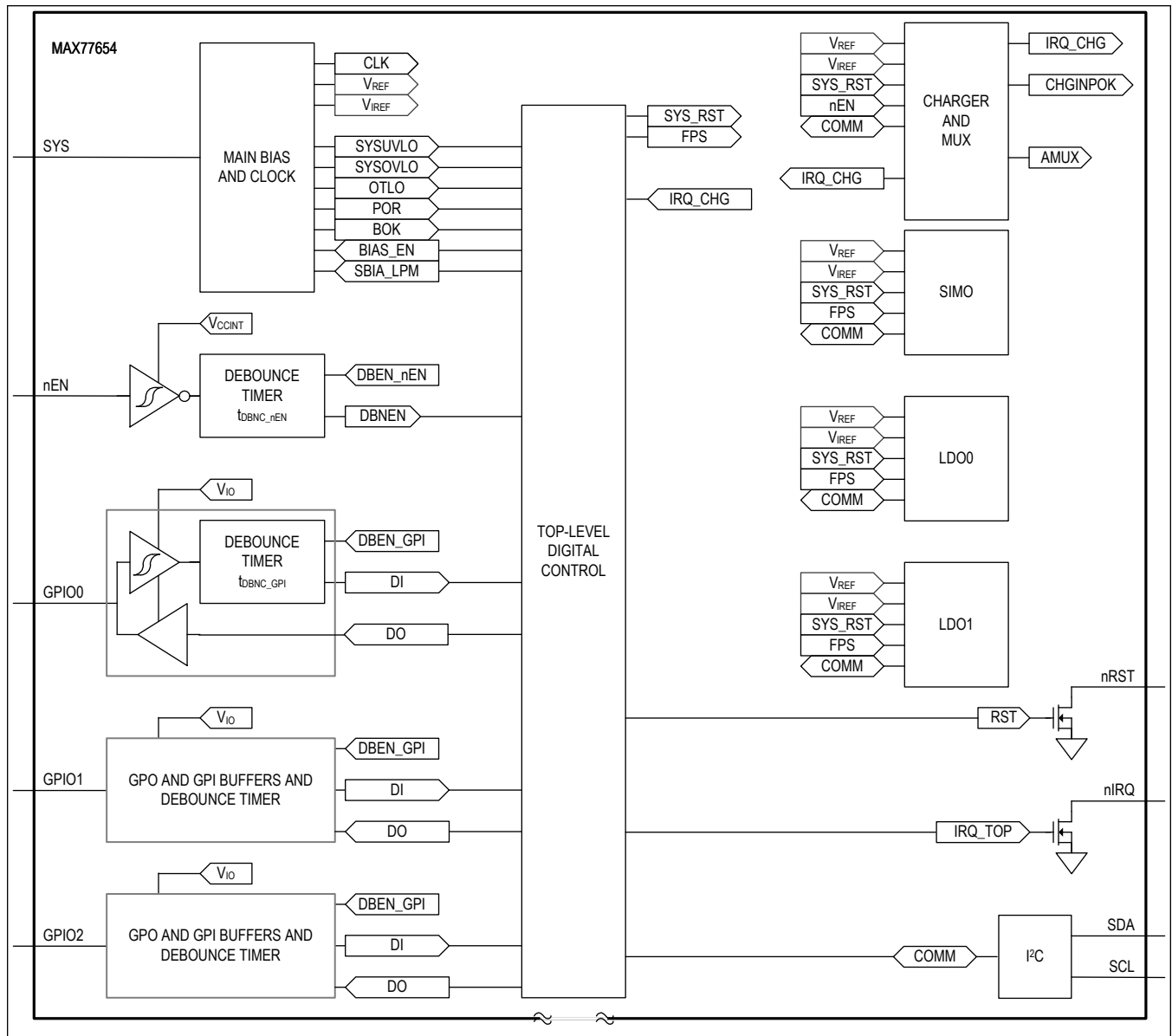

Figure 2. Top-Level Interconnect Simplified Diagram

Detailed Description—Global Resources

The global resources encompass a set of circuits that serve the entire device and ensure safe, consistent, and reliable operation.

Features and Benefits

- Voltage Monitors
 - SYS POR (power-on-reset) comparator generates a reset signal upon power-up.
 - SYS undervoltage ensures repeatable behavior when power is applied to and removed from the device.
 - SYS overvoltage monitor inhibits operation with overvoltage power sources to ensure reliability in faulty environments.
- Thermal Monitors
 - +165°C junction temperature shutdown
- Manual Reset
 - 8s or 16s period
- Wake-up Events
 - Charger insertion (with 120ms debounce)
 - nEN input assertion
- Interrupt Handler
 - Interrupt output (nIRQ)
 - All interrupts are maskable
- Push-Button/Slide-Switch On-key (nEN)
 - Configurable push-button/slide-switch functionality
 - 500 μ s or 30ms debounce timer interfaces directly with mechanical switches
- On/Off Controller
 - Startup/shut-down sequencing
 - Programmable sequencing delay
- GPIO, RST Digital I/Os

Voltage Monitors

The device monitors the system voltage (V_{SYS}) to ensure proper operation using three comparators (POR, UVLO, and OVLO). These comparators include hysteresis to prevent their outputs from toggling between states during noisy system transitions.

SYS POR Comparator

The SYS POR comparator monitors V_{SYS} and generates a power-on reset signal (POR). When V_{SYS} is below V_{POR} , the device is held in reset (SYSRST = 1). When V_{SYS} rises above V_{POR} , internal signals and on-chip memory stabilize and the device is released from reset (SYSRST = 0).

SYS Undervoltage-Lockout Comparator

The SYS undervoltage-lockout (UVLO) comparator monitors V_{SYS} and generates a SYSUVLO signal when the V_{SYS} falls below UVLO threshold. The SYSUVLO signal is provided to the top-level digital controller. See [Figure 6](#) and [Table 6](#) for additional information regarding the UVLO comparator:

- When the device is in the STANDBY state, the UVLO comparator is disabled.
- When transitioning out of the STANDBY state, the UVLO comparator is enabled allowing the device to check for sufficient input voltage. If the device has sufficient input voltage, it can transition to the RESOURCE ON state; if there is insufficient input voltage, the device transitions back to the STANDBY state.

SYS Overvoltage-Lockout Comparator

The device is rated for 5.5V maximum operating voltage (V_{SYS}) with an absolute maximum input voltage of 6.0V. An overvoltage-lockout monitor increases the robustness of the device by inhibiting operation when the supply voltage is greater than $V_{SYSOVLO}$. See [Figure 6](#) and [Table 6](#) for additional information regarding the OVLO comparator:

- When the device is in the STANDBY state, the OVLO comparator is disabled.

Chip Identification

The MAX77654 offers different one-time-programmable (OTP) options to, for example, set the default output voltages. These options are identified by the chip identification number, which can be read in the CID register.

nEN Enable Input

nEN is an active-low internally debounced digital input that typically comes from the system's on-key. The debounce time is programmable with $CNFG_GLBL.DBEN_nEN$. The primary purpose of this input is to generate a wake-up signal for the PMIC that turns on the regulators. Maskable rising/falling interrupts are available for nEN ($INT_GLBL0.nEN_R$ and $INT_GLBL0.nEN_F$) for alternate functionality.

The nEN input can be configured to work either with a push-button ($CNFG_GLBL.nEN_MODE = 0$) or a slide-switch ($CNFG_GLBL.nEN_MODE = 1$). See [Figure 3](#) for more information. In both push-button mode and slide-switch mode, the on/off controller looks for a falling edge on the nEN input to initiate a power-up sequence.

nEN Manual Reset

nEN works as a manual reset input when the on/off controller is in the "Resource-On" state. The manual reset function is useful for forcing a power-down in case communication with the processor fails. When nEN is configured for push-button mode and the input is asserted (nEN = LOW) for an extended period (t_{MRST}), the on/off controller initiates a power-down sequence and goes to standby mode. When nEN is configured for slide-switch mode and the input is deasserted (nEN = HIGH) for an extended period (t_{MRST}), the on/off controller initiates a power-down sequence and goes to standby mode.

nEN Dual-Functionality: Push-Button vs. Slide-Switch

The nEN digital input can be configured to work with a push-button or a slide-switch. The timing diagram below shows nENs dual functionality for power-on sequencing and manual reset. The default configuration of the device is push-button mode ($CNFG_GLBL.nEN_MODE = 0$) and no additional programming is necessary. Applications that use a slide-switch on-key configuration must set $CNFG_GLBL.nEN_MODE = 1$ within t_{MRST} .

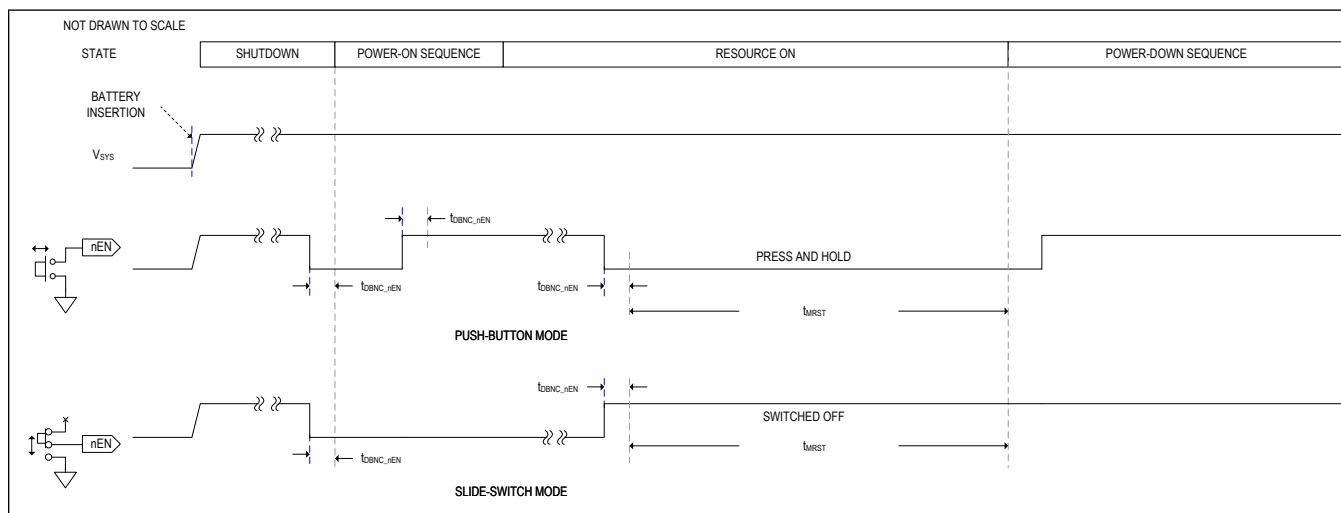

Figure 3. nEN Usage Timing Diagram

nEN Internal Pullup Resistors to V_{CCINT}

The nEN logic thresholds are referenced to V_{CCINT}, an always-on internal voltage domain. There are internal pullup resistors between nEN and V_{CCINT} (R_{nEN_PU}), which can be configured with the CNFG_GLBL_A.PU_DIS bit. See [Figure 4](#). While PU_DIS = 0, the pullup value is approximately 200kΩ. While PU_DIS = 1, the pullup value is 10MΩ.

V_{CCINT} defined by the following conditions:

- V_{CCINT} = V_L (3V typ.) if CHGIN is valid (STAT_CHG_B.CHGIN_DTLS[1:0] = 0b11) and not USB suspended (CNFG_CHG_G.USBS = 0).
- V_{CCINT} = V_{BATT} if CHGIN is invalid (STAT_CHG_B.CHGIN_DTLS[1:0] ≠ 0b11) or CHGIN is valid but USB suspended (CNFG_CHG_G.USBS = 1).

Applications using a slide-switch on-key or push-pull digital output connected to nEN can reduce quiescent current consumption by changing pullup strength to 10MΩ. Applications using normally-open, momentary, and push-button on-keys (as shown in [Figure 4](#)) do not create this leakage path and should use the stronger 200kΩ pullup option.

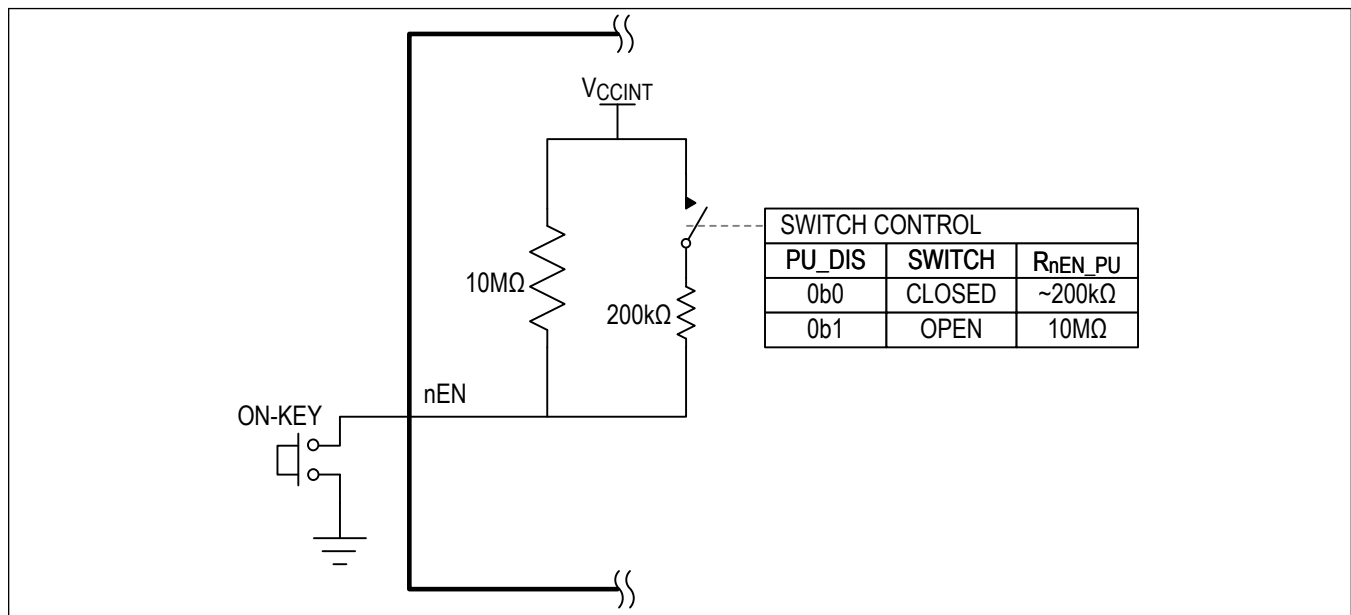

Figure 4. nEN Pullup Resistor Configuration

Interrupts (nIRQ)

nIRQ is an active-low, open-drain output that is typically routed to the host processor's interrupt input to signal an important change in device status. See the [Register Map](#) section for a comprehensive list of all interrupt bits and status registers.

A pullup resistor to a voltage less than or equal to V_{SYS} is required for this node. nIRQ is the logical NOR of all unmasked interrupt bits in the register map.

All interrupts are masked by default. Masked interrupt bits do not cause the nIRQ pin to change. Unmask the interrupt bits to allow nIRQ to assert.

Reset Output (nRST)

nRST is an open-drain, active-low output that is typically used to hold the processor in a reset state when the device is powered down. During a power-up sequence, the nRST deasserts after the last regulator in the power-up chain is enabled (t_{RSTODD}). During a power-down sequence, the nRST output asserts before any regulator is powered down (t_{RSTOAD}). See [Figure 10](#) for nRST timing.

A pullup resistor to a voltage less than or equal to V_{SYS} is required for this node.

General-Purpose Input Output (GPIO)

The provided general-purpose input/output (GPIO) pins increase system flexibility. See [Figure 5](#) for more details.

Clear CNFG_GPIOx.DIR to configure GPIO as a general-purpose output (GPO). The GPO can either be in push-pull mode (CNFG_GPIOx.DRV = 1) or open-drain mode (CNFG_GPIOx.DRV = 0).

- The push-pull output mode is ideal for applications that need fast (~2ns) edges and low power consumption.
- The open-drain mode requires an external pullup resistor (typically 10k Ω –100k Ω). Connect the external pullup resistor to a bias voltage that is less than or equal to V_{IO} .
 - The open-drain mode can be used to communicate to different logic domains. For example, to send a signal from the GPO on a 1.8V logic domain ($V_{IO} = 1.8V$) to a device on a 1.2V logic domain, connect the external pullup resistor to 1.2V.
 - The open-drain mode can be used to connect several open-drain (or open-collector) devices together on the same bus to create wired logic (wired AND logic is positive-true; wired OR logic is negative-true).
- The general-purpose input (GPI) functions are still available while the pin is configured as a GPO. In other words, the CNFG_GPIOx.DI (input status) bit still functions and does not collide with the state of the CNFG_GPIOx.DIR bit.

Set CNFG_GPIOx.DIR to have the GPIO function as a GPI. The GPI features a 30ms debounce timer (t_{DBNC_GPI}) that can be enabled or disabled with DBEN_GPI.

- Enable the debounce timer (CNFG_GPIOx.DBEN_GPI = 1) if the GPI is connected to a device that can bounce or chatter, like a mechanical switch.
- If the GPI is connected to a circuit with clean logic transitions and no risk of bounce, disable the debounce timer (CNFG_GPIOx.DBEN_GPI = 0) to eliminate logic delays. With no debounce timer, the GPI input logic propagates to nIRQ in 10ns.

A dedicated internal oscillator is used to create the 30ms (t_{DBNC_GPI}) debounce timer. To obtain low V_{IO} supply current, ensure the GPIO voltage is either logic high or logic low. If the GPIO pin is unconnected (either as a GPI or an open-drain GPO) and V_{IO} is powered, the GPIO voltage trends towards the logic level gray area ($0.3 \times V_{IO} < V_{GPIO} < 0.7 \times V_{IO}$). If V_{GPIO} is in the gray area, V_{IO} current can be more than 10 μ A.

The GPI features edge detectors that feed into the the top-level interrupt system of the chip. This allows software to use interrupts to service events associated with a GPI change instead of polling for these changes.

- If the application wants nIRQ to go low **only on a GPI rising edge**, then it should **clear** the GPI rising edge interrupt mask bit (INTM_GLBL1.GPI_RM = 0) and **set** the GPI falling edge interrupt mask bit (INTM_GLBL1.GPI_FM = 1).
- If the application wants nIRQ to go low **only on a GPI falling edge**, then it should **set** the GPI rising edge interrupt mask bit (INTM_GLBL1.GPI_RM = 1) and **clear** the GPI falling edge interrupt mask bit (INTM_GLBL1.GPI_FM = 0).
- If the application wants nIRQ to go low **on both GPI falling and rising edges**, then it should **clear** the GPI rising edge interrupt mask bit (INTM_GLBL1.GPI_RM = 0) and **clear** the GPI falling edge interrupt mask bit (INTM_GLBL1.GPI_FM = 0).

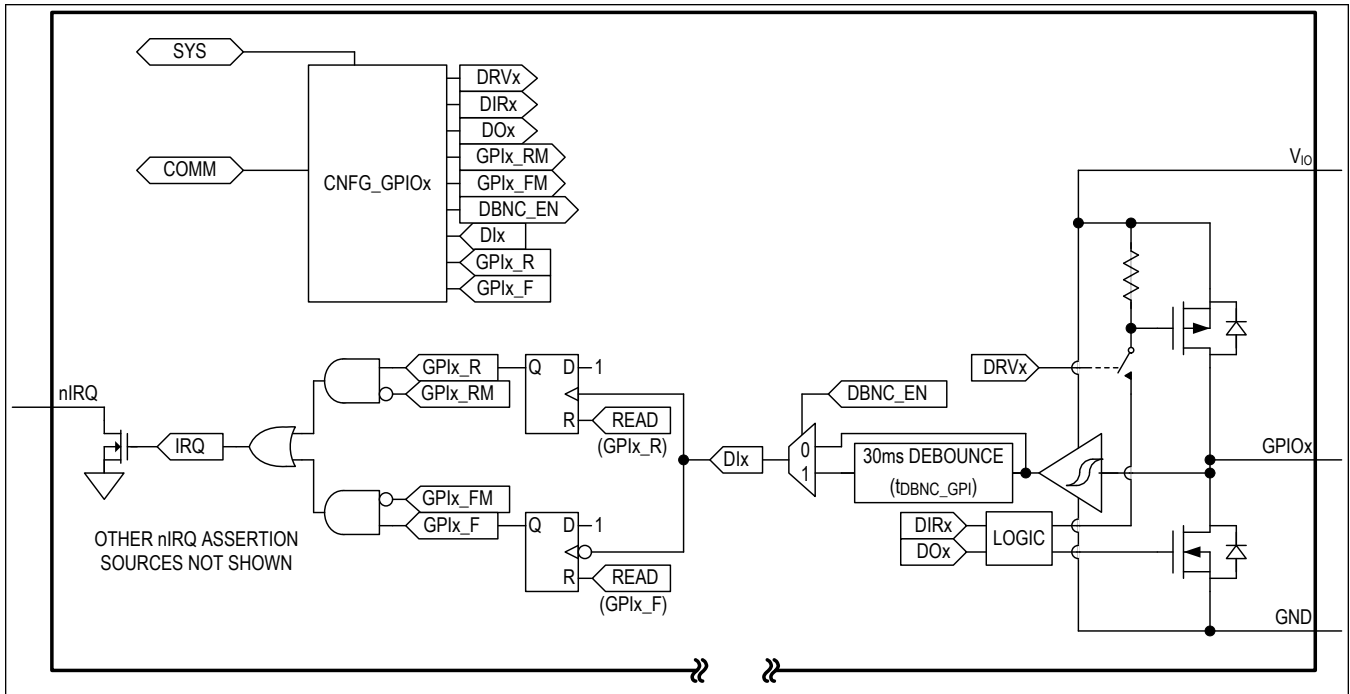

Figure 5. GPIOx Block Diagram

Alternate Mode

Each GPIO in the MAX77654 can be configured to have a different function. Whether a particular GPIO is in GPIO mode or alternate mode can be checked by reading the CNFG_GPIOx.ALT_GPIOx bit. Table 4 summarizes the alternate functions for each GPIO.

Table 4. GPIO Mode

GPIOx	CNFG_GPIOx REGISTER	
	ALT_GPIOx = 0	ALT_GPIOx = 1
GPIO0	Standard GPIO	Active-high output of SBB2s flexible power sequencer (FPS) slot.
GPIO1	Standard GPIO	Active-high input, enable control for SBB2. SBB2 also still powers up and down according to the FPS.
GPIO2	Standard GPIO	Active-high input, enable control for low-power mode.

In particular, for GPIO1s alternate mode, SBB2 is enabled if GPIO1 = 1 OR the FPS enables SBB2. See the [Flexible Power Sequencer](#) section for more details. Table 5 summarizes how to enable or disable SBB2 if GPIO1 is configured to be in its alternate mode.

The value of GPIO2 is OR'd with CNFG_GLBL.SBIA_LPM, so setting SBIA_LPM = 1 or setting GPIO2 HIGH requests bias lower-power mode.

Table 5. Enabling/Disabling SBB2 while GPIO1 is in Alternate Mode

GPIO1	CNFG_SBB2.EN_SBB2[2:0]	
	0b000 - 0b011, 0b110, 0b111	0b100 to 0b101
GPIO1 = 0	SBB2 Enabled	SBB2 Disabled
GPIO1 = 1	SBB2 Enabled	SBB2 Enabled

On/Off Controller

The on/off controller monitors multiple power-up (wake-up) and power-down (shutdown) conditions to enable or disable resources that are necessary for the system and its processor to move between its operating modes.

Many systems have one power management controller and one processor and rely on the on/off controller to be the master controller. In this case, the on/off controller receives wake-up events and enables some or all of the regulators to power-up a processor. That processor then manages the system. To conceptualize this master operation, see [Figure 6](#) and [Table 6](#). A typical path through the on/off controller is:

1. Apply a battery and start in the shutdown state.
2. Press the system's on-key (nEN = LOW) and follow transitions 4 and 6 to the resource-on state. If any resources are on the FPS, transitions 7A and 7B are followed.
3. The device performs its desired functions in the resource-on state. when it is ready to turn off, a manual reset first drives the transition through transitions 8A and 8B to the standby state. Afterward, the device automatically follows transition 3 to the shutdown state.

Some systems have several power management blocks, a main processor, and subprocessors. These systems can use this device as a subpower management block for a peripheral portion of circuitry as long as there is an I²C port available from a higher level processor. To conceptualize this operation, see [Figure 6](#) and [Table 6](#). A typical path through the on/off controller used in this way is:

1. Apply a battery to the system and start in the shutdown state.
2. When the higher level processor wants to turn on this device's resources, it enables the main bias circuits through I²C (CNFG_GLBL.SBIA_EN = 1) to transition along path 6 to the resource-on state.
3. The higher level processor can now control this device's resources with I²C commands, e.g., turn on/off regulators.
4. When the higher level processor is ready to turn this device off, it turns off everything through I²C and then disables the main bias circuits through I²C (CNFG_GLBL.SBIA_EN = 0) to transition along path 5B to the standby state.

Note that in this style of operation, the CNFG_GLBL_SFT_CTRL[1:0] bits should not be used to turn the device off. The CNFG_GLBL_SFT_CTRL[1:0] bits establish directives to the on/off controller itself that does not make sense in this subpower management block operation. If the processor uses I²C commands to enable the device's resources, the processor should also use I²C commands to disable them.

Top Level On/Off Controller

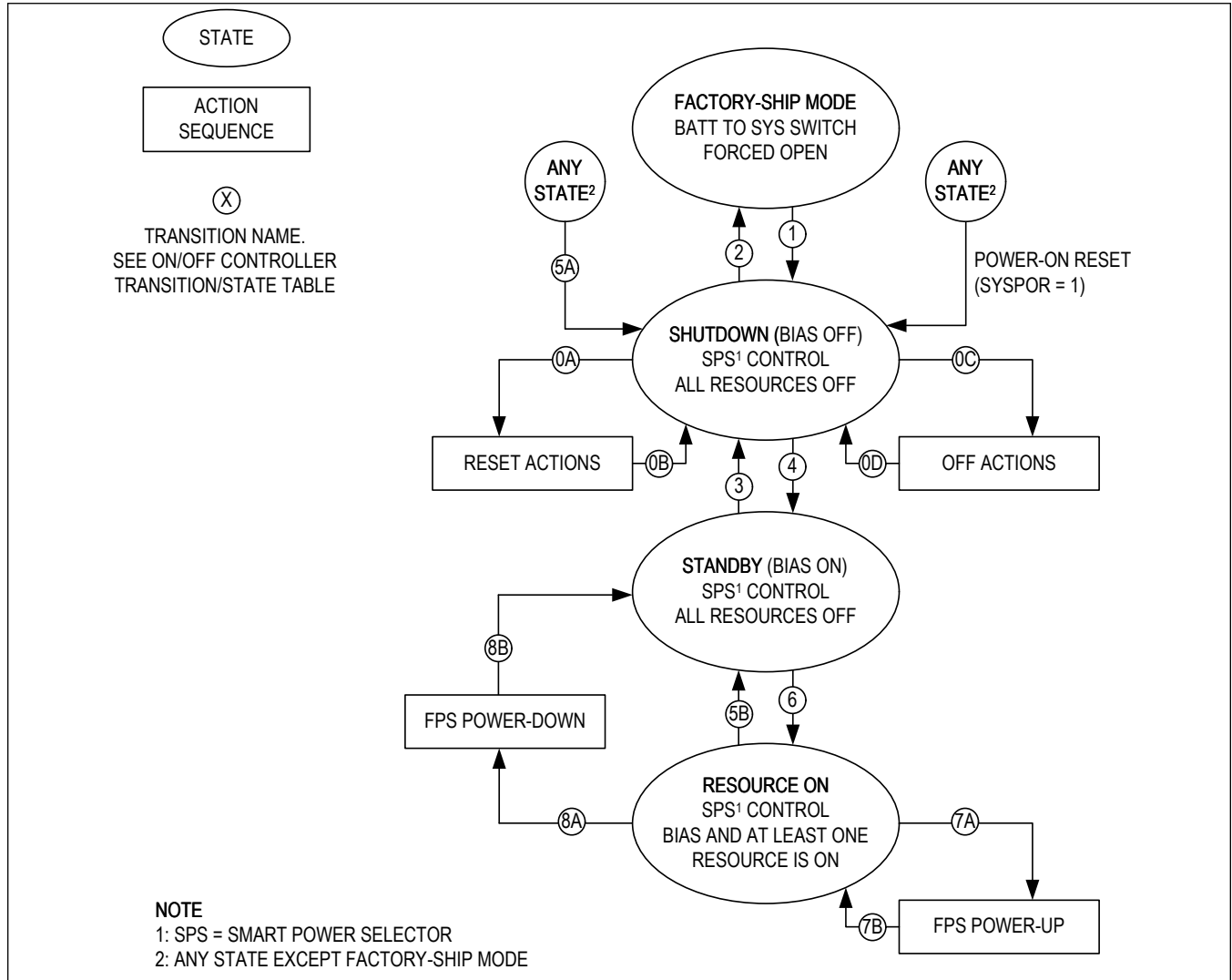

Figure 6. Top Level On/Off Controller State Diagram

On/Off Controller Transition Table

Table 6. On/Off Controller Transition/State

TRANSITION	CONDITION (TRANSITION HAPPENS WHEN...)
0A	Software cold reset (CNFG_GLBL.SFT_CTRL[1:0] = 0b01) OR Watchdog timer expired and caused reset (ERCFLAG.WDT_RST = 1, CNFG_WDT.WDT_MODE = 1)
0B	Reset actions completed
0C	Software power-off (CNFG_GLBL.SFT_CTRL[1:0] = 0b10) OR Watchdog expired and caused power-off (ERCFLAG.WDT_OFF = 1, CNFG_WDT.WDT_MODE = 0) OR Chip over-temperature lockout (T _J > T _{OTLO}) OR SYS undervoltage lockout (V _{SYS} < V _{SYSUVLO} + V _{SYSUVLO_HYS}) OR SYS overvoltage lockout (V _{SYS} > V _{SYSOVLO}) OR Manual reset occurred (ERCFLAG.MRST = 1)

Table 6. On/Off Controller Transition/State (continued)

TRANSITION	CONDITION (TRANSITION HAPPENS WHEN...)
0D	Off actions completed
1	CHGIN inserted and 120ms debounce valid (STAT_CHG_B.CHGIN_DTLS[1:0] = 0b11) OR nEN asserted and debounced (t _{FSM-DB}) OR Power to the IC is removed (V _{BATT} < approx. 1.6V) and then reapplied (V _{BATT} > V _{POR})
2	Factory-ship mode requested (CNFG_GLBL.SFT_CTRL[1:0] = 0b11) AND nEN not asserted
3	NOT (Transition 4) Factory-ship mode requested (CNFG_GLBL.SFT_CTRL[1:0] = 0b11) OR Software cold reset (CNFG_GLBL.SFT_CTRL[1:0] = 0b01) OR Software power-off (CNFG_GLBL.SFT_CTRL[1:0] = 0b10) OR Watchdog timer expired OR Manual reset occurred (ERCFLAG.MRT = 1)
4	Main bias requested enabled through I ² C (CNFG_GLBL.SBIA_EN = 1) OR Transition 6
5A	Chip over-temperature lockout (T _J > T _{OTLO}) OR SYS undervoltage lockout (V _{SYS} < V _{SYSUVLO} + V _{SYSUVLO_HYS}) OR SYS overvoltage lockout (V _{SYS} > V _{SYSOVLO})
5B	NOT (Transition 6) OR Factory-ship mode requested (CNFG_GLBL.SFT_CTRL[1:0] = 0b11) OR Software cold reset (CNFG_GLBL.SFT_CTRL[1:0] = 0b01) OR Software power-off (CNFG_GLBL.SFT_CTRL[1:0] = 0b10) OR Watchdog timer expired OR Manual reset occurred (ERCFLAG.MRT = 1)
6	AMUX is being used (CNFG_CHG_I.MUX_SEL[3:0] ≠ 0b0000) OR CHGIN inserted and debounced (STAT_CHG_B.CHGIN_DTLS[1:0] = 0b11) OR Any resources force enabled OR Internal wake-up flags are set (see the Internal Wake-Up Flags section)
7A	FPS power-up sequence has not happened yet AND Resources are not forced off AND Internal wake-up flags are set (see the Internal Wake-Up Flags section)
7B	FPS power-up sequence done
8A	FPS power-up sequence completed AND All resources are force disabled OR Factory-ship mode requested (CNFG_GLBL.SFT_CTRL[1:0] = 0b11) OR Software cold reset (CNFG_GLBL.SFT_CTRL[1:0] = 0b01) OR Software power-off (CNFG_GLBL.SFT_CTRL[1:0] = 0b10) OR Watchdog timer expired OR Manual reset occurred (ERCFLAG.MRT = 1)
8B	FPS power-down sequence finished

Internal Wake-Up Flags

After transitioning to the shutdown state because of a reset, to allow the device to power-up again, internal wake-up flags are set to remember the wake-up request. In [Figure 6](#) and [Table 6](#), these internal wake-up flags trigger transitions 6 and 7A. The internal wake-up flags are set when any of the following happen:

- nEN is debounced (see the [nEN Enable Input](#) section)
 - For example, after a push-button is pressed or a slide-switch switched to HIGH.
- CHGIN is debounced and valid (STAT_CHG_B.CHGIN_DTLS[1:0] = 0b11)
- Software cold reset command sent (CNFG_GLBL.SFT_CTRL[1:0] = 0b01)

Reset and Off Sequences

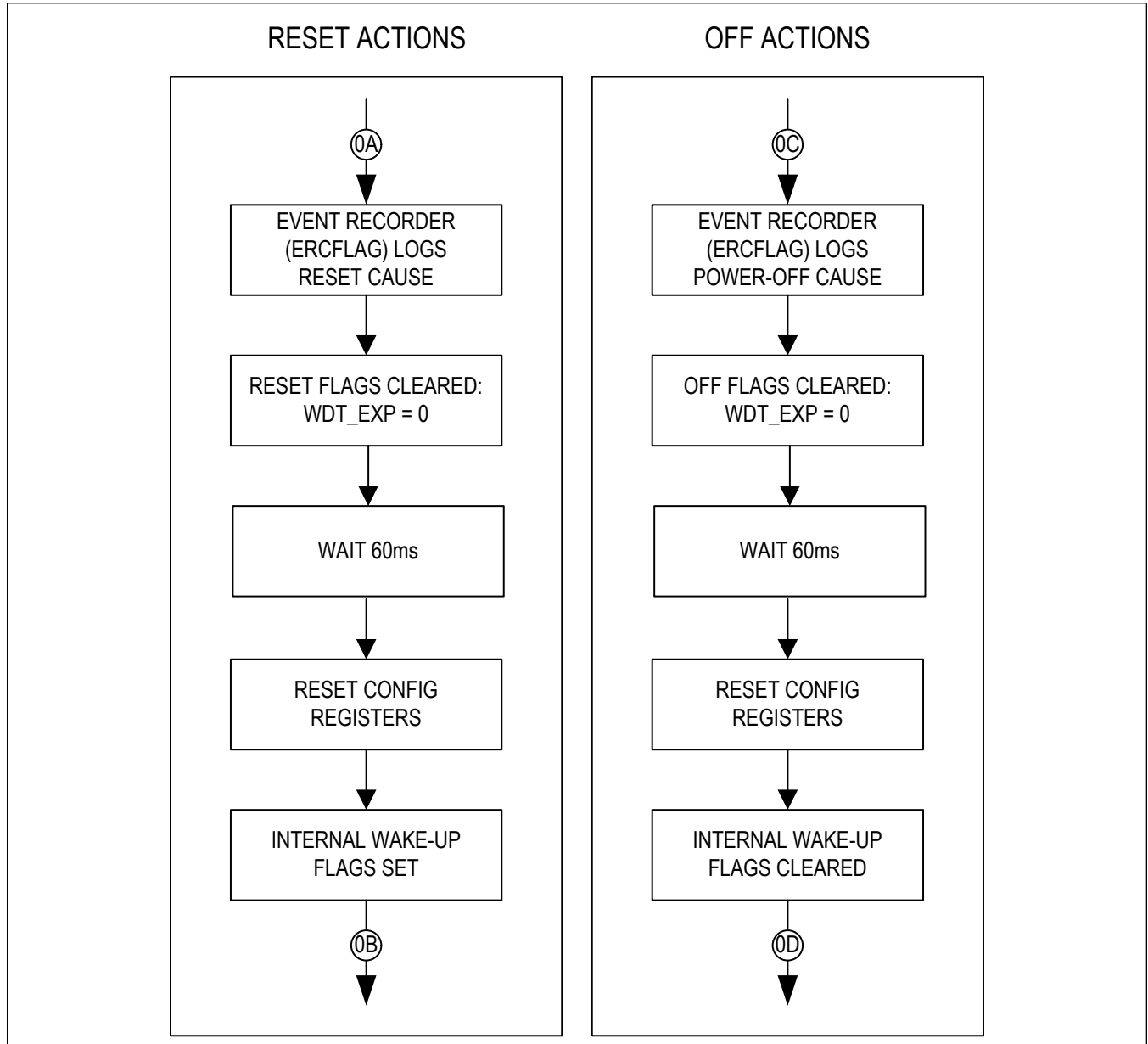

Figure 7. On/Off Controller Reset and Off-Action Sequences

Power-Up/Down Sequence

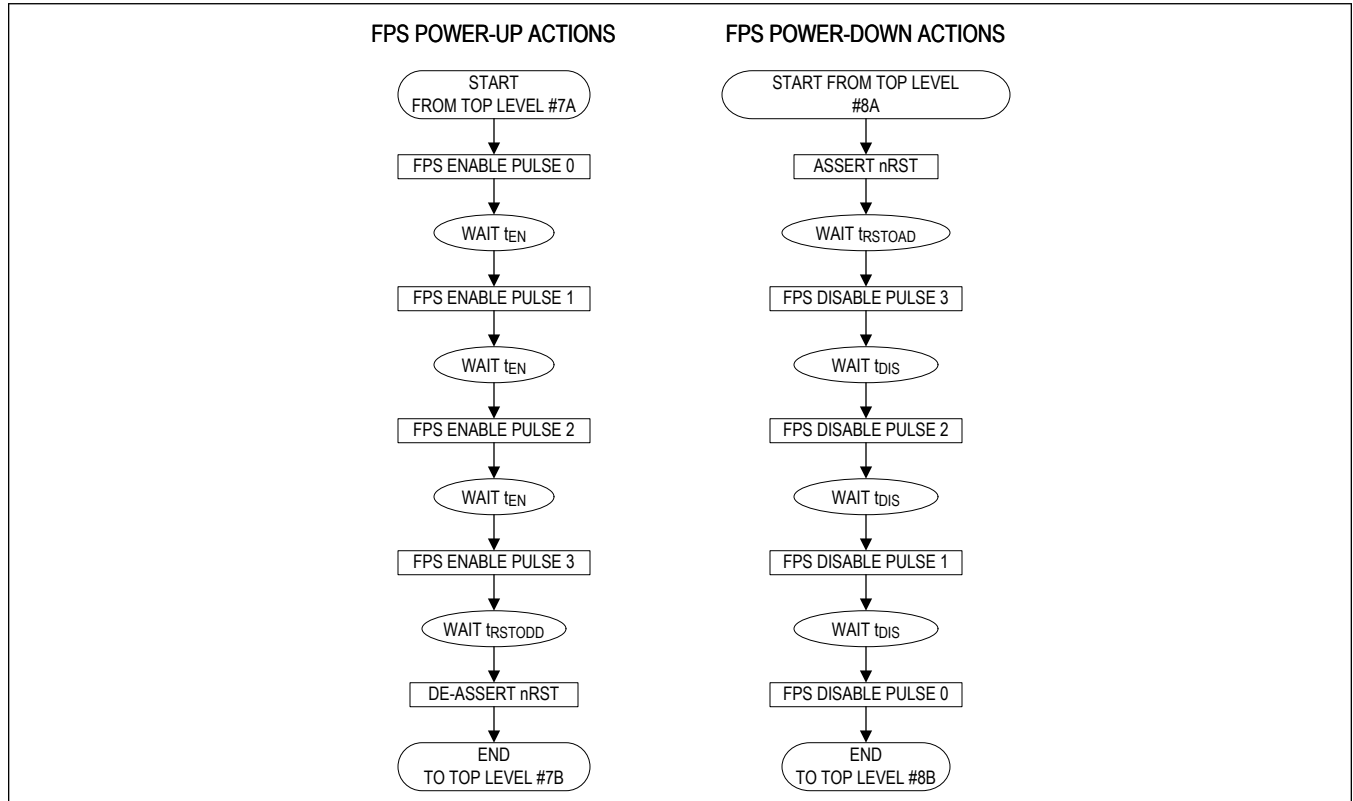

Figure 8. Power-Up/Down Sequence

Flexible Power Sequencer (FPS)

The FPS allows resources to power up under hardware or software control. Additionally, each resource can power up independently or among a group of other regulators with adjustable power-up/down delays (sequencing). [Figure 9](#) shows four resources powering up under the control of the flexible power sequencer.

The flexible sequencing structure consists of one master sequencing timer and four slave resources (SBB0, SBB1, SBB2 and LDO). When the FPS is enabled, a master timer generates four sequencing events for device power-up/down.

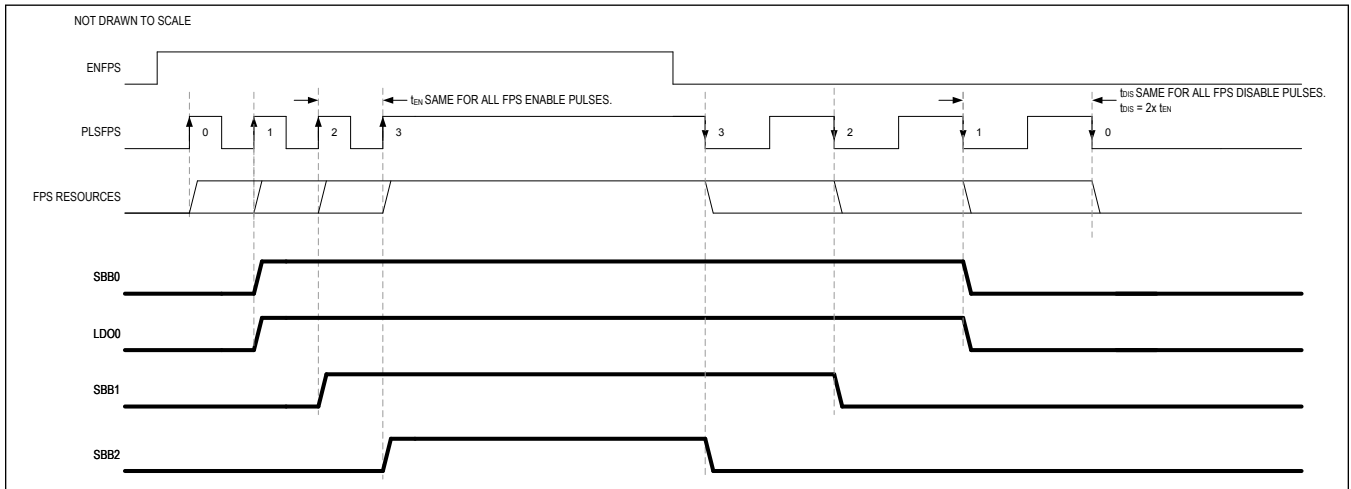

Figure 9. Flexible Power Sequencer Basic Timing Diagram

Startup Timing Diagram Due to nEN

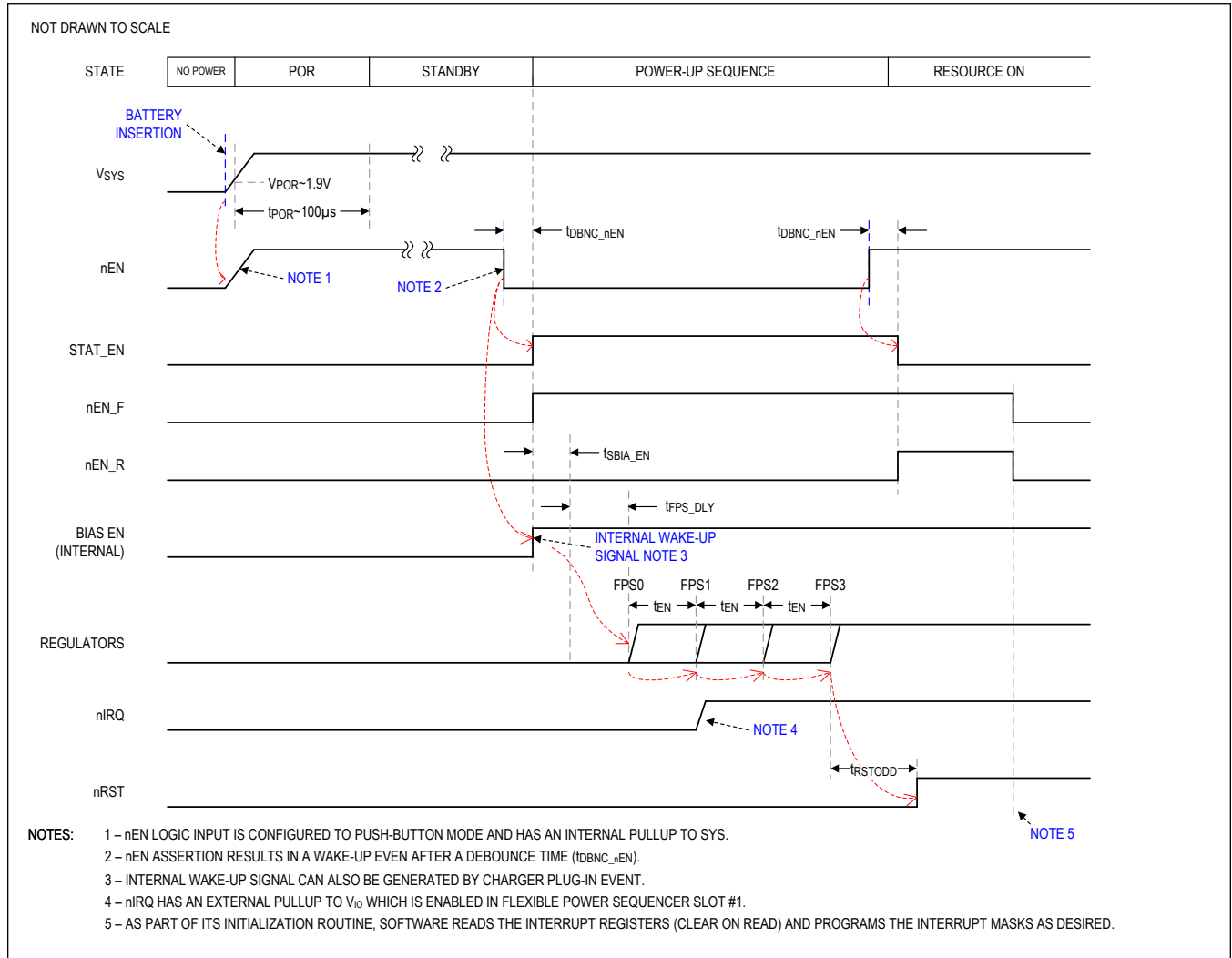

Figure 10. Startup Timing Diagram Due to nEN

Startup Timing Diagram Due to Charge Source Insertion

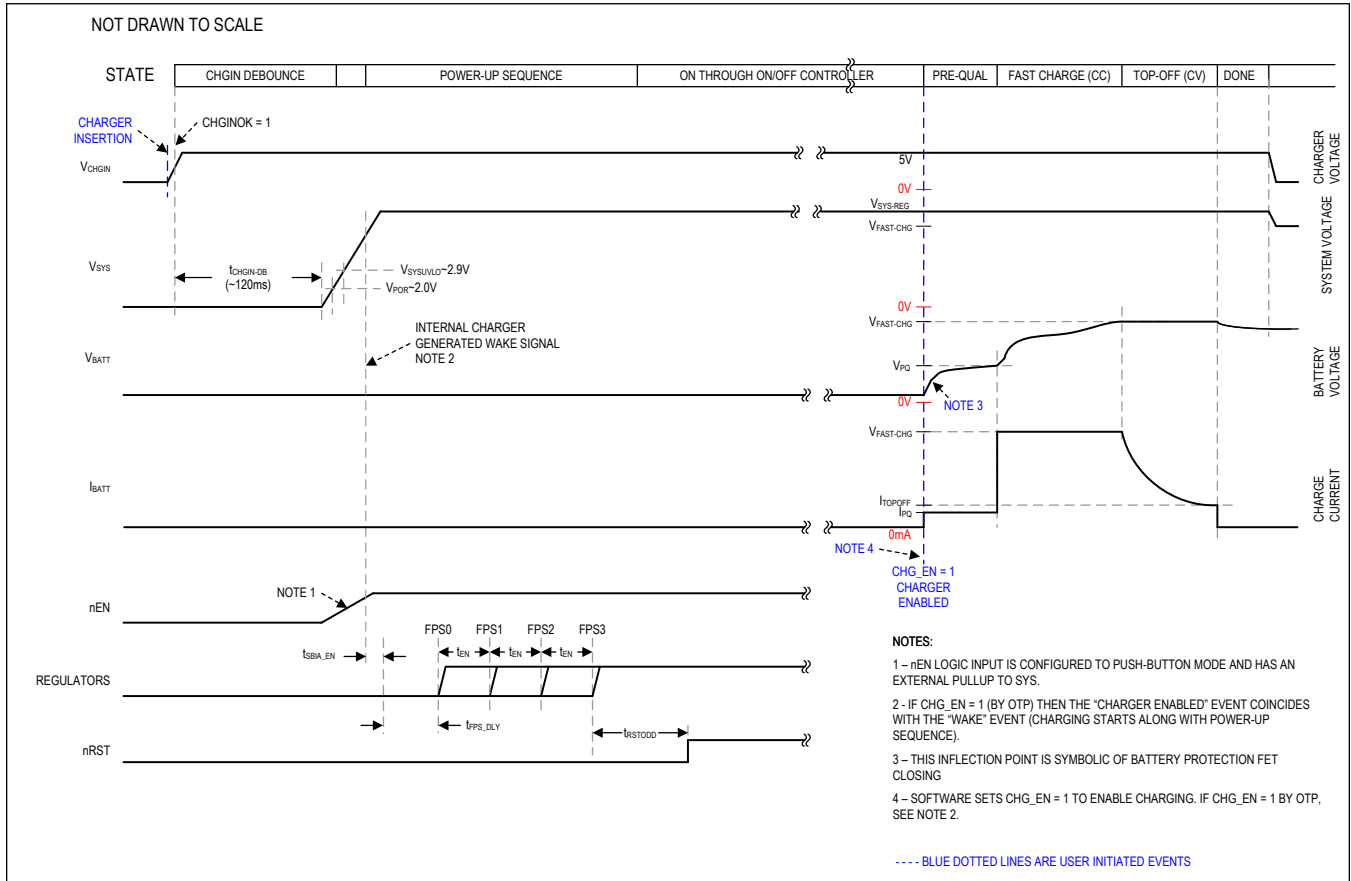

Figure 11. Startup Timing Diagram Due to Charge Source Insertion

Force Enabled/Disabled Channels

Force enable SIMO and LDO output channels by setting CNFG_SBBx_B.EN_SBBx[2:0] (SIMO) or CNFG_LDOx_B.EN_LDOx[2:0] (LDO) = 0x6. Depending on the OTP, output channels may already be force enabled by default. Output channels configured this way are independent of the flexible power sequence and start up as soon as SYS > UVLO rising. The main bias also automatically turns on.

Likewise, output channels can be force disabled by setting EN_SBBx[2:0] or EN_LDOx[2:0] = 0x4.

Factory-Ship Mode State

Factory-ship mode internally disconnects the battery (BATT) from the system (SYS). The battery does not power the system in this mode. Use this mode to preserve battery life if external circuits on SYS cause the battery to leak.

Write `CNFG_GLBL.SFT_CTRL[1:0] = 0b11` using I²C to enter factory-ship mode. The IC responds in two different ways depending on the state of the charger input (CHGIN):

- If CHGIN is valid (`STAT_CHG_B.CHGIN_DTLS[1:0] = 0b11`) while `CNFG_GLBL.SFT_CTRL[1:0] = 0b11`, then the IC enters factory-ship mode (internally disconnects BATT from SYS) but SYS is still powered from CHGIN (regulating to $V_{\text{SYS-REG}}$). SYS decays to 0V when CHGIN is disconnected.
- If CHGIN is invalid (`STAT_CHG_B.CHG_DTLS[1:0] ≠ 0b11`) while `CNFG_GLBL.SFT_CTRL[1:0] = 0b11`, then the IC enters factory-ship mode and SYS decays to 0V.

Factory-ship mode causes many configuration registers to reset (SYSRST). See the [Register Map](#) section for details. I²C reads and writes cannot happen in factory-ship mode.

Factory-ship mode exits only after SYS decays below approximately 1.8V. Once this condition is met, there are two ways to exit factory-ship mode:

- Apply a valid DC source at CHGIN for $t_{\text{CHGIN-DB}}$ (120ms typical). Factory-ship mode is unlatched (exited) when the charger input becomes valid from a previously invalid state (`STAT_CHG_B.CHGIN_DTLS[1:0] = 0b00 → 0b11`).
- Assert `nEN` for $t_{\text{FSM-EXDB}}$ (250ms typical) + $t_{\text{DBNC_nEN}}$.

Furthermore, this state is unlatched if power is removed from the IC (BATT voltage falls below approximately 1.8V). In all exit cases, the smart power selector controls the interaction between BATT and SYS until factory-ship mode is entered again (see the [Smart Power Selector](#) section).

Debounced Inputs (nEN, GPI, CHGIN)

`nEN`, `CHGIN`, and `GPI` (when operating as an input), are debounced on both rising and falling edges to reject undesired transitions. The input must be at a stable logic level for the entire debounce period for the output to change its logic state. [Figure 12](#) shows an example timing diagram for the `nEN` debounce.

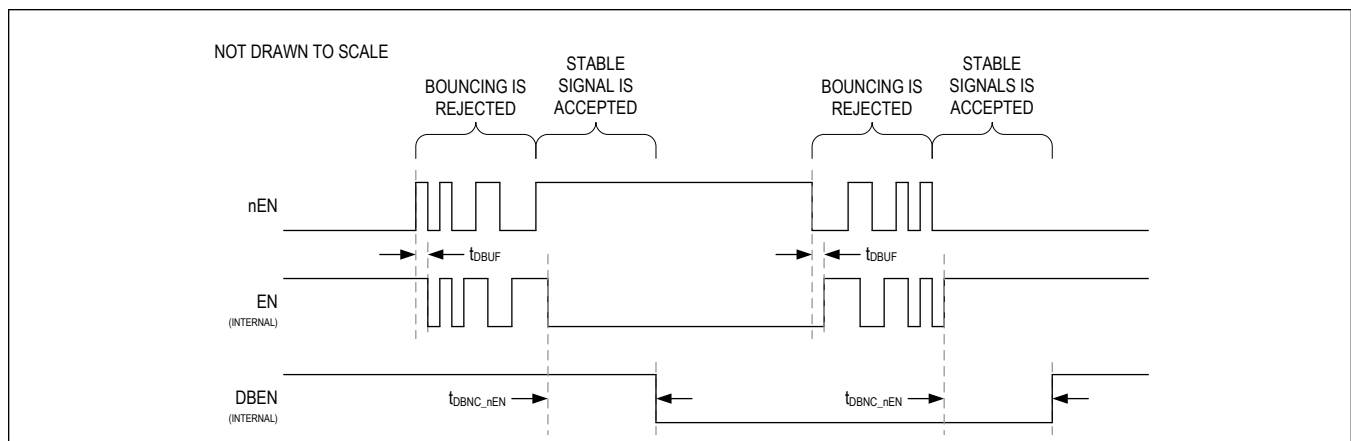

Figure 12. Debounced Inputs

Watchdog Timer (WDT)

The IC features a watchdog timer function for operational safety. If this timer expires without being cleared, the on/off controller causes the IC to enter the shutdown state and resets configuration registers. See the [On/Off Controller](#) and [On/Off Controller Transition Table](#) sections (transitions 0A and 0C) for more details.

Write `CNFG_WDT.WDT_EN = 1` through I²C to enable the timer. The watchdog timer period (t_{WD}) is configurable from 16 to 128 seconds in 4 steps with `CNFG_WDT.WDT_PER[1:0]`. The default timer period is 128 seconds. While the watchdog timer is enabled, the `CNFG_WDT.WDT_CLR` bit must be set through I²C periodically (within t_{WD}) to reset the timer and prevent shutdown. See the [Register Map](#) and [Figure 13](#) for additional details.

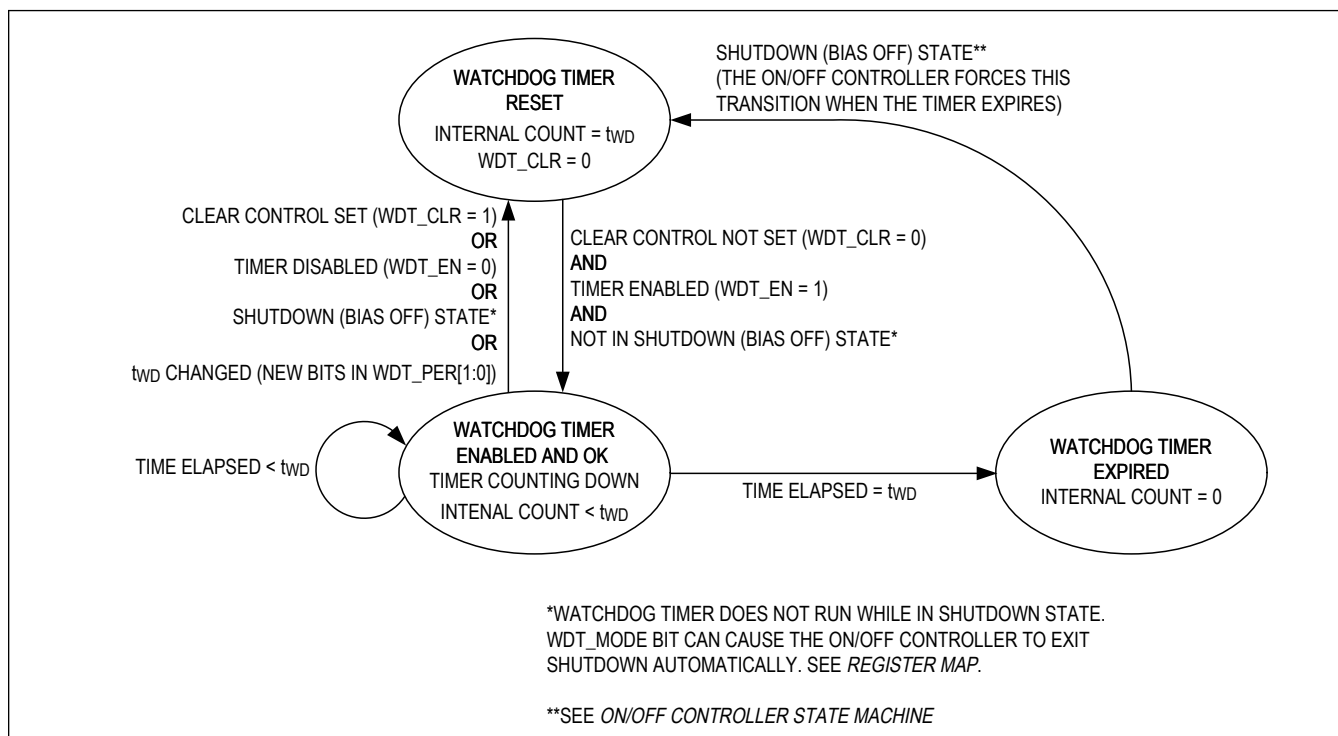

Figure 13. Watchdog Timer State Machine

The timer can be factory-programmed to be enabled by default, disabled by default, or locked from accidental disable. The `CNFG_WDT.WDT_LOCK` bit is read-only and must be configured at the factory. See [Table 7](#) for a full description.

Table 7. Watchdog Timer Factory-Programmed Safety Options

WDT_LOCK	WDT_EN	FUNCTION
0	0	Watchdog timer is disabled by default. Timer can be enabled or disabled by I ² C writes.
0	1	Watchdog timer is enabled by default. Timer can be enabled or disabled by I ² C writes.
1	0	Watchdog timer is disabled by default. Timer can be enabled by an I ² C write, but only a SYSRST can reset the <code>CNFG_WDT.WDT_EN</code> value back to 0. Timer can not be disabled by direct I ² C writes to <code>CNFG_WDT.WDT_EN</code> (write from 1 → 0 is ignored, write from 0 → 1 is accepted).
1	1	Watchdog timer is enabled by default. Nothing can disable the timer.

Detailed Description—Smart Power Selector Charger

The linear Li+ charger implements power path with Maxim's Smart Power Selector. This allows separate input current limit and battery charge current settings. Batteries charge faster under the supervision of the Smart Power Selector because charge current is independently regulated and not shared with variable system loads. See the [Smart Power Selector](#) section for more information.

The programmable constant-current charge rate (7.5mA to 300mA) supports a wide range of battery capacities. The programmable input current limit (95mA to 475mA) supports a range of charge sources, including USB. The charger's programmable battery regulation voltage range (3.6V to 4.6V) supports a wide variety of cell chemistries. Small battery capacities are supported; the charger accurately terminates charging by detecting battery currents as low as 0.375mA.

Additionally, the robust charger input withstands overvoltages up to 28V. To enhance charger safety, an NTC thermistor provides temperature monitoring in accordance with the JEITA recommendations. See the [Adjustable Thermistor Temperature Monitors](#) section for more information.

Charger Symbol Reference Guide

[Table 8](#) lists the names and functions of charger-specific signals and if they can be programmed through I²C serial communication. See the [Electrical Characteristics](#) and [Register Map](#) for more information.

Table 8. Charger Quick Symbol Reference Guide

SYMBOL	NAME	I ² C PROGRAMMABLE?
V _{CHGIN_OVP}	CHGIN overvoltage threshold	No
V _{CHGIN_UVLO}	CHGIN undervoltage-lockout threshold	No
V _{CHGIN-MIN}	Minimum CHGIN voltage regulation setpoint	Yes, through CNFG_CHG_B.VCHGIN_MIN[2:0]
I _{CHGIN-LIM}	CHGIN input current limit	Yes, through CNFG_CHG_B.ICHGIN_LIM[2:0]
V _{SYS-REG}	SYS voltage regulation target	Yes, through CNFG_CHG_D.VSYS_REG[4:0]
V _{SYS-MIN}	Minimum SYS voltage regulation setpoint	No, tracks V _{SYS-REG}
V _{FAST-CHG}	Fast-charge constant-voltage level	Yes, through CNFG_CHG_G.CHG_CV[5:0]
I _{FAST-CHG}	Fast-charge constant-current level	Yes, through CNFG_CHG_G_E.CHG_CC[5:0]
I _{PQ}	Prequalification current level	Yes, through CNFG_CHG_B.I_PQ
V _{PQ}	Prequalification voltage threshold	Yes, through CNFG_CHG_C.CHG_PQ[2:0]
I _{TERM}	Termination current level	Yes, through CNFG_CHG_C.I_TERM[1:0]
T _{J-REG}	Die temperature regulation setpoint	Yes, through CNFG_CHG_D.TJ_REG[2:0]
t _{PQ}	Prequalification safety timer	No
t _{FC}	Fast-charge safety timer	Yes, through CNFG_CHG_E.T_FAST_CHG[1:0]
t _{TO}	Top-off timer	Yes, through CNFG_CHG_C.T_TOPOFF[2:0]

[Figure 14](#) indicates the high-level functions of each control circuit within the linear charger.

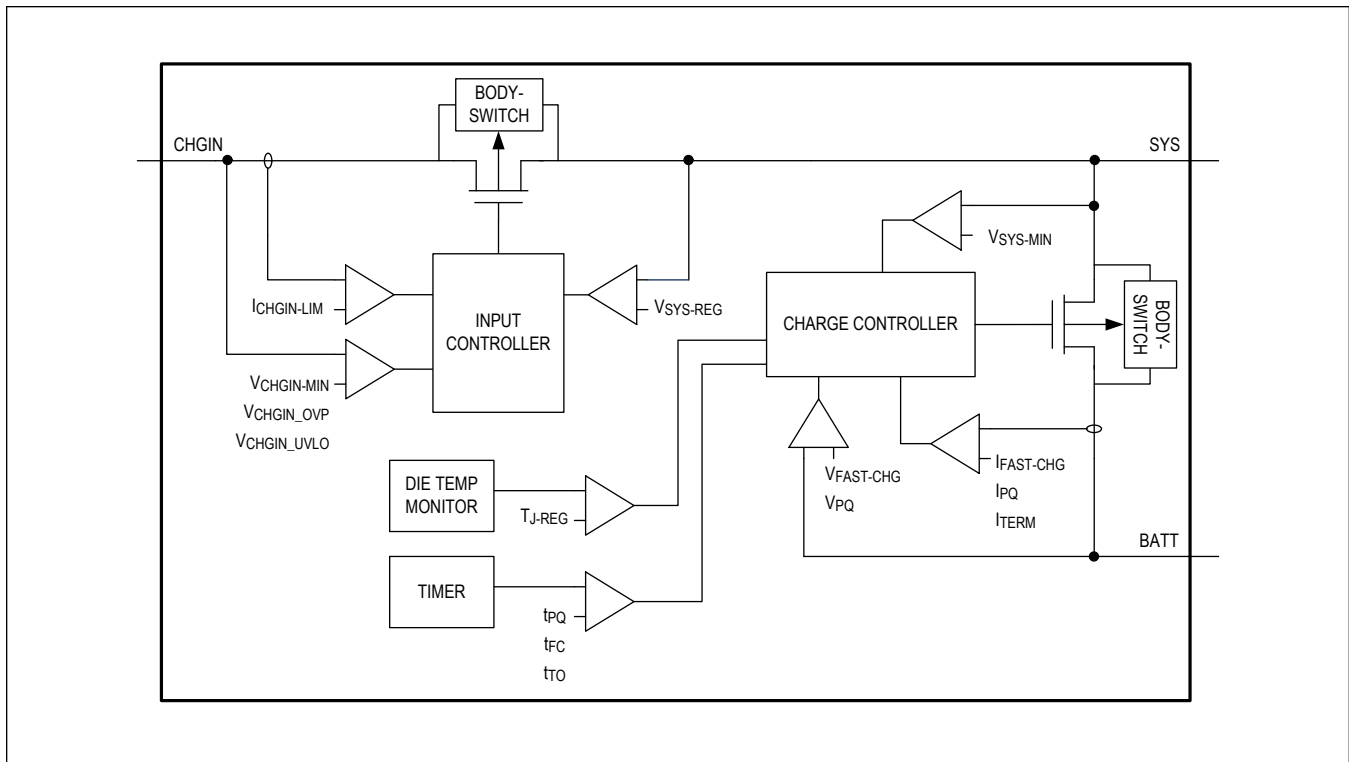

Figure 14. Charger Simplified Control Loops

Smart Power Selector

The Smart Power Selector seamlessly distributes power from the input (CHGIN) to the battery (BATT) and the system (SYS). The Smart Power Selector basic functions are:

- When the system load current is less than the input current limit, the battery is charged with residual power from the input.
- When a valid input source is connected, the system regulates to $V_{SYS-REG}$ to power system loads regardless of the battery's voltage (instant on).
- When the system load current exceeds the input current limit, the battery provides additional current to the system (supplement mode).
- When the battery is finished charging and an input source is present to power the system, the battery remains disconnected from the system.
- When the battery is connected and there is no input power, the system is powered from the battery.

Input Current Limiter

The input current limiter limits CHGIN current to not exceed $I_{CHGIN-LIM}$ (programmed by `CNFG_CHG_B.ICHGIN_LIM[2:0]`). A maskable interrupt (`INT_CHG.CHGIN_CTRL_I`) signals when the input current limit engages. The `STAT_CHG_A.ICHGIN_LIM_STAT` bit reflects the state of the current limiter loop.

The default value of $I_{CHGIN-LIM}$ is factory-programmable to either 95mA or 475mA. The decoding of the `CNFG_CHG_B.ICHGIN_LIM[2:0]` bitfield changes depending on the factory-programmed default value (see [Table 9](#)). The reset value of this bitfield is always 0b000 regardless of factory option.

Table 9. Input Current Limit Factory Options

ICHGIN_LIM[2:0]	95mA Factory-Default	475mA Factory-Default
0b000	95mA	475mA
0b001	190mA	380mA
0b010	285mA	285mA
0b011	380mA	190mA
0b100 to 0b111	475mA	95mA

CHGIN is capable of withstanding a maximum of 28V with respect to ground. CHGIN suspends power delivery to the system and battery when V_{CHGIN} exceeds V_{CHGIN_OVP} (7.5V, typ). The input circuit also suspends when V_{CHGIN} falls below V_{CHGIN_UVLO} minus 500mV of hysteresis (3.5V, typ). While in OVP or UVLO, the charger remains off and the battery provides power to the system.

Power transfer to SYS is delayed by a 120ms debounce timer ($t_{CHGIN-DB}$) after a valid DC source is connected to CHGIN. SYS does not begin regulating to $V_{SYS-REG}$ until after the timer expires.

The STAT_CHG_B.CHGIN_DTLS[1:0] bitfield continuously indicates the state of CHGINs voltage quality. A maskable interrupt (INT_CHG.CHGIN_I) asserts when STAT_CHG_B.CHGIN_DTLS[1:0] changes.

Minimum Input Voltage Regulation

In the event of a poor-quality charge source, the minimum input voltage regulation loop works to reduce input current if V_{CHGIN} falls below $V_{CHGIN-MIN}$ (programmed by CNFG_CHG_B.VCHGIN_MIN[2:0]). This is important because many commonly used charge adapters feature foldback protection mechanisms where the adapter completely shuts off if its output drops too low. The minimum input voltage regulation loop also prevents V_{CHGIN} from dropping below V_{CHGIN_UVLO} if the cable between the charge source and the charger's input is long or highly resistive.

The input voltage regulation loop improves performance with current limited adapters. If the charger's input current limit is programmed above the current limit of the given adapter, the input voltage loop allows the input to regulate at the current limit of the adapter. The input voltage regulation loop also allows the charger to perform well with adapters that have poor transient load response times.

A maskable interrupt (INT_CHG.CHGIN_CTRL_I) signals when the minimum input voltage regulation loop engages. The state of this loop is reflected by STAT_CHG_A.VCHGIN_MIN_STAT.

Minimum System Voltage Regulation

The minimum system voltage regulation loop ensures that the system rail remains close to the programmed SYS regulation voltage ($V_{\text{SYS-REG}}$) regardless of system loading. The loop engages when the combined battery charge current and system load current causes the CHGIN input to current limit at $I_{\text{CHGIN-LIM}}$. When this happens, the minimum system voltage loop reduces charge current in an attempt to keep the input out of current limit, thereby keeping the system voltage above $V_{\text{SYS-MIN}}$ ($V_{\text{SYS-REG}} - 100\text{mV}$, typ). If this loop reduces battery current to 0 and the system is in need of more current than the input can provide, then the Smart Power Selector overrides the minimum system voltage regulation loop and allows SYS to collapse to BATT for the battery to provide supplement current to the system. The Smart Power Selector automatically reenables the minimum system voltage loop when the supplement event has ended.

A maskable interrupt (INT_CHG.SYS_CTRL_I) asserts to signal a change in STAT_CHG_A.VSYS_MIN_STAT. This status bit asserts when the minimum system voltage regulation loop is active.

Die Temperature Regulation

If the die temperature exceeds $T_{\text{J-REG}}$ (programmed by CNFG_CHG_D.TJ_REG[2:0]) the charger attempts to limit the temperature increase by reducing the battery charge current. The STAT_CHG_A.TJ_REG_STAT bit asserts whenever charge current is reduced due to this loop. The charger's current sourcing capability to SYS remains unaffected when STAT_CHG_A.TJ_REG_STAT is high. A maskable interrupt (INT_CHG.TJ_REG_I) asserts to signal a change in STAT_CHG_A.TJ_REG_STAT. Use the INT_CHG.TJ_REG_I interrupt to signal the system processor to reduce loads on SYS to reduce total system temperature.

Charger State Machine

The battery charger follows a strict state-to-state progression to ensure that a battery is charged safely. The status bitfield STAT_CHG_B.CHG_DTLS[3:0] reflects the charger's current operational state. A maskable interrupt (INT_CHG.CHG_I) is available to signal a change in STAT_CHG_B.CHG_DTLS[3:0].

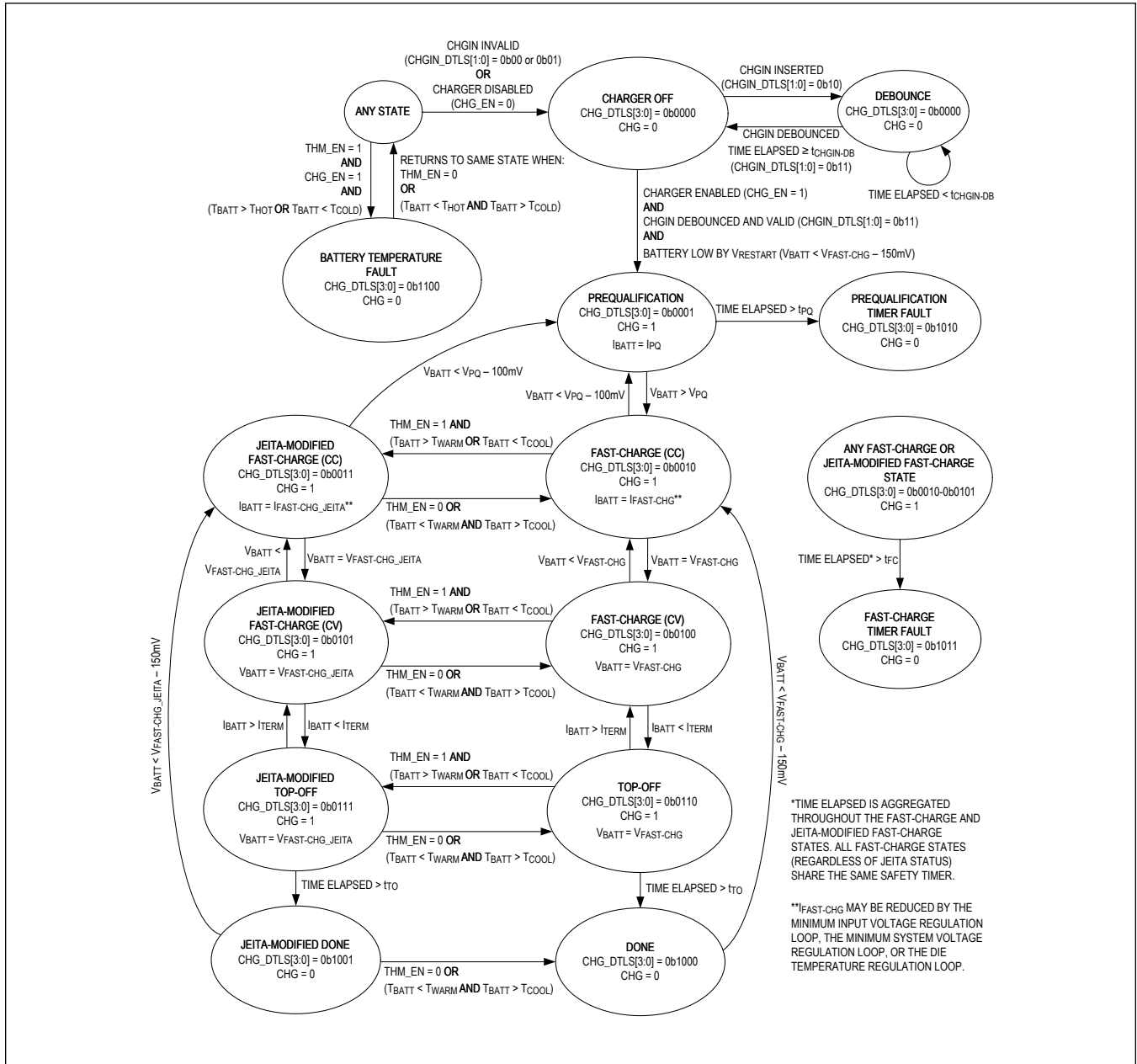

Figure 15. Charger State Diagram

Charger-Off State

The charger is off when CHGIN is invalid, the charger is disabled, or the battery is fresh.

CHGIN is invalid when the CHGIN input is invalid ($V_{CHGIN} < V_{CHGIN_UVLO}$ or $V_{CHGIN} > V_{CHGIN_OVP}$). While CHGIN is invalid, the battery is connected to the system. CHGIN voltage quality can be separately monitored by the STAT_CHG_B.CHGIN_DTLS[1:0] status bitfield. See the [Register Map](#) section for details.

The charger is disabled when the charger enable bit is 0 (CNFG_CHG_B.CHG_EN = 0). The battery is connected or disconnected to the system depending on the validity of V_{CHGIN} while CNFG_CHG_B.CHG_EN = 0. See the [Smart Power Selector](#) section.

The battery is fresh when CHGIN is valid and the charger is enabled (CNFG_CHG_B.B.CHG_EN = 1) and the battery is not low by $V_{RESTART}$ ($V_{BATT} > V_{FAST-CHG} - V_{RESTART}$). The battery is disconnected from the system and not charged while the battery is fresh. The charger state machine exits this state and begins charging when the battery becomes low by $V_{RESTART}$ (150mV, typ). This condition is functionally similar to done state. See the [Done State](#) section.

Prequalification State

The prequalification state is intended to assess a low-voltage battery's health by charging at a reduced rate. If the battery voltage is less than the V_{PQ} threshold, the charger is automatically in prequalification. If the cell voltage does not exceed V_{PQ} in 30 minutes (t_{PQ}), the charger faults. The prequalification charge rate is a percentage of $I_{FAST-CHG}$ and is programmable with CNFG_CHG_B.I_PQ. The prequalification voltage threshold (V_{PQ}) is programmable through CNFG_CHG_C.CHG_PQ[2:0].

Fast-Charge States

When the battery voltage is above V_{PQ} , the charger transitions to the fast-charge (CC) state. In this state, the charger delivers a constant current ($I_{FAST-CHG}$) to the cell. The constant current level is programmable from 7.5mA to 300mA by CNFG_CHG_E.CHG_CC[5:0].

When the cell voltage reaches $V_{FAST-CHG}$, the charger state machine transitions to fast-charge (CV). $V_{FAST-CHG}$ is programmable with CNFG_CHG_G.CHG_CV[5:0] from 3.6V to 4.6V. The charger holds the battery's voltage constant at $V_{FAST-CHG}$ while in the fast-charge (CV) state. As the battery approaches full, the current accepted by the battery reduces. When the charger detects that battery charge current has fallen below I_{TERM} , the charger state machine enters the top-off state.

A fast-charge safety timer starts when the state machine enters fast-charge (CC) or JEITA-modified fast-charge (CC) from a non-fast-charge state. The timer continues to run through all fast-charge states regardless of JEITA status. The timer length (t_{FC}) is programmable from 3 hours to 7 hours in 2 hour increments with CNFG_CHG_E.T_FAST_CHG[1:0]. If it is desired to charge without a safety timer, program CNFG_CHG_E.T_FAST_CHG[1:0] with 0b00 to disable the feature. If the timer expires before the fast-charge states are exited, the charger faults. See the [Fast-Charge Timer Fault State](#) section for more information.

If the charge current falls below 20% of the programmed value during fast-charge (CC), the safety timer pauses. The timer also pauses for the duration of supplement mode events. The STAT_CHG_B.TIME_SUS bit indicates the status of the fast-charge safety timer. See the [Register Map](#) section for more details.

Top-Off State

Top-off state is entered when the battery charge current falls below I_{TERM} during the fast-charge (CV) state. I_{TERM} is a percentage of $I_{FAST-CHG}$ and is programmable through CNFG_CHG_C.I_TERM[1:0]. While in the top-off state, the battery charger continues to hold the battery's voltage at $V_{FAST-CHG}$. A programmable top-off timer starts when the charger state machine enters the top-off state. When the timer expires, the charger enters the done state. The top-off timer value (t_{TO}) is programmable from 0 minutes to 35 minutes with CNFG_CHG_C.T_TOPOFF[2:0]. If it is desired to stop charging as soon as battery current falls below I_{TERM} , program t_{TO} to 0 minutes.

Done State

The charger enters the done state when the top-off timer expires. The battery remains disconnected from the system during done. The charger restarts if the battery voltage falls more than V_{RESTART} (150mV, typ) below the programmed $V_{\text{FAST-CHG}}$ value.

Prequalification Timer Fault State

The prequalification timer fault state is entered when the battery's voltage fails to rise above V_{PQ} in t_{TO} (30 minutes, typ) from when the prequalification state was first entered. If a battery is too deeply discharged, damaged, or internally shorted, the prequalification timer fault state can occur. During the timer fault state, the charger stops delivering current to the battery and the battery remains disconnected from the system. To exit the prequalification timer fault state, toggle the charger enable (CNFG_CHG_B.CHG_EN) bit or unplug and replug the external voltage source connected to CHGIN.

Fast-Charge Timer Fault State

The charger enters the fast-charge timer fault state if the fast-charge safety timer expires. While in this state, the charger stops delivering current to the battery and the battery remains disconnected from the system. To exit the fast-charge timer fault state, toggle the charger enable bit (CNFG_CHG_B.CHG_EN) or unplug and replug the external voltage source connected to CHGIN.

Battery Temperature Fault State

If the thermistor monitoring circuit reports that the battery is either too hot or too cold to charge (as programmed by CNFG_CHG_A.THM_HOT[1:0] and CNFG_CHG_A.THM_COLD[1:0]), the state machine enters the battery temperature fault state. While in this state, the charger stops delivering current to the battery and the battery remains disconnected from the system. This state can only be entered if the thermistor is enabled (CNFG_CHG_F.THM_EN = 1). Battery temperature fault state has priority over any other fault state, and can be exited when the thermistor is disabled (CNFG_CHG_F.THM_EN = 0) or when the battery returns to an acceptable temperature. When this fault state is exited, the state machine returns to the last state it was in before battery temperature fault state was entered.

All active charger timers (fast-charge safety timer, prequalification timer, or top-off timer) are paused in this state. When the charger exits this state, the prequalification timer resumes while the fast-charge safety and top-off timers reset.

The STAT_CHG_A.THM_DTLS[2:0] bitfield reports battery temperature status. See the [Adjustable Thermistor Temperature Monitors](#) and the [Register Map](#) sections for more information.

JEITA-Modified States

If the thermistor is enabled (CNFG_CHG_F.THM_EN = 1), then the charger state machine is allowed to enter the JEITA-modified states. These states are entered if the charger's temperature monitors indicate that the battery temperature is either warm (greater than T_{WARM}) or cool (lesser than T_{COOL}). See the [Adjustable Thermistor Temperature Monitors](#) section for more information about setting the temperature thresholds.

The charger's current and voltage parameters change from $I_{\text{FAST-CHG}}$ and $V_{\text{FAST-CHG}}$ to $I_{\text{FAST-CHG_JEITA}}$ and $V_{\text{FAST-CHG_JEITA}}$ while in the JEITA-modified states. The JEITA modified parameters can be independently set to lower voltage and current values so that the battery can charge safely over a wide range of ambient temperatures. If the battery temperature returns to normal, or the thermistor is disabled (CNFG_CHG_.THM_EN = 0), the charger exits the JEITA-modified states.

Typical Charge Profile

A typical battery charge profile (and state progression) is illustrated in [Figure 16](#).

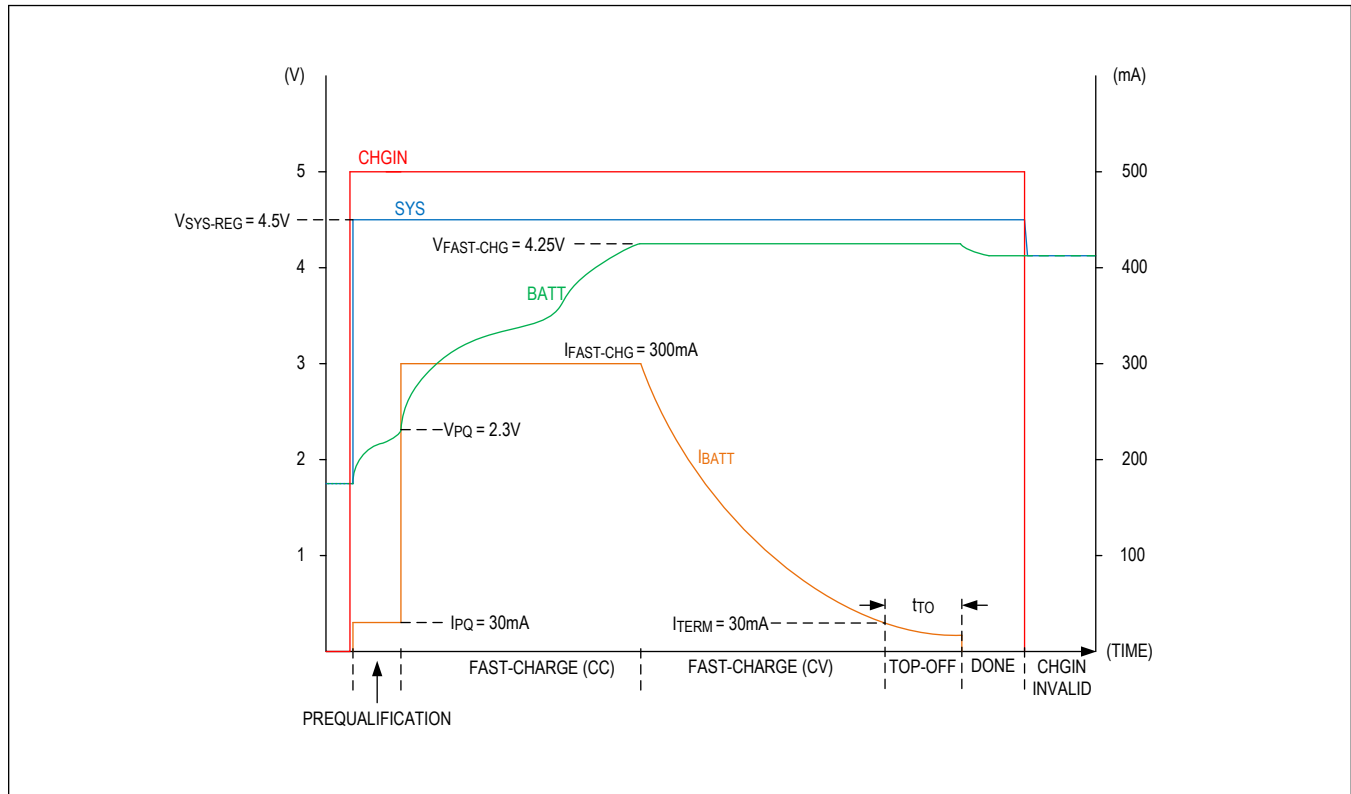

Figure 16. Example Battery Charge Profile

Charger Applications Information

Configuring a Valid System Voltage

The Smart Power Selector begins to regulate SYS to $V_{\text{SYS-REG}}$ when CHGIN is connected to a valid source. To ensure the charger's accuracy specified in the [Electrical Characteristics](#) table, the system voltage must always be programmed at least 200mV above the charger's constant-voltage level ($V_{\text{FAST-CHG}}$). If this condition is not met, then the charger's internal configuration logic forces $V_{\text{FAST-CHG}}$ to reduce to satisfy the 200mV requirement. If this happens, the charger asserts the INT_CHG.SYS_CNFG_I interrupt to alert the user that a configuration error has been made and that the bits in CNFG_CHG_G.CHG_CV[5:0] have changed to reduce $V_{\text{FAST-CHG}}$.

CHGIN/SYS/BATT Capacitor Selection

Bypass CHGIN to GND with a 4.7 μF ceramic capacitor to minimize inductive kick caused by long cables between the DC charge source and the product/IC. Larger values increase decoupling for the linear charger, but increase inrush current from the DC charge source when the product/IC is first connected to a source through a cable/plug. If the DC charging source is an upstream USB device, limit the maximum CHGIN input capacitance based on the appropriate USB specification (typically no more than 10 μF).

Bypass SYS to GND with a 22 μ F ceramic capacitor. This capacitor ensures stability of SYS while it is regulated from CHGIN. Larger values of SYS capacitance increase decoupling for all SYS loads. The effective value of the SYS capacitor must be greater than 4 μ F and no more than 100 μ F.

Bypass BATT to GND with a 4.7 μ F ceramic capacitor. This capacitor stabilizes the BATT voltage regulation loop. The effective value of the BATT capacitor must be greater than 1 μ F.

Ceramic capacitors with X5R or X7R dielectric are highly recommended due to their small size, low ESR, and small temperature coefficients. All ceramic capacitors derate with DC bias voltage (effective capacitance goes down as DC bias goes up). Generally, small case size capacitors derate heavily compared to larger case sizes (0603 case size performs better than 0402). Consider the effective capacitance value carefully by consulting the manufacturer's data sheet.

Detailed Description—Adjustable Thermistor Temperature Monitors

The optional use of a negative temperature coefficient (NTC) thermistor (thermally coupled to the battery) enables the charger to operate safely over the JEITA temperature range. When the thermistor is enabled (CNFG_CHG_F.THM_EN = 1), the charger continuously monitors the voltage at the THM pin in order to sense the temperature of the battery being charged.

See [Figure 17](#) for a visual example of the following:

- If the battery temperature is higher than T_{COOL} and lower than T_{WARM} , the battery charges normally with the normal values for $V_{FAST-CHG}$ and $I_{FAST-CHG}$. The charger state machine does not enter JEITA-modified states while the battery temperature is normal.
- If the battery temperature is either above T_{WARM} but below T_{HOT} , or, below T_{COOL} but above T_{COLD} , the battery charges with the JEITA-modified voltage and current values. These modified values, $V_{FAST-CHG_JEITA}$ and $I_{FAST-CHG_JEITA}$, are programmable through CNFG_CHG_H.CHG_CV_JEITA[5:0] and CNFG_CHG_F.CHG_CC_JEITA[5:0], respectively. These values are independently programmable from the unmodified $V_{FAST-CHG}$ and $I_{FAST-CHG}$ values and can even be programmed to the same values if an automatic response to a warm or cool battery is not desired. The charger state machine enters JEITA-modified states while the battery temperature is outside of normal.
- If the battery temperature is either above T_{HOT} or below T_{COLD} , the charger follows the JEITA recommendation and pauses charging. The charger state machine enters battery temperature fault state while charging is paused due to extreme high or low temperatures.

The battery's temperature status is reflected by the STAT_CHG_A.THM_DTLS[2:0] status bitfield. A maskable interrupt (INT_CHG.THM_I) signals a change in status. See the [Register Map](#) for more information. To completely disable the charger's automatic response to battery temperature, disable the feature by programming CNFG_CHG_F.THM_EN = 0.

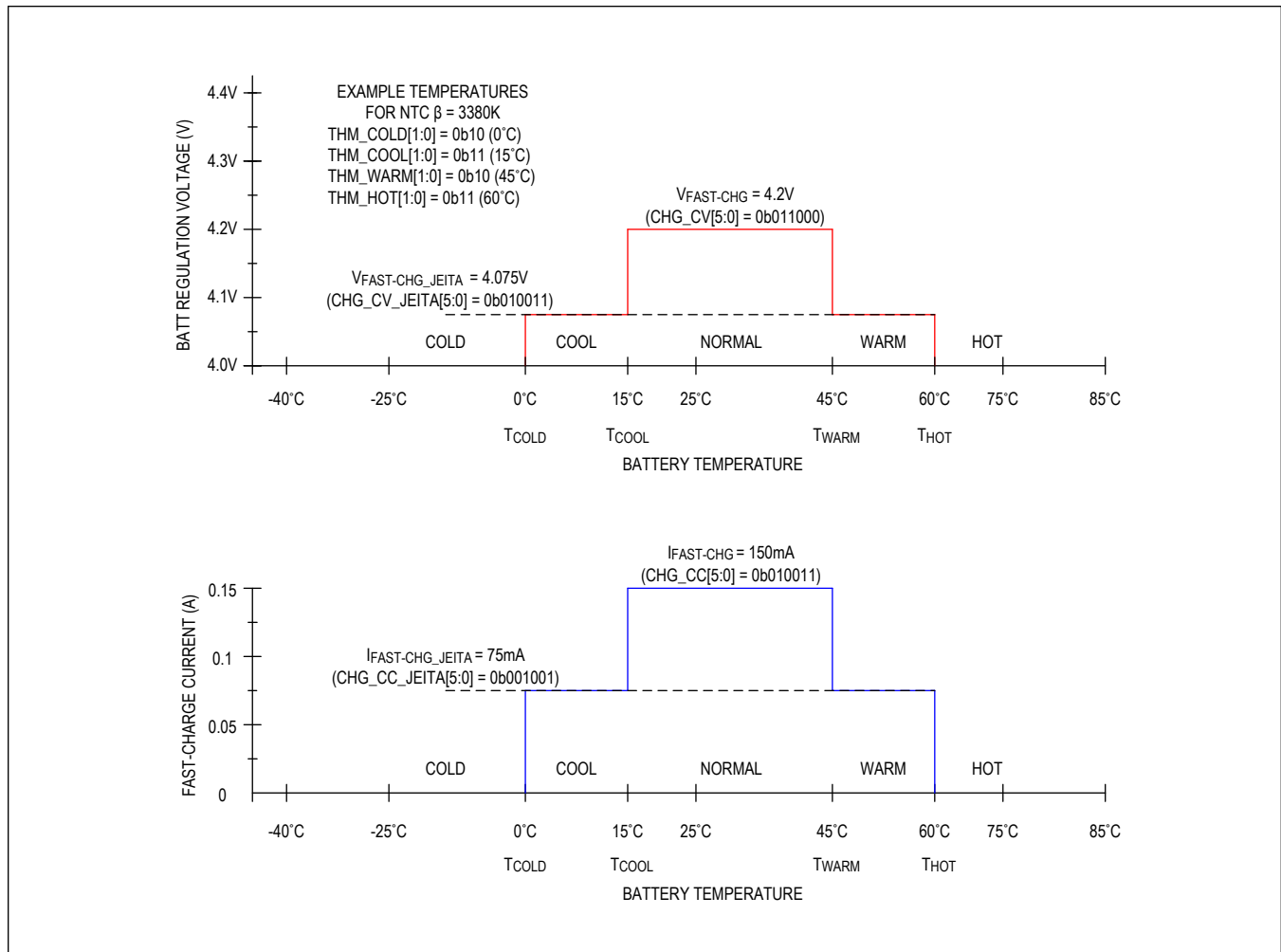

Figure 17. Safe-Charging Profile Example

The voltage thresholds corresponding to the JEITA temperature thresholds are independently programmable through CNFG_CHG_A.THM_HOT[1:0], CNFG_CHG_A.THM_WARM[1:0], CNFG_CHG_A.THM_COOL[1:0], and CNFG_CHG_A.THM_COLD[1:0]. Each threshold can be programmed to one of four voltage options spanning 15°C for an NTC beta of 3380K. See the [Configurable Temperature Thresholds](#) section and the [Register](#) for more information.

Thermistor Bias

An external ADC can optionally perform conversions on the THM and TBIAS pins to measure the battery's temperature. An on-chip analog multiplexer is used to route these nodes to the AMUX pin. The operation of the analog multiplexer does not interfere with the charger's temperature monitoring comparators or the charger's automatic JEITA response. See the [Analog Multiplexer](#) section for more information.

The NTC thermistor's bias source (TBIAS) follows the simple operation outlined below:

- If CHGIN is valid and the thermistor is enabled (CNFG_CHG_F.THM_EN = 1), the thermistor is biased, so the charger can automatically respond to battery temperature changes.
- If the analog multiplexer connects THM or TBIAS to AMUX, then the thermistor is biased, so an external ADC can perform a meaningful temperature conversion.

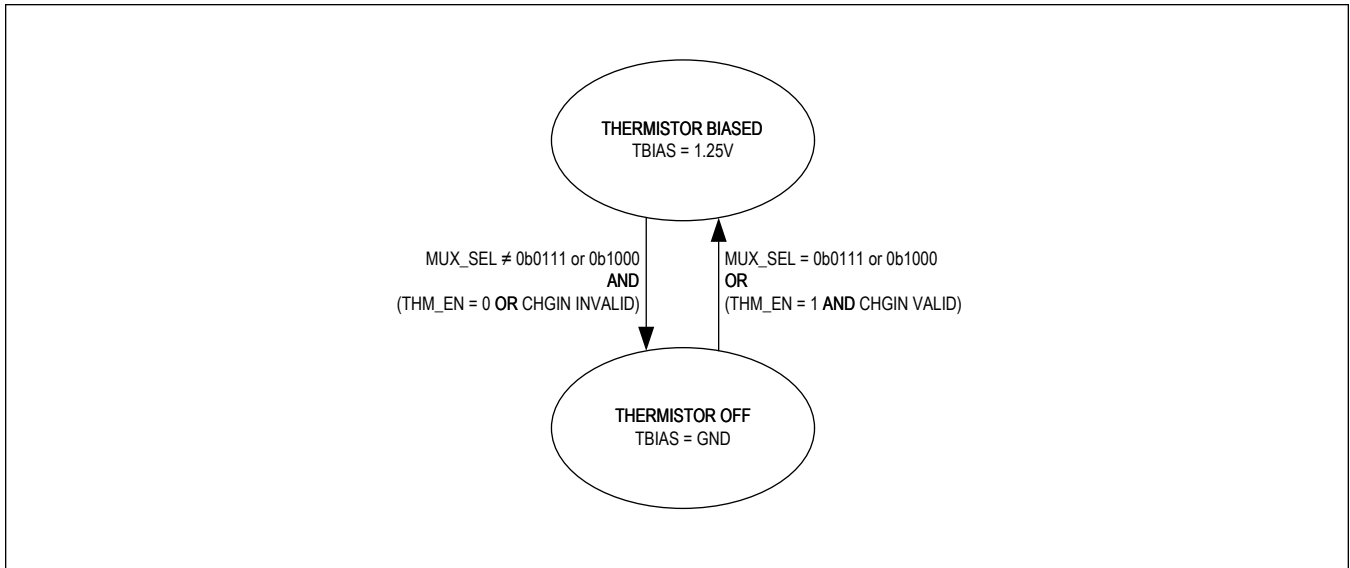

Figure 18. Thermistor Bias State Diagram

The AMUX pin is a buffered output. The operation of the analog multiplexer and external ADC does not collide with the function of the on-chip temperature monitors. Both functions may be used simultaneously with no ill effect.

Configurable Temperature Thresholds

Temperature thresholds for different NTC thermistor beta values are listed in [Table 10](#). The largest possible programmable temperature range can be realized by using an NTC with a beta of 3380K. Using a larger beta compresses the temperature range. The trip voltage thresholds are programmable with the CNFG_CHG_A.THM_HOT[1:0], CNFG_CHG_A.THM_WARM[1:0], CNFG_CHG_A.THM_COOL[1:0], and CNFG_CHG_A.THM_COLD[1:0] bitfields. All possible programmable trip voltages are listed in [Table 10](#).

Table 10. Trip Temperatures vs. Trip Voltages for Different NTC β

TRIP VOLTAGE (V)	TRIP TEMPERATURES (°C)					
	3380K	3435K	3940K	4050K	4100K	4250K
1.024	-10.0	-9.5	-5.6	-4.8	-4.5	-3.5
0.976	-5.0	-4.6	-1.1	-0.5	-0.2	0.6
0.923	0.0	0.3	3.3	3.8	4.1	4.8
0.867	5.0	5.3	7.7	8.1	8.3	8.9
0.807	10.0	10.2	12.0	12.4	12.5	12.9
0.747	15.0	15.1	16.4	16.6	16.7	17.0
0.511	35.0	34.8	33.5	33.3	33.2	32.9
0.459	40.0	39.8	37.8	37.4	37.3	36.8
0.411	45.0	44.7	42.0	41.5	41.3	40.7
0.367	50.0	49.6	46.2	45.6	45.3	44.6
0.327	55.0	54.5	50.4	49.7	49.3	48.4
0.291	60.0	59.4	54.6	53.7	53.3	52.2

These are theoretical values computed by a formula. Refer to the particular NTC's data sheet for more accurate measured data. In all cases, select the value of R_{BIAS} to be equal to the NTC's effective resistance at +25°C.

Applications Information

Using Different Thermistor β

If an NTC with a beta larger than 3380K is used and the resulting available programmable temperature range is undesirably small, then two adjusting resistors can be used to expand the temperature range. R_S and R_P can be optionally added to the NTC thermistor circuit shown in [Figure 19](#) to expand the range of programmable temperature thresholds.

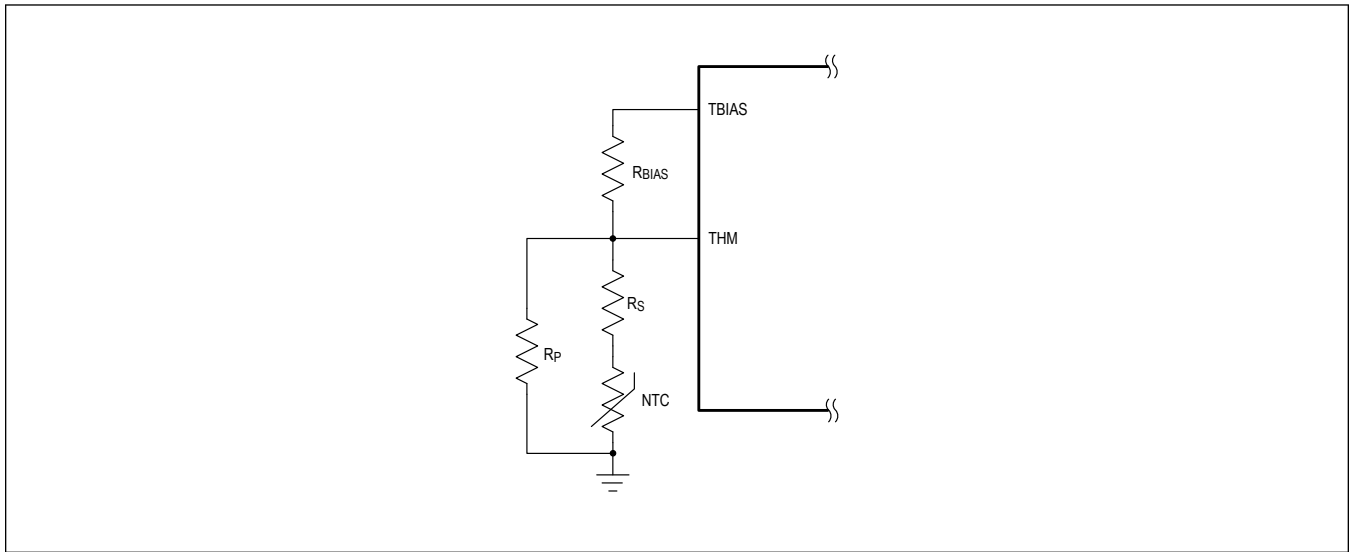

Figure 19. Thermistor Circuit with Adjusting Series and Parallel Resistors

Select values for R_S and R_P based on the information shown in [Table 11](#).

Table 11. Example R_S and R_P Correcting Values for NTC β Above 3380K

PARAMETER	UNIT	TARGET NTC CASE	CASE 1		CASE 2		CASE 3	
NTC thermistor beta	K	3380	3940		4050		4250	
25°C NTC resistance	k Ω	10	10		47		100	
R_{BIAS}		10	10		47		100	
Adjusting parallel resistor, R_P		open	open	200	open	680	open	1300
Adjusting series resistor, R_S		short	short	0.62	short	3.3	short	9.1
R_{NTC} at 1.024V _{COOL} threshold		45.24	45.24	578.5	212.6	306.1	452.4	684.8
R_{NTC} at 0.867V _{COOL} threshold		22.61	22.61	248.8	106.3	122.7	226.1	264.7
R_{NTC} at 0.459V _{WARM} threshold		5.81	5.81	5.36	27.3	25.1	58.1	51.7
R_{NTC} at 0.291V _{HOT} threshold		3.04	3.04	2.46	14.3	112.7	30.4	22.0
T_{ACTUAL} at V _{COOL} (-10°C expected)	°C	-10.03	-5.56	-9.96	-4.82	-11.14	-3.55	-10.46
T_{ACTUAL} at V _{COOL} (5°C expected)		4.98	7.66	5.76	8.10	5.33	8.86	5.94
T_{ACTUAL} at V _{WARM} (40°C expected)		40.02	37.79	39.76	37.43	39.40	36.82	39.48
T_{ACTUAL} at V _{HOT} (60°C expected)		60.04	54.56	60.37	53.68	60.02	52.21	60.4

NTC Thermistor Selection

Popular NTC thermistor options are listed in [Table 12](#).

Table 12. NTC Thermistors

MANUFACTURER	PART	β -CONSTANT (25°C/50°C)	R (Ω) AT 25°C	CASE SIZE
TDK	NTCG063JF223HTBX	3380K	22k	0201
Murata	NCP03XH103F05RL	3380K	10k	0201
Murata	NCP15XH103F03RC	3380K	10k	0402
TDK	NTCG103JX103DT1	3380K	10k	0402
Cantherm	CMFX3435103JNT	3435K	10k	0402
Murata	NCP15XV103J03RC	3900K	10k	0402
Panasonic	ERT-JZEP473J	4050K	47k	0201
Panasonic	ABNTC-0402-473J-4100F-T	4100K	47k	0402
Murata	NCP15WF104F03RC	4250K	100k	0402

Detailed Description—Analog Multiplexer

An external ADC can be used to measure the chip's various signals for general functionality or on-the-fly power monitoring. The CNFG_CHG_I.MUX_SEL[3:0] bitfield controls the internal analog multiplexer responsible for connecting the proper channel to the AMUX pin. Each measurable signal is listed in [Table 13](#) with its appropriate multiplexer channel.

The voltage on the AMUX pin is a buffered output that ranges from 0V to V_{FS} (1.25V, typ). The buffer has 50 μ A of quiescent current consumption and is only active when a channel is selected (CNFG_CHG_I.MUX_SEL[3:0] \neq 0b0000). Disable the buffer by programming CNFG_CHG_I.MUX_SEL[3:0] to 0b0000 when not actively converting the voltage on AMUX. The AMUX output is high-impedance while CNFG_CHG_I.MUX_SEL[3:0] is 0b0000.

[Table 13](#) shows how to translate the voltage signal on the AMUX pin to the value of the parameter being measured. See the *Electrical Characteristics* table and the [Register Map](#) for more details.

Table 13. AMUX Signal Transfer Functions

SIGNAL	MUX_SEL[3:0]	TRANSFER FUNCTION	FULL-SCALE SIGNAL MEANING ($V_{AMUX} = 1.25V$)	ZERO-SCALE SIGNAL MEANING ($V_{AMUX} = 0V$)
CHGIN pin voltage	0b0001	$V_{CHGIN} = \frac{V_{AMUX}}{G_{VCHGIN}}$	7.5V	0V
CHGIN pin current	0b0010	$I_{CHGIN} = \frac{V_{AMUX}}{G_{ICHGIN}}$	0.475A	0A
BATT pin voltage	0b0011	$V_{BATT} = \frac{V_{AMUX}}{G_{VBATT}}$	4.6V	0V
BATT pin charging current	0b0100	$I_{BATT(CHG)} = \frac{V_{AMUX}}{V_{FS}} \times I_{FAST-CHG}$	100% of $I_{FAST-CHG}$ (CHG_CC[5:0])	0% of $I_{FAST-CHG}$
BATT pin discharge current	0b0101	$I_{BATT(DISCHG)} = \frac{(V_{AMUX} - V_{NULL})}{(V_{FS} - V_{NULL})} \times I_{DISCHG-SCALE}$	100% of $I_{DISCHG-SCALE}$ (IMON_DISCHG_SCALE[3:0])	0% of $I_{DISCHG-SCALE}$

Table 13. AMUX Signal Transfer Functions (continued)

SIGNAL	MUX_SEL[3:0]	TRANSFER FUNCTION	FULL-SCALE SIGNAL MEANING (V _{AMUX} = 1.25V)	ZERO-SCALE SIGNAL MEANING (V _{AMUX} = 0V)
BATT pin discharge current NULL	0b0110	$V_{NULL} = V_{AMUX}$	1.25V	0V
THM pin voltage	0b0111	$V_{THM} = V_{AMUX}$	1.25V	0V
TBIAS pin voltage	0b1000	$V_{TBIAS} = V_{AMUX}$	1.25V	0V
AGND pin voltage*	0b1001	$V_{AGND} = V_{AMUX}$	1.25V	0V
SYS pin voltage	0b1010	$V_{SYS} = \frac{V_{AMUX}}{G_{V_{SYS}}}$	4.8V	0V

*AGND pin voltage is accessed through a 100Ω (typ) pulldown resistor.

Measuring Battery Current

Sampling current in the BATT pin is possible at any time or in any mode with an external ADC. For improved accuracy, the analog circuitry used for monitoring battery discharge current is different from the circuitry monitoring battery charge current. [Table 14](#) outlines how to determine the direction of battery current.

Table 14. Battery Current Direction Decode

MEASUREMENT	CHARGING OR DISCHARGING INDICATORS		
	STAT_CHG_B.CHG	STAT_CHG_B.CHG_DTLS[3:0]	STAT_CHG_B.CHG_IN_DTLS[1:0]
Discharging Battery Current (Positive Battery Terminal Sourcing Current)	<i>Don't care</i>	<i>Don't care</i>	0b00 0b01 0b10
Charging Battery Current (Positive Battery Terminal Sinking Current)	1	0b0001 to 0b0111	0b11

Method for Measuring Discharge Current

1. Program the multiplexer to switch to the discharge NULL measurement by changing CNFG_CHG_I.MUX_SEL[3:0] to 0b0110. A NULL conversion must always be performed first to cancel offsets.
2. Wait the appropriate channel switching time (0.3μs, typ).
3. Convert the voltage on the AMUX pin and store as V_{NULL}.
4. Program the multiplexer to switch to the battery discharge current measurement by changing CNFG_CHG_I.MUX_SEL[3:0] to 0b0101. A nonnulling conversion should be done immediately after a NULL conversion.
5. Wait the appropriate channel switching time (0.3μs, typ).
6. Convert the voltage on the AMUX pin and use the following transfer function to determine the discharge current:

$$I_{BATT(DISCHG)} = \frac{(V_{AMUX} - V_{NULL})}{(V_{FS} - V_{NULL})} \times I_{DISCHG - SCALE}$$

V_{FS} is 1.25V typical. I_{DISCHG-SCALE} is programmable through CNFG_CHG_I.IMON_DISCHG_SCALE[3:0]. The

default value is 300mA. If smaller currents are anticipated, then $I_{\text{DISCHG-SCALE}}$ can be reduced for improved measurement accuracy.

Method for Measuring Charge Current

1. Program the multiplexer to switch to the charge current measurement by changing `CNFG_CHG_I.MUX_SEL[3:0]` to `0b0100`.
2. Wait the appropriate channel switching time (0.3µs, typ).
3. Convert the voltage on the AMUX pin and use the following transfer function to determine charging current.

$$I_{\text{BATT(CHG)}} = \frac{V_{\text{AMUX}}}{V_{\text{FS}}} \times I_{\text{FAST-CHG}}$$

V_{FS} is 1.25V typical. $I_{\text{FAST-CHG}}$ the charger's fast-charge constant-current setting and is programmable through `CNFG_CHG_E.CHG_CC[5:0]`.

Detailed Description—SIMO Buck-Boost

The device has a micropower single-inductor, multiple-output (SIMO) buck-boost DC-to-DC converter designed for applications that emphasize low supply current and small solution size. A single inductor is used to regulate three separate outputs, saving board space while delivering better total system efficiency than equivalent power solutions using one buck and linear regulators.

The buck-boost configuration utilizes the entire battery voltage range due to its ability to create output voltages that are above, below, or equal to the input voltage. Peak inductor current for each output is programmable to optimize the balance between efficiency, output ripple, EMI, PCB design, and load capability.

To further boost efficiency when the output voltage is always lower than the input, individual channels of the SIMO buck-boost converter can be configured to be in buck mode, reducing switching losses by toggling less switches compared to buck-boost mode. See the [Buck Mode](#) section for more details.

SIMO Features and Benefits

- Three Output Channels
- Ideal for Low-Power Designs
 - Delivers 500mA at 1.8V Output in Buck Mode and 3.7V Input
 - ±3% Accurate Output Voltage
- Small Solution Size
 - Multiple Outputs from a Single 1.5µH Inductor
- Flexible and Easy to Use
 - Buck and Buck-Boost Modes of Operation
 - Glitchless Transitions Between Buck and Buck-Boost Modes
 - Programmable Peak Inductor Current
 - Programmable On-Chip Active Discharge
- Long Battery Life
 - High Efficiency, > 90% at 1.8V Output in Buck Mode and 3.7V Input
 - Higher Total System Efficiency than Buck + LDOs Solution
 - Low Quiescent Current, 1µA per Output
 - Low Input Operating Voltage, 2.7V (min)

SIMO Detailed Block Diagram

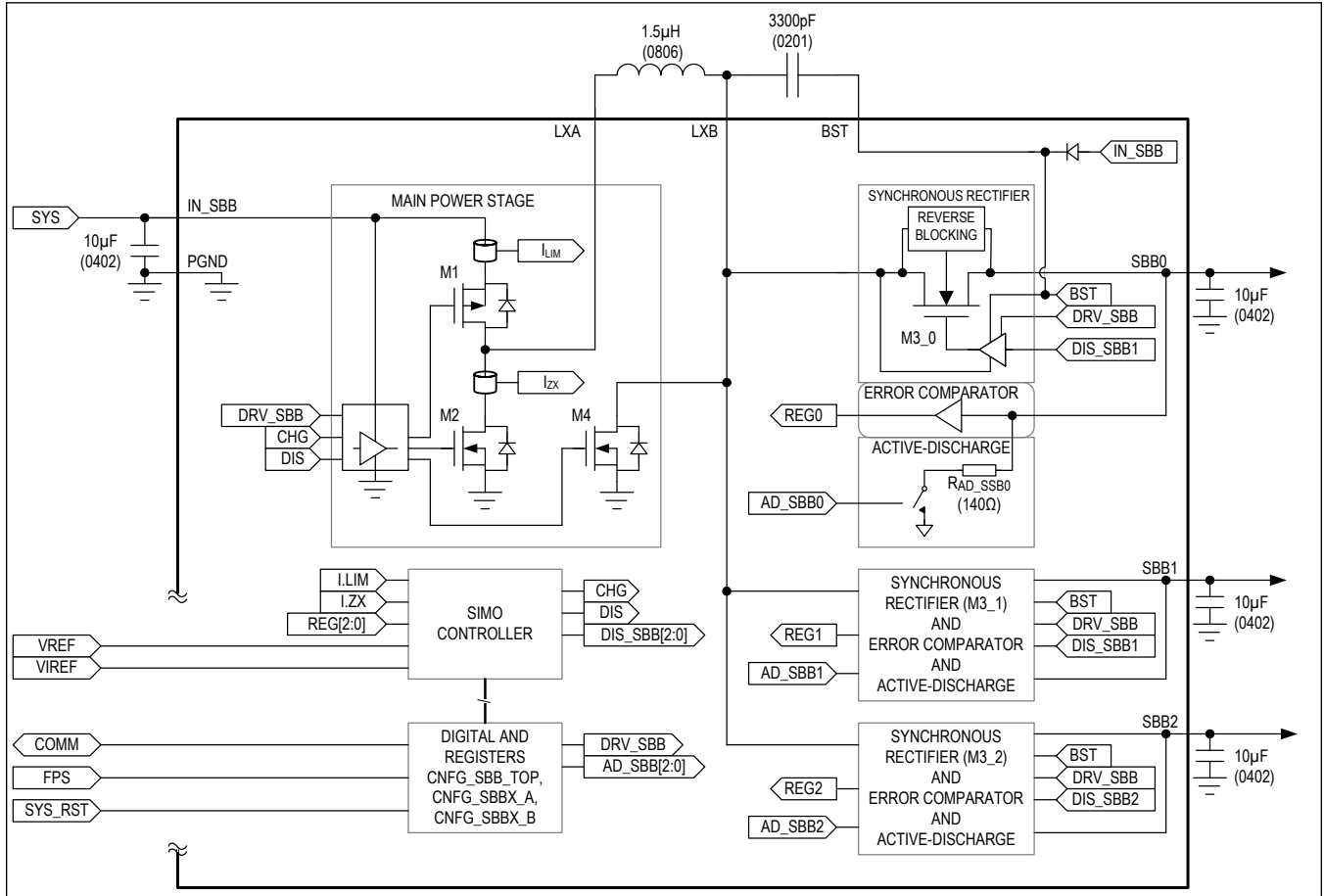

Figure 20. SIMO Detailed Block Diagram

SIMO Control Scheme

The SIMO buck-boost is designed to service multiple outputs simultaneously. A proprietary controller ensures that all outputs get serviced in a timely manner, even while multiple outputs are contending for the energy stored in the inductor. When no regulator needs service, the state machine rests in a low-power rest state.

When the controller determines that a regulator requires service, it charges the inductor (M1 + M4) until the peak current limit is reached ($I_{LIM} = CNFG_SBBx_B.IP_SBB[1:0]$). The inductor energy then discharges (M2 + M3_x) into the output until the current reaches zero (I_{ZX}). In the event that multiple output channels need servicing at the same time, the controller ensures that no output utilizes all of the switching cycles. Instead, cycles interleave between all the outputs that are demanding service, while outputs that do not need service are skipped.

Drive Strength

The SIMO regulator's drive strength for its internal power MOSFETs is adjustable using the CNFG_SBB_TOP.DRV_SBB[1:0] bit field. The ideal value is determined experimentally for each application. For a PCB layout comparable to the MAX77654 EV kit, 0x1 is the best setting and represents a balance between efficiency and EMI. Faster settings result in higher efficiency but generally require stricter layout rules or shielding to avoid additional EMI. Slower settings limit EMI in non-ideal settings (e.g., contained layout, antennae adjacent to the device, etc.). Change the drive strength only once during system initialization.

SIMO Soft-Start

The soft-start feature of the SIMO limits inrush current during startup. The soft-start feature is achieved by limiting the slew rate of the output voltage during startup (dV/dt_{SS}).

More output capacitance results in higher input current surges during startup. The following set of equations and example describes the input current surge phenomenon during startup.

In buck-boost mode, the current into the output capacitor (I_{CSBB}) during soft-start is:

$$I_{CSBB} = C_{SBB} \frac{dV}{dt_{SS}} \left(\text{Equation 1} \right)$$

where:

- C_{SBB} is the capacitance on the output of the regulator
- dV/dt_{SS} is the voltage change rate of the output

The input current (I_{IN}) during soft-start is:

$$I_{IN} = \frac{(I_{CSBB} + I_{LOAD}) \frac{V_{SBBx}}{V_{IN}}}{\xi} \left(\text{Equation 2} \right)$$

where:

- I_{CSBB} is from the calculation above
- I_{LOAD} is current consumed from the external load
- V_{SBBx} is the output voltage
- V_{IN} is the input voltage
- ξ is the efficiency of the regulator

For example, given the following conditions, the peak input current (I_{IN}) during soft-start is ~66.55mA:

Given:

- V_{IN} is 3.5V
- V_{SBB2} is 3.3V
- $C_{SBB2} = 10\mu\text{F}$
- $dV/dt_{SS} = 5\text{mV}/\mu\text{s}$
- $R_{LOAD2} = 330\Omega$ ($I_{LOAD2} = 3.3\text{V}/330\Omega = 10\text{mA}$)
- ξ is 85%

Calculation:

- $I_{CSBB} = 10\mu\text{F} \times 5\text{mV}/\mu\text{s}$ (from Equation 1)
- $I_{CSBB} = 50\text{mA}$
- $I_{IN} = \frac{(50\text{mA} + 10\text{mA}) \frac{3.3\text{V}}{3.5\text{V}}}{0.85}$ (from Equation 1)
- $I_{IN} \sim 66.55\text{mA}$

SIMO Registers

Each SIMO buck-boost channel has a dedicated register to program its target output voltage (CNFG_SBBx_A.TV_SBBx[6:0]) and its peak current limit (CNFG_SBBx_B.IP_SBBx[1:0]). Additional controls are available for enabling/disabling the active-discharge resistors (CNFG_SBBx_B.ADE_SBBx), buck mode (CNFG_SBBx_B.OP_MODE) as well as enabling/disabling the SIMO buck-boost channels (CNFG_SBBx_B.EN_SBBx[2:0]). For a full description of bits, registers, default values, and reset conditions, see the [Register Map](#).

SIMO Active Discharge Resistance

Each SIMO buck-boost channel has an active-discharge resistor (R_{AD_SBBx}) that is automatically enabled/disabled based on a CNFG_SBBx_B.ADE_SBBx bit and the status of the SIMO regulator. The active discharge feature may be enabled (CNFG_SBBx_B.ADE_SBBx = 1) or disabled (CNFG_SBBx_B.ADE_SBBx = 0) independently for each SIMO channel. Enabling the active discharge feature helps ensure a complete and timely power down of all system peripherals. If the active-discharge resistor is enabled by default, then the active-discharge resistor is on whenever V_{SYS} is below $V_{SYSUVLO}$ and above V_{POR} .

These resistors discharge the output when CNFG_SBBx_B.ADE_SBBx = 1, and their respective SIMO channel is off. If the regulator is forced on through CNFG_SBBx_B.EN_SBBx[2:0] = 0b110 or 0b111, then the resistors do not discharge the output even if the regulator is disabled by the main-bias.

Note that when V_{SYS} is less than 1.0V, the NMOS transistors that control the active-discharge resistors lose their gate drive and become open.

SIMO Buck Mode

If the input voltage at IN_SBB never falls below the output voltage of one or more SIMO converter channels, individual channels can be configured to be in buck mode with the CNFG_SBBx_B.OP_MODE bit. In buck mode, when an output needs service, switch M3_x remains closed and M4 remains open (see [Figure 20](#)). Only M1 and M2 are toggled as in a traditional buck converter. Efficiency is boosted due to three major factors:

- Reduced switching loss: Buck mode toggles only two switches versus the four in buck-boost mode. Therefore, there are less switching events during which power is consumed.
- Lower inductor core losses: Inductor current changes from 0A to peak current. The larger the change in current the inductor experiences, the more energy is lost in the inductor core in the form of heat. In buck mode, the peak current can be reduced since less inductor current is needed to support a load. Less inductor current is needed because of direct energy transfer. Direct energy transfer occurs while the inductor is charged, when the input (IN_SBB) is connected directly to the output (SBBx) through the inductor. Therefore, the input not only provides energy to charge the inductor, energy is also supplied to the output capacitor and load devices. Therefore, less current is needed to charge the inductor, which is used to charge the output capacitor in the next switching state.
- Less frequent charging cycles: In buck mode, the inductor is constantly connected to the serviced output during a switching cycle. In comparison, in buck-boost mode, the inductor is connected to the serviced output only when the inductor discharges. Thus, with the same peak inductor current limit, buck mode is capable of supplying higher load current than buck-boost mode. In addition, with the same load current and peak current limit, the switching frequency can be reduced with buck mode.

Maintain a minimum headroom of 0.7V between IN_SBB and SBBx in buck mode because inductor charge time ($dt = L \times I_{P_SBBx} / (V_{IN_SBB} - V_{SBBx})$) increases as the difference between the IN_SBB and SBBx voltages shrinks. As the inductor current takes longer to reach its peak, the output voltage may take too long to reach its target voltage, and the MAX77654 may trigger a fault flag.

Applications Information

SIMO Available Output Current

The available output current on a given SIMO channel is a function of the input voltage, output voltage, the peak current limit setting, and the output current of the other SIMO channels. Maxim offers a calculator (see the [Support Material](#) section) that outlines the available capacity for specific conditions. [Table 15](#) is an extraction from the calculator.

Table 15. SIMO Available Output Current for Common Applications

PARAMETERS	EXAMPLE 1	EXAMPLE 2	EXAMPLE 3	EXAMPLE 4
V _{IN_MIN}	2.7V	2.7V	3.2V	3.4V
R _{L_DCR}	0.1Ω	0.1Ω	0.1Ω	0.12Ω
SBB0	1.0V at 100mA	1.0V at 80mA	1.2V at 50mA	1.2V at 20mA
SBB1	1.2V at 75mA	1.2V at 50mA	1.8V at 100mA	1.8V at 80mA
SBB2	1.8V at 50mA	1.8V at 40mA	3.3V at 30mA	3.3V at 10mA
Operating Mode	Buck	Buck	Buck/Buck-Boost	Buck/Buck-Boost
I _{P_SBB0}	0.5A	0.5A	0.5A	0.5A
I _{P_SBB1}	0.75A	0.5A	0.5A	0.5A
I _{P_SBB2}	0.5A	0.5A	0.75A	0.5A
Utilized Capacity	78%	67%	76%	47%

*ESR_{C_IN} = ESR_{C_OUT} = 5mΩ, L = 1.5μH

Inductor Selection

Choose an inductance from 1.0μH to 2.2μH; 1.5μH inductors work best for most designs. Larger inductances transfer more energy to the output for each cycle and typically result in larger output voltage ripple and better efficiency. See the [Output Capacitor Selection](#) section for more information on how to size your output capacitor in order to control ripple.

Choose the inductor saturation current to be greater than or equal to the maximum peak current limit setting that is used for all of the SIMO buck-boost channels (I_{P_SBBx}). For example, if SBB0 is set for 0.5A, SBB1 is set for 0.75A, and SBB2 is set for 1.0A, then choose the saturation current to be greater than or equal to 1.0A.

Choose the RMS current rating of the inductor (typically the current at which the temperature rises appreciably) based on the expected load currents for the system. For systems where the expected load currents are not well known, be conservative and choose the RMS current to be greater than or equal to half the higher maximum peak current limit setting [$I_{RMS} \geq \text{MAX}(I_{P_SBB0}, I_{P_SBB1}, I_{P_SBB2})/\sqrt{3}$]. This is a conservative choice because the SIMO buck-boost regulator implements a discontinuous conduction mode (DCM) control scheme, which returns the inductor current to zero each cycle.

Consider the DC-resistance (DCR), AC-resistance (ACR), and solution size of the inductor. Typically, smaller sized inductors have larger DC-resistance and larger AC-resistance that reduces efficiency and the available output current. Note that many inductor manufacturers have inductor families which contain different versions of core material in order

to balance trade-offs between DCR, ACR (i.e., core losses), and component cost. For this SIMO regulator, inductors with the lowest ACR in the 1.0MHz to 2.0MHz region tend to provide the best efficiency.

[Table 16](#) shows inductors that follow the previously mentioned recommendations and yield good efficiency in a small form factor.

Table 16. Example Inductors

PART NUMBERS	INDUCTANCE	CASE CODE mm (in.)	THICKNESS
DFE201612E-1R0M	1.0μH	2016 (0806)	1.0mm
DFE201210U-1R5M	1.5μH	2012 (0805)	1.0mm
DFE201612E-1R5M	1.5μH	2016 (0806)	1.2mm
DFE201612E-2R2M	2.2μH	2012 (0806)	1.2mm
DFE201210S-2R2M	2.2μH	2012 (0805)	1.0mm

Input Capacitor Selection

Choose the input bypass capacitance (C_{IN_SBB}) to be 10μF. Larger values of C_{IN_SBB} improve the decoupling for the SIMO regulator.

C_{IN_SBB} reduces the current peaks drawn from the battery or input power source during SIMO regulator operation and reduces switching noise in the system. The ESR/ESL of the input capacitor should be very low (i.e., $ESR \leq 5m\Omega$ and $ESL \leq 500pH$) for frequencies up to 2MHz. Ceramic capacitors with X5R or X7R dielectric are highly recommended due to their small size, low ESR, and small temperature coefficients.

To fully utilize the available input voltage range of the SIMO (5.5V, max), use a capacitor with a voltage rating of 6.3V at minimum.

Boost Capacitor Selection

Choose the boost capacitance (C_{BST}) to be 3.3nF. Smaller values of C_{BST} (< 1nF) result in insufficient gate drive for M3. Larger values of C_{BST} (> 10nF) have the potential to degrade the startup performance. Ceramic capacitors with 0201 or 0402 case size are recommended.

Output Capacitor Selection

Choose each output bypass capacitance (C_{SBBx}) based on the target output voltage ripple (ΔV_{SBBx}): typical values are 22μF. Larger values of C_{SBBx} improve the output voltage ripple but increase the input surge currents during soft-start and output voltage changes. The output voltage ripple is a function of the inductance (L), the output voltage (V_{SBBx}), and the peak current limit setting (I_{P_SBBx}). See Equation 3 to estimate required, effective capacitance.

$$C_{SBBx} = \frac{I_{P_SBBx}^2 * L}{2 * V_{SBBx} * \Delta V_{SBBx}} \text{(Equation 3)}$$

Maxim also offers a calculator (see the [Support Materials](#) section) to aid in the selection of the output capacitance. Note that most designs concern themselves with having enough capacitance on the output but there is also a maximum capacitance limitation that is calculated within the SIMO calculator; take care not to exceed the maximum capacitance.

C_{SBBx} is required to keep the output voltage ripple small. The impedance of the output capacitor (ESR, ESL) should be very low (i.e., $ESR \leq 5m\Omega$ and $ESL \leq 500pH$) for frequencies up to 2MHz. Ceramic capacitors with X5R or X7R dielectric are highly recommended due to their small size, low ESR, and small temperature coefficients.

A capacitor's effective capacitance decreases with increased DC bias voltage. This effect is more pronounced as capacitor case sizes decrease. Due to this characteristic, it is possible for an 0603 case size capacitor to perform well, while an 0402 case size capacitor of the same value performs poorly. The SIMO regulator is stable with low output capacitance (1μF) but the output voltage ripple would be large; consider the effective output capacitance value after initial tolerance, bias voltage, aging, and temperature derating.

Example Component Selection

Pick input/output capacitors and the inductor for the given requirements:

- V_{IN_SBB} , typical = 3.7V

Table 17. Design Requirements

	SBB0	SBB1	SBB2
Output Voltage	3.3V	1.8V	1.2V
Maximum Load Current	50mA	60mA	80mA
Maximum Voltage Ripple	50mV	30mV	30mV

Inductor, Peak Current Limit, and Input Capacitor

For the best efficiency, a 2.2µH inductor is chosen. For this example, assume the DFE201612E-2R2M inductor from Murata is used. This particular inductor has 116mΩ of DCR.

Since the load current is low, first choose the inductor current peak to be 0.333A for all outputs. Next, enter these values into Maxim’s SIMO calculator as mentioned previously.

Symbol	Value	Unit	Per Channel Symbol	Per Channel Value			Unit
				SBB0	SBB1	SBB2	
Input Section							
V_{IN}	3.7000	V	V_{OUT}	3.300	1.800	1.200	V
L	2.20	µH	I_{OUT}	50.0	60.0	80.0	mA
r_{L_DCR}	116	mΩ	C_{OUT} Effective	8.1	13.8	16.8	µF
			r_{C_ESR}	5	5	5	mΩ
$T_{OPERATING}$	25	°C	Channel Enabled?	Yes	Yes	Yes	
Other Inputs							
Device	MAX77654		I_{L_Peak}	0.333	0.333	0.333	A
			Operating Mode	Buck-Boost	Buck	Buck	
Calculation Results							
Inductor Utilization							
Total Utilization	141.5%		Utilization	57.7%	35.7%	48.1%	
Current and Power							
Output Voltage Ripple							

Figure 21. Component Selection—High Utilization

As shown in Figure 21, the utilization is over 100%, which leads to output voltage droop. To lower utilization, increase the inductor peak current limits. For this example, 1A is used for SBB0 and 0.5A for SBB1 and SBB2. Figure 22 shows utilization less than 80%. Using 0.5A for the inductor peak current limit has the added benefit of increased efficiency.

Symbol	Value	Unit	Per Channel Symbol	Per Channel Value			Unit
				SBB0	SBB1	SBB2	
Input Section							
V _{IN}	3.7000	V	V _{OUT}	3.300	1.800	1.200	V
L	2.20	μH	I _{OUT}	50.0	60.0	80.0	mA
r _{L_DCR}	116	mΩ	C _{OUT} Effective	8.1	13.8	16.8	μF
			r _{C_ESR}	5	5	5	mΩ
T _{OPERATING}	25	°C	Channel Enabled?	Yes	Yes	Yes	
Other Inputs							
Device	MAX77654		I _{L_Peak}	1.000	0.500	0.500	A
			Operating Mode	Buck-Boost	Buck	Buck	
Calculation Results							
Inductor Utilization							
Total Utilization	75.6%		Utilization	19.9%	23.7%	32.0%	
Current and Power							
Output Voltage Ripple							

Figure 22. Component Selection—Final Current Peak Limits

To support the selected peak currents, choose 22μF for the input capacitor.

Output Capacitors

Using Equation 3 and the selected inductor current peak limits, the minimum output capacitances required are:

$$C_{SBB0_min} = \frac{I_{P_SBB0}^2 \times L}{2 \times V_{SBB0} \times \Delta V_{SBB0}} = \frac{1^2 \times 2.2 \times 10^{-6} \text{ A}^2 \times \text{H}}{2 \times 3.3 \times 0.05} = 6.67 \mu\text{F}$$

$$C_{SBB1_min} = \frac{I_{P_SBB1}^2 \times L}{2 \times V_{SBB1} \times \Delta V_{SBB1}} = \frac{0.5^2 \times 2.2 \times 10^{-6} \text{ A}^2 \times \text{H}}{2 \times 1.8 \times 0.03} = 5.09 \mu\text{F}$$

$$C_{SBB2_min} = \frac{I_{P_SBB2}^2 \times L}{2 \times V_{SBB2} \times \Delta V_{SBB2}} = \frac{0.5^2 \times 2.2 \times 10^{-6} \text{ A}^2 \times \text{H}}{2 \times 1.2 \times 0.03} = 7.64 \mu\text{F}$$

For this example, the 22μF GRM188R61A226ME15 is chosen for all three outputs. The effective capacitance after derating is the following:

$$C_{SBB0} = 8.113 \mu\text{F}$$

$$C_{SBB1} = 13.828 \mu\text{F}$$

$$C_{SBB2} = 16.793 \mu\text{F}$$

Go back to the calculator and enter the capacitance for each channel. [Figure 23](#) shows the expected ripples, which fit the requirements.

Symbol	Value	Unit	Per Channel Symbol	Per Channel Value			Unit
				SBB0	SBB1	SBB2	
Input Section							
V_{IN}	3.7000	V	V_{OUT}	3.300	1.800	1.200	V
L	2.20	μ H	I_{OUT}	50.0	60.0	80.0	mA
r_{L_DCR}	116	m Ω	C_{OUT} Effective	8.1	13.8	16.8	μ F
			r_{C_ESR}	5	5	5	m Ω
$T_{OPERATING}$	25	$^{\circ}$ C	Channel Enabled?	Yes	Yes	Yes	
Other Inputs							
Device	MAX77654		I_{L_Peak}	1.000	0.500	0.500	A
			Operating Mode	Buck-Boost	Buck	Buck	
Calculation Results							
Inductor Utilization							
Total Utilization	75.6%		Utilization	19.9%	23.7%	32.0%	
Current and Power							
Output Voltage Ripple							
			$V_{OUT_ripple_no_load}$	42.5	23.8	21.0	mV _{pp}
				1.3%	1.3%	1.8%	
			$V_{OUT_ripple_w_load}$	35.3	19.4	15.7	mV _{pp}
				1.1%	1.1%	1.3%	

Figure 23. Component Selection—Expected Ripple

Summary

- L = 2.2 μ H
- $C_{IN_SBB} = 22\mu$ F
- Total Switching Utilization = 76%

Table 18. Summary of Design for Component Selection Example

	SBB0	SBB1	SBB2
I_{P_SBBx}	1A	0.5A	0.5A
C_{SBBx} (nominal)	22 μ F	22 μ F	22 μ F
ΔV_{SBBx}	35.3mV	19.4mV	15.7mV

Real applications should also consider the minimum input voltage since the battery discharges. The following is a summary using the same components but an input voltage of 3.0V instead. The switching utilization increased to 77.1%, still below 80%.

- L = 2.2 μ H
- $C_{IN_SBB} = 22\mu$ F
- Total Switching Utilization = 77.1%

Table 19. Summary of Design with Lower Input Voltage

	SBB0	SBB1	SBB2
I _{P_SBBx}	1A	0.5A	0.5A
C _{SBBx} (nominal)	22μF	22μF	22μF
ΔV _{SBBx}	35.3mV	26.9mV	18.6mV

SIMO Switching Frequency

The SIMO buck-boost regulator uses a pulse frequency modulation (PFM) control scheme. The switching frequency for each output is a function of the operating mode, input voltage, output voltage, load current, and inductance. Output capacitance is a minor factor in SIMO switching frequency. Maxim offers a SIMO calculator (see the [Support Material](#) section) to estimate expected switching frequency.

At no load, switching frequencies can be as low as 10Hz. For the 3.7V input to 1.2V output channel from the [Example Component Selection](#) section, the switching frequency is about 327kHz.

[Table 20](#) lists how different factors increase or decrease switching frequency.

Table 20. Switching Frequency Control

FACTOR	INCREASING FREQUENCY	DECREASING FREQUENCY
Inductor Current Peak Limit	Lower peak limit	Higher peak limit
Operating Mode	Buck-boost mode	Buck mode
Inductor	Decrease inductance	Increase inductance
Output Capacitor	Decrease capacitance	Increase capacitance
Input Voltage	Higher voltage	Lower voltage
Output Voltage	Higher voltage	Lower voltage
Load Current	Higher current	Lower current

Unused Outputs

Do not leave unused outputs unconnected. If an output left unconnected is accidentally enabled, the charged inductor experiences an open circuit, and the output voltage soars above the absolute maximum rating, damaging the device. If an output is not used, do one of the following:

1. Disable the output (CNFG_SBBx_B.EN_SBBx[2:0] = 0x4 or 0x5) and connect the output to ground. If an unused output is default enabled or can be accidentally enabled, do one of the following recommendations instead.
2. Bypass the unused output with a 1μF capacitor to ground.
3. Connect the unused output to IN_SBB or a different output channel if the unused output is programmed to a lower voltage. Since the output voltage is higher than the unused output, the regulator does not service the unused output even if it is unintentionally enabled.
 1. Note that some OTP options have the active-discharge resistors enabled by default. Connecting an unused output to IN_SBB is not recommended if the active discharge is enabled by default. If connecting the unused output to a different channel, disable the active-discharge resistor (CNFG_SBBx_B.ADE_SBBx = 0) of the unused channel.

PCB Layout Guide

Capacitors

Place decoupling capacitors as close as possible to the IC such that connections from capacitor pads to pin and from capacitor pads to ground pins are short. Keeping the connections short lowers parasitic inductance and resistance, improving performance and shrinking the physical size of hot loops.

If connections to the capacitors are through vias, use multiple vias to minimize parasitics. Also, connect loads to the capacitor pads rather than the device pins.

Most critical are the capacitors for the switching regulator: input capacitor at IN_SBB and output capacitors at SBBx.

Input Capacitor at IN_SBB

Minimize the parasitic inductance from PGND to input capacitor to IN_SBB to reduce ringing on the LXA voltage.

Output Capacitors at SBBx

The output capacitors experience large changes in current as the regulator charges (buck mode) and discharges (both modes) the inductor. In buck mode, the capacitor current ramps up at the same rate as mentioned in the previous section. In buck-boost mode, the capacitor current ramps up very quickly. In both modes, the capacitor current ramps down at a rate of $\frac{dI_{C_SBBx}}{dt} = \frac{V_{SBBx}}{L}$ from inductor peak current. Since the ramp down can occur in less than 1 μ s, and the current increases rapidly for buck-boost mode, minimize parasitic inductance from SBBx to output capacitor to PGND.

Inductor

Keep the inductor close to the IC to reduce trace resistance; however, prioritize any regulator input/output capacitors over the inductor. Use the appropriate trace width from LXA to inductor to LXB to support the peak inductor current. Likewise, if there are vias in the path, use an appropriate amount of vias to support the peak current.

Ground Connections

As the switching regulator charges and discharges the inductor, current flows from PGND to the input capacitor ground, from output capacitor ground to PGND, or from output capacitor ground to input capacitor ground. Therefore, use a wide, continuous copper plane to connect PGND to the capacitor grounds.

When connecting the GND and PGND pins together, ensure noise from the power ground does not enter the analog ground (where GND is connected). For example, assuming the ground pins are connected through a solid ground plane on an internal layer, one via connecting GND to the internal ground plane may be sufficient to protect GND from most of the noise in the power-ground plane. Likewise, if there are other higher current or noisy circuitry near this device, avoid connecting the GND pin directly to their grounds.

For more guidelines on proper grounding, visit: <https://www.maximintegrated.com/en/design/partners-and-technology/design-technology/ground-layout-board-designers.html>.

Example PCB Layout

Figure 24 shows an example layout of the top layer.

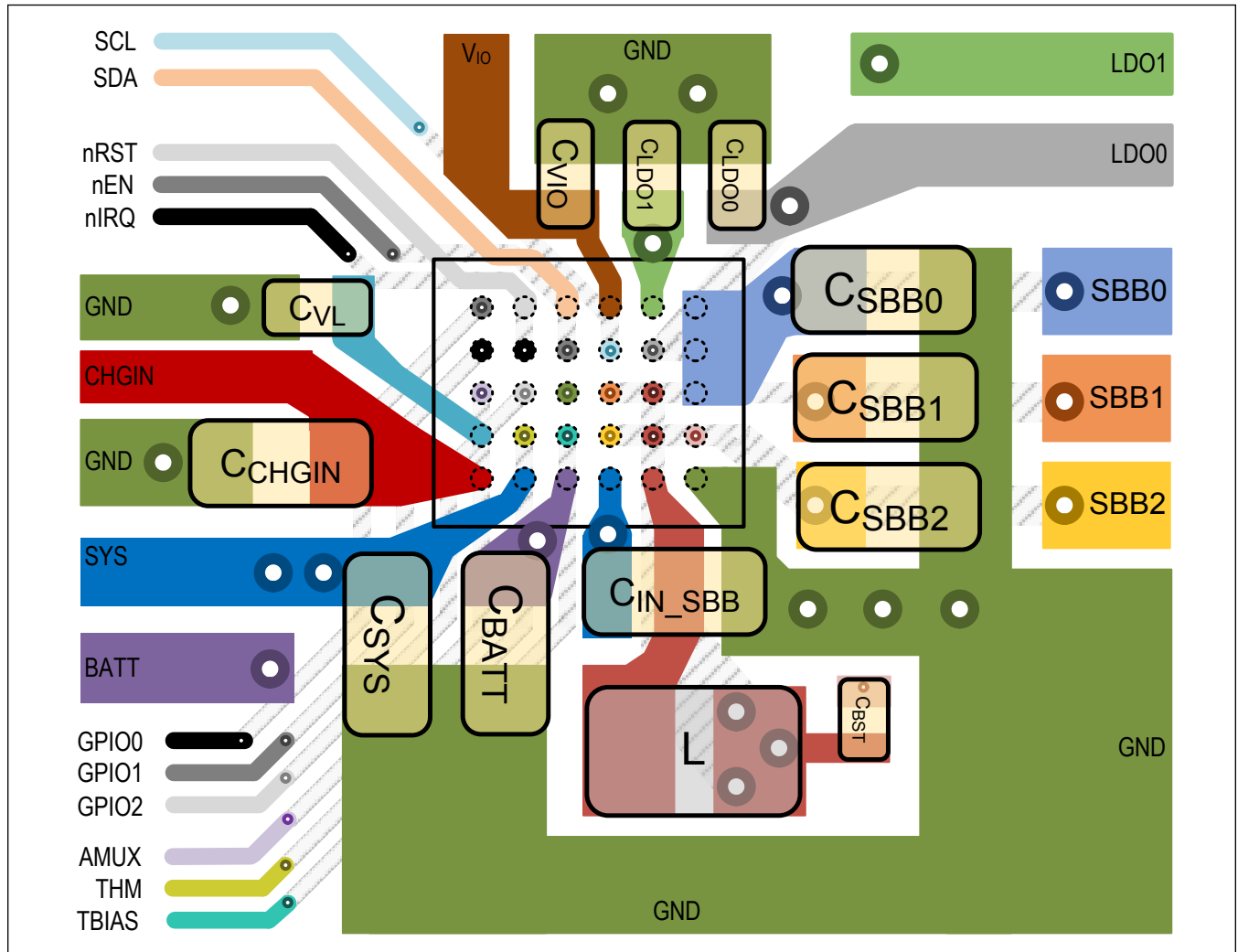

Figure 24. PCB Top-Layer and Component Placement Example

Detailed Description—Low Dropout Linear Regulator (LDO)/Load Switch (LSW)

The device includes two on-chip low-dropout linear regulators (LDO0/1) that can also be configured as load switches. These LDOs are optimized to have low-quiescent current. The input voltage range (V_{IN_LDOx}) allows it to be powered directly from the main energy source such as a Li-Poly battery or from an intermediate regulator. Each linear regulator delivers up to 100mA.

Features and Benefits

- 2x 100mA LDO
- LDO Input Voltage Range: 1.71V to 5.5V
- LSW Input Voltage Range: 1.3V to 5.5V
- Adjustable Output Voltage
- 100mV Maximum Dropout Voltage at ECT Conditions
- Programmable On-Chip Active Discharge

LDO/LSW Simplified Block Diagram

Each LDO/LSW block has one input (IN_LDOx) and one output ($LDOx$) and several ports that exchange information with the rest of the device (V_{REF} , EN_LDOx , ADE_LDOx). V_{REF} comes from the main bias circuits. $CNFG_LDOx_B.EN_LDOx$ and $CNFG_LDOx_B.ADE_LDOx$ are register bits for controlling the enable and active-discharge feature, respectively. See the [Register Map](#) for more information.

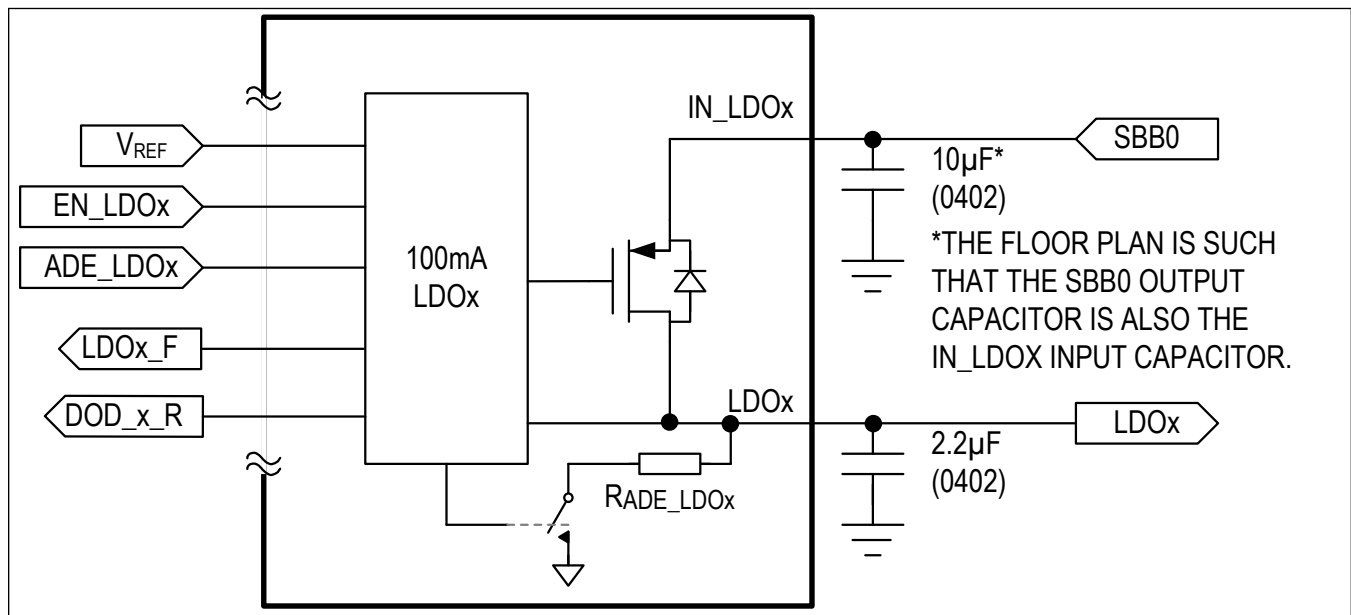

Figure 25. LDO Simplified Block Diagram

LDO/LSW Active-Discharge Resistor

Each LDO/LSW block has an active-discharge resistor (R_{AD_LDOx}) that is enabled if $CNFG_LDO_B.ADE_LDOx = 1$ and $LDOx$ is disabled. Enabling the active discharge feature helps ensure a complete and timely power down of the resource. During power up, if $V_{SYS} > V_{POR}$ and $CNFG_LDO_B.ADE_LDOx = 1$, the active-discharge resistor is enabled.

LDO/LSW Soft-Start

The soft-start feature limits inrush current during startup, and is achieved by limiting the slew rate of the output voltage during startup (dV_{OUT_LDOx}/dt_{SS}).

More output capacitance results in higher input current surges during startup. The equation and example describes the input current surge phenomenon during startup.

The input current (I_{IN_LDOx}) during soft-start is:

$$I_{IN_LDOx} = C_{LDOx} \frac{dV_{OUT_LDOx}}{dt_{SS}} + I_{OUT_LDOx}$$

where:

- C_{LDOx} is the capacitance on the output of the regulator
- dV_{OUT_LDOx}/dt_{SS} is the voltage change rate of the output

For example, given the following conditions, the input current (I_{IN_LDOx}) during soft start is 13.08mA:

Given:

- $C_{LDOx} = 2.2\mu\text{F}$
- $dV_{OUT_LDOx}/dt_{SS} = 1.4\text{mV}/\mu\text{s}$
- LDOx programmed to 1.85V
- $R_{LDOx} = 185\Omega$ ($I_{OUT_LDOx} = 1.85\text{V}/185\Omega = 10\text{mA}$)

Calculation:

- $I_{IN} = 2.2\mu\text{F} \times 1.4\text{mV}/\mu\text{s} + 10\text{mA}$
- $I_{IN} = 13.08\text{mA}$

Load Switch Configuration

Both LDO0 and LDO1 can be configured as load switches with the `CNFG_LDOx_B.LDOx_MD` bit. As shown in [Figure 26](#), the transition from LDO to LSW mode is controlled by a defined slew rate until dropout is detected. Once dropout is detected, the load switch is fully closed and the dropout interrupt flag (`INT_GLBL.DODx_R`) is set.

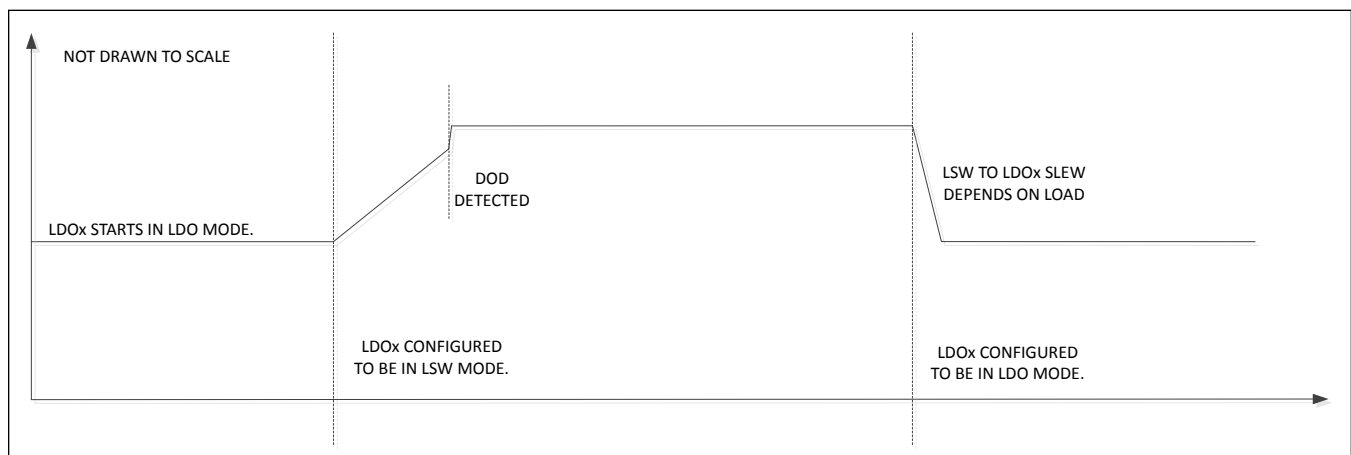

Figure 26. LDO to LSW Transition Waveform

Applications Information

Input Capacitor Selection

Make sure the input bypass capacitance (C_{IN_LDOx}) is at least $2.2\mu\text{F}$. Larger values of C_{IN_LDOx} improve the decoupling for LDOx. The floor plan of the device is such that SBB0 is adjacent to IN_LDOx and if the SIMO channel 0 output powers the input of LDOx, then its output capacitor (C_{SBB0}) can also serve as C_{IN_LDOx} such that only one capacitor is required.

C_{IN_LDOx} reduces the current peaks drawn from the battery or input power source during operation. The impedance of the input capacitor (ESR, ESL) should be very low (i.e., $\text{ESR} \leq 50\text{m}\Omega$ and $\text{ESL} \leq 5\text{nH}$) for frequencies up to 0.5MHz . Ceramic capacitors with X5R or X7R dielectric are highly recommended due to their small size, low ESR, and small temperature coefficients.

Output Capacitor Selection

For both LDO and LSW modes, choose the output bypass capacitance (C_{LDOx}) to be $1\mu\text{F}$.

In LDO mode, larger values of C_{LDOx} improve output PSRR but increase input surge currents during soft-start and output voltage changes. The effective output capacitance should not exceed $2.8\mu\text{F}$ to maintain stability.

While in LDO mode, C_{LDOx} is required to keep stability. The series inductance of the output capacitor and its series resistance should be low (i.e., $\text{ESR} \leq 10\text{m}\Omega$ and $\text{ESL} \leq 1\text{nH}$) for frequencies up to 0.5MHz . Ceramic capacitors with X5R or X7R dielectric are highly recommended due to their small size, low ESR, and small temperature coefficients.

A capacitor's effective capacitance decreases with increased DC bias voltage. This effect is more pronounced with smaller capacitor case sizes. Due to this characteristic, 0603 case size capacitors tend to perform well while 0402 case size capacitors of the same value perform poorly.

Detailed Description—I²C Serial Communication

General Description

The IC features a revision 3.0 I²C-compatible, 2-wire serial interface consisting of a bidirectional serial data line (SDA) and a serial clock line (SCL). This device acts as a slave-only device, relying on the master to generate a clock signal. SCL clock rates from 0Hz to 3.4MHz are supported.

I²C is an open-drain bus and therefore SDA and SCL require pullups. Optional resistors (24Ω) in series with SDA and SCL protect the device inputs from high-voltage spikes on the bus lines. Series resistors also minimize crosstalk and undershoot on bus signals.

[Figure 27](#) shows the functional diagram for the I²C based communications controller. For additional information on I²C, refer to the "I²C Bus Specification and User Manual" which is available for free through the internet.

Features

- I²C Revision 3.0 Compatible Serial Communications Channel
- 0Hz to 100kHz (Standard Mode)
- 0Hz to 400kHz (Fast Mode)
- 0Hz to 1MHz (Fast-Mode Plus)
- 0Hz to 3.4MHz (High-Speed Mode)
- Does not utilize I²C Clock Stretching

I²C Simplified Block Diagram

There are three pins (aside from GND) for the I²C-compatible interface. V_{IO} determines the logic level, SCL is the clock line, and SDA is the data line. Note that the interface does **not** have the ability to drive the SCL line.

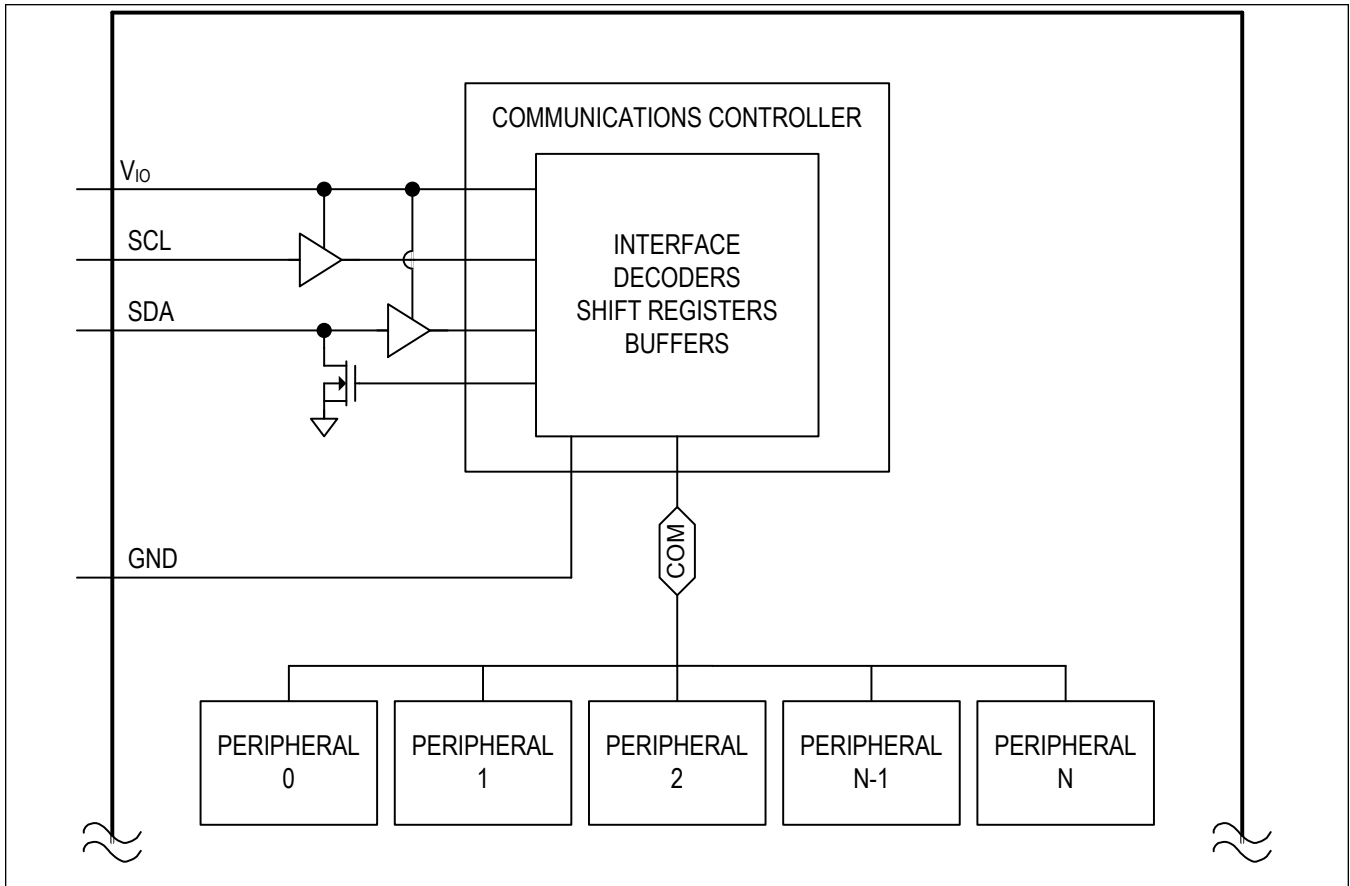

Figure 27. I²C Simplified Block Diagram

I²C System Configuration

The I²C-compatible interface is a multimaster bus. The maximum number of devices that can attach to the bus is only limited by bus capacitance.

A device on the I²C bus that sends data to the bus is called a transmitter. A device that receives data from the bus is called a receiver. The device that initiates a data transfer and generates the SCL clock signals to control the data transfer is a master. Any device that is being addressed by the master is considered a slave. The I²C-compatible interface operates as a slave on the I²C bus with transmit and receive capabilities.

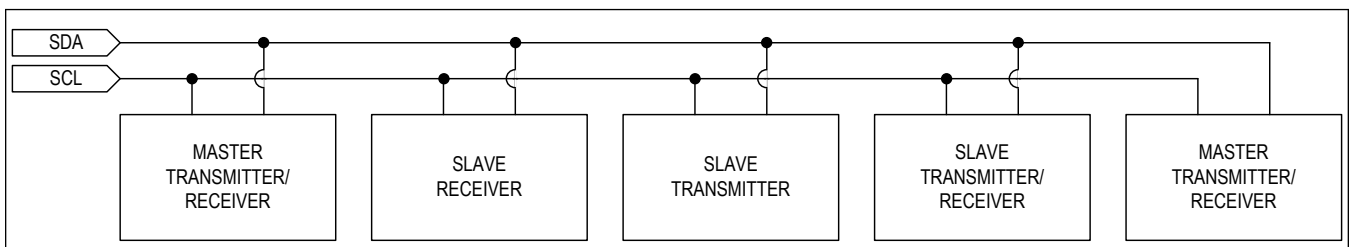

Figure 28. I²C System Configuration

I²C Interface Power

The I²C interface derives its power from V_{IO}. Typically a power input such as V_{IO} would require a local 0.1μF ceramic bypass capacitor to ground. However, in highly integrated power distribution systems, a dedicated capacitor might not be necessary. If the impedance between V_{IO} and the next closest capacitor (≥ 0.1μF) is less than 100mΩ in series with 10nH, then a local capacitor is not needed. Otherwise, bypass V_{IO} to GND with a 0.1μF ceramic capacitor.

V_{IO} accepts voltages from 1.7V to 3.6V (V_{IO}). Cycling V_{IO} does not reset the I²C registers. When V_{IO} is less than V_{IOUVLO} and V_{SYS} is less than V_{SYSUVLO}, SDA and SCL are high-impedance.

I²C Data Transfer

One data bit is transferred during each SCL clock cycle. The data on SDA must remain stable during the high period of the SCL clock pulse. Changes in SDA while SCL is high are control signals. See the [I²C Start and Stop Conditions](#) section. Each transmit sequence is framed by a START (S) condition and a STOP (P) condition. Each data packet is nine bits long: eight bits of data followed by the acknowledge bit. Data is transferred with the MSB first.

I²C Start and Stop Conditions

When the serial interface is inactive, SDA and SCL idle high. A master device initiates communication by issuing a START condition. A START condition is a high-to-low transition on SDA with SCL high. A STOP condition is a low-to-high transition on SDA, while SCL is high. See [Figure 29](#).

A START condition from the master signals the beginning of a transmission to the device. The master terminates transmission by issuing a not-acknowledge followed by a STOP condition (see the [I²C Acknowledge Bit](#) section for information on not-acknowledge). The STOP condition frees the bus. To issue a series of commands to the slave, the master can issue repeated start (Sr) commands instead of a STOP command to maintain control of the bus. In general a repeated start command is functionally equivalent to a regular start command.

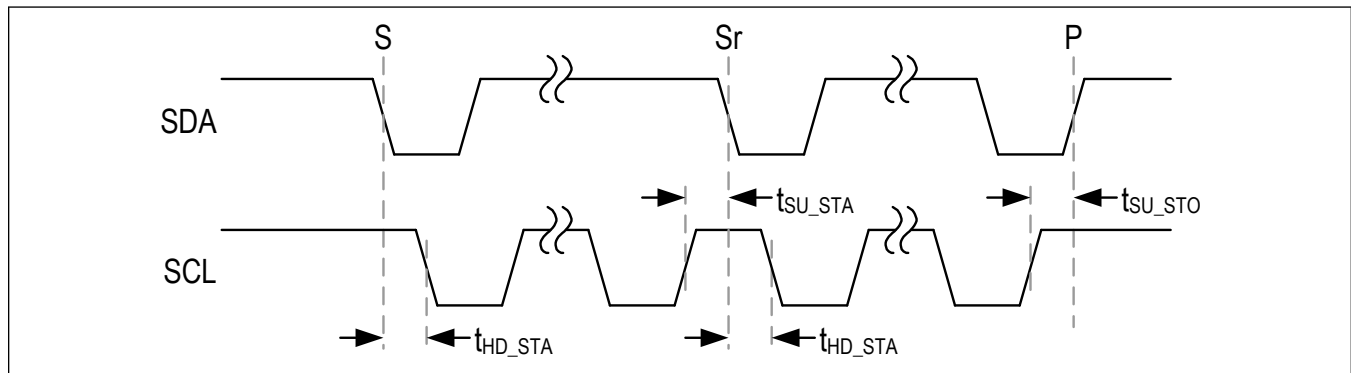

Figure 29. I²C Start and Stop Conditions

I²C Acknowledge Bit

Both the I²C bus master and slave devices generate acknowledge bits when receiving data. The acknowledge bit is the last bit of each nine bit data packet. To generate an acknowledge (A), the receiving device must pull SDA low before the rising edge of the acknowledge-related clock pulse (ninth pulse) and keep it low during the high period of the clock pulse. See [Figure 30](#). To generate a not-acknowledge (nA), the receiving device allows SDA to be pulled high before the rising edge of the acknowledge-related clock pulse and leaves it high during the high period of the clock pulse.

Monitoring the acknowledge bits allows for detection of unsuccessful data transfers. An unsuccessful data transfer occurs if a receiving device is busy or if a system fault has occurred. In the event of an unsuccessful data transfer, the bus master should reattempt communication at a later time.

This device issues an ACK for all register addresses in the possible address space even if the particular register does not exist.

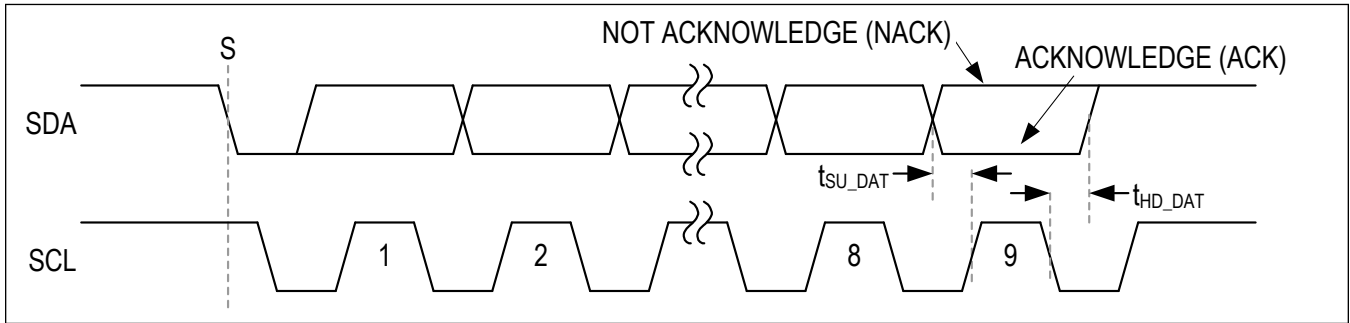

Figure 30. Acknowledge Bit

I²C Slave Address

The I²C controller implements 7-bit slave addressing. An I²C bus master initiates communication with the slave by issuing a START condition followed by the slave address. See Figure 31. The OTP address is factory-programmable for one of two options. See Table 21. All slave addresses not mentioned in Table 21 are not acknowledged.

Table 21. I²C Slave Address Options

ADDRESS	7-BIT SLAVE ADDRESS	8-BIT WRITE ADDRESS	8-BIT READ ADDRESS
Main Address (ADDR = 1)*	0x48, 0b 100 1000	0x90, 0b 1001 0000	0x91, 0b 1001 0001
Main Address (ADDR = 0)*	0x40, 0b 100 0000	0x80, 0b 1000 0000	0x81, 0b 1000 0001
Test Mode**	0x49, 0b 100 1001	0x92, 0b 1001 0010	0x93, 0b 1001 0011

*Perform all reads and writes on the main address. ADDR is a factory one-time programmable (OTP) option, allowing for address changes in the event of a bus conflict. [Contact Maxim](#) for more information.

**When test mode is unlocked, the additional address is acknowledged. Test mode details are confidential. If possible, leave the test mode address unallocated to allow for the rare event that debugging needs to be performed in cooperation with Maxim.

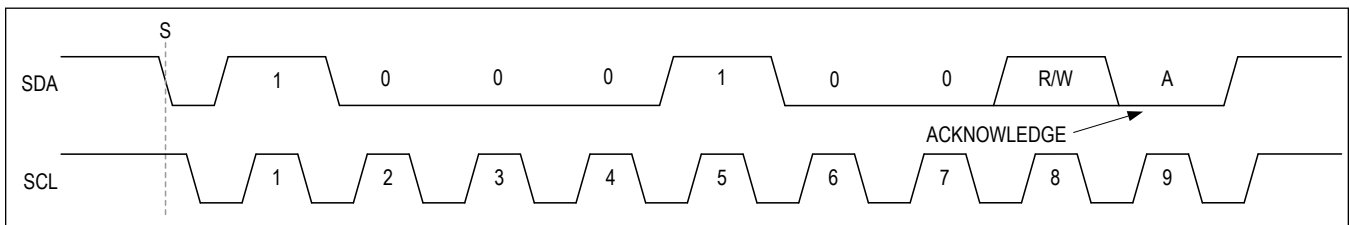

Figure 31. Slave Address Example

I²C Clock Stretching

In general, the clock signal generation for the I²C bus is the responsibility of the master device. The I²C specification allows slow slave devices to alter the clock signal by holding down the clock line. The process in which a slave device holds down the clock line is typically called clock stretching. The IC does not use any form of clock stretching to hold down the clock line.

I²C General Call Address

This device does not implement the I²C specifications general call address and does not acknowledge the general call address (0b0000_0000).

I²C Device ID

This device does not support the I²C Device ID feature.

I²C Communication Speed

This device is compatible with all four communication speed ranges as defined by the Revision 3.0 I²C specification:

- 0Hz to 100kHz (Standard Mode)
- 0Hz to 400kHz (Fast Mode)
- 0Hz to 1MHz (Fast-Mode Plus)
- 0Hz to 3.4MHz (High-Speed Mode)

Operating in standard mode, fast mode, and fast-mode plus does not require any special protocols. The main consideration when changing bus speed through this range is the combination of the bus capacitance and pullup resistors. Larger values of bus capacitance and pullup resistance increase the time constant ($C \times R$), slowing bus operation. Therefore, when increasing bus speeds, the pullup resistance must be decreased to maintain a reasonable time constant. Refer to the *Pullup Resistor Sizing* section of the I²C bus specification and user manual (available for free on the internet) for detailed guidance on the pullup resistor selection. In general for bus capacitances of 200pF, a 100kHz bus needs 5.6k Ω pullup resistors, a 400kHz bus needs about 1.5k Ω pullup resistors, and a 1MHz bus needs 680 Ω pullup resistors. Remember that, while the open-drain bus is low, the pullup resistor is dissipating power, and lower value pullup resistors dissipate more power (V^2/R).

Operating in high-speed mode requires some special considerations. For a full list of considerations, refer to the publicly available I²C bus specification and user manual. Major considerations with respect to this part are:

- The I²C bus master uses current source pullups to shorten the signal rise.
- The I²C slave must use a different set of input filters on its SDA and SCL lines to accommodate for the higher bus.
- The communication protocols need to utilize the high-speed master code.

At power-up and after each stop condition, the bus input filters are set for standard mode, fast mode, and fast-mode plus (i.e., 0Hz to 1MHz). To switch the input filters for high-speed mode, use the high-speed master code protocols that are described in the [I²C Communication Protocols](#) section.

I²C Communication Protocols

Both writing to and reading from registers are supported as described in the following subsections.

Writing to a Single Register

Figure 32 shows the protocol for the I²C master device to write one byte of data to this device. This protocol is the same as the SMBus specification's write byte protocol.

The write byte protocol is as follows:

1. The master sends a start command (S).
2. The master sends the 7-bit slave address followed by a write bit (R/W = 0).
3. The addressed slave asserts an acknowledge (A) by pulling SDA low.
4. The master sends an 8-bit register pointer.
5. The slave acknowledges the register pointer.
6. The master sends a data byte.
7. The slave updates with the new data.
8. The slave acknowledges or not acknowledges the data byte. The next rising edge on SDA loads the data byte into its target register and the data becomes active.
9. The master sends a stop condition (P) or a repeated start condition (Sr). Issuing a P ensures that the bus input filters are set for 1MHz or slower operation. Issuing an Sr leaves the bus input filters in their current state.

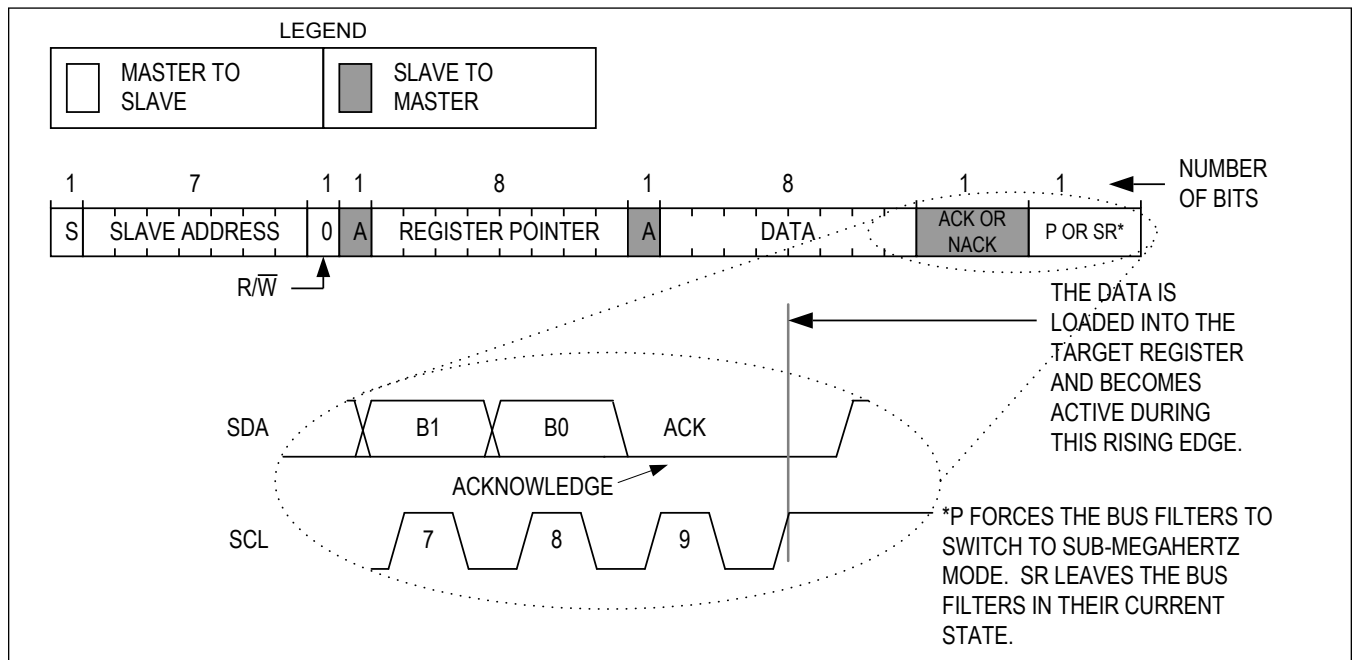

Figure 32. Writing to a Single Register with the Write Byte Protocol

Writing Multiple Bytes to Sequential Registers

[Figure 33](#) shows the protocol for writing to sequential registers. This protocol is similar to the write byte protocol, except the master continues to write after it receives the first byte of data. When the master is done writing, it issues a stop or repeated start.

The writing to sequential registers protocol is as follows:

1. The master sends a start command (S).
2. The master sends the 7-bit slave address followed by a write bit (R/W = 0).
3. The addressed slave asserts an acknowledge (A) by pulling SDA low.
4. The master sends an 8-bit register pointer.
5. The slave acknowledges the register pointer.
6. The master sends a data byte.
7. The slave acknowledges the data byte. The next rising edge on SDA loads the data byte into its target register and the data becomes active.
8. Steps 6 to 7 are repeated as many times as the master requires.
9. During the last acknowledge related clock pulse, the master can issue an acknowledge or a not acknowledge.
10. The master sends a stop condition (P) or a repeated start condition (Sr). Issuing a P ensures that the bus input filters are set for 1MHz or slower operation. Issuing an Sr leaves the bus input filters in their current state.

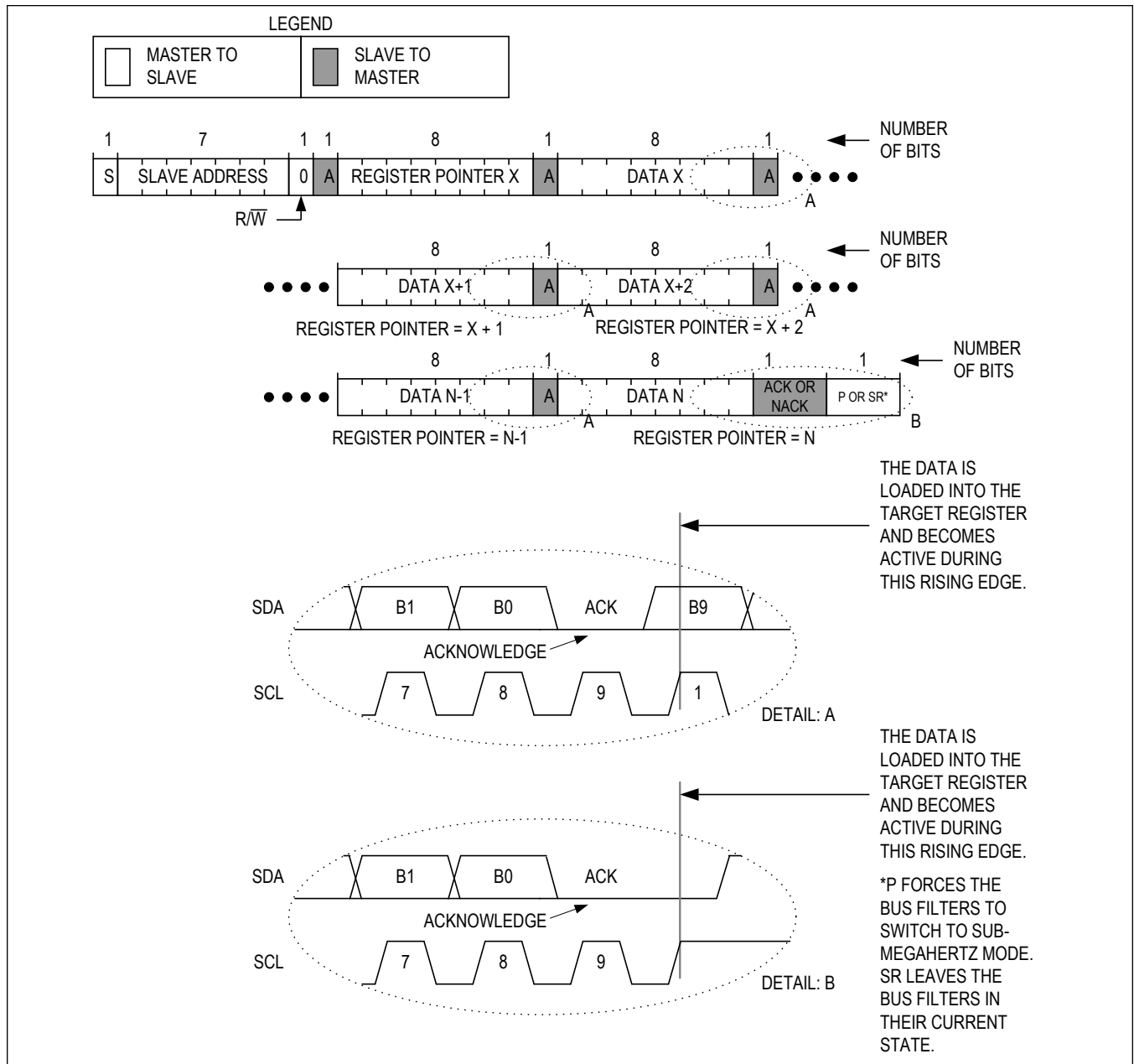

Figure 33. Writing to Sequential Registers X to N

Reading from a Single Register

Figure 34 shows the protocol for the I²C master device to read one byte of data. This protocol is the same as the SMBus specification’s read byte protocol.

The read byte protocol is as follows:

1. The master sends a start command (S).
2. The master sends the 7-bit slave address followed by a write bit (R/W = 0).
3. The addressed slave asserts an acknowledge (A) by pulling SDA low.
4. The master sends an 8-bit register pointer.
5. The slave acknowledges the register pointer.
6. The master sends a repeated start command (Sr).
7. The master sends the 7-bit slave address followed by a read bit (R/W = 1).
8. The addressed slave asserts an acknowledge by pulling SDA low.
9. The addressed slave places 8-bits of data on the bus from the location specified by the register pointer.
10. The master issues a not acknowledge (nA).
11. The master sends a stop condition (P) or a repeated start condition (Sr). Issuing a P ensures that the bus input filters are set for 1MHz or slower operation. Issuing an Sr leaves the bus input filters in their current state.

Note that when this device receives a stop, the register pointer is not modified. Therefore, if the master re-reads the same register, it can immediately send another read command, omitting the command to send a register pointer.

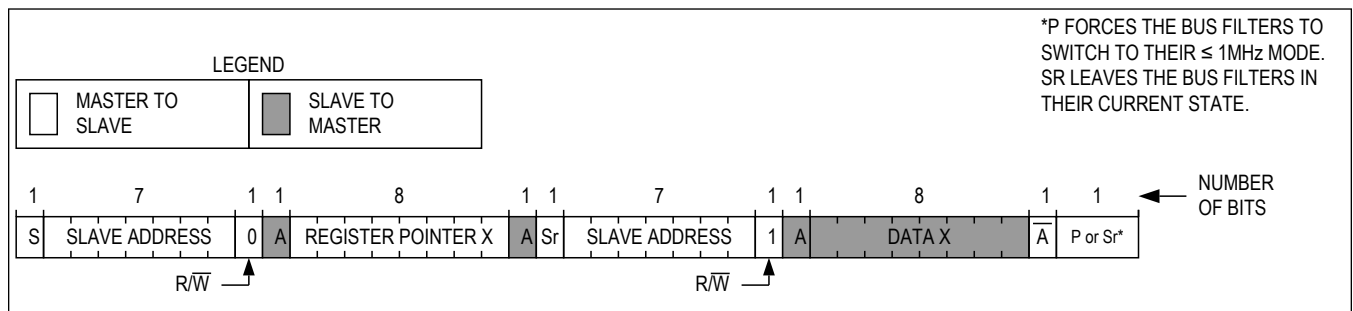

Figure 34. Reading from a Single Register with the Read Byte Protocol

Reading from Sequential Registers

Figure 35 shows the protocol for reading from sequential registers. This protocol is similar to the read byte protocol except the master issues an acknowledge to signal the slave that it wants more data: when the master has all the data it requires it issues a not acknowledge (nA) and a stop (P) to end the transmission. The continuous read from sequential registers protocol is as follows:

1. The master sends a start command (S).
2. The master sends the 7-bit slave address followed by a write bit (R/W = 0).
3. The addressed slave asserts an acknowledge (A) by pulling SDA low.
4. The master sends an 8-bit register pointer.
5. The slave acknowledges the register pointer.
6. The master sends a repeated start command (Sr).
7. The master sends the 7-bit slave address followed by a read bit (R/W = 1).
8. The addressed slave asserts an acknowledge by pulling SDA low.
9. The addressed slave places 8-bits of data on the bus from the location specified by the register pointer.
10. The master issues an acknowledge (A) signaling the slave that it wishes to receive more data.
11. Steps 9 to 10 are repeated as many times as the master requires. Following the last byte of data, the master must issue a not acknowledge (nA) to signal that it wishes to stop receiving data.
12. The master sends a stop condition (P) or a repeated start condition (Sr). Issuing a stop (P) ensures that the bus input filters are set for 1MHz or slower operation. Issuing an Sr leaves the bus input filters in their current state.

Note that when this device receives a stop it does not modify its register pointer. Therefore, if the master re-reads the same register, it can immediately send another read command, omitting the command to send a register pointer.

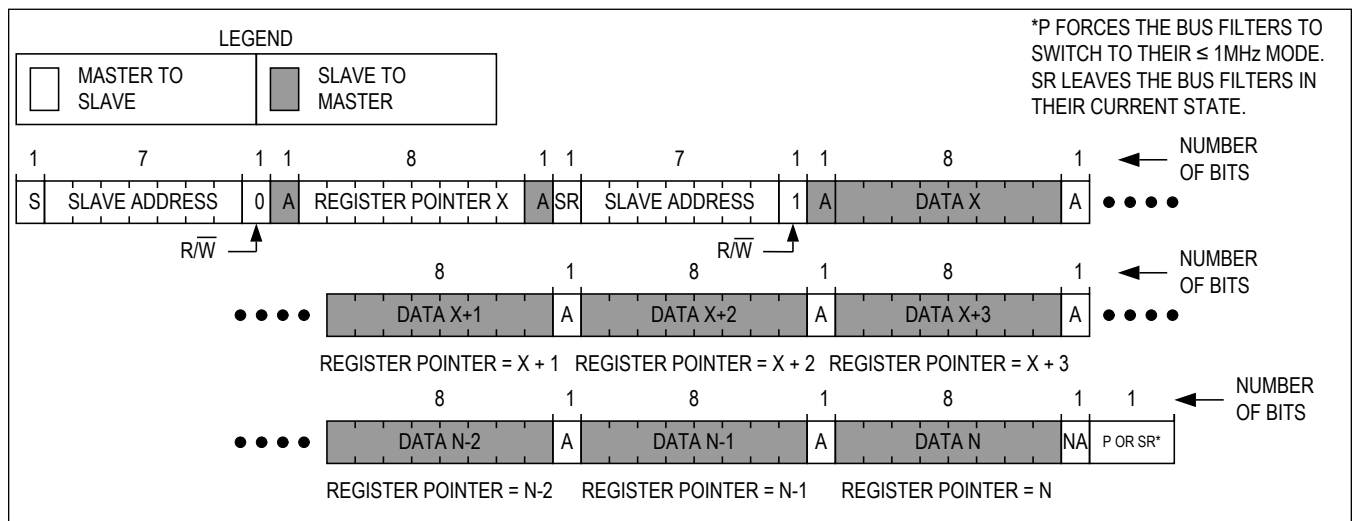

Figure 35. Reading Continuously from Sequential Registers X to N

Engaging HS-Mode for Operation up to 3.4MHz

Figure 36 shows the protocol for engaging HS-mode operation. HS-mode operation allows for a bus operating speed up to 3.4MHz. The engaging HS-mode protocol is as follows:

1. Begin the protocol while operating at a bus speed of 1MHz or lower.
2. The master sends a start command (S).
3. The master sends the 8-bit master code of 0b0000 1XXX where 0bXXX are don't care bits.
4. The addressed slave issues a not acknowledge (nA).
5. The master may now increase its bus speed up to 3.4MHz and issue any read/write operation.

The master may continue to issue high-speed read/write operations until a stop (P) is issued. To continue operations in high-speed mode, use repeated start (Sr)

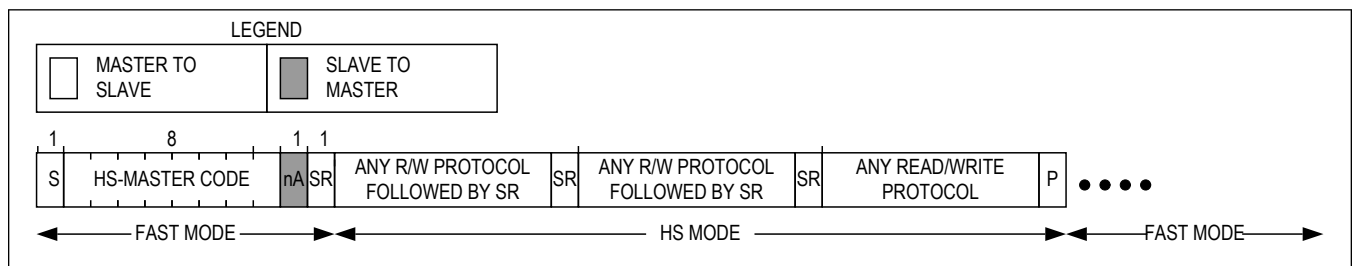

Figure 36. Engaging HS Mode

Register Map

MAX77654

ADDRESS	NAME	MSB							LSB
Global									
0x00	INT_GLBL0[7:0]	DOD0_R	DOD1_R	TJAL2_R	TJAL1_R	nEN_R	nEN_F	GPI0_R	GPI0_F
0x04	INT_GLBL1[7:0]	RSVD	LDO1_F	LDO0_F	SBB_TO	GPI2_R	GPI2_F	GPI1_R	GPI1_F
0x05	ERCFLAG[7:0]	WDT_RST	WDT_OFF	SFT_CRST_F	SFT_OFF_F	MRST	SYSUVL_O	SYSOVL_O	TOVLD
0x06	STAT_GLBL[7:0]	DIDM	BOK	DOD0_S	DOD1_S	TJAL2_S	TJAL1_S	STAT_EN	STAT_IRQ
0x08	INTM_GLBL1[7:0]	RSVD	LDO1_M	LDO0_M	SBB_TO_M	GPI2_RM	GPI2_FM	GPI1_RM	GPI1_FM
0x09	INTM_GLBL0[7:0]	DOD0_RM	DOD1_RM	TJAL2_RM	TJAL1_RM	nEN_RM	nEN_FM	GPI0_RM	GPI0_FM
0x10	CNFG_GLBL[7:0]	PU_DIS	T_MRST	SBIA_LPM	SBIA_EN	nEN_MODE	DBEN_nEN	SFT_CTRL[1:0]	
0x11	CNFG_GPIO0[7:0]	RSVD	–	ALT_GPIO0	DBEN_GPI	DO	DRV	DI	DIR
0x12	CNFG_GPIO1[7:0]	RSVD[1:0]		ALT_GPIO1	DBEN_GPI	DO	DRV	DI	DIR
0x13	CNFG_GPIO2[7:0]	RSVD[1:0]		ALT_GPIO2	DBEN_GPI	DO	DRV	DI	DIR
0x14	CID[7:0]	CID	–	–	–	CID[3:0]			
0x17	CNFG_WDT[7:0]	RSVD[1:0]		WDT_PER[1:0]		WDT_MODE	WDT_CLR	WDT_EN	WDT_LOCK
OVERLAP									
Charger									
0x01	INT_CHG[7:0]	RSVD	SYS_CFG_I	SYS_CTL_I	CHGIN_CTRL_I	TJ_REG_I	CHGIN_I	CHG_I	THM_I
0x02	STAT_CHG_A[7:0]	RSVD	VCHGIN_MIN_STAT	ICHGIN_LIM_STAT	VSYS_MIN_STAT	TJ_REG_STAT	THM_DTLS[2:0]		
0x03	STAT_CHG_B[7:0]	CHG_DTLS[3:0]				CHGIN_DTLS[1:0]		CHG	TIME_SUS
0x07	INT_M_CHG[7:0]	RSVD	SYS_CFG_M	SYS_CTL_M	CHGIN_CTRL_M	TJ_REG_M	CHGIN_M	CHG_M	THM_M
0x20	CNFG_CHG_A[7:0]	THM_HOT[1:0]		THM_WARM[1:0]		THM_COOL[1:0]		THM_COLD[1:0]	
0x21	CNFG_CHG_B[7:0]	VCHGIN_MIN[2:0]			ICHGIN_LIM[2:0]			I_PQ	CHG_EN
0x22	CNFG_CHG_C[7:0]	CHG_PQ[2:0]			I_TERM[1:0]		T_TOPOFF[2:0]		
0x23	CNFG_CHG_D[7:0]	TJ_REG[2:0]			VSYS_REG[4:0]				
0x24	CNFG_CHG_E[7:0]	CHG_CC[5:0]						T_FAST_CHG[1:0]	
0x25	CNFG_CHG_F[7:0]	CHG_CC_JEITA[5:0]						THM_EN	–
0x26	CNFG_CHG_G[7:0]	CHG_CV[5:0]						USBS	RSVD
0x27	CNFG_CHG_H[7:0]	CHG_CV_JEITA[5:0]						RSVD[1:0]	
0x28	CNFG_CHG_I[7:0]	IMON_DISCHG_SCALE[3:0]				MUX_SEL[3:0]			

ADDRESS	NAME	MSB						LSB
SBB								
0x29	CNFG_SBB0_A[7:0]	–	TV_SBB0[6:0]					
0x2A	CNFG_SBB0_B[7:0]	RSVD	OP_MODE	IP_SBB0[1:0]	ADE_SBB0	EN_SBB0[2:0]		
0x2B	CNFG_SBB1_A[7:0]	–	TV_SBB1[6:0]					
0x2C	CNFG_SBB1_B[7:0]	RSVD	OP_MODE	IP_SBB1[1:0]	ADE_SBB1	EN_SBB1[2:0]		
0x2D	CNFG_SBB2_A[7:0]	–	TV_SBB2[6:0]					
0x2E	CNFG_SBB2_B[7:0]	RSVD	OP_MODE	IP_SBB2[1:0]	ADE_SBB2	EN_SBB2[2:0]		
0x2F	CNFG_SBB_TOP[7:0]	ICHGIN_LIM_DE F	–	–	–	–	–	DRV_SBB[1:0]
LDO								
0x38	CNFG_LDO0_A[7:0]	RSVD	TV_LDO0[6:0]					
0x39	CNFG_LDO0_B[7:0]	–	–	–	LDO0_M D	ADE_LD00	EN_LDO0[2:0]	
0x3A	CNFG_LDO1_A[7:0]	RSVD	TV_LDO1[6:0]					
0x3B	CNFG_LDO1_B[7:0]	–	–	–	LDO1_M D	ADE_LD01	EN_LDO1[2:0]	

Register Details

[INT_GLBL0 \(0x00\)](#)

BIT	7	6	5	4	3	2	1	0
Field	DOD0_R	DOD1_R	TJAL2_R	TJAL1_R	nEN_R	nEN_F	GPIO_R	GPIO_F
Reset	0b0	0b0	0b0	0b0	0b0	0b0	0b0	0b0
Access Type	Read Clears All	Read Clears All	Read Clears All	Read Clears All	Read Clears All	Read Clears All	Read Clears All	Read Clears All

BITFIELD	BITS	DESCRIPTION	DECODE
DOD0_R	7	LDO Dropout Detector Rising Interrupt	0 = The LDO has not detected dropout since the last time this bit was read. 1 = The LDO has detected dropout since the last time this bit was read.
DOD1_R	6	LDO Dropout Detector Rising Interrupt	0 = The LDO has not detected dropout since the last time this bit was read. 1 = The LDO has detected dropout since the last time this bit was read.
TJAL2_R	5	Thermal Alarm 2 Rising Interrupt	0 = The junction temperature has not risen above TJAL2 since the last time this bit was read. 1 = The junction temperature has risen above TJAL2 since the last time this bit was read.
TJAL1_R	4	Thermal Alarm 1 Rising Interrupt	0 = The junction temperature has not risen above TJAL1 since the last time this bit was read. 1 = The junction temperature has risen above TJAL1 since the last time this bit was read.

BITFIELD	BITS	DESCRIPTION	DECODE
nEN_R	3	nEN Rising Interrupt	0 = No nEN rising edges have occurred since the last time this bit was read. 1 = A nEN rising edge has occurred since the last time this bit was read.
nEN_F	2	nEN Falling Interrupt	0 = No nEN falling edges have occurred since the last time this bit was read. 1 = A nEN falling edge occurred since the last time this bit was read.
GPI0_R	1	GPI Rising Interrupt Note that "GPI" refers to the GPIO programmed to be an input.	0 = No GPI rising edges have occurred since the last time this bit was read. 1 = A GPI rising edge has occurred since the last time this bit was read.
GPI0_F	0	GPI Falling Interrupt Note that the GPI is the GPIO programmed to be an input.	0 = No GPI falling edges have occurred since the last time this bit was read. 1 = A GPI falling edge has occurred since the last time this bit was read.

INT_GLBL1 (0x04)

BIT	7	6	5	4	3	2	1	0
Field	RSVD	LDO1_F	LDO0_F	SBB_TO	GPI2_R	GPI2_F	GPI1_R	GPI1_F
Reset	0b000	0b0	0b0	0b0	0b0	0b0	0b0	0b0
Access Type	Read Clears All	Read Clears All	Read Clears All	Read Clears All	Read Clears All	Read Clears All	Read Clears All	Read Clears All

BITFIELD	BITS	DESCRIPTION	DECODE
RSVD	7	Reserved. Unutilized bit. Write to 0. Reads are don't care.	
LDO1_F	6	LDO1 Fault Interrupt	0 = No fault has occurred on LDO1 since the last time this bit was read. 1 = LDO1 has fallen out of regulation since the last time this bit was read.
LDO0_F	5	LDO0 Fault Interrupt	0 = No fault has occurred on LDO0 since the last time this bit was read. 1 = LDO0 has fallen out of regulation since the last time this bit was read.
SBB_TO	4	SBB Timeout	0 = NO SBB timeout occurred since the last time this bit was read. 1 = SBB timeout occurred since the last time this bit was read.
GPI2_R	3	GPI Rising Interrupt Note that "GPI" refers to the GPIO programmed to be an input.	0 = No GPI rising edges have occurred since the last time this bit was read. 1 = A GPI rising edge has occurred since the last time this bit was read.
GPI2_F	2	GPI Falling Interrupt Note that the GPI is the GPIO programmed to be an input.	0 = No GPI falling edges have occurred since the last time this bit was read. 1 = A GPI falling edge has occurred since the last time this bit was read.
GPI1_R	1	GPI Rising Interrupt Note that "GPI" refers to the GPIO programmed to be an input.	0 = No GPI rising edges have occurred since the last time this bit was read. 1 = A GPI rising edge has occurred since the last time this bit was read.

BITFIELD	BITS	DESCRIPTION	DECODE
GPI1_F	0	GPI Falling Interrupt Note that the GPI is the GPIO programmed to be an input.	0 = No GPI falling edges have occurred since the last time this bit was read. 1 = A GPI falling edge has occurred since the last time this bit was read.

ERCFLAG (0x05)

BIT	7	6	5	4	3	2	1	0
Field	WDT_RST	WDT_OFF	SFT_CRST_F	SFT_OFF_F	MRST	SYSUVLO	SYSOVLO	TOVLD
Reset	0b0	0b0	0b0	0b0	0b0	0b0	0b0	0b0
Access Type	Read Clears All	Read Clears All	Read Clears All	Read Clears All	Read Clears All	Read Clears All	Read Clears All	Read Clears All

BITFIELD	BITS	DESCRIPTION	DECODE
WDT_RST	7	Watchdog Timer Reset Flag. This bit sets when the watchdog timer expires and causes a power-reset (WDT_MODE = 1).	0 = Watchdog timer has not caused a power-reset since the last time this bit was read. 1 = Watchdog timer has expired and caused a power-reset since the last time this bit was read.
WDT_OFF	6	Watchdog Timer OFF Flag. This bit sets when the watchdog timer expires and causes a power-off (WDT_MODE = 0).	0 = Watchdog timer has not caused a power-off since the last time this bit was read. 1 = Watchdog timer has expired and caused a power-off since the last time this bit was read.
SFT_CRST_F	5	Software Cold Reset Flag	0 = The software cold reset has not occurred since the last read of this register. 1 = The software cold reset has occurred since the last read of this register. This indicates that software has set SFT_CTRL[1:0] = 0b01.
SFT_OFF_F	4	Software OFF Flag	0 = The SFT_OFF function has not occurred since the last read of this register. 1 = The SFT_OFF function has occurred since the last read of this register. This indicates that software has set SFT_CTRL[1:0] = 0b10.
MRST	3	Manual Reset Timer	0 = A manual reset has not occurred since the last read of this register. 1 = A manual reset has occurred since the last read of this register.
SYSUVLO	2	SYS Domain Undervoltage Lockout	0 = The SYS domain undervoltage lockout has not occurred since the last read of this register. 1 = The SYS domain undervoltage lockout has occurred since the last read of this register. This indicates that the SYS domain voltage fell below V _{SYSUVLO} (~2.4V)
SYSOVLO	1	SYS Domain Overvoltage Lockout	0 = The SYS domain overvoltage lockout has not occurred since the last read of this register. 1 = The SYS domain overvoltage lockout has occurred since the last read of this register. This indicates that the SYS domain voltage rose below V _{SYSOVLO} (~5.85V)

BITFIELD	BITS	DESCRIPTION	DECODE
TOVLD	0	Thermal Overload	0 = Thermal overload has not occurred since the last read of this register. 1 = Thermal overload has occurred since the last read of this register. This indicates that the junction temperature has exceeded 165°C.

STAT_GLBL (0x06)

BIT	7	6	5	4	3	2	1	0
Field	DIDM	BOK	DOD0_S	DOD1_S	TJAL2_S	TJAL1_S	STAT_EN	STAT_IRQ
Reset	OTP	0b1	0b0	0b0	0b0	0b0	0b0	0b0
Access Type	Read Only	Read Only	Read Only	Read Only	Read Only	Read Only	Read Only	Read Only

BITFIELD	BITS	DESCRIPTION	DECODE
DIDM	7	Device Identification Bits for Metal Options	0 = MAX77654 1 = Reserved
BOK	6	BOK Interrupt Status	0 = Main bias is not ready. 1 = Main bias enabled and ready.
DOD0_S	5	LDO0 Dropout Detector Rising Status	0 = LDO0 is not in dropout. 1 = LDO0 is in dropout.
DOD1_S	4	LDO1 Dropout Detector Rising Status	0 = LDO1 is not in dropout. 1 = LDO1 is in dropout.
TJAL2_S	3	Thermal Alarm 2 Status	0 = The junction temperature is less than TJA2. 1 = The junction temperature is greater than TJAL2.
TJAL1_S	2	Thermal Alarm 1 Status	0 = The junction temperature is less than TJAL1. 1 = The junction temperature is greater than TJAL1.
STAT_EN	1	Debounced Status for the nEN Input	0 = nEN is not active (logic high). 1 = nEN is active (logic low).
STAT_IRQ	0	Software Version of the nIRQ MOSFET Gate Drive	0 = Unmasked gate drive is logic low. 1 = Unmasked gate drive is logic high.

INTM_GLBL1 (0x08)

BIT	7	6	5	4	3	2	1	0
Field	RSVD	LDO1_M	LDO0_M	SBB_TO_M	GPI2_RM	GPI2_FM	GPI1_RM	GPI1_FM
Reset	0b0	0b1	0b1	0b1	0b1	0b1	0b1	0b1
Access Type	Write, Read	Write, Read	Write, Read	Write, Read	Write, Read	Write, Read	Write, Read	Write, Read

BITFIELD	BITS	DESCRIPTION	DECODE
RSVD	7	Reserved. Unutilized bit. Write to 0. Reads are don't care.	
LDO1_M	6	LDO1 Fault Interrupt Mask	0 = Unmasked. If LDO1_F goes from 0 to 1, then nIRQ goes low. nIRQ goes high when all interrupt bits are cleared. 1 = Masked. nIRQ does not go low due to LDO1_F.

BITFIELD	BITS	DESCRIPTION	DECODE
LDO0_M	5	LDO0 Fault Interrupt Mask	0 = Unmasked. If LDO0_F goes from 0 to 1, then nIRQ goes low. nIRQ goes high when all interrupt bits are cleared. 1 = Masked. nIRQ does not go low due to LDO0_F.
SBB_TO_M	4	SBB Timeout Mask	0 = Unmasked. If SBB_TO goes from 0 to 1, then nIRQ goes low. nIRQ goes high when all interrupt bits are cleared. 1 = Masked. nIRQ does not go low due to SBB_TO.
GPI2_RM	3	GPI Rising Interrupt Mask	0 = Unmasked. If GPI_R goes from 0 to 1, then nIRQ goes low. nIRQ goes high when all interrupt bits are cleared. 1 = Masked. nIRQ does not go low due to GPI_R.
GPI2_FM	2	GPI Falling Interrupt Mask	0 = Unmasked. If GPI_F goes from 0 to 1, then nIRQ goes low. nIRQ goes high when all interrupt bits are cleared. 1 = Masked. nIRQ does not go low due to GPI_F.
GPI1_RM	1	GPI Rising Interrupt Mask	0 = Unmasked. If GPI_R goes from 0 to 1, then nIRQ goes low. nIRQ goes high when all interrupt bits are cleared. 1 = Masked. nIRQ does not go low due to GPI_R.
GPI1_FM	0	GPI Falling Interrupt Mask	0 = Unmasked. If GPI_F goes from 0 to 1, then nIRQ goes low. nIRQ goes high when all interrupt bits are cleared. 1 = Masked. nIRQ does not go low due to GPI_F.

INTM_GLBL0 (0x09)

BIT	7	6	5	4	3	2	1	0
Field	DOD0_RM	DOD1_RM	TJAL2_RM	TJAL1_RM	nEN_RM	nEN_FM	GPI0_RM	GPI0_FM
Reset	0b1	0b1	0b1	0b1	0b1	0b1	0b1	0b1
Access Type	Write, Read	Write, Read	Write, Read	Write, Read	Write, Read	Write, Read	Write, Read	Write, Read

BITFIELD	BITS	DESCRIPTION	DECODE
DOD0_RM	7	LDO Dropout Detector Rising Interrupt Mask	0 = Unmasked. If DOD0_R goes from 0 to 1, then nIRQ goes low. nIRQ goes high when all interrupt bits are cleared. 1 = Masked. nIRQ does not go low due to DOD0_R.
DOD1_RM	6	LDO Dropout Detector Rising Interrupt Mask	0 = Unmasked. If DOD1_R goes from 0 to 1, then nIRQ goes low. nIRQ goes high when all interrupt bits are cleared. 1 = Masked. nIRQ does not go low due to DOD1_R.
TJAL2_RM	5	Thermal Alarm 2 Rising Interrupt Mask	0 = Unmasked. If TJAL2_R goes from 0 to 1, then nIRQ goes low. nIRQ goes high when all interrupt bits are cleared. 1 = Masked. nIRQ does not go low due to TJAL2_R.

BITFIELD	BITS	DESCRIPTION	DECODE
TJAL1_RM	4	Thermal Alarm 1 Rising Interrupt Mask	0 = Unmasked. If TJAL1_R goes from 0 to 1, then nIRQ goes low. nIRQ goes high when all interrupt bits are cleared. 1 = Masked. nIRQ does not go low due to TJAL1_R.
nEN_RM	3	nEN Rising Interrupt Mask	0 = Unmasked. If nEN_R goes from 0 to 1, then nIRQ goes low. nIRQ goes high when all interrupt bits are cleared. 1 = Masked. nIRQ does not go low due to nEN_R.
nEN_FM	2	nEN Falling Interrupt Mask	0 = Unmasked. If nEN_F goes from 0 to 1, then nIRQ goes low. nIRQ goes high when all interrupt bits are cleared. 1 = Masked. nIRQ does not go low due to nEN_F.
GPI0_RM	1	GPI Rising Interrupt Mask	0 = Unmasked. If GPI_R goes from 0 to 1, then nIRQ goes low. nIRQ goes high when all interrupt bits are cleared. 1 = Masked. nIRQ does not go low due to GPI_R.
GPI0_FM	0	GPI Falling Interrupt Mask	0 = Unmasked. If GPI_F goes from 0 to 1, then nIRQ goes low. nIRQ goes high when all interrupt bits are cleared. 1 = Masked. nIRQ does not go low due to GPI_F.

CNFG_GLBL (0x10)

BIT	7	6	5	4	3	2	1	0
Field	PU_DIS	T_MRST	SBIA_LPM	SBIA_EN	nEN_MODE	DBEN_nEN	SFT_CTRL[1:0]	
Reset	0b0	OTP	OTP	0b0	OTP	OTP	0b00	
Access Type	Write, Read	Write, Read	Write, Read	Write, Read	Write, Read	Write, Read	Write, Read	

BITFIELD	BITS	DESCRIPTION	DECODE
PU_DIS	7	nEN Internal Pullup Resistor	0 = Strong internal nEN pullup (200kΩ) 1 = Weak internal nEN pullup (10MΩ)
T_MRST	6	Sets the Manual Reset Time (t _{MRST})	0 = 8s 1 = 16s
SBIA_LPM	5	Main Bias Low-Power Mode Software Request	0 = Main bias requested to be in normal-power mode by software. 1 = Main bias request to be in low-power mode by software.
SBIA_EN	4	Main Bias Enable Software Request	0 = Main bias not enabled by software. Note that the main bias can be enabled by the on/off controller. 1 = Main bias force enabled by software.
nEN_MODE	3	nEN Input (ON-KEY) Default Configuration Mode	0 = Push-button mode 1 = Slide-switch mode
DBEN_nEN	2	Debounce Timer Enable for the nEN Pin	0 = 500μs Debounce 1 = 30ms Debounce

BITFIELD	BITS	DESCRIPTION	DECODE
SFT_CTRL	1:0	<p>Software Reset Functions</p> <p>Note that the SFT_CRST and SFT_OFF commands initiate the power-down sequence flow as described in the data sheet. This power-down sequence flow has delay elements that add up to 205.24ms (60ms delay + 10.24ms nRST assert delay + 4x2.56ms power-down slot delays + 125ms output discharge delay). If issuing the SFT_CRST and/or SFT_OFF functions in software, wait for more than 300ms before trying to issue any additional commands through I²C.</p>	<p>0b00 = No action</p> <p>0b01 = Software cold reset (SFT_CRST). The device powers down, resets, and then powers up again.</p> <p>0b10 = Software off (SFT_OFF). The device powers down, resets, and then the FPS remains off and waiting for a wake-up event.</p> <p>0b11 = Factory-ship mode enter (FSM). The IC powers down, configuration registers reset, and the internal BATT to SYS switch opens. The device remains this way until a factory-ship mode exit event occurs.</p>

CNFG_GPIO0 (0x11)

BIT	7	6	5	4	3	2	1	0
Field	RSVD	–	ALT_GPIO0	DBEN_GPI	DO	DRV	DI	DIR
Reset	0b0	–	OTP	0b0	0b0	0b0	0b0	0b1
Access Type	Write, Read	–	Write, Read	Write, Read	Write, Read	Write, Read	Read Only	Write, Read

BITFIELD	BITS	DESCRIPTION	DECODE
RSVD	7	Reserved. Unutilized bit. Write to 0. Reads are don't care.	
ALT_GPIO0	5	Alternate Mode Enable for GPIO0	0 = Standard GPIO. 1 = Flexible power sequencer active-high output for SBB2.
DBEN_GPI	4	General Purpose Input Debounce Timer Enable	0 = No debounce 1 = 30ms Debounce
DO	3	General Purpose Output Data Output	This bit is a don't care when DIR = 1 (configured as input). When set for GPO (DIR = 0): 0 = GPIO is output logic low. 1 = GPIO is output logic high when set as push-pull output (DRV = 1). GPIO is high-impedance when set as an open-drain output (DRV = 0).
DRV	2	General Purpose Output Driver Type	This bit is a don't care when DIR = 1 (configured as input). When set for GPO (DIR = 0): 0 = Open-drain 1 = Push-pull
DI	1	GPIO Digital Input Value. Irrespective of whether the GPIO is set for GPI (DIR = 1) or GPO (DIR = 0), DI reflects the state of the GPIO.	0 = Input logic low 1 = Input logic high
DIR	0	GPIO Direction	0 = General purpose output (GPO) 1 = General purpose input (GPI)

[CNFG_GPIO1 \(0x12\)](#)

BIT	7	6	5	4	3	2	1	0
Field	RSVD[1:0]		ALT_GPIO1	DBEN_GPI	DO	DRV	DI	DIR
Reset	0b00		OTP	0b0	0b0	0b0	0b0	0b1
Access Type	Write, Read		Write, Read	Write, Read	Write, Read	Write, Read	Read Only	Write, Read

BITFIELD	BITS	DESCRIPTION	DECODE
RSVD	7:6	Reserved. Unutilized bit. Write to 0. Reads are don't care.	
ALT_GPIO1	5	Alternate Mode Enable for GPIO1	0 = Standard GPIO 1 = SBB2 Enable
DBEN_GPI	4	General Purpose Input Debounce Timer Enable	0 = No debounce 1 = 30ms Debounce
DO	3	General Purpose Output Data Output	This bit is a don't care when DIR = 1 (configured as input). When set for GPO (DIR = 0): 0 = GPIO is output logic low. 1 = GPIO is output logic high when set as push-pull output (DRV = 1). GPIO is high-impedance when set as an open-drain output (DRV = 0).
DRV	2	General Purpose Output Driver Type	This bit is a don't care when DIR = 1 (configured as input). When set for GPO (DIR = 0): 0 = Open-drain 1 = Push-pull
DI	1	GPIO Digital Input Value. Irrespective of whether the GPIO is set for GPI (DIR = 1) or GPO (DIR = 0), DI reflects the state of the GPIO.	0 = Input logic low 1 = Input logic high
DIR	0	GPIO Direction	0 = General purpose output (GPO) 1 = General purpose input (GPI)

[CNFG_GPIO2 \(0x13\)](#)

BIT	7	6	5	4	3	2	1	0
Field	RSVD[1:0]		ALT_GPIO2	DBEN_GPI	DO	DRV	DI	DIR
Reset	0b00		OTP	0b0	0b0	0b0	0b0	0b1
Access Type	Write, Read		Write, Read	Write, Read	Write, Read	Write, Read	Read Only	Write, Read

BITFIELD	BITS	DESCRIPTION	DECODE
RSVD	7:6	Reserved. Unutilized bit. Write to 0. Reads are don't care.	
ALT_GPIO2	5	Alternate Mode Enable for GPIO2.	0 = Standard GPIO 1 = Bias LPM mode enable
DBEN_GPI	4	General Purpose Input Debounce Timer Enable	0 = No debounce 1 = 30ms Debounce

BITFIELD	BITS	DESCRIPTION	DECODE
DO	3	General Purpose Output Data Output	This bit is a don't care when DIR = 1 (configured as input). When set for GPO (DIR = 0): 0 = GPIO is output logic low. 1 = GPIO is output logic high when set as push-pull output (DRV = 1). GPIO is high-impedance when set as an open-drain output (DRV = 0).
DRV	2	General Purpose Output Driver Type	This bit is a don't care when DIR = 1 (configured as input). When set for GPO (DIR = 0): 0 = Open-drain 1 = Push-pull
DI	1	GPIO Digital Input Value. Irrespective of whether the GPIO is set for GPI (DIR = 1) or GPO (DIR = 0), DI reflects the state of the GPIO.	0 = Input logic low 1 = Input logic high
DIR	0	GPIO Direction	0 = General purpose output (GPO) 1 = General purpose input (GPI)

CID (0x14)

BIT	7	6	5	4	3	2	1	0
Field	CID	–	–	–	CID[3:0]			
Reset	OTP	–	–	–	OTP			
Access Type	Read Only	–	–	–	Read Only			

BITFIELD	BITS	DESCRIPTION
CID	7	Bit 4 of the Chip Identification Code The chip identification code refers to a set of reset values in the register map, or the "OTP configuration."
CID	3:0	Bits 0 to 3 of the Chip Identification Code The chip identification code refers to a set of reset values in the register map, or the "OTP configuration."

CNFG_WDT (0x17)

BIT	7	6	5	4	3	2	1	0
Field	RSVD[1:0]		WDT_PER[1:0]		WDT_MOD E	WDT_CLR	WDT_EN	WDT_LOC K
Reset	0b00		0b11		0b0	0b0	OTP	OTP
Access Type	Write, Read		Write, Read		Write, Read	Write, Read	Write, Read	Read Only

BITFIELD	BITS	DESCRIPTION	DECODE
RSVD	7:6	Reserved. Unutilized bit. Write to 0. Reads are don't care.	
WDT_PER	5:4	Watchdog Timer Period. Sets t_{WD} . Watchdog timer is reset to the programmed value as soon as this bitfield is changed.	0b00 = 16 seconds 0b01 = 32 seconds 0b10 = 64 seconds 0b11 = 128 seconds

BITFIELD	BITS	DESCRIPTION	DECODE
WDT_MODE	3	Watchdog Timer Expired Action. Determines what the IC does after the watchdog timer expires.	0 = Watchdog timer expire causes power-off. 1 = Watchdog timer expire causes power-reset.
WDT_CLR	2	Watchdog Timer Clear Control. Set this bit to feed (reset) the watchdog timer.	0 = Watchdog timer period is not reset. 1 = Watchdog timer is reset back to t_{WD} .
WDT_EN	1	Watchdog Timer Enable. Write protected depending on WDT_LOCK.	0 = Watchdog timer is not enabled. 1 = Watchdog timer is enabled. The timer expires if not reset by setting WDT_CLR.
WDT_LOCK	0	Factory-Set Safety Bit for the Watchdog Timer. Determines if the timer can be disabled through WDT_EN or not.	0 = Watchdog timer can be enabled and disabled with WDT_EN. 1 = Watchdog timer can not be disabled with WDT_EN. However, WDT_EN can still be used to enable the watchdog timer.

INT_CHG (0x01)

BIT	7	6	5	4	3	2	1	0
Field	RSVD	SYS_CNFG_I	SYS_CTRL_I	CHGIN_CTL_I	TJ_REG_I	CHGIN_I	CHG_I	THM_I
Reset	0b0	0b0	0b0	0b0	0b0	0b0	0b0	0b0
Access Type	Read Clears All	Read Clears All	Read Clears All	Read Clears All	Read Clears All	Read Clears All	Read Clears All	Read Clears All

BITFIELD	BITS	DESCRIPTION	DECODE
RSVD	7	Reserved. Unutilized bit. Write to 0. Reads are don't care.	
SYS_CNFG_I	6	System Voltage Configuration Error Interrupt	0 = The bit combination in CHG_CV has not been forced to change since the last time this bit was read. 1 = The bit combination in CHG_CV has been forced to change to ensure $V_{SYS-REG} = V_{FAST-CHG} + 200mV$ since the last time this bit was read.
SYS_CTRL_I	5	Minimum System Voltage Regulation-Loop Related Interrupt. This interrupt signals a change in the status bit VSYS_MIN_STAT.	0 = The minimum system voltage regulation loop has not engaged since the last time this bit was read. 1 = The minimum system voltage regulation loop has engaged since the last time this bit was read.
CHGIN_CTL_I	4	CHGIN Control-Loop Related Interrupt. This bit asserts when the input reaches current limit ($I_{CHGIN-LIM}$) or V_{CHGIN} falls below $V_{CHGIN-MIN}$.	0 = Neither the VCHGIN_MIN_STAT nor the ICHGIN_LIM_STAT bits have changed since the last time this bit was read. 1 = The VCHGIN_MIN_STAT or ICHGIN_LIM_STAT bits have changed since the last time this bit was read.
TJ_REG_I	3	Die Junction Temperature Regulation Interrupt. This bit asserts when the die temperature (T_J) exceeds T_{J-REG} . This interrupt signals a change in the status bit TJ_REG_STAT.	0 = The die temperature has not exceeded T_{J-REG} since the last time this bit was read. 1 = The die temperature has exceeded T_{J-REG} since the last time this bit was read.
CHGIN_I	2	CHGIN Related Interrupt	0 = The bits in CHGIN_DTLS[1:0] have not changed since the last time this bit was read. 1 = The bits in CHGIN_DTLS[1:0] have changed since the last time this bit was read.

BITFIELD	BITS	DESCRIPTION	DECODE
CHG_I	1	Charger Related Interrupt	0 = The bits in CHG_DTLS[3:0] have not changed since the last time this bit was read. 1 = The bits in CHG_DTLS[3:0] have changed since the last time this bit was read.
THM_I	0	Thermistor Related Interrupt	0 = The bits in THM_DTLS[2:0] have not changed since the last time this bit was read. 1 = The bits in THM_DTLS[2:0] have changed since the last time this bit was read.

STAT_CHG_A (0x02)

BIT	7	6	5	4	3	2	1	0
Field	RSVD	VCHGIN_MIN_STAT	ICHGIN_LIM_STAT	VSYS_MIN_STAT	TJ_REG_STAT	THM_DTLS[2:0]		
Reset	0b0	0b0	0b0	0b0	0b0	0b000		
Access Type	Read Only	Read Only	Read Only	Read Only	Read Only	Read Only		

BITFIELD	BITS	DESCRIPTION	DECODE
RSVD	7	Reserved. Unutilized bit. Write to 0. Reads are don't care.	
VCHGIN_MIN_STAT	6	Minimum Input Voltage Regulation Loop Status	0 = The minimum CHGIN voltage regulation loop is not engaged. 1 = The minimum CHGIN voltage regulation loop has engaged to regulate $V_{CHGIN} \geq V_{CHGIN-MIN}$.
ICHGIN_LIM_STAT	5	Input Current Limit Loop Status	0 = The CHGIN current limit loop is not engaged. 1 = The CHGIN current limit loop has engaged to regulate $I_{CHGIN} \leq I_{CHGIN-LIM}$.
VSYS_MIN_STAT	4	Minimum System Voltage Regulation Loop Status	0 = The minimum system voltage regulation loop is not engaged. 1 = The minimum system voltage regulation loop is engaged to regulate $V_{SYS} \geq V_{SYS-MIN}$.
TJ_REG_STAT	3	Maximum Junction Temperature Regulation Loop Status	0 = The maximum junction temperature regulation loop is not engaged. 1 = The maximum junction temperature regulation loop has engaged to regulate the junction temperature to less than T_{J-REG} .
THM_DTLS	2:0	Battery Temperature Details. Valid only when CHGIN_DTLS[1:0] = 0b11.	0b000 = Thermistor is disabled (THM_EN = 0). 0b001 = Battery is cold as programmed by THM_COLD[1:0]. If thermistor and charger are enabled while the battery is cold, a battery temperature fault occurs. 0b010 = Battery is cool as programmed by THM_COOL[1:0]. 0b011 = Battery is warm as programmed by THM_WARM[1:0]. 0b100 = Battery is hot as programmed by THM_HOT[1:0]. If thermistor and charger are enabled while the battery is hot, a battery temperature fault occurs. 0b101 = Battery is in the normal temperature region. 0b110 to 0b111 = Reserved.

[STAT_CHG_B \(0x03\)](#)

BIT	7	6	5	4	3	2	1	0
Field	CHG_DTLS[3:0]				CHGIN_DTLS[1:0]		CHG	TIME_SUS
Reset	0x0				0b00		0b0	0b0
Access Type	Read Only				Read Only		Read Only	Read Only

BITFIELD	BITS	DESCRIPTION	DECODE
CHG_DTLS	7:4	Charger Details	0b0000 = Off 0b0001 = Prequalification mode. 0b0010 = Fast-charge constant-current (CC) mode. 0b0011 = JEITA modified fast-charge constant-current mode. 0b0100 = Fast-charge constant-voltage (CV) mode. 0b0101 = JEITA modified fast-charge constant-voltage mode. 0b0110 = Top-off mode. 0b0111 = JEITA modified top-off mode. 0b1000 = Done 0b1001 = JEITA modified done (done was entered through the JEITA-modified fast-charge states). 0b1010 = Prequalification timer fault. 0b1011 = Fast-charge timer fault. 0b1100 = Battery temperature fault. 0b1101 to 0b1111 = Reserved.
CHGIN_DTLS	3:2	CHGIN Status Detail	0b00 = The CHGIN input voltage is below the UVLO threshold ($V_{CHGIN} < V_{UVLO}$). 0b01 = The CHGIN input voltage is above the OVP threshold ($V_{CHGIN} > V_{OVP}$). 0b10 = The CHGIN input is being debounced (no power accepted from CHGIN during debounce). 0b11 = The CHGIN input is okay and debounced.
CHG	1	Quick Charger Status	0 = Charging is not happening. 1 = Charging is happening.
TIME_SUS	0	Time Suspend Indicator	0 = The charger's timers are either not active, or not suspended. 1 = The charger's active timer is suspended due to one of three reasons: charge current dropped below 20% of $I_{FAST-CHG}$ while the charger state machine is in FAST CHARGE CC mode, the charger is in SUPPLEMENT mode, or the charger state machine is in BATTERY TEMPERATURE FAULT mode.

[INT_M_CHG \(0x07\)](#)

BIT	7	6	5	4	3	2	1	0
Field	RSVD	SYS_CNFG_M	SYS_CTRL_M	CHGIN_CTL_M	TJ_REG_M	CHGIN_M	CHG_M	THM_M
Reset	0b1	0b1	0b1	0b1	0b1	0b1	0b1	0b1
Access Type	Write, Read	Write, Read	Write, Read	Write, Read	Write, Read	Write, Read	Write, Read	Write, Read

BITFIELD	BITS	DESCRIPTION	DECODE
RSVD	7	Reserved. Unutilized bit. Write to 0. Reads are don't care.	
SYS_CNFG_M	6	Setting this bit prevents the SYS_CNFG_I bit from causing hardware IRQs.	0 = SYS_CNFG_I is not masked. 1 = SYS_CNFG_I is masked.
SYS_CTRL_M	5	Setting this bit prevents the SYS_CTRL_I bit from causing hardware IRQs.	0 = SYS_CTRL_I is not masked. 1 = SYS_CTRL_I is masked.
CHGIN_CTRL_M	4	Setting this bit prevents the CHGIN_CTRL_I bit from causing hardware IRQs.	0 = CHGIN_CTRL_I is not masked. 1 = CHGIN_CTRL_I is masked.
TJ_REG_M	3	Setting this bit prevents the TJREG_I bit from causing hardware IRQs.	0 = TJREG_I is not masked. 1 = TJREG_I is masked.
CHGIN_M	2	Setting this bit prevents the CHGIN_I bit from causing hardware IRQs.	0 = CHGIN_I is not masked. 1 = CHGIN_I is masked.
CHG_M	1	Setting this bit prevents the CHG_I bit from causing hardware IRQs.	0 = CHG_I is not masked. 1 = CHG_I is masked.
THM_M	0	Setting this bit prevents the THM_I bit from causing hardware IRQs.	0 = THM_I is not masked. 1 = THM_I is masked.

CNFG_CHG_A (0x20)

BIT	7	6	5	4	3	2	1	0
Field	THM_HOT[1:0]		THM_WARM[1:0]		THM_COOL[1:0]		THM_COLD[1:0]	
Reset	0b00		0b00		0b11		0b11	
Access Type	Write, Read		Write, Read		Write, Read		Write, Read	

BITFIELD	BITS	DESCRIPTION	DECODE
THM_HOT	7:6	Sets the V_{HOT} JEITA Temperature Threshold	0b00 = $V_{HOT} = 0.411V$ (45°C for $\beta = 3380K$) 0b01 = $V_{HOT} = 0.367V$ (50°C for $\beta = 3380K$) 0b10 = $V_{HOT} = 0.327V$ (55°C for $\beta = 3380K$) 0b11 = $V_{HOT} = 0.291V$ (60°C for $\beta = 3380K$)
THM_WARM	5:4	Sets the V_{WARM} JEITA Temperature Threshold	0b00 = $V_{WARM} = 0.511V$ (35°C for $\beta = 3380K$) 0b01 = $V_{WARM} = 0.459V$ (40°C for $\beta = 3380K$) 0b10 = $V_{WARM} = 0.411V$ (45°C for $\beta = 3380K$) 0b11 = $V_{WARM} = 0.367V$ (50°C for $\beta = 3380K$)
THM_COOL	3:2	Sets the V_{COOL} JEITA Temperature Threshold	0b00 = $V_{COOL} = 0.923V$ (0°C for $\beta = 3380K$) 0b01 = $V_{COOL} = 0.867V$ (5°C for $\beta = 3380K$) 0b10 = $V_{COOL} = 0.807V$ (10°C for $\beta = 3380K$) 0b11 = $V_{COOL} = 0.747V$ (15°C for $\beta = 3380K$)
THM_COLD	1:0	Sets the V_{COLD} JEITA Temperature Threshold	0b00 = $V_{COLD} = 1.024V$ (-10°C for $\beta = 3380K$) 0b01 = $V_{COLD} = 0.976V$ (-5°C for $\beta = 3380K$) 0b10 = $V_{COLD} = 0.923V$ (0°C for $\beta = 3380K$) 0b11 = $V_{COLD} = 0.867V$ (5°C for $\beta = 3380K$)

CNFG_CHG_B (0x21)

BIT	7	6	5	4	3	2	1	0
Field	VCHGIN_MIN[2:0]			ICHGIN_LIM[2:0]			I_PQ	CHG_EN
Reset	0b000			0b000			0b0	OTP
Access Type	Write, Read			Write, Read			Write, Read	Write, Read

BITFIELD	BITS	DESCRIPTION	DECODE
VCHGIN_MIN	7:5	Minimum CHGIN Regulation Voltage (V _{CHGIN-MIN})	0b000 = 4.0V 0b001 = 4.1V 0b010 = 4.2V 0b011 = 4.3V 0b100 = 4.4V 0b101 = 4.5V 0b110 = 4.6V 0b111 = 4.7V
ICHGIN_LIM	4:2	CHGIN Input Current Limit (I _{CHGIN-LIM})	When CNFG_SBB_TOP.ICHGIN_LIM_DEF = 0: 0b000 = 95mA 0b001 = 190mA 0b010 = 285mA 0b011 = 380mA 0b100 = 475mA 0b101 to 0b111 = Reserved. Defaults to 0b100. When CNFG_SBB_TOP.ICHGIN_LIM_DEF = 1, the above list is reversed.
I_PQ	1	Sets the prequalification charge current (I _{PQ}) as a percentage of I _{FAST-CHG} .	0 = 10% 1 = 20%
CHG_EN	0	Charger Enable	0 = The battery charger is disabled. 1 = The battery charger is enabled.

CNFG_CHG_C (0x22)

BIT	7	6	5	4	3	2	1	0
Field	CHG_PQ[2:0]			I_TERM[1:0]		T_TOPOFF[2:0]		
Reset	0b111			0b11		0b000		
Access Type	Write, Read			Write, Read		Write, Read		

BITFIELD	BITS	DESCRIPTION	DECODE
CHG_PQ	7:5	Battery Prequalification Voltage Threshold (V _{PQ})	0b000 = 2.3V 0b001 = 2.4V 0b010 = 2.5V 0b011 = 2.6V 0b100 = 2.7V 0b101 = 2.8V 0b110 = 2.9V 0b111 = 3.0V
I_TERM	4:3	Charger Termination Current (I _{TERM}). I_TERM[1:0] sets the charger termination current as a percentage of the fast-charge current I _{FAST-CHG} .	00 = 5% 01 = 7.5% 10 = 10% 11 = 15%
T_TOPOFF	2:0	Top-Off Timer Value (t _{TO})	0b000 = 0 minutes 0b001 = 5 minutes 0b010 = 10 minutes 0b011 = 15 minutes 0b100 = 20 minutes 0b101 = 25 minutes 0b110 = 30 minutes 0b111 = 35 minutes

[CNFG_CHG_D \(0x23\)](#)

BIT	7	6	5	4	3	2	1	0
Field	TJ_REG[2:0]				VSYS_REG[4:0]			
Reset	0b000				0b10000			
Access Type	Write, Read				Write, Read			

BITFIELD	BITS	DESCRIPTION	DECODE
TJ_REG	7:5	Sets the die junction temperature regulation point, T_{J-REG} .	0b000 = 60°C 0b001 = 70°C 0b010 = 80°C 0b011 = 90°C 0b100 to 0b111 = 100°C
VSYS_REG	4:0	System Voltage Regulation ($V_{SYS-REG}$) This 5-bit configuration is a linear transfer function that starts at 4.1V and ends at 4.8V, with 25mV increments. Program V_{SYS_REG} to at least 200mV above the higher of $V_{FAST-CHG}$ and $V_{FAST-CHG-JEITA}$.	0x0 = 4.100V 0x1 = 4.125V 0x2 = 4.150V ... 0x1B = 4.775V 0x1C - 0x1F = 4.800V

[CNFG_CHG_E \(0x24\)](#)

BIT	7	6	5	4	3	2	1	0
Field	CHG_CC[5:0]						T_FAST_CHG[1:0]	
Reset	0b000001						0b01	
Access Type	Write, Read						Write, Read	

BITFIELD	BITS	DESCRIPTION	DECODE
CHG_CC	7:2	Sets the fast-charge constant current value, $I_{FAST-CHG}$. This 6-bit configuration is a linear transfer function that starts at 7.5mA and ends at 300mA, with 7.5mA increments.	0x0 = 7.5mA 0x1 = 15.0mA 0x2 = 22.5mA ... 0x26 = 292.5mA 0x27 to 0x3F = 300.0mA
T_FAST_CHG	1:0	Sets the fast-charge safety timer, t_{FC} .	0b00 = Timer disabled 0b01 = 3 hours 0b10 = 5 hours 0b11 = 7 hours

[CNFG_CHG_F \(0x25\)](#)

BIT	7	6	5	4	3	2	1	0
Field	CHG_CC_JEITA[5:0]						THM_EN	-
Reset	0b000001						0b0	-
Access Type	Write, Read						Write, Read	-

BITFIELD	BITS	DESCRIPTION	DECODE
CHG_CC_JEITA	7:2	Sets I _{FAST-CHG-JEITA} for when the battery is either cool or warm as defined by the V _{COOL} and V _{WARM} temperature thresholds. This register is a don't care if the battery temperature is normal. This 6-bit configuration is a linear transfer function that starts at 7.5mA and ends at 300mA, with 7.5mA increments.	0x0 = 7.5mA 0x1 = 15.0mA 0x2 = 22.5mA ... 0x26 = 292.5mA 0x27 to 0x3F = 300.0mA
THM_EN	1	Thermistor Enable Bit	0 = Thermistor is disabled. 1 = Thermistor is enabled. Note that the thermistor is powered by the charger input.

CNFG_CHG_G (0x26)

BIT	7	6	5	4	3	2	1	0
Field	CHG_CV[5:0]						USBS	RSVD
Reset	0b000000						0b0	0b0
Access Type	Write, Read						Write, Read	Write, Read

BITFIELD	BITS	DESCRIPTION	DECODE
CHG_CV	7:2	Sets fast-charge battery regulation voltage, V _{FAST-CHG} . This 6-bit configuration is a linear transfer function that starts at 3.6V and ends at 4.6V, with 25mV increments. Program V _{SYS_REG} to at least 200mV above the higher of V _{FAST-CHG} and V _{FAST-CHG-JEITA} .	0x0 = 3.600V 0x1 = 3.625V 0x2 = 3.650V ... 0x27 = 4.575V 0x28 to 0x3F = 4.600V
USBS	1	Setting this bit places CHGIN in USB suspend mode.	0 = CHGIN is not suspended and may draw current from an adapter source. 1 = CHGIN is suspended and may not draw current from an adapter source. Note: USBS = 1 results in CHGIN_I interrupt AND CHGIN_DTLS[1:0] = 0b00.
RSVD	0	Reserved. Unutilized bit. Write to 0. Reads are don't care.	

CNFG_CHG_H (0x27)

BIT	7	6	5	4	3	2	1	0
Field	CHG_CV_JEITA[5:0]						RSVD[1:0]	
Reset	0b000000						0b00	
Access Type	Write, Read						Write, Read	

BITFIELD	BITS	DESCRIPTION	DECODE
CHG_CV_JEITA	7:2	<p>Sets the modified $V_{FAST-CHG-JEITA}$ for when the battery is either cool or warm as defined by the V_{COOL} and V_{WARM} temperature thresholds. This register is a don't care if the battery temperature is normal.</p> <p>This 6-bit configuration is a linear transfer function that starts at 3.6V and ends at 4.6V, with 25mV increments.</p> <p>Program V_{SYS_REG} to at least 200mV above the higher of $V_{FAST-CHG}$ and $V_{FAST-CHG-JEITA}$.</p>	<p>0x0 = 3.600V 0x1 = 3.625V 0x2 = 3.650V ... 0x27 = 4.575V 0x28 to 0x3F = 4.600V</p>
RSVD	1:0	Reserved. Unutilized bit. Write to 0. Reads are don't care.	

CNFG_CHG_I (0x28)

BIT	7	6	5	4	3	2	1	0
Field	IMON_DISCHG_SCALE[3:0]				MUX_SEL[3:0]			
Reset	0xF				0x0			
Access Type	Write, Read				Write, Read			

BITFIELD	BITS	DESCRIPTION	DECODE
IMON_DISCHG_SCALE	7:4	Selects the battery discharge current full-scale current value.	<p>0x0 = 8.2mA 0x1 = 40.5mA 0x2 = 72.3mA 0x3 = 103.4mA 0x4 = 134.1mA 0x5 = 164.1mA 0x6 = 193.7mA 0x7 = 222.7mA 0x8 = 251.2mA 0x9 = 279.3mA 0xA to 0xF = 300.0mA</p>
MUX_SEL	3:0	<p>Selects the analog channel to connect to AMUX:</p> <p>Note that the multiplexer consumes current unless it is in the 0b0000 state. When measurements are not needed, make sure to configure $MUX_SEL[3:0] = 0b0000$. Also note that for AMUX to operate, the on/off controller must be in the "Resource On" state.</p>	<p>0b0000 = Multiplexer is disabled and AMUX is high-impedance. 0b0001 = CHGIN voltage monitor. 0b0010 = CHGIN current monitor. 0b0011 = BATT voltage monitor. 0b0100 = BATT charge current monitor. Valid only while battery charging is happening (CHG = 1). 0b0101 = BATT discharge current monitor normal measurement. 0b0110 = BATT discharge current monitor nulling measurement. 0b0111 = THM voltage monitor. 0b1000 = TBIAS voltage monitor. 0b1001 = AGND voltage monitor (through 100Ω pulldown resistor). 0b1010 to 0b1111 = SYS voltage monitor.</p>

[CNFG_SBB0_A \(0x29\)](#)

BIT	7	6	5	4	3	2	1	0
Field	–	TV_SBB0[6:0]						
Reset	–	OTP						
Access Type	–	Write, Read						

BITFIELD	BITS	DESCRIPTION	DECODE
TV_SBB0	6:0	SIMO Buck-Boost Channel 0 Target Output Voltage This 7-bit configuration is a linear transfer function that starts at 0.8V, ends at 5.5V, with 50mV increments.	0x00 = 0.800V 0x01 = 0.850V 0x02 = 0.900V 0x03 = 0.950V 0x04 = 1.000V 0x05 = 1.050V 0x06 = 1.100V ... 0x5C = 5.400V 0x5D = 5.450V 0x5E = 5.500V 0x5F to 0x7F = Reserved

[CNFG_SBB0_B \(0x2A\)](#)

BIT	7	6	5	4	3	2	1	0
Field	RSVD	OP_MODE	IP_SBB0[1:0]		ADE_SBB0	EN_SBB0[2:0]		
Reset	0b0	OTP	OTP		OTP	OTP		
Access Type	Write, Read	Write, Read	Write, Read		Write, Read	Write, Read		

BITFIELD	BITS	DESCRIPTION	DECODE
RSVD	7	Reserved. Unutilized bit. Write to 0. Reads are don't care.	
OP_MODE	6	Operation Mode of SBB0	0 = Buck-boost mode 1 = Buck mode
IP_SBB0	5:4	SIMO Buck-Boost Channel 0 Peak Current Limit	0b00 = 1.000A 0b01 = 0.750A 0b10 = 0.500A 0b11 = 0.333A
ADE_SBB0	3	SIMO Buck-Boost Channel 0 Active-Discharge Enable	0 = The active discharge function is disabled. When SBB0 is disabled, its discharge rate is a function of the output capacitance and the external load. 1 = The active discharge function is enabled. When SBB0 is disabled, an internal resistor (R _{AD_SBB0}) is activated from SBB0 to PGND to help the output voltage discharge. The output voltage discharge rate is a function of the output capacitance, the external loading, and the internal R _{AD_SBB0} load.

BITFIELD	BITS	DESCRIPTION	DECODE
EN_SBB0	2:0	Enable Control for SIMO Buck-Boost Channel 0, selecting either an FPS slot the channel powers-up and powers-down in or whether the channel is forced on or off.	0b000 = FPS slot 0 0b001 = FPS slot 1 0b010 = FPS slot 2 0b011 = FPS slot 3 0b100 = Off irrespective of FPS 0b101 = Same as 0b100 0b110 = On irrespective of FPS 0b111 = Same as 0b110

CNFG_SBB1_A (0x2B)

BIT	7	6	5	4	3	2	1	0
Field	–	TV_SBB1[6:0]						
Reset	–	OTP						
Access Type	–	Write, Read						

BITFIELD	BITS	DESCRIPTION	DECODE
TV_SBB1	6:0	SIMO Buck-Boost Channel 1 Target Output Voltage This 7-bit configuration is a linear transfer function that starts at 0.8V, ends at 5.5V, with 50mV increments.	0x00 = 0.800V 0x01 = 0.850V 0x02 = 0.900V 0x03 = 0.950V 0x04 = 1.000V 0x05 = 1.050V 0x06 = 1.100V ... 0x5C = 5.400V 0x5D = 5.450V 0x5E = 5.500V 0x5F to 0x7F = Reserved

CNFG_SBB1_B (0x2C)

BIT	7	6	5	4	3	2	1	0
Field	RSVD	OP_MODE	IP_SBB1[1:0]		ADE_SBB1	EN_SBB1[2:0]		
Reset	0b0	OTP	OTP		OTP	OTP		
Access Type	Write, Read	Write, Read	Write, Read		Write, Read	Write, Read		

BITFIELD	BITS	DESCRIPTION	DECODE
RSVD	7	Reserved. Unutilized bit. Write to 0. Reads are don't care.	
OP_MODE	6	Operation Mode of SBB1	0 = Buck-boost mode 1 = Buck mode
IP_SBB1	5:4	SIMO Buck-Boost Channel 1 Peak Current Limit	0b00 = 1.000A 0b01 = 0.750A 0b10 = 0.500A 0b11 = 0.333A

BITFIELD	BITS	DESCRIPTION	DECODE
ADE_SBB1	3	SIMO Buck-Boost Channel 1 Active-Discharge Enable	0 = The active discharge function is disabled. When SBB1 is disabled, its discharge rate is a function of the output capacitance and the external load. 1 = The active discharge function is enabled. When SBB1 is disabled, an internal resistor (RAD_SBB1) is activated from SBB1 to PGND to help the output voltage discharge. The output voltage discharge rate is a function of the output capacitance, the external loading, and the internal RAD_SBB1 load.
EN_SBB1	2:0	Enable control for SIMO buck-boost channel 1, selecting either an FPS slot the channel powers-up and powers-down in or whether the channel is forced on or off.	0b000 = FPS slot 0 0b001 = FPS slot 1 0b010 = FPS slot 2 0b011 = FPS slot 3 0b100 = Off irrespective of FPS 0b101 = Same as 0b100 0b110 = On irrespective of FPS 0b111 = Same as 0b110

CNFG_SBB2_A (0x2D)

BIT	7	6	5	4	3	2	1	0
Field	–	TV_SBB2[6:0]						
Reset	–	OTP						
Access Type	–	Write, Read						

BITFIELD	BITS	DESCRIPTION	DECODE
TV_SBB2	6:0	SIMO Buck-Boost Channel 2 Target Output Voltage This 7-bit configuration is a linear transfer function that starts at 0.8V, ends at 5.5V, with 50mV increments.	0x00 = 0.800V 0x01 = 0.850V 0x02 = 0.900V 0x03 = 0.950V 0x04 = 1.000V 0x05 = 1.050V 0x06 = 1.100V ... 0x5C = 5.400V 0x5D = 5.450V 0x5E = 5.500V 0x5F to 0x7F = Reserved

CNFG_SBB2_B (0x2E)

BIT	7	6	5	4	3	2	1	0
Field	RSVD	OP_MODE	IP_SBB2[1:0]		ADE_SBB2	EN_SBB2[2:0]		
Reset	0b0	OTP	OTP		OTP	OTP		
Access Type	Write, Read	Write, Read	Write, Read		Write, Read	Write, Read		
BITFIELD	BITS	DESCRIPTION	DECODE					
RSVD	7	Reserved. Unutilized bit. Write to 0. Reads are don't care.						
OP_MODE	6	Operation Mode of SBB2	0 = Buck-boost mode 1 = Buck mode					

BITFIELD	BITS	DESCRIPTION	DECODE
IP_SBB2	5:4	SIMO Buck-Boost Channel 2 Peak Current Limit	0b00 = 1.000A 0b01 = 0.750A 0b10 = 0.500A 0b11 = 0.333A
ADE_SBB2	3	SIMO Buck-Boost Channel 2 Active-Discharge Enable	0 = The active discharge function is disabled. When SBB2 is disabled, its discharge rate is a function of the output capacitance and the external load. 1 = The active discharge function is enabled. When SBB2 is disabled, an internal resistor (RAD_SBB2) is activated from SBB2 to PGND to help the output voltage discharge. The output voltage discharge rate is a function of the output capacitance, the external loading, and the internal RAD_SBB2 load.
EN_SBB2	2:0	Enable control for SIMO buck-boost channel 2, selecting either an FPS slot the channel powers-up and powers-down in or whether the channel is forced on or off.	0b000 = FPS slot 0 0b001 = FPS slot 1 0b010 = FPS slot 2 0b011 = FPS slot 3 0b100 = Off irrespective of FPS 0b101 = Same as 0b100 0b110 = On irrespective of FPS 0b111 = Same as 0b110

CNFG_SBB_TOP (0x2F)

BIT	7	6	5	4	3	2	1	0
Field	ICHGIN_LIM_DEF	–	–	–	–	–	DRV_SBB[1:0]	
Reset	OTP	–	–	–	–	–	0x0	
Access Type	Read Only	–	–	–	–	–	Write, Read	

BITFIELD	BITS	DESCRIPTION	DECODE
ICHGIN_LIM_DEF	7	Changes how CNFG_CHG_B.ICHGIN_LIM is interpreted. This bit is for information only and cannot be changed.	See CNFG_CHG_B.ICHGIN_LIM for more details.
DRV_SBB	1:0	SIMO Buck-Boost (all channels) Drive Strength Trim. See the <i>Drive Strength</i> section for more details.	0b00 = Fastest transition time 0b01 = A little slower than 0b00 0b10 = A little slower than 0b01 0b11 = A little slower than 0b10

CNFG_LDO0_A (0x38)

BIT	7	6	5	4	3	2	1	0
Field	RSVD	TV_LDO0[6:0]						
Reset	0b0	OTP						
Access Type	Write, Read	Write, Read						

BITFIELD	BITS	DESCRIPTION	DECODE
RSVD	7	Reserved. Unutilized bit. Write to 0. Reads are don't care.	

BITFIELD	BITS	DESCRIPTION	DECODE
TV_LDO0	6:0	LDO Target Output Voltage This 7-bit configuration is a linear transfer function that starts at 0.8V and ends at 3.975V, with 25mV increments.	0x00 = 0.800V 0x01 = 0.825V 0x02 = 0.850V 0x03 = 0.875V 0x04 = 0.900V 0x05 = 0.925V 0x06 = 0.950V ... 0x7D = 3.925V 0x7E = 3.950V 0x7F = 3.975V

CNFG_LDO0_B (0x39)

BIT	7	6	5	4	3	2	1	0
Field	–	–	–	LDO0_MD	ADE_LDO0	EN_LDO0[2:0]		
Reset	–	–	–	OTP	OTP	OTP		
Access Type	–	–	–	Write, Read	Write, Read	Write, Read		

BITFIELD	BITS	DESCRIPTION	DECODE
LDO0_MD	4	Operation Mode of LDO0	0 = Low dropout linear regulator (LDO) mode 1 = Load switch (LSW) mode
ADE_LDO0	3	LDO0 Active-Discharge Enable	0 = The active discharge function is disabled. When LDO0 is disabled, its discharge rate is a function of the output capacitance and the external load. 1 = The active discharge function is enabled. When LDO0 is disabled, an internal resistor (RAD_LDO0) is activated from LDO0 to GND to help the output voltage discharge. The output voltage discharge rate is a function of the output capacitance, the external loading, and the internal RAD_LDO0 load.
EN_LDO0	2:0	Enable Control for LDO0, selecting either an FPS slot the channel powers-up and powers-down in or whether the channel is forced on or off.	0b000 = FPS slot 0 0b001 = FPS slot 1 0b010 = FPS slot 2 0b011 = FPS slot 3 0b100 = Off irrespective of FPS 0b101 = Same as 0b100 0b110 = On irrespective of FPS 0b111 = Same as 0b110

CNFG_LDO1_A (0x3A)

BIT	7	6	5	4	3	2	1	0
Field	RSVD	TV_LDO1[6:0]						
Reset	0b0	OTP						
Access Type	Write, Read	Write, Read						

BITFIELD	BITS	DESCRIPTION	DECODE
RSVD	7	Reserved. Unutilized bit. Write to 0. Reads are don't care.	

BITFIELD	BITS	DESCRIPTION	DECODE
TV_LDO1	6:0	LDO Target Output Voltage This 7-bit configuration is a linear transfer function that starts at 0.8V and ends at 3.975V, with 25mV increments.	0x00 = 0.800V 0x01 = 0.825V 0x02 = 0.850V 0x03 = 0.875V 0x04 = 0.900V 0x05 = 0.925V 0x06 = 0.950V ... 0x7D = 3.925V 0x7E = 3.950V 0x7F = 3.975V

CNFG_LDO1_B (0x3B)

BIT	7	6	5	4	3	2	1	0
Field	–	–	–	LDO1_MD	ADE_LDO1	EN_LDO1[2:0]		
Reset	–	–	–	OTP	OTP	OTP		
Access Type	–	–	–	Write, Read	Write, Read	Write, Read		

BITFIELD	BITS	DESCRIPTION	DECODE
LDO1_MD	4	Operation Mode of LDO1	0 = Low dropout linear regulator (LDO) mode 1 = Load switch (LSW) mode
ADE_LDO1	3	LDO1 Active-Discharge Enable	0 = The active discharge function is disabled. When LDO1 is disabled, its discharge rate is a function of the output capacitance and the external load. 1 = The active discharge function is enabled. When LDO1 is disabled, an internal resistor (RAD_LDO1) is activated from LDO1 to GND to help the output voltage discharge. The output voltage discharge rate is a function of the output capacitance, the external loading, and the internal RAD_LDO1 load.
EN_LDO1	2:0	Enable control for LDO1, selecting either an FPS slot the channel powers-up and powers-down in or whether the channel is forced on or off.	0b000 = FPS slot 0 0b001 = FPS slot 1 0b010 = FPS slot 2 0b011 = FPS slot 3 0b100 = Off irrespective of FPS 0b101 = Same as 0b100 0b110 = On irrespective of FPS 0b111 = Same as 0b110

Typical Application Circuits

Typical Applications Circuit

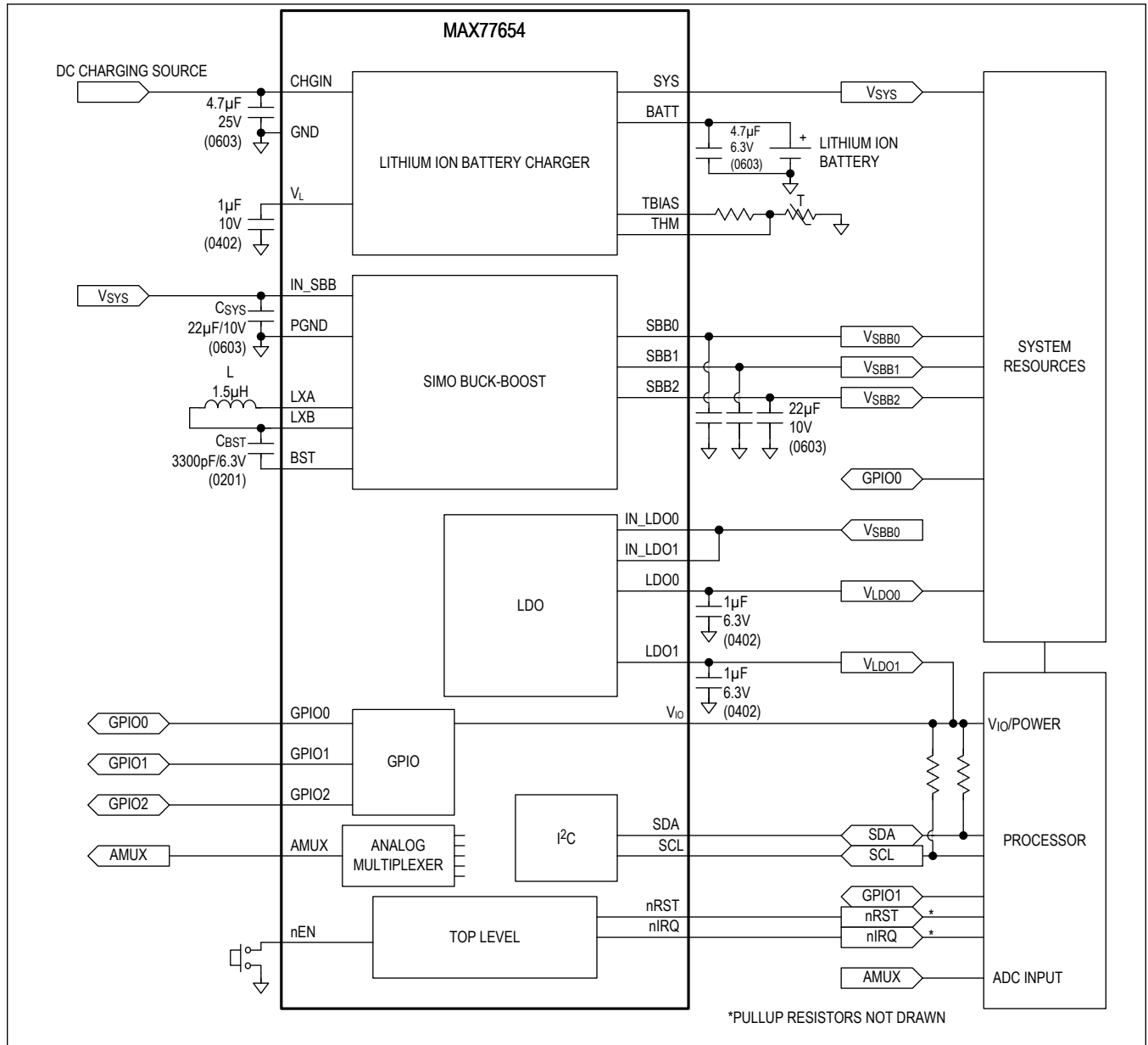

MAX77654

Ultra-Low Power PMIC Featuring Single-Inductor, 3-Output Buck-Boost, 2-LDOs, Power-Path Charger for Small Li+, and Ship Mode

Ordering Information

PART	TEMP RANGE	PIN-PACKAGE	OPTIONS
MAX77654ENV+T*	-40°C to +85°C	30 WLP	
MAX77654AENV+T	-40°C to +85°C	30 WLP	Table 3
MAX77654BENV+T	-40°C to +85°C	30 WLP	Table 3
MAX77654CENV+T**	-40°C to +85°C	30 WLP	Table 3
MAX77654DENV+T	-40°C to +85°C	30 WLP	Table 3
MAX77654FENV+T	-40°C to +85°C	30 WLP	Table 3
MAX77654MENV+T	-40°C to +85°C	30 WLP	Table 3
MAX77654NENV+T	-40°C to +85°C	30 WLP	Table 3
MAX77654ENVN+T*	-40°C to +85°C	30 WLP	
MAX77654AENVN+T	-40°C to +85°C	30 WLP	Table 3

+Denotes a lead(Pb)-free/RoHS-compliant package.

T = Tape and reel.

*Custom samples only. Not for production or stock. Contact factory for more information.

**Future product—[contact factory](#) for availability.

Revision History

REVISION NUMBER	REVISION DATE	DESCRIPTION	PAGES CHANGED
0	5/19	Initial release	—
1	7/19	Updated part decode in Table 3 and <i>Ordering Information</i> table	34, 35, 114
2	2/20	Fixed typographical errors, updated <i>Absolute Maximum Ratings</i> , <i>Electrical Characteristics</i> tables, <i>Typical Operating Characteristics</i> 6, 32, 42, 45, <i>Pin Description</i> table, Table 3, <i>Support Material</i> section, Figure 2, <i>Detailed Description—Global Resources</i> section, Figure 3, <i>nEN Internal Pullup Resistors to V_{CCINT}</i> section, Figure 4, <i>SIMO Features and Benefits</i> section, <i>SIMO Buck Mode</i> section, Table 15, <i>Inductor Selection</i> section, Figures 21, 22, and 23, <i>Summary</i> section, and <i>Ordering Information</i> table	9–14, 19, 21–23, 26, 27, 30, 31, 34–39, 66, 68–70, 72–74, 76, 81, 113
3	7/20	Removed solution size estimate from <i>Benefits and Features</i> section	1
4	7/20	Updated Table 3	34, 35
5	9/20	Updated Figure 7, Figure 8, the <i>SIMO Soft-Start</i> section, and Figures 34, 35, and 36	45, 46, 68, 89–91
6	8/21	Updated Table 3, <i>Register Details</i> section, and <i>Ordering Information</i> table	34–36, 110, 111, 118
7	8/21	Updated <i>Ordering Information</i> table	118
8	9/21	Updated <i>Ordering Information</i> table	118
9	3/23	Updated <i>Benefits and Features</i> , <i>Electrical Characteristics</i> tables, <i>Pin Description</i> table, <i>Inductor Selection</i> section, and <i>Register Details</i> table	1, 18, 20, 72, 100

Looking for pricing, stock, or lifecycle information?

Click below to explore more details on WIN SOURCE:

 [View MAX77654DENV+T on WIN SOURCE](#)

 [Analog Devices Inc. Information](#)

Optimize Your Supply Chain with WIN SOURCE Solutions

-  Global Sourcing Solution
-  Obsolete Management
-  Cost Control Management
-  Shortage Management
-  Alternative Solution
-  Excess Inventory Management