



**THE DATASHEET OF  
TPL51206-DFFR**



### Features

- $V_{IN}$  Voltage Range: 3 V to 5.5 V
- $V_{LDOIN}$  Voltage Range: 1 V to 3.5 V
- $V_{OUT}$  Minimum Output Voltage: 0.5V
- Input Voltage Tracking from  $\frac{1}{2} \times V_{REFIN}$
- 2-A Sink and Source Current Capability for DDR Termination
- Integrated Power MOSFETs
- Output Remote Sensing
- Fast Load-Transient Response
- Built in Soft-Start and UVLO, Current Limit and Thermal Shutdown Protection
- Support DDR, DDR2, DDR3, DDR3L, Low Power DDR3 and DDR4 VTT Power Supply Applications
- Operating Temperature Range:  $-40^{\circ}\text{C}$  to  $+125^{\circ}\text{C}$
- Small Package with  $2 \times 2$  DFN-10
- Pb-Free and are RoHS Compliant

### Applications

- Memory VTT Regulator for DDR, DDR2, DDR3, DDR3L, Low Power DDR3 and DDR4
- Notebooks, Desktops, and Workstations
- Servers, Networking equipment and Datacenters
- Telecom and Base Station

### Description

With the development of main processors in PCs and servers, more and more source double-data-rate (DDR) memories are required in the mainboard, where the input voltage becomes lower and lower, and space limitation becomes higher and higher.

The TPL51206 series devices are 2-A sink and source DDR termination regulators specifically designed for the DDR applications with heavy space limitation. The TPL51206 series devices implement a fast load-transient response and only requires a minimum output capacitance of 10  $\mu\text{F}$ .

The TPL51206 series devices support a remote-sensing function and all power requirements for DDR VTT bus termination. In addition, the TPL51206 series devices provide S3 and S5 control pins can be used to control the power state in DDR applications, setting OUT to high-impedance in S3 state (suspend to RAM) and discharging OUT and REFOUT in S4 or S5 state (suspend to disk).

The TPL51206 series devices are available in the thermally efficient 10-pin  $2 \times 2$  DFN package with thermal pad, and support the operating temperature range from  $-40^{\circ}\text{C}$  to  $+125^{\circ}\text{C}$ .

### Typical Application Schematic

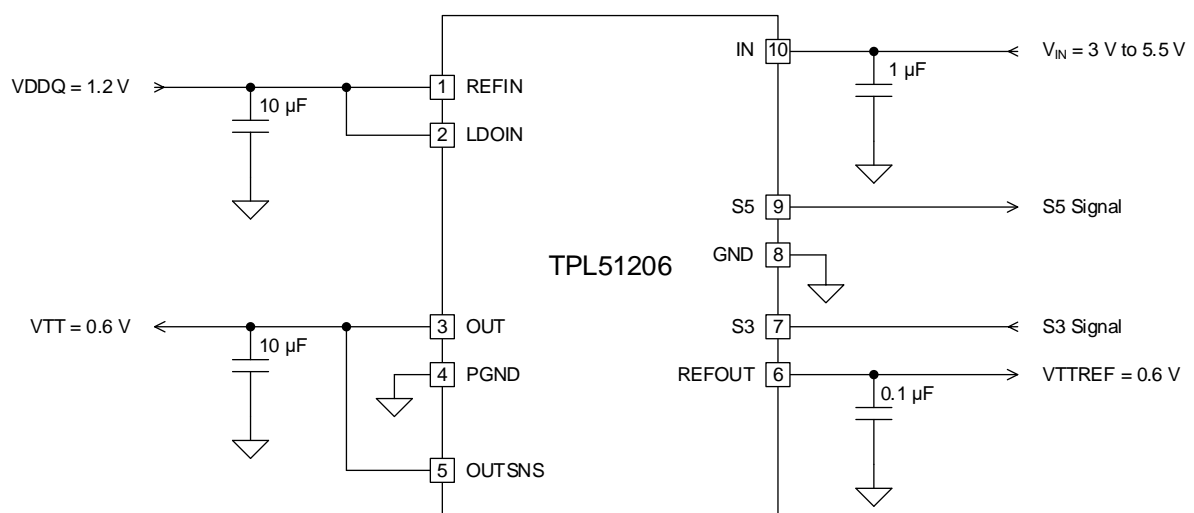

**Product Family Table**

Part Number	Output Current	Orderable Number	Package	Transport Media, Quantity	MSL	Marking information
TPL51206	2 A	TPL51206-DFFR	2×2 DFN-10	3,000	MSL3	206

## Table of Contents

<b>Features</b> .....	<b>1</b>
<b>Applications</b> .....	<b>1</b>
<b>Description</b> .....	<b>1</b>
<b>Typical Application Schematic</b> .....	<b>1</b>
<b>Product Family Table</b> .....	<b>2</b>
<b>Table of Contents</b> .....	<b>3</b>
<b>Revision History</b> .....	<b>4</b>
<b>Pin Configuration and Functions</b> .....	<b>5</b>
<b>Specifications</b> .....	<b>6</b>
Absolute Maximum Ratings .....	6
ESD Ratings .....	6
Recommended Operating Conditions .....	6
Thermal Information .....	6
Electrical Characteristics .....	7
Typical Performance Characteristics .....	9
<b>Detailed Description</b> .....	<b>13</b>
Overview .....	13
Functional Block Diagram .....	13
Feature Description .....	13
<b>Application and Implementation</b> .....	<b>15</b>
Application Information .....	15
Typical Application .....	15
Layout Requirements .....	16
<b>Tape and Reel Information</b> .....	<b>17</b>
<b>Package Outline Dimensions</b> .....	<b>18</b>
2x2 DFN-10 .....	18
<b>IMPORTANT NOTICE AND DISCLAIMER</b> .....	<b>19</b>

## Revision History

Date	Revision	Notes
2020/08/31	Rev.Pre	Preliminary Version
2020/12/31	Rev.A.0	Initial Release

### Pin Configuration and Functions

#### TPL51206 Series

DFN-10 Package

Top View

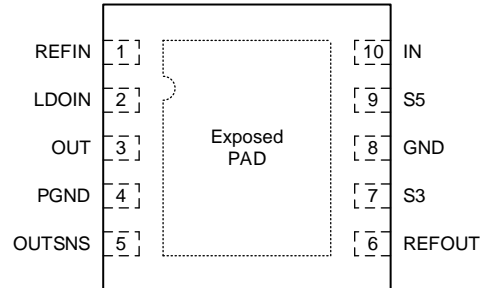

### Pin Functions

NAME	PIN NUMBER	TYPE	DESCRIPTION
GND	8	-	Ground reference pin. Connect GND pin to PCB ground plane directly.
IN	10	I	Regulator power supply input pin. A 1- $\mu$ F or larger ceramic capacitor from IN to ground (as close as possible to IN pin) is required to reduce the jitter from previous-stage power supply.
LDOIN	2	I	LDO power supply input pin.
OUT	3	O	LDO output voltage pin. Total capacitance of 10- $\mu$ F or larger from OUT to ground (as close as possible to OUT pin) is required to ensure regulator stability.
OUTSNS	5	I	LDO output voltage sense pin. Connect SNS to the remote DDR termination bypass capacitors to get accurate remote feedback sensing of OUT voltage.
PGND	4	-	Power ground pin. Connect PGND pin to PCB ground plane directly.
REFIN	1	I	Reference input for REFOUT pin. An 1/2 resistor divider is integrated internally.
REFOUT	6	O	Reference output pin. Connect to ground through a 0.1- $\mu$ F to 1- $\mu$ F ceramic capacitor.
S3	7	I	S3 signal input pin.
S5	9	I	S5 signal input pin.

(1) Exposed PAD must be connected to a large-area ground plane to maximum the thermal performance.

## Specifications

### Absolute Maximum Ratings

		MIN	MAX	UNIT
IN, LDOIN, REFIN, S3, S5		-0.3	6	V
PGND to GND		-0.3	0.3	V
OUT, OUTSNS, REFOUT		-0.3	3.6	V
T <sub>J</sub>	Junction Temperature Range	-40	150	°C
T <sub>STG</sub>	Storage Temperature Range	-55	150	°C
T <sub>L</sub>	Lead Temperature (Soldering 10 sec)		260	°C

(1) Stresses beyond the [Absolute Maximum Ratings](#) may permanently damage the device.

(2) All voltage values are with respect to GND.

### ESD Ratings

		Condition	Minimum Level	Unit
HBM	Human Body Model ESD	ANSI/ESDA/JEDEC JS-001	±2000	V
CDM	Charged Device Model ESD	ANSI/ESDA/JEDEC JS-002	±1500	V

### Recommended Operating Conditions

		MIN	MAX	UNIT
IN	Regulator input voltage	3	5.5	V
LDOIN	LDO input voltage	-0.1	3.5	V
REFIN	LDO input sense voltage	-0.1	3.5	V
S3, S5	S3, S5 signal input voltage	-0.1	5.5	V
OUT	LDO output voltage	-0.1	3.5	V
OUTSNS	LDO output sense voltage	-0.1	3.5	V
REFOUT	Reference output voltage	-0.1	3.5	V
PGND	Power ground voltage to GND	-0.1	0.1	V
T <sub>J</sub>	Junction Temperature Range	-40	125	°C

### Thermal Information

PACKAGE	$\theta_{JA}$	$\theta_{JC,Bottom}$	UNIT
2x2 DFN-10	67.8	13.2	°C/W

## Electrical Characteristics

$T_J = -40^{\circ}\text{C}$  to  $+125^{\circ}\text{C}$  (typical value at  $T_J = 25^{\circ}\text{C}$ ),  $V_{IN} = 5\text{ V}$ ,  $V_{LDOIN} = V_{REFIN}$ ,  $V_{S3} = V_{S5} = 5\text{ V}$ ,  $C_{IN} = 10\ \mu\text{F}$ , and  $C_{OUT} = 10\ \mu\text{F}$ ; unless otherwise noted.

PARAMETER		TEST CONDITIONS	MIN	TYP	MAX	UNIT
<b>Supply Input Voltage and Current</b>						
$V_{IN}$	Input supply voltage range		3		5.5	V
$V_{LDOIN}$	LDO input voltage range				3.5	V
$V_{IN\_UVLO}$	Undervoltage lockout of IN	$T_A = 25^{\circ}\text{C}$ , $V_{IN}$ rising		2.9	3	V
	Hysteresis			180		mV
$I_{IN\_S0}$	Input supply current of IN, S0	$T_A = 25^{\circ}\text{C}$ , $V_{S3} = V_{S5} = 5\text{ V}$ , $V_{LDOIN} = V_{REFIN} = 1.8\text{ V}$ , $I_{OUT} = 0\text{ mA}$		0.89		mA
$I_{IN\_S3}$	Input supply current of IN, S3	$T_A = 25^{\circ}\text{C}$ , $V_{S3} = 0\text{ V}$ , $V_{S5} = 5\text{ V}$ , $V_{LDOIN} = V_{REFIN} = 1.8\text{ V}$ , $I_{OUT} = 0\text{ mA}$		0.34		mA
$I_{IN\_SD}$	Shutdown current of IN, S4 or S5	$T_A = 25^{\circ}\text{C}$ , $V_{S3} = V_{S5} = 0\text{ V}$ , $V_{LDOIN} = V_{REFIN} = 1.8\text{ V}$ , $I_{OUT} = 0\text{ mA}$		0.1	5	$\mu\text{A}$
$I_{LDOIN\_S0}$	Input current of LDOIN, S0	$T_A = 25^{\circ}\text{C}$ , $V_{S3} = V_{S5} = 5\text{ V}$ , $V_{LDOIN} = V_{REFIN} = 1.8\text{ V}$ , $I_{OUT} = 0\text{ mA}$		2	10	$\mu\text{A}$
$I_{LDOIN\_S3}$	Input current of LDOIN, S3	$T_A = 25^{\circ}\text{C}$ , $V_{S3} = 0\text{ V}$ , $V_{S5} = 5\text{ V}$ , $V_{LDOIN} = V_{REFIN} = 1.8\text{ V}$ , $I_{OUT} = 0\text{ mA}$		2	10	$\mu\text{A}$
$I_{LDOIN\_SD}$	Shutdown current of LDOIN, S4 or S5	$T_A = 25^{\circ}\text{C}$ , $V_{S3} = V_{S5} = 0\text{ V}$ , $V_{LDOIN} = V_{REFIN} = 1.8\text{ V}$ , $I_{OUT} = 0\text{ mA}$		0.2	5	$\mu\text{A}$
<b>Reference Input and Output</b>						
$I_{REFIN}$	Input current of REFIN	$V_{REFIN} = 1.8\text{ V}$		30		$\mu\text{A}$
$V_{REFOUT}$	Reference output voltage			$\frac{V_{REFIN}}{2}$		V
$V_{REFOUT\_TOL}$	Tolerance of REFOUT to REFIN	$ I_{REFOUT}  \leq 10\text{ mA}$ , $1.2\text{ V} \leq V_{REFIN} \leq 1.8\text{ V}$	49%		51%	
		$ I_{REFOUT}  \leq 100\ \mu\text{A}$ , $1.2\text{ V} \leq V_{REFIN} \leq 1.8\text{ V}$	49%		51%	
$I_{REFOUT\_SRC}$	Source current limit of REFOUT	$V_{REFIN} = 1.8\text{ V}$ , $V_{REFOUT} = 0\text{ V}$	10			mA
$I_{REFOUT\_SNK}$	Sink current limit of REFOUT	$V_{REFIN} = 0\text{ V}$ , $V_{REFOUT} = 1.8\text{ V}$	10			mA
$I_{REFOUT\_DIS}$	Discharge current of REFOUT	$T_A = 25^{\circ}\text{C}$ , $V_{S3} = V_{S5} = 0\text{ V}$ , $V_{REFOUT} = 0.5\text{ V}$		8		mA
<b>Regulated Output Voltage and Current</b>						
$V_{OUT}$	Output voltage, $V_{OUT} = \frac{V_{REFIN}}{2}$	$ I_{OUT}  \leq 10\text{ mA}$ , $1.2\text{ V} \leq V_{REFIN} \leq 1.8\text{ V}$	-20		20	mV
		$ I_{OUT}  \leq 1\text{ A}$ , $1.2\text{ V} \leq V_{REFIN} \leq 1.8\text{ V}$	-30		30	mV
		$ I_{OUT}  \leq 2\text{ A}$ , $1.2\text{ V} \leq V_{REFIN} \leq 1.8\text{ V}$	-40		40	mV
$I_{OUT\_SRC}$	Source current limit of OUT	$V_{REFIN} = 1.8\text{ V}$ , $V_{OUT} = V_{OUTSNS} = 0.7\text{ V}$	2			A
$I_{OUT\_SNK}$	Sink current limit of OUT	$V_{REFIN} = 1.8\text{ V}$ , $V_{OUT} = V_{OUTSNS} = 1.1\text{ V}$	2			A
$I_{OUT\_LKG}$	Leakage current of OUT	$T_A = 25^{\circ}\text{C}$ , $V_{S3} = 0\text{ V}$ , $V_{S5} = 5\text{ V}$ , $V_{OUT} = V_{REFOUT}$		1	10	$\mu\text{A}$
$I_{OUT\_DIS}$	Discharge current of OUT	$T_A = 25^{\circ}\text{C}$ , $V_{S3} = V_{S5} = V_{REFIN} = 0\text{ V}$ , $V_{OUT} = 0.5\text{ V}$		50		mA
$I_{OUTSNS\_BIAS}$	Input bias current of OUTSNS	$V_{S3} = V_{S5} = 5\text{ V}$ , $V_{OUTSNS} = V_{REFOUT}$	-0.1		0.1	$\mu\text{A}$
$I_{OUTSNS\_LKG}$	Leakage current of OUTSNS	$V_{S3} = 0\text{ V}$ , $V_{S5} = 5\text{ V}$ , $V_{OUTSNS} = V_{REFOUT}$	-0.1		0.1	$\mu\text{A}$

## Electrical Characteristics (continued)

$T_J = -40^{\circ}\text{C}$  to  $+125^{\circ}\text{C}$  (typical value at  $T_J = 25^{\circ}\text{C}$ ),  $V_{IN} = 5\text{ V}$ ,  $V_{LDOIN} = V_{REFIN}$ ,  $V_{S3} = V_{S5} = 5\text{ V}$ ,  $C_{IN} = 10\text{ }\mu\text{F}$ , and  $C_{OUT} = 10\text{ }\mu\text{F}$ ; unless otherwise noted.

S3 and S5						
$V_{IH}$	High-level input of S3 and S5		1.7			V
$V_{IL}$	Low-level input of S3 and S5				0.5	V
$V_{HL\_SYS}$	Hysteresis of S3 and S5			0.3		V
$I_{HL\_LKG}$	Leakage current of S3 and S5		-1		1	$\mu\text{A}$
Temperature Range						
$T_{SD}$	Thermal shutdown threshold	Temperature increasing		160		$^{\circ}\text{C}$
	Hysteresis			20		$^{\circ}\text{C}$

### Typical Performance Characteristics

$T_J = -40^{\circ}\text{C}$  to  $+125^{\circ}\text{C}$  (typical value at  $T_J = 25^{\circ}\text{C}$ ),  $V_{IN} = 5\text{ V}$ ,  $V_{LDOIN} = V_{REFIN}$ ,  $V_{S3} = V_{S5} = 5\text{ V}$ ,  $C_{IN} = 10\ \mu\text{F}$ , and  $C_{OUT} = 10\ \mu\text{F}$ ; unless otherwise noted.

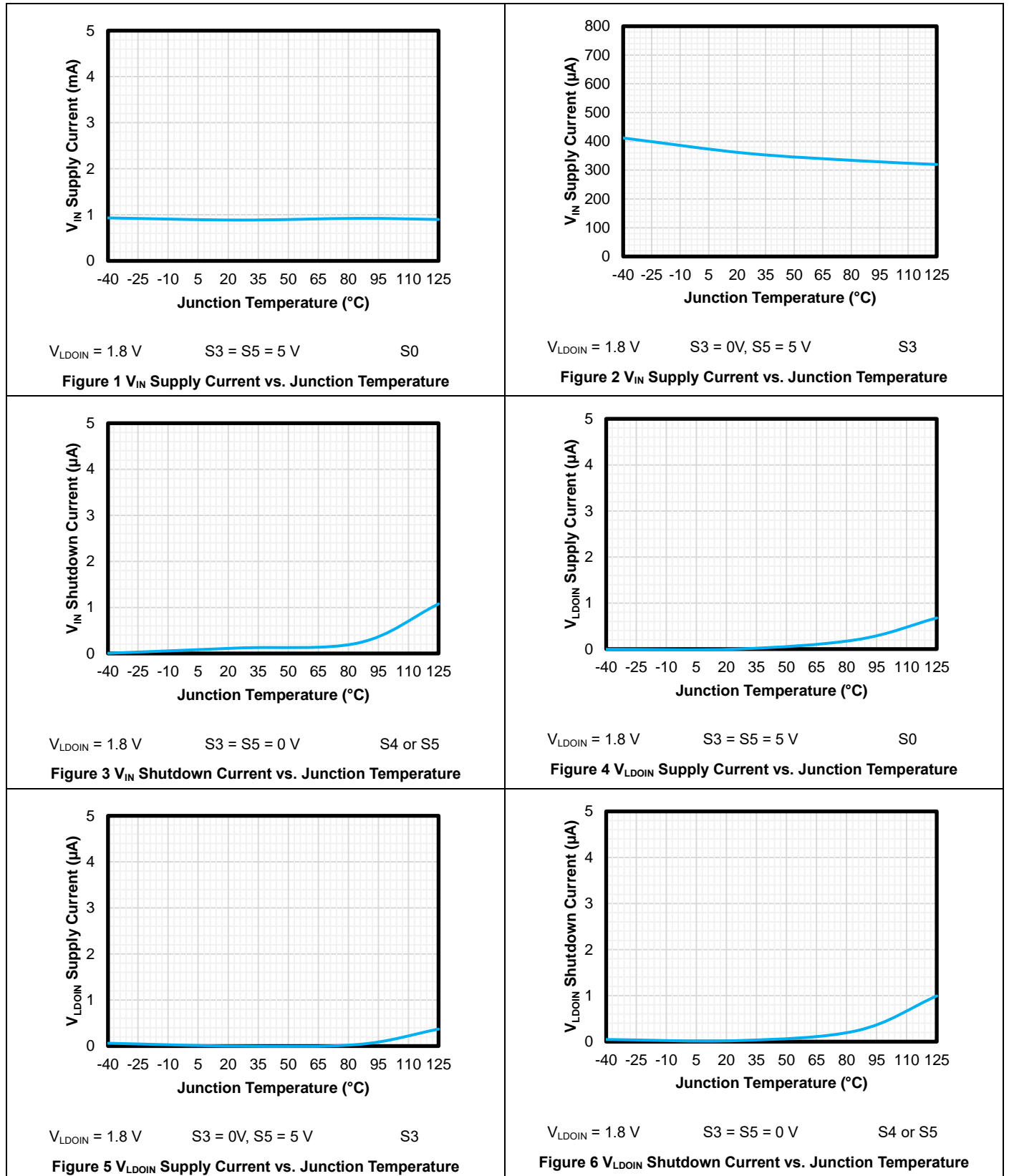

Typical Performance Characteristics (continued)

$T_J = -40^{\circ}\text{C}$  to  $+125^{\circ}\text{C}$  (typical value at  $T_J = 25^{\circ}\text{C}$ ),  $V_{IN} = 5\text{ V}$ ;  $V_{LDOIN} = V_{REFIN}$ ,  $V_{S3} = V_{S5} = 5\text{ V}$ ,  $C_{IN} = 10\ \mu\text{F}$ , and  $C_{OUT} = 10\ \mu\text{F}$ ; unless otherwise noted.

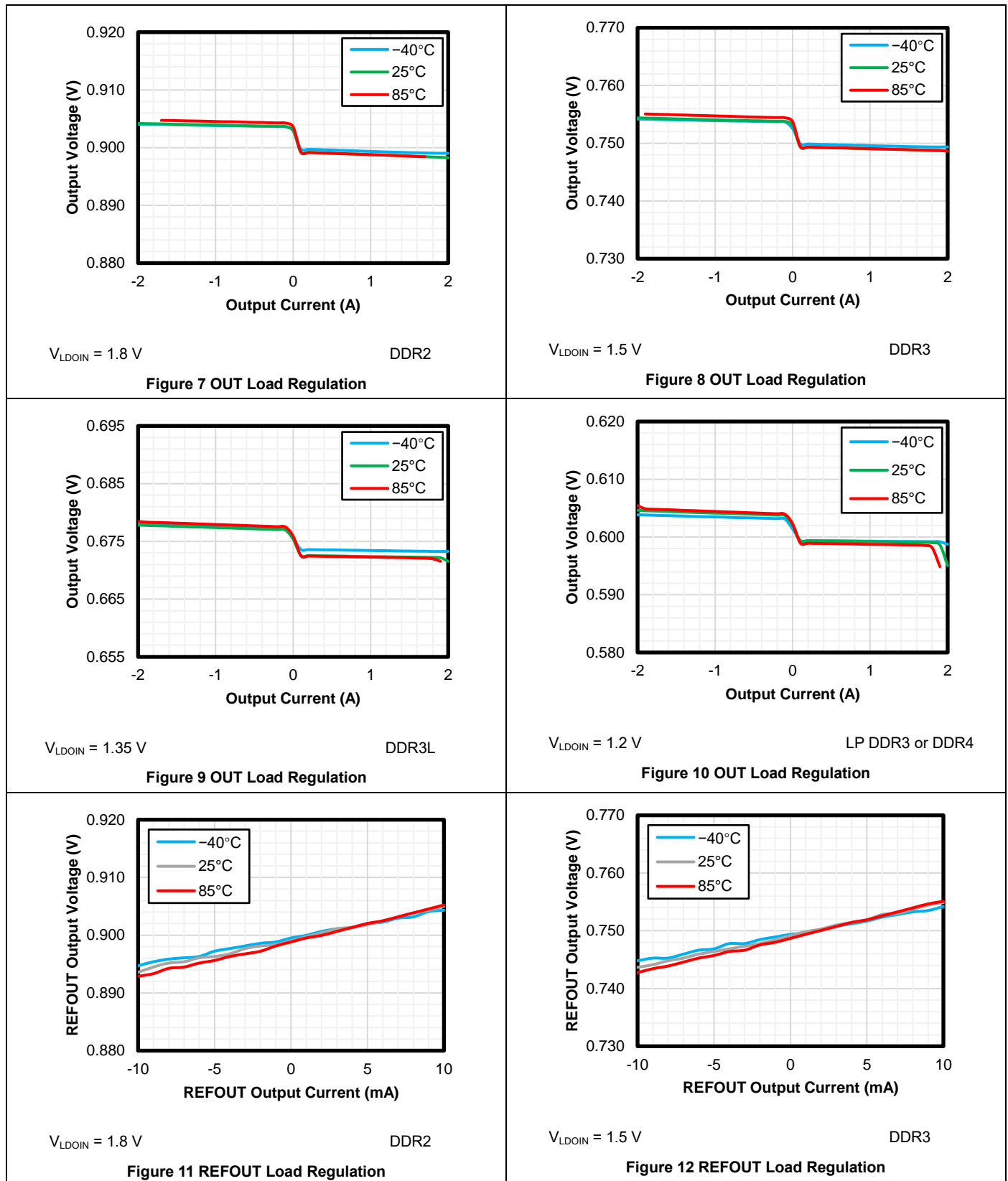

### Typical Performance Characteristics (continued)

$T_J = -40^{\circ}\text{C}$  to  $+125^{\circ}\text{C}$  (typical value at  $T_J = 25^{\circ}\text{C}$ ),  $V_{IN} = 5\text{ V}$ ;  $V_{LDOIN} = V_{REFIN}$ ,  $V_{S3} = V_{S5} = 5\text{ V}$ ,  $C_{IN} = 10\ \mu\text{F}$ , and  $C_{OUT} = 10\ \mu\text{F}$ ; unless otherwise noted.

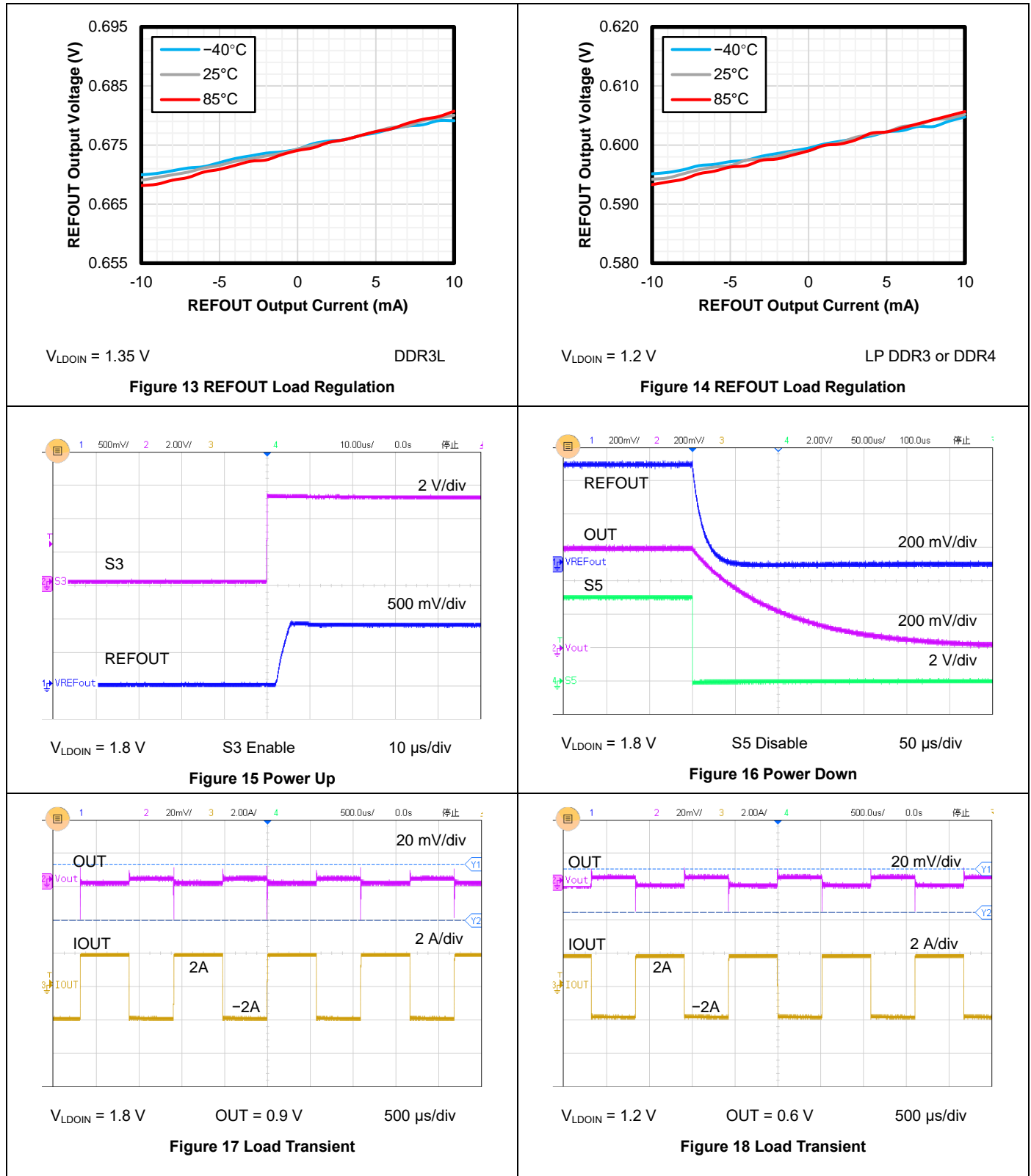

### Typical Performance Characteristics (continued)

$T_J = -40^{\circ}\text{C}$  to  $+125^{\circ}\text{C}$  (typical value at  $T_J = 25^{\circ}\text{C}$ ),  $V_{IN} = 5\text{ V}$ ;  $V_{LDOIN} = V_{REFIN}$ ,  $V_{S3} = V_{S5} = 5\text{ V}$ ,  $C_{IN} = 10\ \mu\text{F}$ , and  $C_{OUT} = 10\ \mu\text{F}$ ; unless otherwise noted.

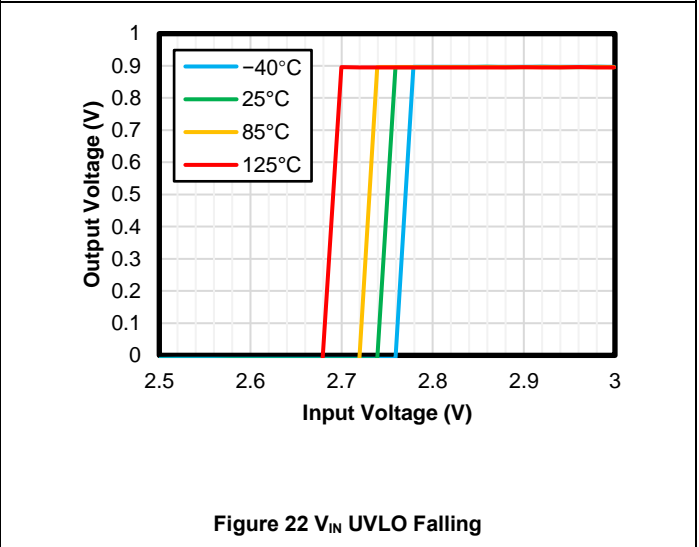
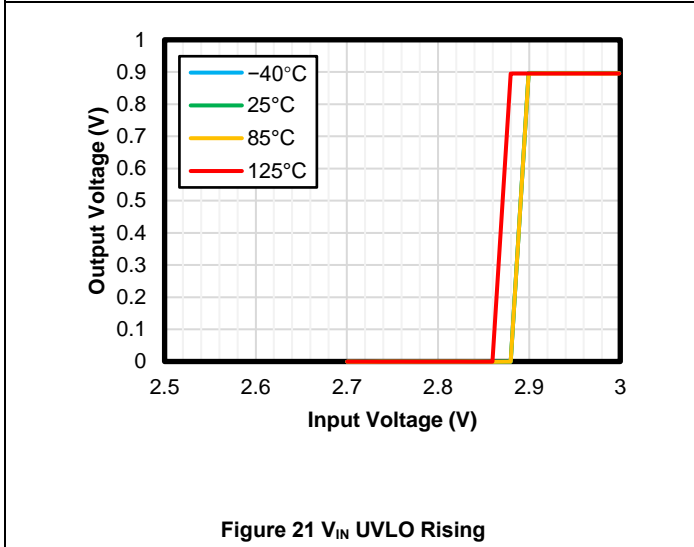
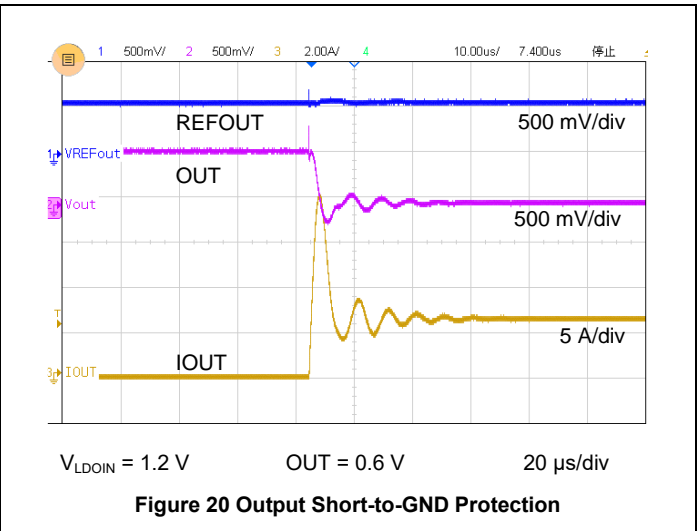
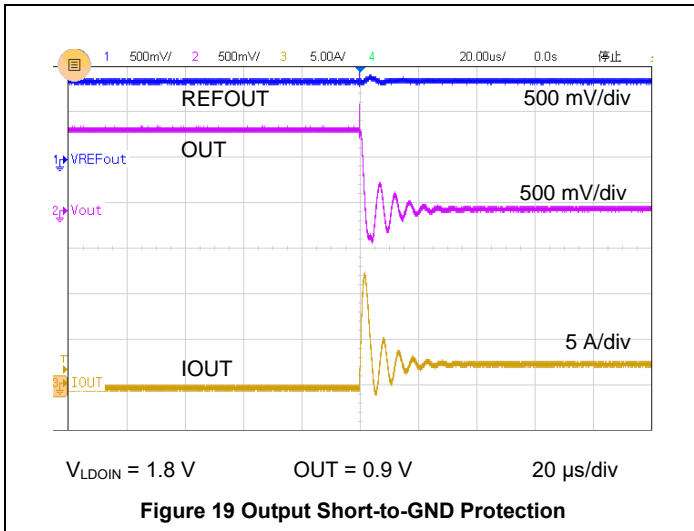

## Detailed Description

### Overview

The TPL51206 series devices are 2-A sink and source DDR termination regulators specifically designed for the DDR applications with heavy space limitation. The TPL51206 series devices implement a fast load-transient response and only requires a minimum output capacitance of 10  $\mu$ F.

The TPL51206 series devices support a remote-sensing function and all power requirements for DDR VTT bus termination. In addition, the TPL51206 series devices provide S3 and S5 control pins can be used to control the power state in DDR applications, setting OUT to high-impedance in S3 state (suspend to RAM) and discharging OUT and REFOUT in S4 or S5 state (suspend to disk).

### Functional Block Diagram

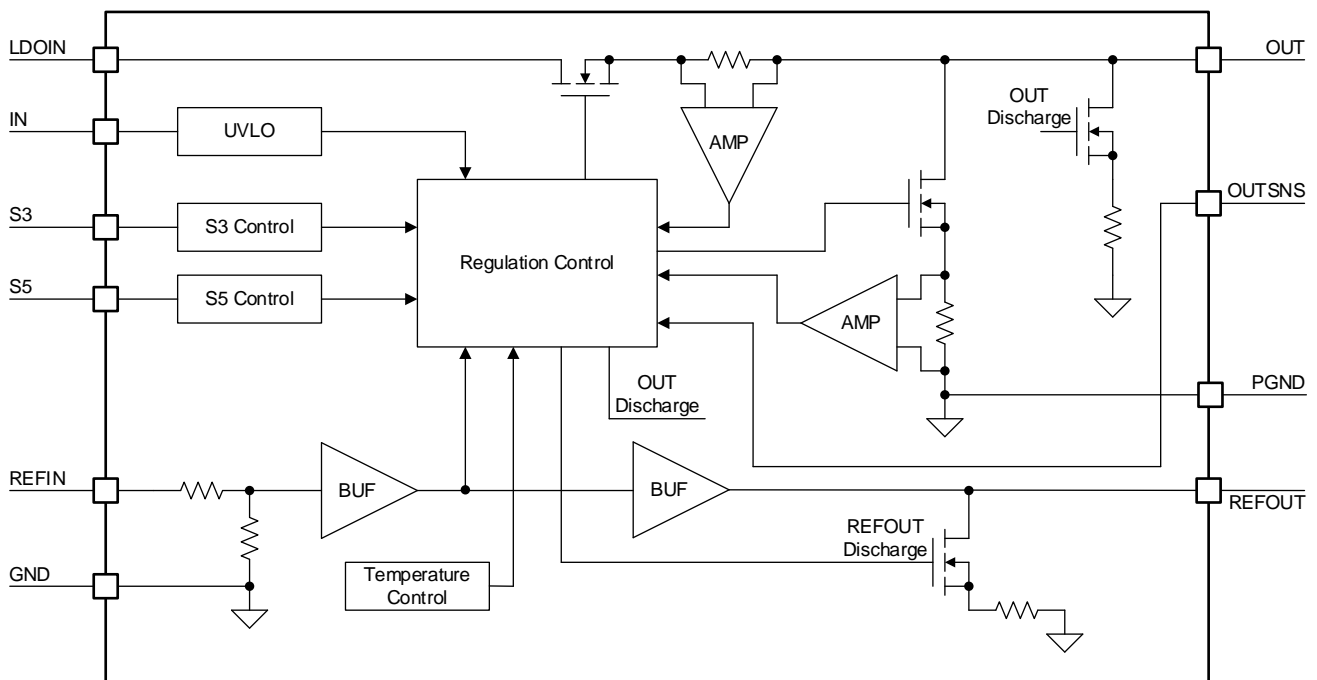

Figure 23 Functional Block Diagram

## Feature Description

### Sink and Source Regulator (OUT and OUTSNS)

The TPL51206 series devices are 2-A sink and source DDR termination regulators specifically designed for the DDR applications with heavy space limitation. The TPL51206 series integrate a high-performance, low-dropout linear regulator with fast-feedback loop that can support fast load transient response with small ceramic capacitors. To get tight regulation tolerance, the remote sensing pin, OUTSNS pin, must be connected to OUT pin through a separate trace from high current path.

### Voltage Reference (LDOIN, REFIN and REFOUT)

The TPL51206 series uses the voltage at the REFIN pin as the reference input, and the reference output at the REFOUT pin exactly follow the  $1/2 \times V_{REFIN}$  within the tolerance of  $V_{REFOUT\_TOL}$ . When the TPL51206 series are configured for standard DDR applications, the LDOIN pin and the REFIN pin are directly connected with input voltage range from 1 V to 3.5 V, and the voltage at the REFIN pin is divided by half through an internal resistor divider.

The REFOUT pin of the TPL51206 series implement a minimum 10 mA of sink or source current capability. During normal operation, the REFOUT pin cannot be open, and a 0.1- $\mu$ F to 1- $\mu$ F X5R or better ceramic capacitor is required for stable operation.

### IN Under-voltage Lockout

The TPL51206 series use an under-voltage lockout circuit to keep the regulator shut off until IN voltage exceeds the rising UVLO

threshold of IN.

### S3 and S5 Control

The TPL51206 series integrate the S3 and S5 pins to control the device state. Table 1 shows the device state with different S3 and S5 logic level combination, and the corresponding status of REFOUT and OUT.

Table 1 S3 and S5 Control Table

STATE	S3	S5	REFOUT	OUT
S0	HIGH	HIGH	ON	ON
S3	LOW	HIGH	ON	OFF (High-Z)
S4, S5	LOW	LOW	OFF (Discharge)	OFF (Discharge)

- In S4 or S5 state, S3 = S5 = LOW, all the outputs are turn-off and discharge to power ground.
- In S3 state, S3 = LOW and S5 = HIGH, the OUT pin is turn-off in high-impedance state.
- In S0 state, S3 = S5 = HIGH, the device in normal operation mode.

### Power Sequence Control

It is recommended to power up and power down the TPL51206 series with the power sequence showed in Figure 24.

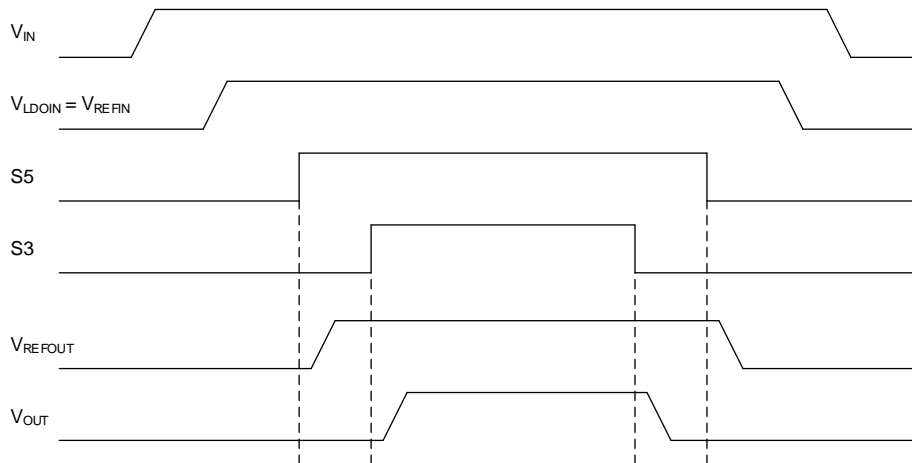

Figure 24 Power Up and Down Sequence Control

### OUT Over-Current Protection

The TPL51206 series integrate a constant over-current protection. When the absolute value of output sink or source current is greater than 2A, the current is limited to  $I_{OUT\_SNK}$  or  $I_{OUT\_SRC}$ , and the output voltage is out of regulation.

### Over-Temperature Protection

The recommended operating junction temperature range is  $-40^{\circ}\text{C}$  to  $125^{\circ}\text{C}$ . When the junction temperature is between  $125^{\circ}\text{C}$  and the thermal shutdown (TSD) threshold, the regulator can still work well, but it will reduce the device lifetime for long-term using.

The over-temperature protection works when the junction temperature exceeds the thermal shutdown (TSD) threshold, which turns off the regulator immediately. Until when the device cools down and the junction temperature falls below the thermal shutdown threshold minus thermal shutdown hysteresis, the regulator turns on again.

### Application and Implementation

**NOTE**

Information in the following applications sections is not part of the 3PEAK's component specification and 3PEAK does not warrant its accuracy or completeness. 3PEAK's customers are responsible for determining suitability of components for their purposes. Customers should validate and test their design implementation to confirm system functionality.

### Application Information

The TPL51206 series devices are 2-A sink and source DDR termination regulators specifically designed for the DDR applications. The following application schematic shows a typical usage of the TPL51206 series.

### Typical Application

#### Adjustable Output Operation

Figure 25 shows the typical application schematic of the TPL51206 series in DDR4 applications.

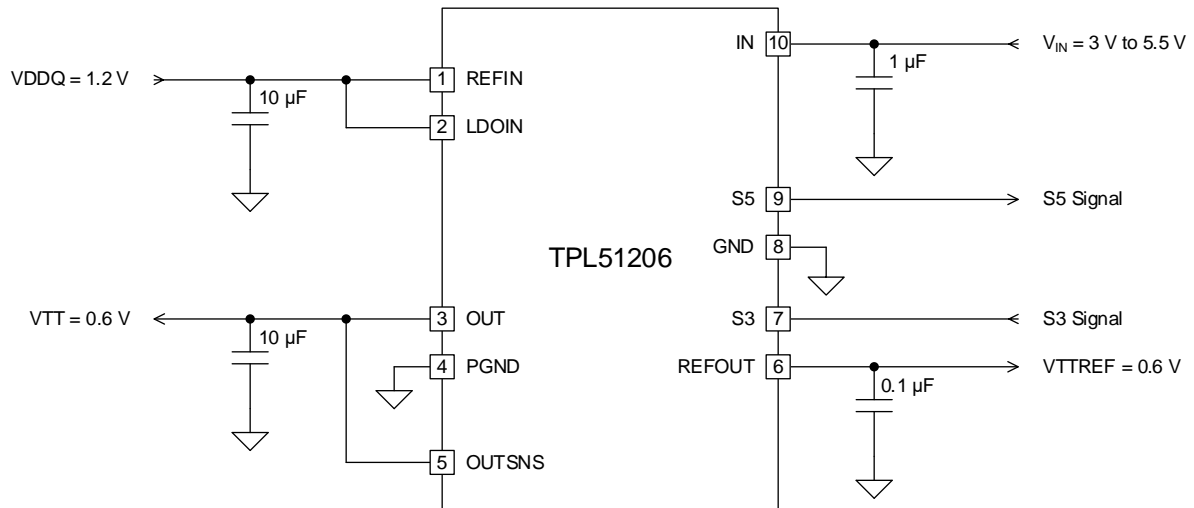

Figure 25 Typical Application Schematic

#### IN Input Capacitor

3PEAK recommends placing a 1-µF or greater capacitor with a 0.1-µF bypass capacitor in parallel close to IN pin to keep the input voltage stable. The voltage rating of the capacitors must be greater than the maximum input voltage.

#### LDOIN Input Capacitor

3PEAK recommends placing a 10-µF or greater capacitor with a 0.1-µF bypass capacitor in parallel close to LDOIN pin to keep the voltage stable during transient. More input capacitors are required if there are large output capacitors used at the OUT pin. It is suggested to place input capacitors with a half of the output capacitance value at the LDOIN pin.

#### Output Capacitor

To ensure stable operation, the TPL51206 series requires output capacitors of 10 µF or greater. 3PEAK recommends selecting X5R- or X7R-type ceramic capacitor with minimum equivalent series resistance (ESR) and equivalent series inductance (ESL). The output capacitors must be placed as close to the OUT pin as possible.

#### Power Dissipation

During normal operation, LDO junction temperature should not exceed 125°C. Using below equations to calculate the power dissipation and estimate the junction temperature.

The power dissipation can be calculated using [Equation 1](#).

$$P_D = (V_{IN} - V_{OUT}) \times I_{OUT} + V_{IN} \times I_{GND} \quad (1)$$

The junction temperature can be estimated using [Equation 2](#).  $\theta_{JA}$  is the junction-to-ambient thermal resistance.

$$T_J = T_A + P_D \times \theta_{JA} \quad (2)$$

## Layout Requirements

- Both input capacitors and output capacitors must be placed as close to the device pins as possible.
- Suggest bypass the input pin to ground with a 0.1  $\mu$ F bypass capacitor. The loop area formed by the bypass capacitor connection, voltage input pin and the ground pin of the system must be as small as possible.
- Suggest use wide trace lengths or thick copper weight to minimize  $I \times R$  drop and heat dissipation.
- The GND pin and the PGND pin must be connected to the thermal pad with multiple thermal vias as many as possible connected to the internal ground planes.

Tape and Reel Information

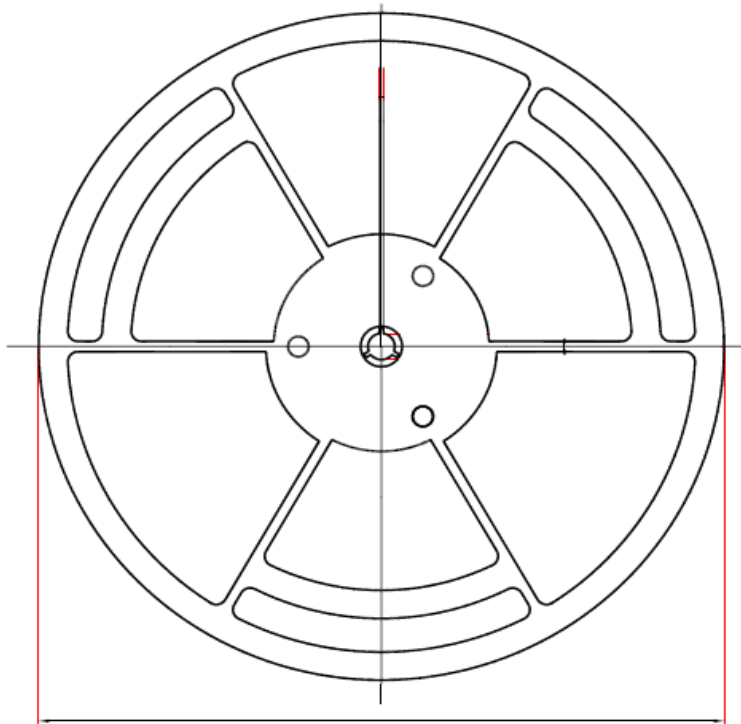

D1: Reel Diameter

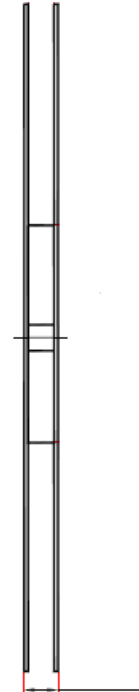

W1: Reel Width

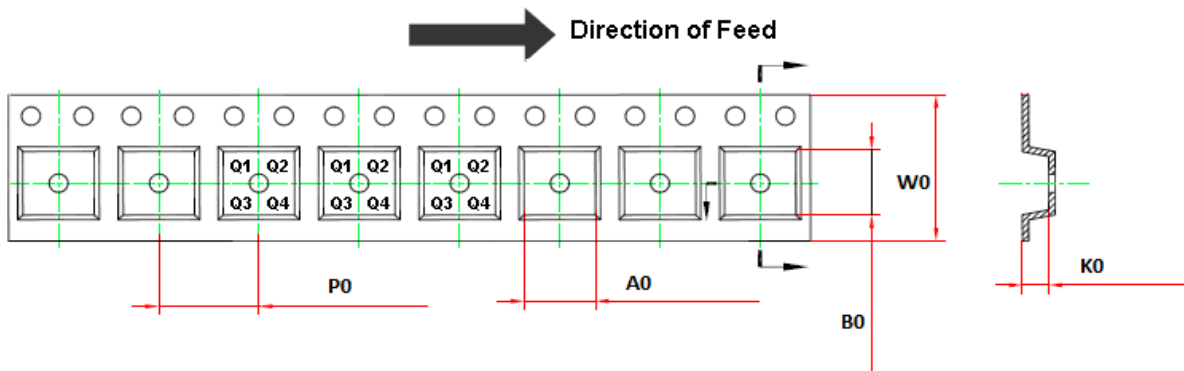

Order Number	Package	D1 (mm)	W1 (mm)	A0 (mm)	B0 (mm)	K0 (mm)	P0 (mm)	W0 (mm)	Pin1 Quadrant
TPL51206-DFFR	2x2 DFN-10	180	13.1	2.3	2.3	1.1	4	8	Q2

Package Outline Dimensions

2x2 DFN-10

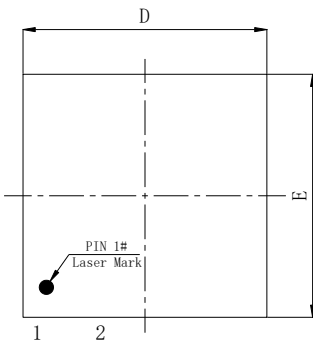

TOP VIEW

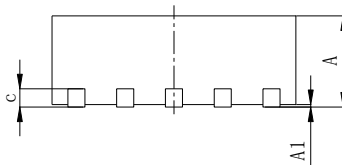

SIDE VIEW

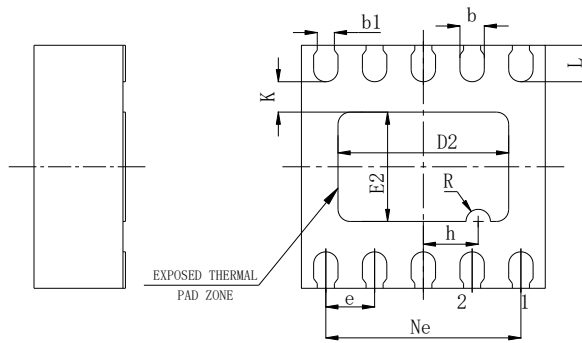

BOTTOM VIEW

SYMBOL	MILLIMETER		
	MIN	NOM	MAX
A	0.70	0.75	0.80
A1	0	0.02	0.05
b	0.15	0.20	0.25
b1	0.09	0.14	0.19
c	0.15	0.20	0.25
D	1.90	2.00	2.10
D2	1.30	1.40	1.50
e	0.40BSC		
Ne	1.60BSC		
E	1.90	2.00	2.10
E2	0.80	0.90	1.00
L	0.25	0.30	0.35
h	0.40	0.45	0.50
R	0.05	0.10	0.15
K	0.20	0.25	0.30
L/载体尺寸	1.10X1.80		

## IMPORTANT NOTICE AND DISCLAIMER

**Copyright**© 3PEAK 2012-2023. All rights reserved.

**Trademarks.** Any of the 思瑞浦 or 3PEAK trade names, trademarks, graphic marks, and domain names contained in this document /material are the property of 3PEAK. You may NOT reproduce, modify, publish, transmit or distribute any Trademark without the prior written consent of 3PEAK.

**Performance Information.** Performance tests or performance range contained in this document/material are either results of design simulation or actual tests conducted under designated testing environment. Any variation in testing environment or simulation environment, including but not limited to testing method, testing process or testing temperature, may affect actual performance of the product.

**Disclaimer.** 3PEAK provides technical and reliability data (including data sheets), design resources (including reference designs), application or other design recommendations, networking tools, security information and other resources "As Is". 3PEAK makes no warranty as to the absence of defects, and makes no warranties of any kind, express or implied, including without limitation, implied warranties as to merchantability, fitness for a particular purpose or non-infringement of any third-party's intellectual property rights. Unless otherwise specified in writing, products supplied by 3PEAK are not designed to be used in any life-threatening scenarios, including critical medical applications, automotive safety-critical systems, aviation, aerospace, or any situations where failure could result in bodily harm, loss of life, or significant property damage. 3PEAK disclaims all liability for any such unauthorized use.

## Looking for pricing, stock, or lifecycle information?

Click below to explore more details on WIN SOURCE:

- ⊖ [View TPL51206-DFFR on WIN SOURCE](#)
- ⊖ [3Peak Information](#)

## Optimize Your Supply Chain with WIN SOURCE Solutions

- ✓ Global Sourcing Solution
- ✓ Obsolete Management
- ✓ Cost Control Management
- ✓ Shortage Management
- ✓ Alternative Solution
- ✓ Excess Inventory Management