



**THE DATASHEET OF  
TAP600K1R0E**



# TAP600 Series

## 600 Watt Heat Sinkable Planar



Ohmite's TAP600 delivers 600 watts of reliable power to a variety of power conditioning, power transmission, and power control applications. These resistors can be designed for liquid or air cooled heat sink systems. Applications include variable speed drives, power supplies, robotics, motor control, and other control devices.

### FEATURES

- Dielectric Strength up to 12KV
- Special Design for Low Inductance and Capacitance Values
- Contacts allow for easy load connection with M5 screws (not included) available with M4 as special request. Thread depth 7mm
- Encapsulated with a special resin filled epoxy casing with a large creepage distance to mass, large air distance between terminals, and a high insulation resistance (CTI 600).
- Materials meet the requirements of UL94-V0



### CHARACTERISTICS

<b>Resistance Values</b>	0.25Ω to 100KΩ
<b>Resistance Tolerance</b>	±10% Std., 5% available on request.
<b>Temperature Coefficient</b>	±150ppm/°C (others upon request)
<b>Maximum Working Voltage</b>	5,000V DC, higher voltage on request, not exceeding max. power
<b>Power Rating</b>	600W at 70°C heat sink temperature or 85°C bottom case temperature. This value is only valid by using a thermal conduction to the heat sink Rth -cs<0.025°C/W. The value can be reached by using thermal transfer compound with a heat conductivity of 1w/mk. The flatness of the cooling plate must be better than 0.05mm overall. The roughness of the surface should not exceed 6.4µm.
<b>Dielectric Strength Voltage</b>	7K Vrms, 50Hz, 1min standard; up to 12k Vrms available
<b>Single Shot Voltage</b>	Up to 12KV Normwave (1.5/50 µsec)
<b>Insulation Resistance</b>	10GΩ min. at 500V
<b>Creeping Distance</b>	42mm min.
<b>Air Distance</b>	14mm min.
<b>Inductance</b>	≤80nH
<b>Capacitance/Mass</b>	≤110pF
<b>Capacitance/Parallel</b>	≤40pF
<b>Operation Temperature</b>	-55°C to +150°C
<b>Max. Torque for Contacts</b>	2 Nm
<b>Max. Torque for Mounting</b>	1.8 Nm
<b>Derating (thermal resist.)</b>	8.33W/°C (0.12°C/W) element to case

Test	Method	Typical Results - ΔR
<b>Short Time Overload</b>	1000 W/10 Sec. @ 70°C	0.4%
<b>Humidity Steady State</b>	56 Days/40°C/ 95°C	0.25%
<b>Temp. Cycling</b>	-55/+125/5 Cycles	0.20%
<b>Shock</b>	40g/4,000 Times	0.25%
<b>Vibrations</b>	2 - 500Hz/10g	0.25%
<b>Load Life 1,000 Cycles</b>	Pn 30 min. ON/30 min. OFF	0.40%
<b>Terminal Strength of Contacts</b>	200N	0.05%

### Derating

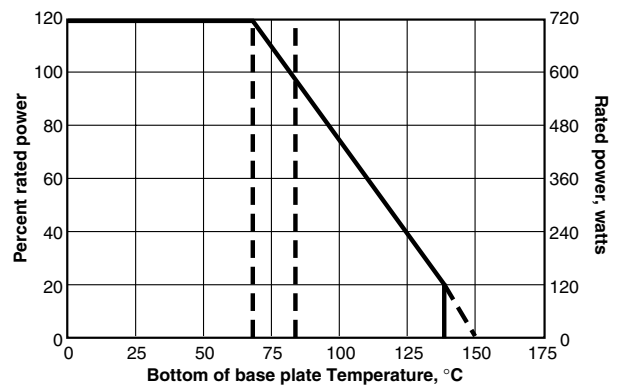

(continued)

# TAP600 Series

## 600 Watt Heat Sinkable Planar

### DIMENSIONS

(iin./mm)

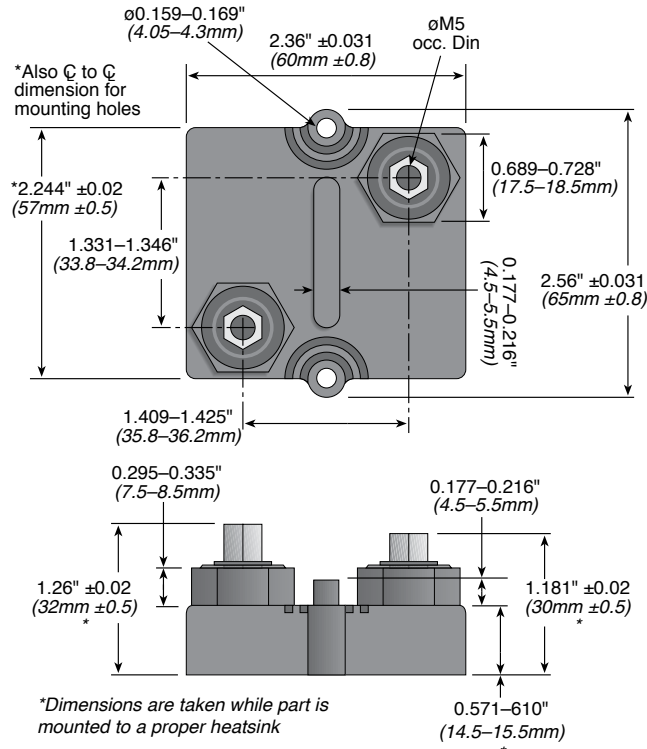

### ORDERING INFORMATION

RoHS compliant  
Non-compliant version  
unavailable

**TAP600K5R0E**

Style	Tolerance	Resistance
J = 5%		1 Ohm = 1R0
K = 10%, Std.		10 Ohm = 10R
L = 20%		1000 Ohm = 1K0

#### Standard Values

10% tol.

TAP600KR25E  
TAP600KR33E  
TAP600KR50E  
TAP600K100E  
TAP600K10KE  
TAP600K10RE  
TAP600K1K0E  
TAP600K1R0E

TAP600K4R0E  
TAP600K40RE  
TAP600K20RE  
TAP600K200E  
TAP600K22RE  
TAP600K2R0E  
TAP600K3R0E  
TAP600K50RE

TAP600K5R0E  
TAP600K7K5E  
TAP600K7R5E  
TAP600K75RE  
TAP600K750E  
TAP600K30RE  
TAP600K500E

5% tol.

TAP600J1R0E  
TAP600J10RE  
TAP600J50RE  
TAP600J100E  
TAP600J500E  
TAP600J1K0E

### THIS PRODUCT IS DESIGNED FOR USE WITH PROPER HEATSINKING.

Maximum base plate temperature of the resistor must be monitored and kept within specified limits to establish the power rating. Best technique is to attach a thermocouple to the side of the base plate of the resistor. Temperature of plastic housing or heat sink cannot be used to establish rating of the resistor. The Ohmite CP4 (<https://www.ohmite.com/cp4-series-chillplate/>) is an example of properly designed heat sink.

## Looking for pricing, stock, or lifecycle information?

Click below to explore more details on WIN SOURCE:

 [View TAP600K1R0E on WIN SOURCE](#)

 [Ohmite Information](#)

## Optimize Your Supply Chain with WIN SOURCE Solutions

-  Global Sourcing Solution
-  Obsolete Management
-  Cost Control Management
-  Shortage Management
-  Alternative Solution
-  Excess Inventory Management