

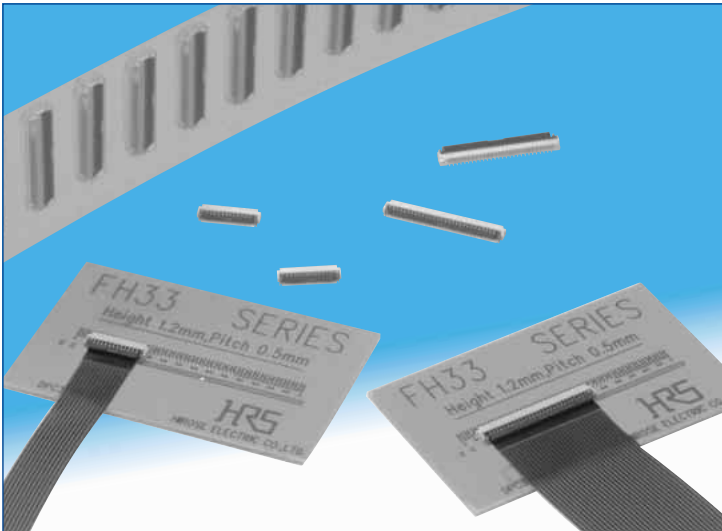

**THE DATASHEET OF
FH33-12S-0.5SH(10)**



FH33 Series



Features

1. Low-profile, small PCB mounting area

Narrow width of only 2.5 mm reduced the board footprint by approximately 17% to 57%, as compared to several similar FH Series HRS connectors.

2. Various contact pitch (0.4mm, 0.5mm, 1mm pitch) available

In addition to standard 0.5mm pitch, 0.4mm pitch, 1mm pitch also available.

3. Increased FPC/FFC retention force

- In the horizontal direction: Approximately 2.0 times (compared to 0.5mm pitch FH12 series.)
- In the vertical direction: Approximately 1.7 times (compared to 0.5mm pitch FH19 series.)

4. Conductive traces on the PCB can run under the connector

No exposed contacts on the bottom of the connector.

5. One finger operation of the actuator

Proven (in several other Hirose's connectors) Flip-Lock® rotating actuator assures reliable mechanical and electrical connection with FPC/FFC, confirming it with a definite tactile feel.

6. Easy FPC insertion and reliable electrical connection

Proven Flip Lock actuator allows easy insertion of FPC/FFC and provides a tactile sensation when fully closed, confirming complete electrical and mechanical connection.

7. Accepts standard FPC thickness

0.3mm thick standard Flexible Printed Circuit (FPC) and Flexible Flat Cable (FFC) can be used.

8. Board placement with automatic equipment

Flat upper surface and tape and reel packaging facilitate vacuum pick-up and placement. Standard reel packaging contains 5000 connectors.

9. Halogen-free* (FH33J Series)

*As defined by IEC61249-2-21
Br-900ppm maximum, Cl-900ppm maximum,
Cl + Br combined-1,500ppm maximum

Increased FPC retention force

● Small size

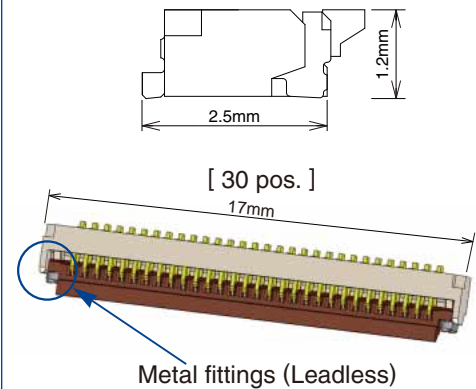

● Can be mounted over conductive traces.

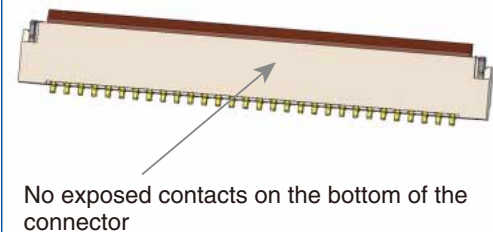

● Simple operation

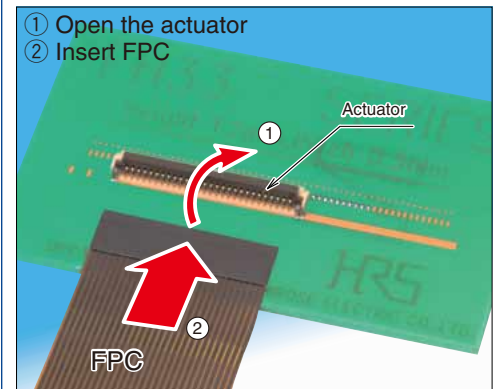

● Locked condition

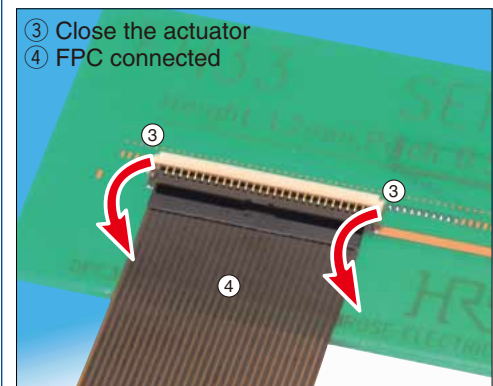

Product Specifications

Ratings	Current rating	0.5 A (0.4mm pitch type 0.4A)	Operating temperature range	-55 °C to +85°C (Note 1)	Storage temperature range	-10°C to +50°C (Note 2)
	Voltage rating	50 V AC (0.4mm pitch type 40V AC)		Operating humidity range		Relative humidity 90% max. (No condensation)

Recommended FPC	Thickness = 0.3 ± 0.05mm gold plated (under 30 pos.), 0.3 ± 0.03mm gold plated (over 31 pos.)
-----------------	-----------------------------------------------------------------------------------------------

Item	Specification	Conditions
1. Insulation resistance	500 MΩ min.	100 V DC
2. Withstanding voltage	No flashover or insulation breakdown.	150 V AC /one minute, 120 V AC /one minute(0.4mm pitch type)
3. Contact resistance	50 mΩ max. 100 mΩ max(0.4mm pitch type). * Including FPC conductor resistance	1 mA
4. Durability (insertion/ withdrawal)	Contact resistance: 50 mΩ max. 100 mΩ max(0.4mm pitch type). No damage, cracks, or parts dislocation.	20 cycles
5. Vibration	No electrical discontinuity of 1μs or more. Contact resistance: 50 mΩ max. 100 mΩ max(0.4mm pitch type).	Frequency: 10 to 55 Hz, single amplitude of 0.75 mm, 10 cycles in each of the 3 directions.
6. Shock	No damage, cracks, or parts dislocation.	Acceleration of 981 m/s ² , 6 ms duration, sine half-wave waveform, 3 cycles in each of the 3 axis
7. Humidity (Steady state)	Contact resistance: 50 mΩ max. 100 mΩ max(0.4mm pitch type).	96 hours at 40°C and humidity of 90% to 95%.
8. Temperature cycle	Insulation resistance: 50 MΩ min. No damage, cracks, or parts dislocation.	Temperature : -55°C→+15°C to +35°C→+85°C→+15°C to +35°C Time : 30 → 2 to 3 → 30 → 2 to 3 (Minutes) 5 cycles
9. Resistance to soldering heat	No deformation of components affecting performance.	Reflow : At the recommended temperature profile Manual soldering: 350°C ± 10°C for 5 seconds

Note 1: Includes temperature rise caused by current flow.

Note 2: The term "storage" refers to products stored for long period of time prior to mounting and use. Operating Temperature Range and Humidity range covers non- conducting condition of installed connectors in storage, shipment or during transportation.

Materials

Part	Material	Finish	Remarks	
Insulator	FH33 series	PA	UL94V-0	
		Color:Beige		
	FH33J series	LCP		Color:Deep brown
		PPS		Color:Beige
	FH33M series	LCP		Color:Black
		PA		Color:Beige
	FH33MHJ series	LCP		Color:Deep brown
PPS		Color:Beige		
Contacts	Phosphor bronze	Gold flash plated	---	
Metalfittings		Pure tin reflow plated	---	

Ordering information

FH 33 M H J - 12 (6) S B - 1 SH (10)

① ② ③ ④ ⑤ ⑥ ⑦ ⑧ ⑨ ⑩ ⑪ ⑫

① Series name:FH	④ Blank:Width 3.0mm(standard) H:Width 3.5mm(long actuator type)	⑦ Standard type:Blank Eccentric type:Number of contacts	⑩ Contact pitch: 0.4mm,0.5mm,1mm
② Series No:33	⑤ Blank:Standard J:Halogen-free Flame retardance UL94V-0	⑧ Contact alignment:S: single ⑨ Eccentric direction: Blank:standard type B:Eccentric type	⑪ SH:SMT horizontal mounting ⑫ Plating specifications: Blank:Gold plated (10)...Gold plating with nickel barrier 5,000pieces/reel (99)...Gold plating with nickel barrier 500pieces/reel
③ Blank:0.5mm pitch,1mm pitch M:0.4mm pitch			

Connector Dimensions

●0.4mm pitch, 0.5mm pitch type

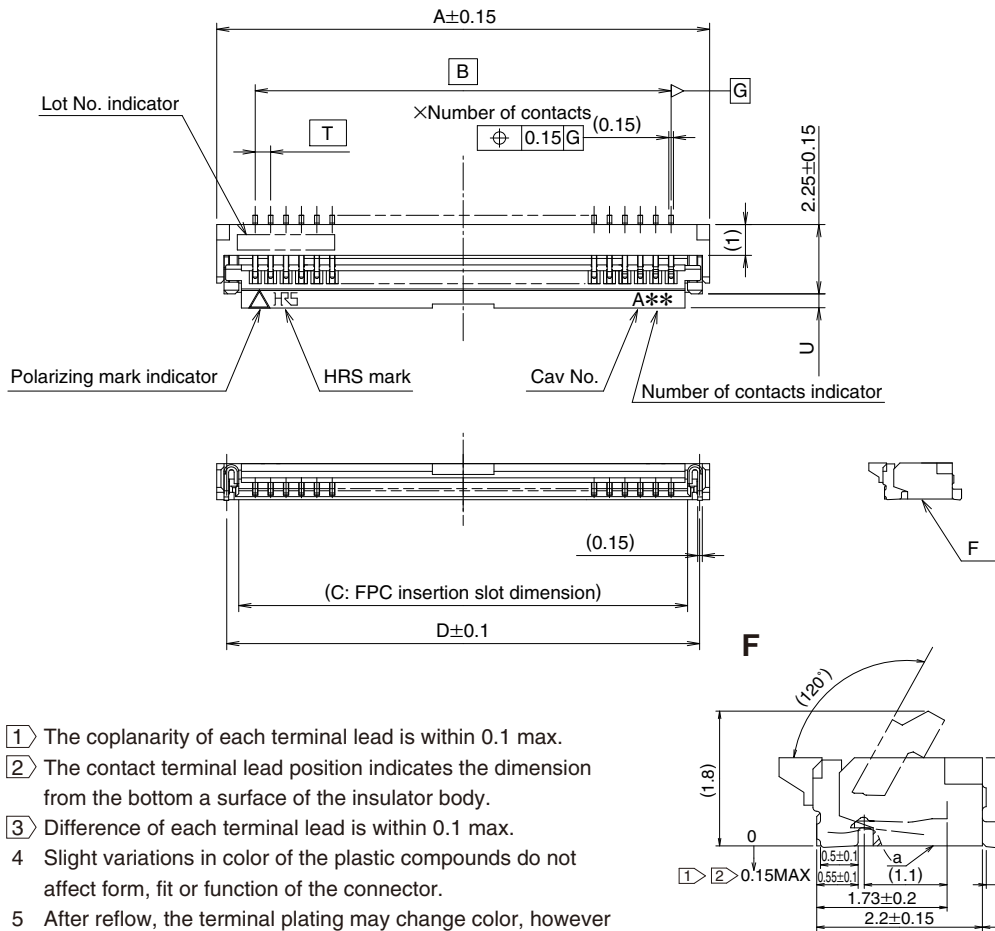

- Notes
- 1 The coplanarity of each terminal lead is within 0.1 max.
 - 2 The contact terminal lead position indicates the dimension from the bottom a surface of the insulator body.
 - 3 Difference of each terminal lead is within 0.1 max.
 - 4 Slight variations in color of the plastic compounds do not affect form, fit or function of the connector.
 - 5 After reflow, the terminal plating may change color, however this does not represent a quality issue.

Unit: mm

Part Number	CL No.	Number of Contacts	A	B	C	D	T	U
FH33-6S-0.5SH (**)	580-1301-1-**-	6	5	2.5	3.57	4.35	0.5	0.45
FH33-9S-0.5SH (**)	580-1303-7-**-	9	6.5	4	5.07	5.85	0.5	0.45
FH33-10S-0.5SH (**)	580-1304-0-**-	10	7	4.5	5.57	6.35	0.5	0.45
FH33-12S-0.5SH (**)	580-1302-4-**-	12	8	5.5	6.57	7.35	0.5	0.45
FH33-14S-0.5SH (**)	580-1305-2-**-	14	9	6.5	7.57	8.35	0.5	0.45
FH33-19S-0.5SH (**)	580-1307-8-**-	19	11.5	9	10.07	10.85	0.5	0.45
FH33-20S-0.5SH (**)	580-1317-1-**-	20	12	9.5	10.57	11.35	0.5	0.45
FH33-26S-0.5SH (**)	580-1306-5-**-	26	15	12.5	13.57	14.35	0.5	0.45
FH33-28S-0.5SH (**)	580-1300-9-**-	28	16	13.5	14.57	15.35	0.5	0.45
FH33-30S-0.5SH (**)	580-1312-8-**-	30	17	14.5	15.57	16.35	0.5	0.45
FH33-32S-0.5SH (**)	580-1310-2-**-	32	18	15.5	16.57	17.35	0.5	0.45
FH33-36S-0.5SH (**)	580-1311-5-**-	36	20	17.5	18.57	19.35	0.5	0.45
FH33-40S-0.5SH (**)	580-1308-0-**-	40	22	19.5	20.57	21.35	0.5	0.45
FH33-45S-0.5SH (**)	580-1316-9-**-	45	24.5	22	23.07	23.85	0.5	0.45
FH33M-16S-0.4SH (**)	580-1319-7-**-	16	8.3	6	6.87	7.65	0.4	0.45
FH33J-4S-0.5SH (**)	580-1329-0-**-	4	4	1.5	2.57	3.35	0.5	0.45
FH33J-10S-0.5SH (**)	580-1324-7-**-	10	7	4.5	5.57	6.35	0.5	0.45
FH33J-12S-0.5SH (**)	580-1328-8-**-	12	8	5.5	6.57	7.35	0.5	0.45
FH33J-16S-0.5SH (**)	580-1331-2-**-	16	10	7.5	8.57	9.35	0.5	0.45
FH33J-18S-0.5SH (**)	580-1334-0-**-	18	11	8.5	9.57	10.35	0.5	0.45
FH33J-19S-0.5SH (**)	580-1332-5-**-	19	11.5	9	10.07	10.85	0.5	0.45
FH33J-40S-0.5SH (**)	580-1330-0-**-	40	22	19.5	20.57	21.35	0.5	0.45
FH33MHJ-65S-0.4SH (**)	580-1325-0-**-	65	27.9	25.6	26.47	27.25	0.4	0.95

Note 1: Embossed reel packaging (5,000 pieces/reel, 500 pieces/reel).
Order by number of reels.

Connector Dimensions

●1mm pitch type

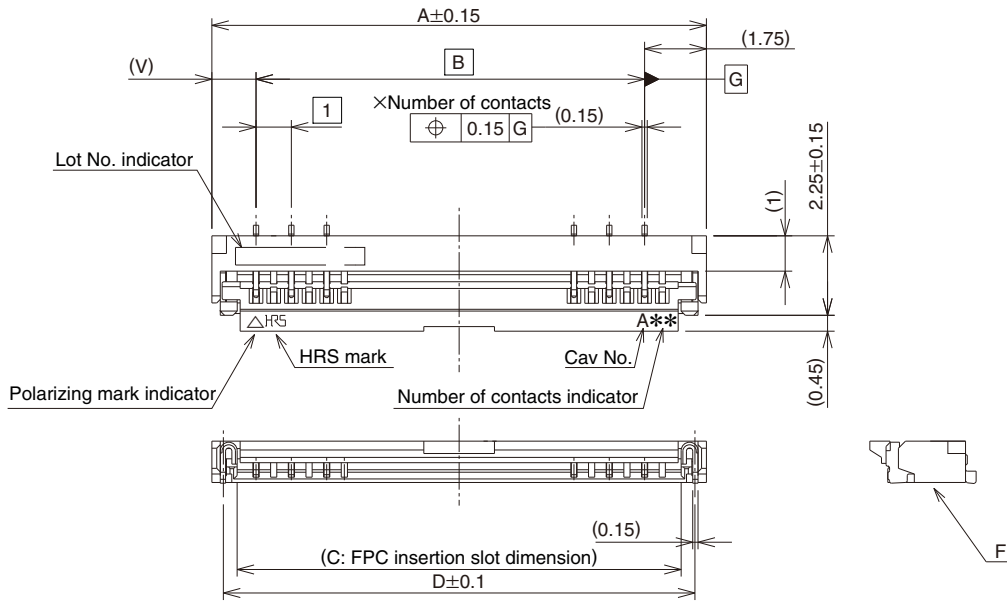

- Notes
- ① The coplanarity of each terminal lead is within 0.1 max.
 - ② The contact terminal lead position indicates the dimension from the bottom a surface of the insulator body.
 - ③ Difference of each terminal lead is within 0.1 max.
 - 4 Slight variations in color of the plastic compounds do not affect form, fit or function of the connector.
 - 5 After reflow, the terminal plating may change color, however this does not represent a quality issue.

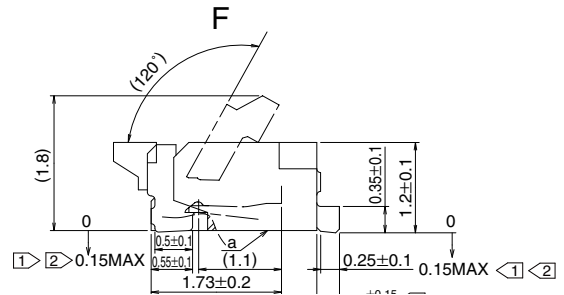

Unit: mm

Part Number	CL No.	Number of Contacts	A	B	C	D	V
FH33-4S-1SH(**)	580-1322-1-**-	4	6.5	3	5.07	5.85	1.75
FH33-12(6)SB-1SH(**)	580-1323-4-**-	6	8	5	6.57	7.35	1.25
FH33J-12(6)SB-1SH(**)	580-1326-2-**-	6	8	5	6.57	7.35	1.25

Note 1: Embossed reel packaging (5,000 pieces/reel, 500 pieces/reel).
Order by number of reels.

Recommended PCB mounting pattern and metal mask dimensions

1mm pitch type

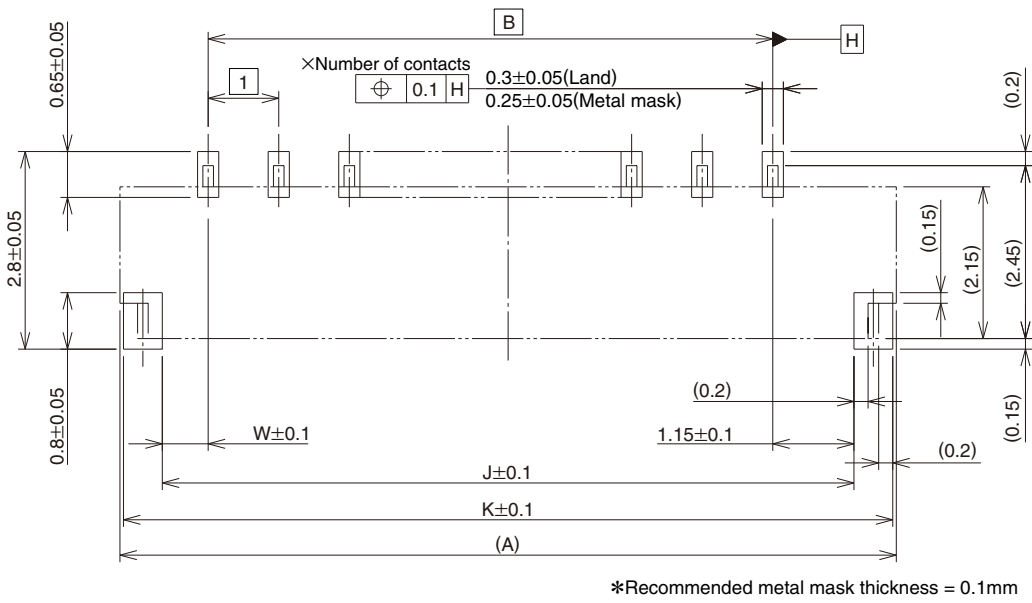

Recommended FPC/FFC dimensions

1mm pitch type

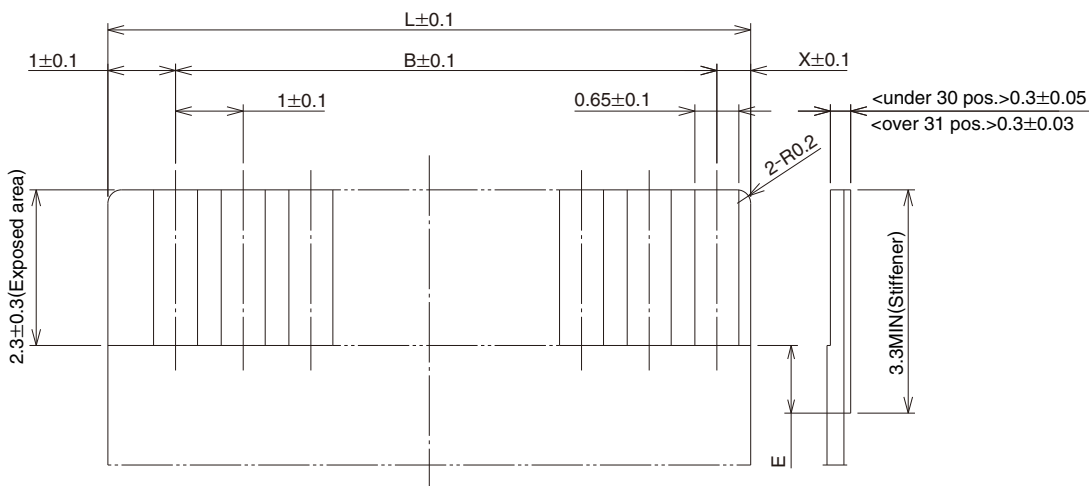

Unit: mm

Part Number	CL No.	Number of Contacts	A	B	J	K	L	W	X
FH33-4S-1SH(**)	580-1322-1-**-	4	6.5	3	5.3	6.4	5	1.15	1
FH33-12(6)SB-1SH(**)	580-1323-4-**-	6	8	5	6.8	7.9	6.5	0.65	0.5
FH33J-12(6)SB-1SH(**)	580-1326-2-**-	6	8	5	6.8	7.9	6.5	0.65	0.5

FH33 Series FPC/FFC Construction (Recommended Specifications)

1. Using Single-sided FPC

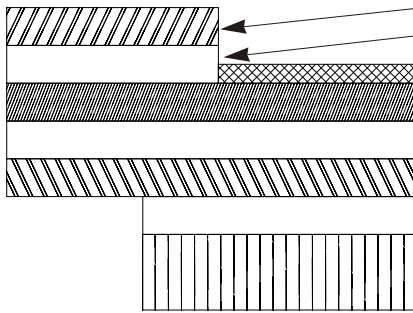

Material Name	Material	Thickness (μm)
Covering film layer	Polyimide 1 mil thick	(25)
Cover adhesive		(25)
Surface treatment	Nickel under plated 1 to 5μm / Gold plated 0.2μm	3
Copper foil	Cu 1oz	35
Base adhesive	Heat-hardened adhesive	25
Base film	Polyimide 1 mil thick	25
Reinforcement material adhesive	Heat-hardened adhesive	30
Stiffener	Polyimide 7 mil thick	175
Total		293

2. Using Double-sided FPC

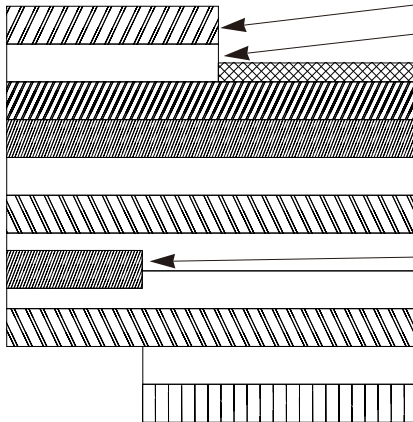

Material Name	Material	Thickness (μm)
Covering film layer	Polyimide 1 mil thick	(25)
Cover adhesive		(25)
Surface treatment	Nickel under plated 1 to 5μm / Gold plated 0.2μm	3
Through-hole copper	Cu	15
Copper foil	Cu 1/2oz	18
Base adhesive	Heat-hardened adhesive	18
Base film	Polyimide 1 mil thick	25
Base adhesive	Heat-hardened adhesive	18
Copper foil	Cu 1/2oz	18
Cover adhesive		25
Covering film layer	Polyimide 1 mil thick	25
Reinforcement material adhesive	Heat-hardened adhesive	50
Stiffener	Polyimide 4 mil thick	100
Total		297

3. Using FFC

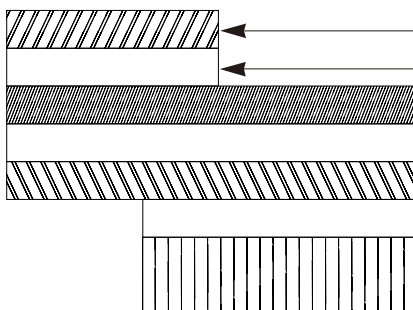

Material Name	Material	Thickness (μm)
Polyester film		(12)
Adhesive	polyester thermoplastic type	(30)
Gold plated, soft copper film		35
Adhesive	Polyester	30
Polyester		12
Adhesive	Polyester	30
Stiffener	Polyester	188
Total		295

※ Practical tolerance of thickness dimension is ±20 μm

4. Precautions

1. This specification is a recommendation for the construction of the FH33 Series FPC and FFC (t=0.3 ± 0.05).
2. For details about the construction, please contact the FPC/FFC manufacturers.

■ Packaging Specifications

● Embossed Carrier Tape Dimensions (Tape width up to 24mm)

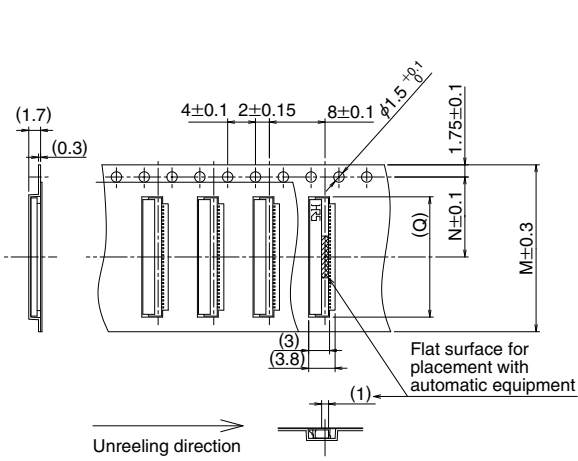

● Embossed Carrier Tape Dimensions (Tape width 32mm and over)

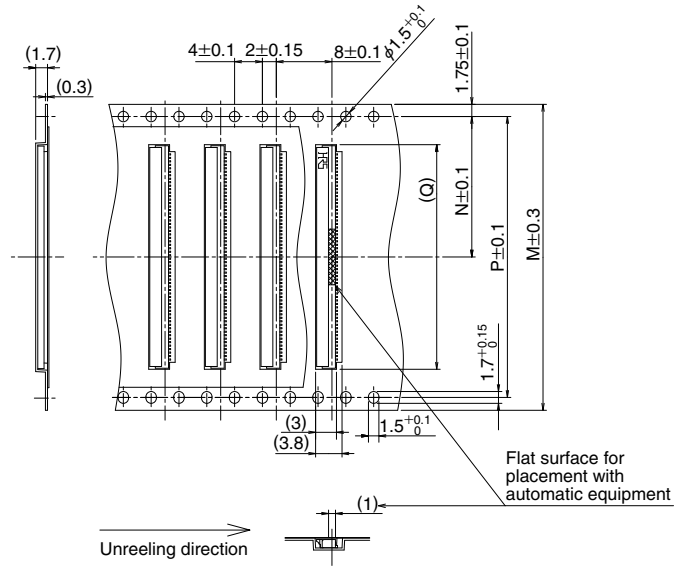

● Reel Dimensions

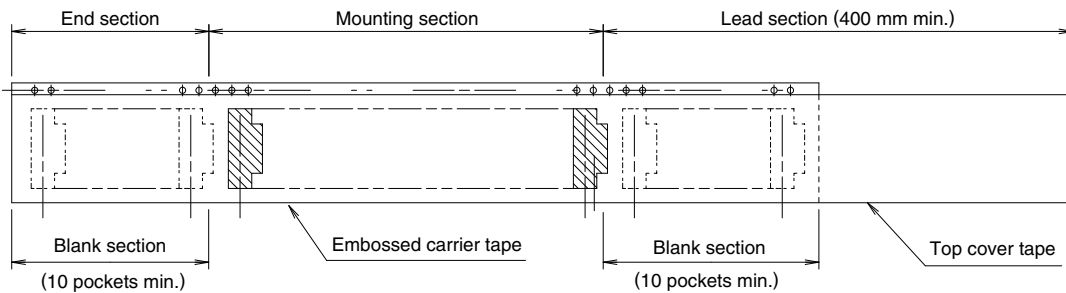
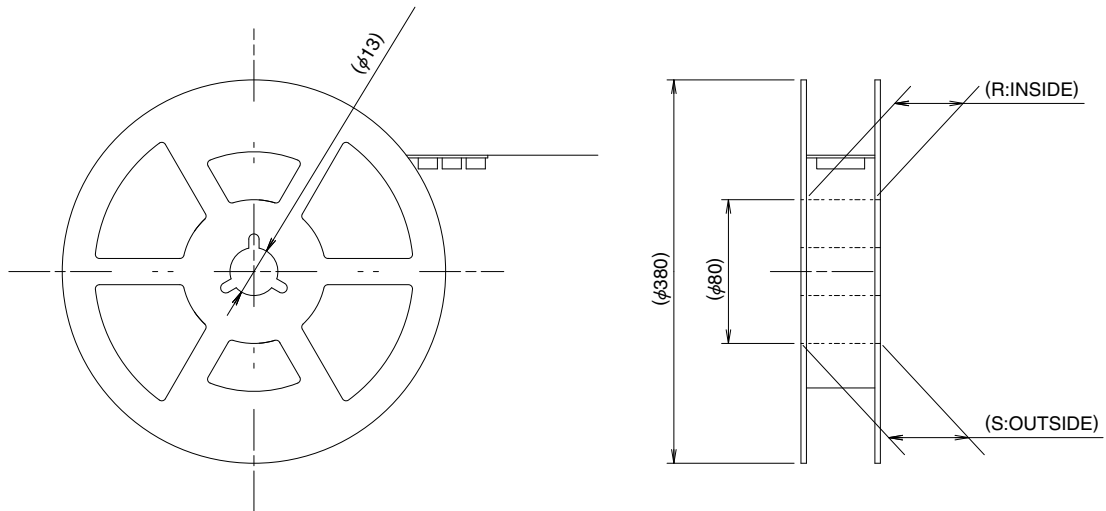

Note: 5,000 pieces per reel.

Embossed tape 32 mm or wider will have perforated feed holes on two sides.

Unit: mm

Part Number	CL No.	Number of Contacts	M	N	P	Q	R	S
FH33-6S-0.5SH (**)	580-1301-1-**-	6	16	7.5	—	5.3	17.4	21.4
FH33-9S-0.5SH (**)	580-1303-7-**-	9	16	7.5	—	6.8	17.4	21.4
FH33-10S-0.5SH (**)	580-1304-0-**-	10	16	7.5	—	7.3	17.4	21.4
FH33-12S-0.5SH (**)	580-1302-4-**-	12	16	7.5	—	8.3	17.4	21.4
FH33-14S-0.5SH (**)	580-1305-2-**-	14	16	7.5	—	9.3	17.4	21.4
FH33-19S-0.5SH (**)	580-1307-8-**-	19	24	11.5	—	11.8	25.4	29.4
FH33-20S-0.5SH (**)	580-1317-1-**-	20	24	11.5	—	12.3	25.4	29.4
FH33-26S-0.5SH (**)	580-1306-5-**-	26	24	11.5	—	15.3	25.4	29.4
FH33-28S-0.5SH (**)	580-1300-9-**-	28	24	11.5	—	16.3	25.4	29.4
FH33-30S-0.5SH (**)	580-1312-8-**-	30	24	11.5	—	17.3	25.4	29.4
FH33-32S-0.5SH (**)	580-1310-2-**-	32	32	14.2	28.4	18.3	33.4	37.4
FH33-36S-0.5SH (**)	580-1311-5-**-	36	32	14.2	28.4	20.3	33.4	37.4
FH33-40S-0.5SH (**)	580-1308-0-**-	40	44	20.2	40.4	22.3	45.4	49.4
FH33-45S-0.5SH (**)	580-1316-9-**-	45	44	20.2	40.4	24.8	45.4	49.4
FH33M-16S-0.4SH (**)	580-1319-7-**-	16	24	11.5	—	8.6	25.4	29.4
FH33J-4S-0.5SH (**)	580-1329-0-**-	4	16	7.5	—	4.3	17.4	21.4
FH33J-10S-0.5SH (**)	580-1324-7-**-	10	16	7.5	—	7.3	17.4	21.4
FH33J-12S-0.5SH (**)	580-1328-8-**-	12	16	7.5	—	8.3	17.4	21.4
FH33J-16S-0.5SH (**)	580-1331-2-**-	16	24	11.5	—	10.3	25.4	29.4
FH33J-18S-0.5SH (**)	580-1334-0-**-	18	24	11.5	—	11.3	25.4	29.4
FH33J-19S-0.5SH (**)	580-1332-5-**-	19	24	11.5	—	11.8	25.4	29.4
FH33J-40S-0.5SH (**)	580-1330-0-**-	40	44	20.2	40.4	22.3	45.4	49.4
FH33MHJ-65S-0.4SH (**)	580-1325-0-**-	65	44	20.2	40.4	28.2	45.4	49.4
FH33-4S-1SH (**)	580-1322-1-**-	4	16	7.5	—	6.8	17.4	21.4
FH33-12(6)S-1SH (**)	580-1323-4-**-	6	16	7.5	—	8.3	17.4	21.4
FH33J-12(6)S-1SH (**)	580-1326-2-**-	6	16	7.5	—	8.3	17.4	21.4

Jun.1.2024 Copyright 2024 HIROSE ELECTRIC CO., LTD. All Rights Reserved.

■Recommended Temperature Profile

●Using Lead-free Solder paste

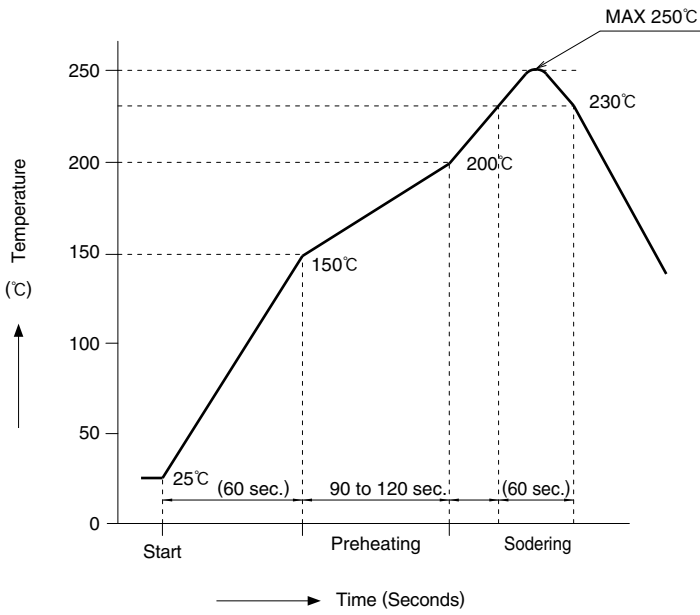

HRS test conditions

Solder method : Reflow, IR/hot air

Environment : Room air

Solder composition : Paste, 96.5%Sn/3.0%Ag/0.5%Cu
(Senju Metal Industry, Co., Ltd.'s Part Number: M705-221CM5-32-10.5)

Test board : Glass epoxy 25mm×50mm×0.8mm thick

Land dimensions : Contacts lead 0.3mm×0.65mm

Metal fittings 0.55mm×0.8mm

Metal mask : Contacts lead 0.25mm×0.65mm×0.1mm thick

Metal fittings 0.55mm×0.8mm×0.1mm thick

This temperature profile is based on the above conditions. In individual applications the actual temperature may vary, depending on solder paste type, volume/thickness and board size/thickness. Consult your solder paste and equipment manufacturer for specific recommendations.

■ Operation and Precautions

Operation

1. FPC insertion procedure. Connector installed on the board.

- 1 Lift up the actuator. Use thumb or index finger.

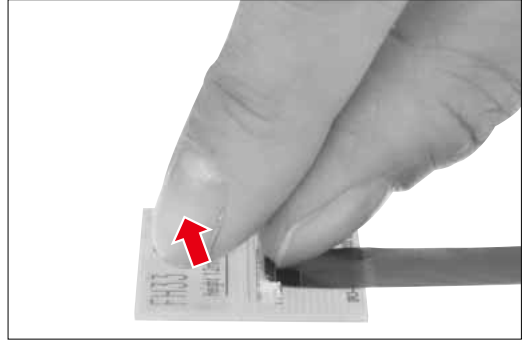

- 2 Fully insert the FPC in the connector parallel to mounting surface, with the exposed conductive traces facing down.

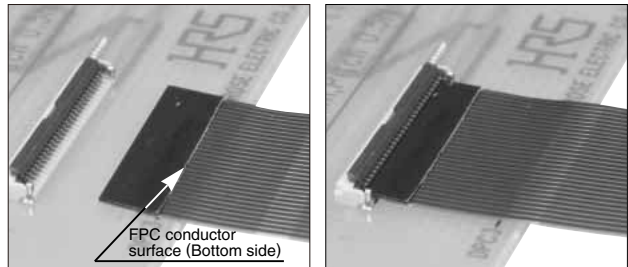

- 3 Rotate down the actuator until firmly closed. It is critical that the inserted FPC is not moved and remains fully inserted.



2. FPC removal

- 1 Lift up the actuator. Carefully withdraw the FPC.

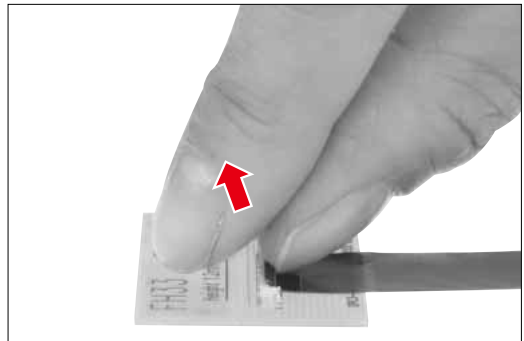

Precautions

Exercise care when handling connectors. Follow recommendations given below.

PC board flexing

- ◆PC board connector mounting area
The connectors are straight within 0.1 mm max.
Make sure that the PC board connector mounting area flatness can accept the connector terminals without causing any failure of the solder joints.
- ◆Handling before mounting on PCB
Insertion of the FPC or operation of the actuator prior to mounting on the PCB is NOT RECOMMENDED.
- ◆PC Board handling
Exercise caution when handling boards with the connectors installed. Do not apply any forces affecting soldered joints.

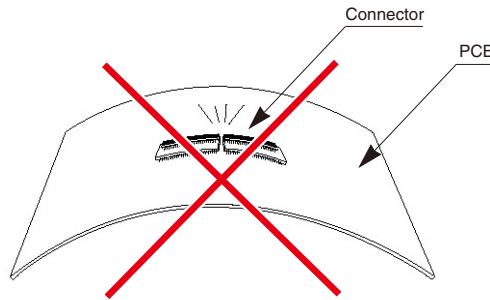

Precautions When Inserting or Removing FPC

Pay attention to the following points when inserting FPC.

- ◆Actuator operation
 - ① Do not apply excessive force when opening the actuator prior to FPC insertion. When opening make sure that the force is applied only to the actuator itself, avoiding touching of the contacts.

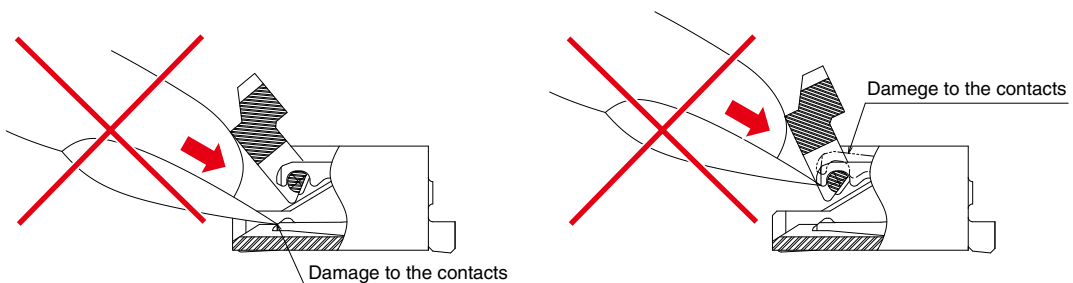

② Axis of rotation

Assure free rotation of the actuator

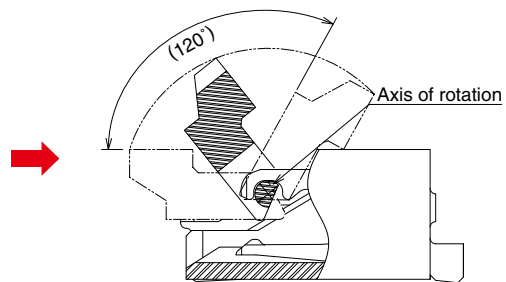

- ③ The actuator will rotate 120 degrees maximum. Do not force it to rotate further.

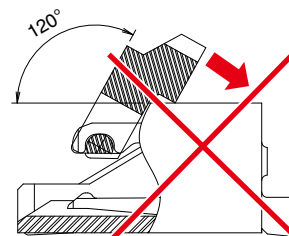

Precautions

④ When operating the actuator, do so at the center portion.

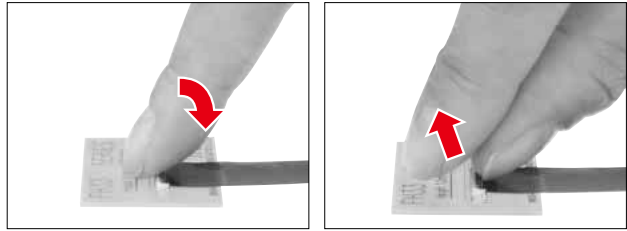

⑤ As illustrated, do not attempt removal or re-positioning of the actuator.

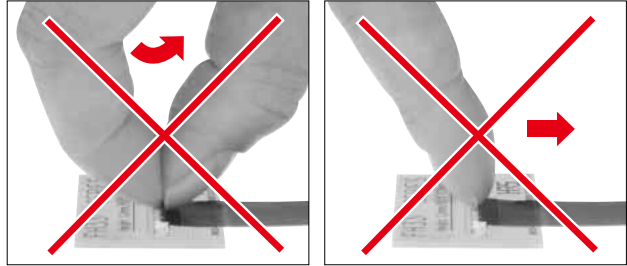

◆ FPC Insertion①

The FPC should be aligned parallel with the board surface and perpendicular with the connector (as shown), then completely inserted.

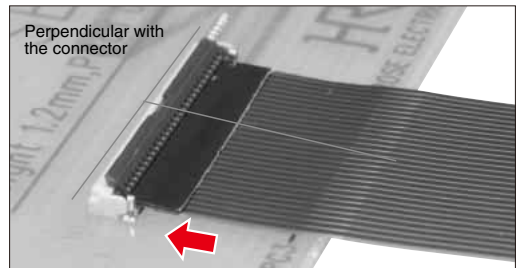
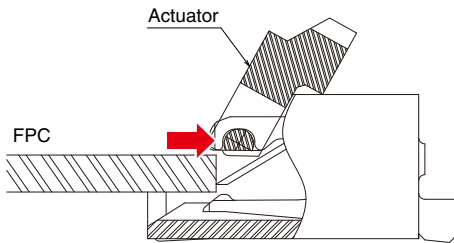

To assure correct electrical and mechanical connection do not insert FPC at angle. It must be fully inserted.

Make sure that the FPC is NOT MOVED during the closing of the actuator.

◆ FPC Insertion②

When inserting the FPC, do not forcefully rub against the bottom surface of the connector insertion entrance. Doing so will result in the contacts and FPC making strong contact and may cause deformation of the contacts, peeling of the FPC conductor, and other problems.

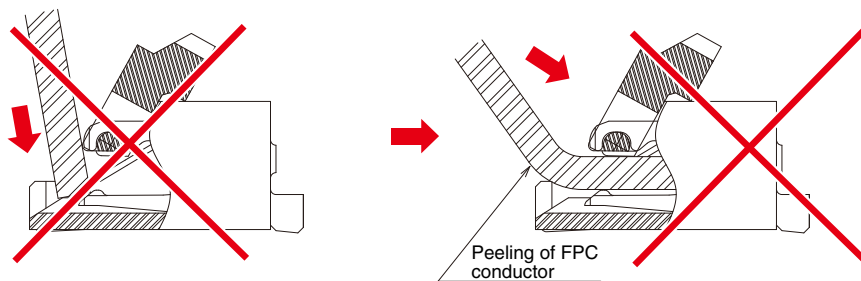

Precautions

◆ Verification of the fully closed actuator.

The actuator should be fully closed (as illustrated) and the FPC held firmly in the connector. Do not press against the actuator when is fully closed. Max force applied to the fully closed actuator should not exceed 1 N.

Routing the FPC (FPC fully inserted/ actuator closed)

◆ FPC Load

Do not apply force in excess of 0.15N max. in the upward direction (as illustrated). Do not bend the FPC too close to the actuator.

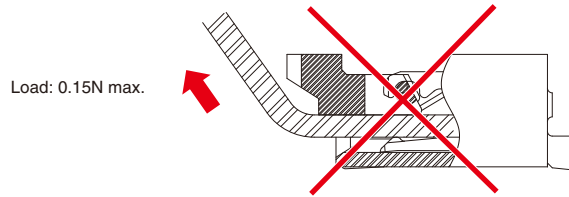

Removing the FPC

Rotate the actuator to the open position (maximum open angle of 120°). Carefully withdraw the FPC.

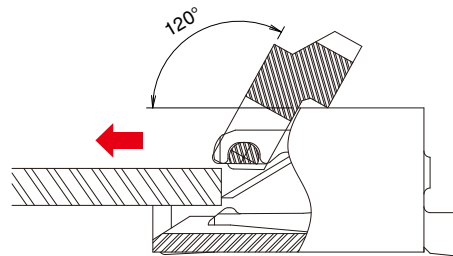
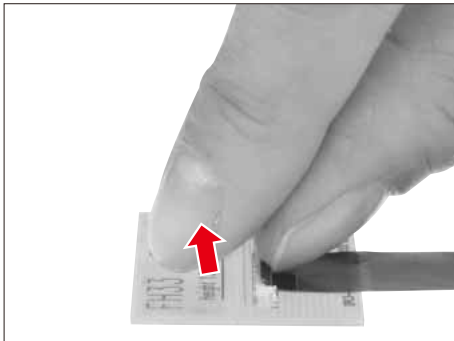

Other Precautions

◆ Hand Soldering Precautions

When hand soldering:

- ① Do not perform reflow or hand soldering with the FPC inserted in the connector.
- ② Do not apply excessive heat or touch the soldering iron anywhere other than the connector leads.
- ③ Do not use excessive amount of solder or flux compounds.

Operation of the actuator and contacts may be affected by excessive amounts of solder or flux compounds.

USA:

HIROSE ELECTRIC (U.S.A.), INC. Headquarters

2688 Westhills Court, Simi Valley, CA 93065-6235
 Phone : 1-805-522-7958
 Fax : 1-805-522-3217
<http://www.hiroseusa.com>

USA:

HIROSE ELECTRIC (U.S.A.), INC. North California Office

20400 Stevens Creek Blvd., Ste 250, Cupertino, CA 95014
 Phone : 1-408-253-9640
 Fax : 1-408-253-9641
<http://www.hiroseusa.com>

USA:

HIROSE ELECTRIC (U.S.A.), INC. Detroit Office (Automotive)

37677 Professional Center Drive, Suite #100C Livonia, MI 48154
 Phone : 1-734-542-9963
 Fax : 1-734-542-9964
<http://www.hiroseusa.com>

GERMANY:

HIROSE ELECTRIC EUROPE B.V. GERMAN BRANCH

Herzog-Carl-Strasse 4 D-73760 Ostfildern (Scharnhäuser Park)
 Phone : 49-711-4560-02-1
 Fax : 49-711-4560-02-299
<http://www.hirose.de>

THE NETHERLANDS:

HIROSE ELECTRIC EUROPE B.V.

Hogehillweg #8 1101 CC Amsterdam Z-O
 Phone : 31-20-6557460
 Fax : 31-20-6557469
<http://www.hiroseeurope.com>

UK:

HIROSE ELECTRIC EUROPE B.V. UK BRANCH

First Floor, St Andrews House, Caldecotte Lake Business Park, Milton Keynes MK7 8LE
 Phone : 44-1908-369060
 Fax : 44-1908-369078
<http://www.hirose.co.uk>

CHINA:

HIROSE ELECTRIC CO., LTD. BEIJING REPRESENTATIVE OFFICE

A1001, Ocean International Center, Building 56# East 4th Ring Middle Road, Chao Yang District, Beijing, 100025
 Phone : 86-10-5165-9332
 Fax : 86-10-5908-1381
<http://www.hirose-china.com.cn>

CHINA:

HIROSE ELECTRIC (SHANGHAI) CO., LTD.

1501-02, Cross Tower Building, 318 Fuzhou Road, Huang Pu District, Shanghai 200001
 Phone : 86-21-6391-3355
 Fax : 86-21-6335-0767
<http://www.hirose-china.com.cn>

CHINA:

HIROSE ELECTRIC CO., LTD. SHENZHEN OFFICE

Room 09-13, 19/F, Office Tower Shun Hing Square, Di Wang Commercial Centre 5002, ShenNanDong Road, ShenZhen City, Guangdong Province, 518008
 Phone : 86-755-8207-0851
 Fax : 86-755-8207-0873
<http://www.hirose-china.com.cn>

HONG KONG:

HIROSE ELECTRIC HONGKONG TRADING CO., LTD.

Unit 1102 A&B, Energy Plaza, 92 Granville Road, Tsim Sha Tsui East, Kowloon
 Phone : 852-2803-5338
 Fax : 852-2591-6560
<http://www.hirose-hongkong.com.hk>

TAIWAN:

HIROSE ELECTRIC TAIWAN CO., LTD.

103 8F, No.87, Zhengzhou Rd., Taipei
 Phone : 886-2-2555-7377
 Fax : 886-2-2555-7350
<http://www.hirose-taiwan.com.tw>

SINGAPORE:

HIROSE ELECTRIC CO., LTD.

10 Anson Road #26-16 International Plaza 079903
 Phone : 65-6324-6113
 Fax : 65-6324-6123
<http://www.hirose-singapore.com.sg>

KOREA:

HIROSE KOREA CO., LTD.

1261-10, Jeoungwhang-Dong, Shihung-City, Kyunggi-Do 429-450
 Phone : 82-31-496-7000,7124
 Fax : 82-31-496-7100
<http://www.hirose.co.kr>

Jun.1.2024 Copyright 2024 HIROSE ELECTRIC CO., LTD. All Rights Reserved.



HIROSE ELECTRIC CO.,LTD.

6-3,Nakagawa Chuoh-2-Chome,Tsuzuki-Ku,Yokohama-Shi 224-8540,JAPAN
 TEL: +81-45-620-3526 Fax: +81-45-591-3726
<http://www.hirose.com>
<http://www.hirose-connectors.com>

Looking for pricing, stock, or lifecycle information?

Click below to explore more details on WIN SOURCE:

- [View FH33-12S-0.5SH\(10\) on WIN SOURCE](#)
- [Hirose Electric Co Ltd Information](#)

Optimize Your Supply Chain with WIN SOURCE Solutions

- ✓ Global Sourcing Solution
- ✓ Obsolete Management
- ✓ Cost Control Management
- ✓ Shortage Management
- ✓ Alternative Solution
- ✓ Excess Inventory Management