

Specifications

Drawing No.	USY1N-H1-14429-00 1 / 9
Issued Date.	Dec,3,2014

Messrs: Digi-Key

Note: Part Number will be revised in case of specification change.

Product Type	Tuning Fork Crystal
Series	ST3215SB
Frequency	32.768 kHz
Customer Part Number	-
Customer Specification Number	-
KYOCERA Part Number	ST3215SB32768H5HSZA1(CL=12.5pF) ST3215SB32768E0HSZB1(CL=9.0pF) ST3215SB32768C0HSZA1(CL=7.0pF) ST3215SB32768B0HSZA1(CL=6.0pF)
Remarks	Pb-Free, RoHS Compliant, MSL 1 AEC Q200 conformity.

Customer Approval

Approval Signature	Approved Date	
	Department	
	Person in charge	

Seller

KYOCERA Crystal Device Corporation
(Sales Division)
6 Takeda Tobadono-cho, Fushimi-ku, Kyoto
612-8501 Japan
TEL. No. 075-604-3500
FAX. No. 075-604-3501

Manufacturer

KYOCERA Crystal Device Corporation
(Crystal Units Division)
5850, Higashine-Koh, Higashine-Shi, Yamagata
999-3701 Japan
TEL. No. 0237-43-5611
FAX. No. 0237-43-5615

Design Department	Quality Assurance	Approved by	Checked by	Issued by
KYOCERA Crystal Device Corporation Crystal Unit Application Engineering Section Crystal Units Division	F.Mukae	T.Soda	A.Muraoka	Y.Nozaki

Revision History

Rev.No.	Description of revision	Date	Approved by	Checked by	Issued by
0	First Edition	Dec,3,2014	T.Soda	A.Muraoka	Y.Nozaki

1. APPLICATION

This specification sheet is applied to tuning fork crystal “ST3215SB” for Automotive(Non-Safety Application).

2. PART NUMBER

ST3215SB32768H5HSZA1(CL=12.5pF)

ST3215SB32768E0HSZB1(CL=9.0pF)

ST3215SB32768C0HSZA1(CL=7.0pF)

ST3215SB32768B0HSZA1(CL=6.0pF)

3. RATINGS

Items	SYMB.	Rating	Unit
Operating Temperature range	Topr	-40~+125	deg. C
Storage Temperature range	Tstg	-55~+125	deg. C

4. CHARACTERISTICS

4-1 ELECTRICAL CHARACTERISTICS

Item	Symbol	Electrical Specification				
		Condition	Min	Typ.	Max	Unit
Nominal Frequency	fo	Ta = 25 deg. C		32.768		kHz
Frequency Tolerance	df/fo	Ta = 25 deg.C	-20		20	ppm
Load Capacitance	CL			12.5 9.0 7.0 6.0		pF
Equivalent series resistance	R1				70	kΩ
Q-Value	Q		13000			
Motional capacitance	C1		3.0		4.4	fF
Shunt capacitance	Co		0.6		1.2	pF
Tuning point	Tp		20		30	deg. C
Secondary temperature Coefficient	K		-4.0			10 ⁻⁸ /degC ²
Aging	df/F	Ta = 25 deg. C	-3		3	ppm/year
Drive level	DL			0.1	0.5	μW
Insulation resistance (between electrodes)	IR		500			MΩ

4-2 MOISTURE SENSITIVITY LEVEL

Level 1

5. APPEARANCES, DIMENSIONS
OUTLINE DIMENSIONS (not to scale)

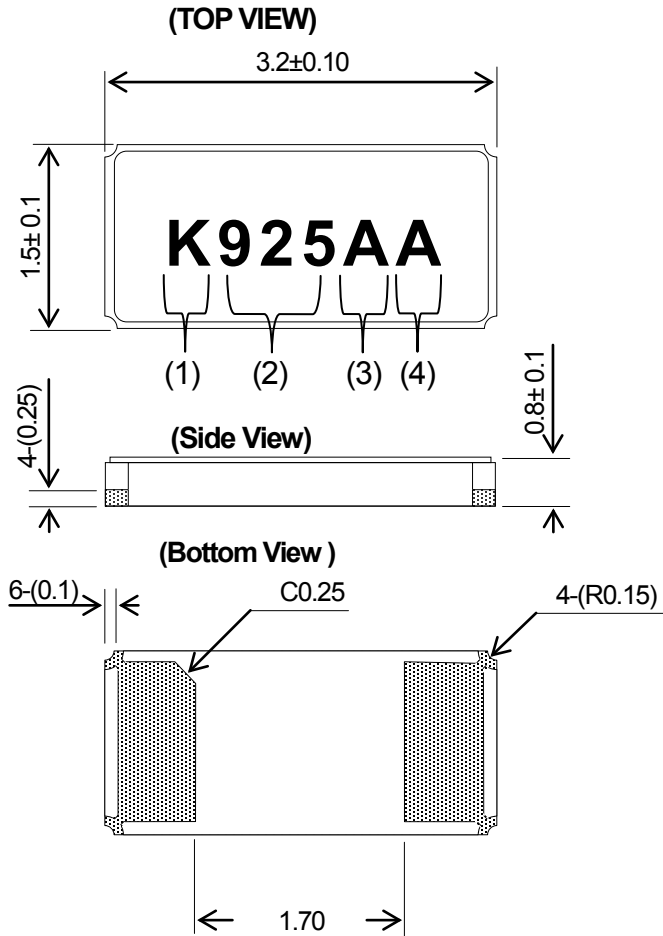

CONNECTION (TOP VIEW)

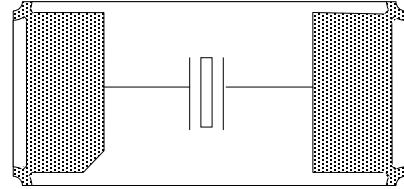

UNIT : mm

MARKING

- | | |
|-------------------------|---|
| (1) Identification | K |
| (2) Date Code(3 Digits) | Last 1 digit of year and week Code. |
| (3) Load Capacitance | (Example) 12.5pF → A
9.0pF → B
7.0pF → C
6.0pF → F |
| (4) Management number | Alphabet or Number 1digit. |

*The font of marking above is for reference purpose.

6. RECOMMENDED LAND PATTERN

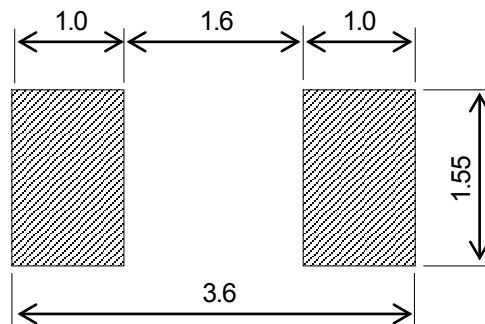

UNIT : mm

7. TAPING

7.1 Specification

1. Material of the carrier tape is either polystyrene or A-PET (ESD).
2. Material of the cover tape is polyester (ESD).
3. The seal tape shall not cover the sprocket holes and not protrude from the carrier tape.
4. The R of the corner of each cavity is 0.2R MAX.
5. The alignment between centers of the cavities and sprocket holes is 0.05mm or less.
6. The orientation shall be checked from the top cover tape side.
7. Peeling force of the cover tape: 0.1 to 0.7N.

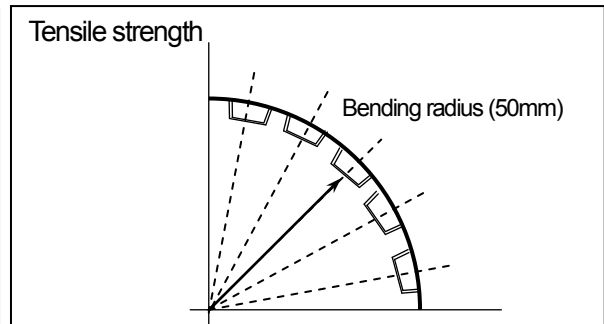
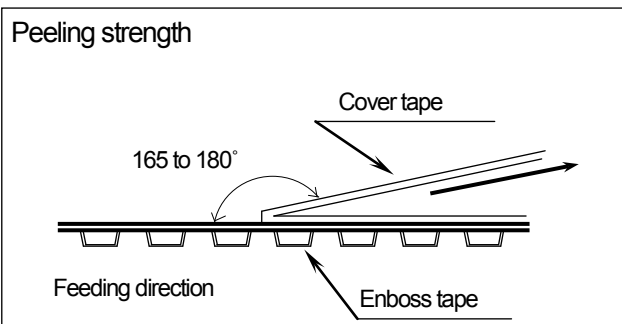
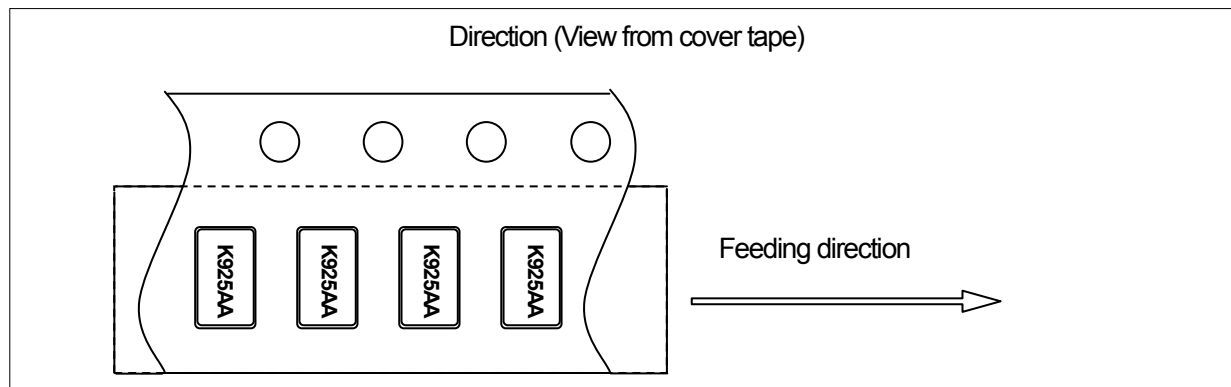
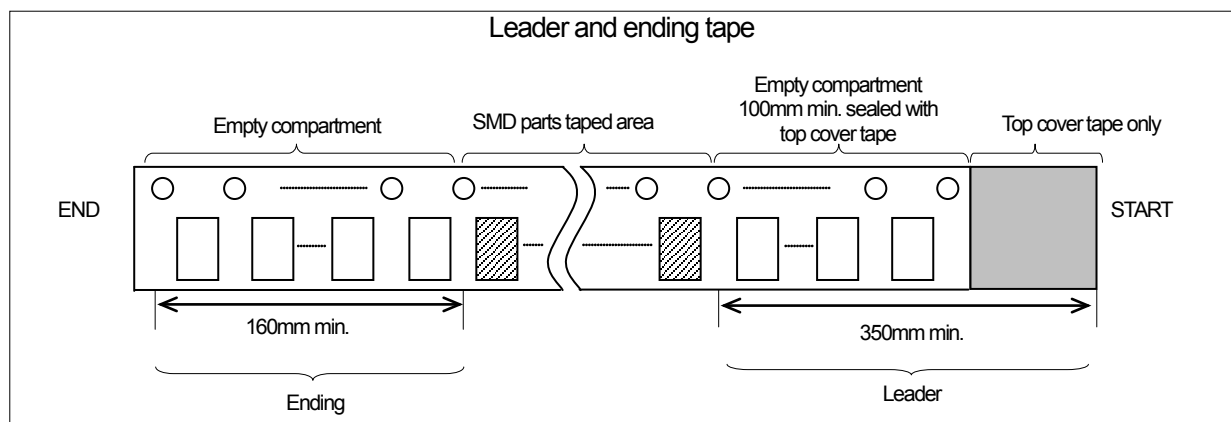

7-2 Carrier tape specifications

(Unit: mm)

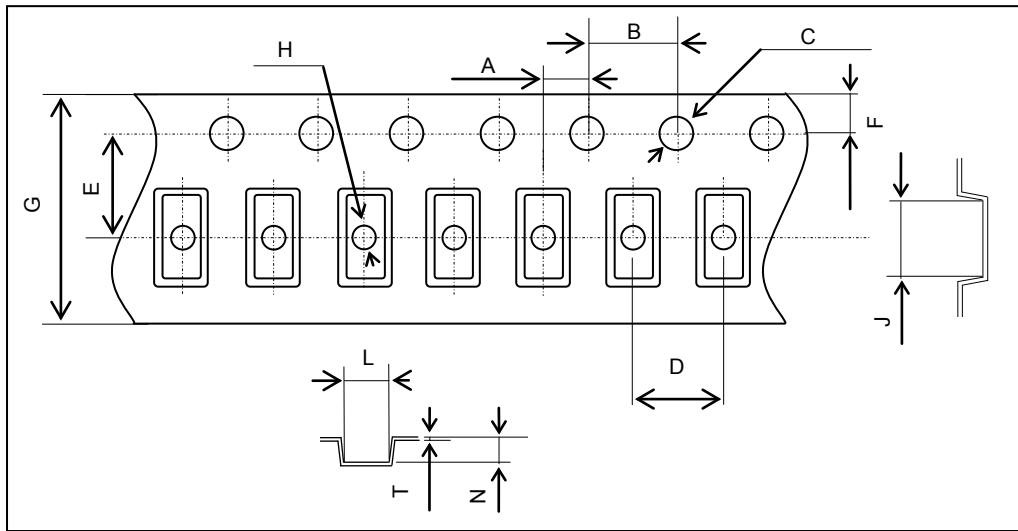

Symbol	A	B	C	D	E	F
Dimension	2.0±0.1	4.0±0.1	1.5+0.1/-0	4.0±0.1	5.5±0.1	1.75±0.1
Symbol	G	H	J	L	N	T
Dimension	12.0±0.3	1.0+0.1/-0	3.6±0.1	1.8±0.1	1.0±0.1	0.3±0.05

7-3 Reel specifications

(Unit: mm)

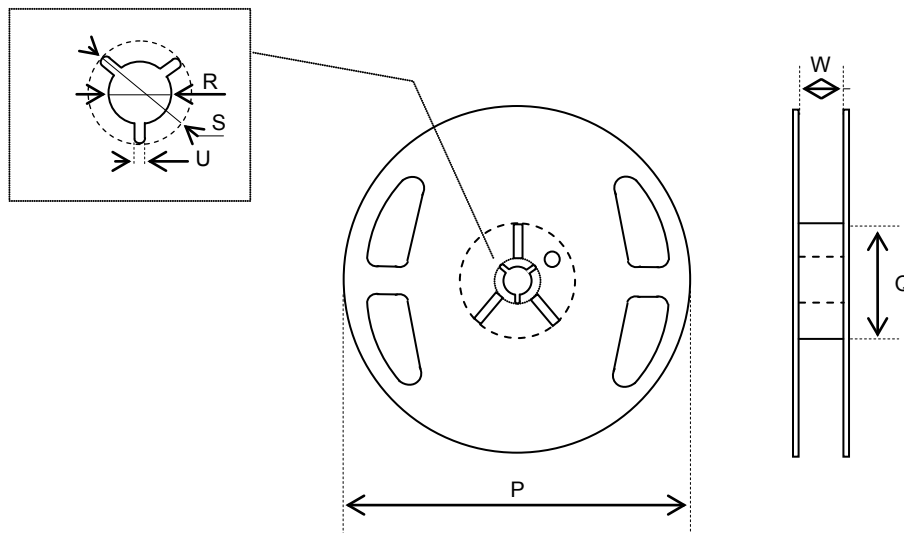

In the case of $\phi 180$ Reel

Symbol	P	Q	R
Dimension	$\phi 180 +0/-1.5$	$\phi 60 +1.0/-0$	$\phi 13 \pm 0.2$
Symbol	S	U	W
Dimension	$\phi 21 \pm 0.8$	2.0±0.5	13.0 +1.0/-0

8. RELIABILITY

(Reference: AEC-Q200 Rev. D. The solder used by examination is hereafter set to Sn-3Ag-0.5Cu.)

Frequency Stability and ESR Stability After stressing.

No	Stress	Reference	Additional Requirements
8.1	High Temperature Exposure (Storage)	MIL-STD-202 Method 108	1000 hrs. at rated operating temperature (e.g. 85°C part can be stored for 1000 hrs at 85°C. Same applies for 125°C). Unpowered. Measurement at 24±4 hours after test conclusion.
8.2	Temperature Cycling	JESD22 Method JA-104	1000 cycles (-55°C to 125°C) Note: If -40°C, 85°C part the 1000 cycles will be at that temperature rating. Measurement at 24±4 hours after test conclusion. 30min maximum dwell time at each temperature extreme. 1 min. maximum transition time.
8.3	Biased Humidity	MIL-STD-202 Method 103	1000 hours 85°C/85%RH. Rated VDD applied with 1 MW and inverter in parallel, 2X crystal CL capacitors between each crystal leg and GND. Measurement at 24±4 hours after test conclusion.
8.4	Operational Life	MIL-STD-202 Method 108	Note: 1000 hrs @ 125°C. If 85°C part will be tested at that temperature. Rated VDD applied with 1 MW and inverter in parallel, 2X crystal CL capacitors between each crystal leg and GND. Measurement at 24±4 hours after test conclusion.
8.5	Terminal Strength (Leaded)	MIL-STD-202 Method 211	Test leaded device lead integrity only. Conditions: A (227 g), C (227 g).
8.6	Resistance to Solvents	MIL-STD-202 Method 215	Note: Also aqueous wash chemical - OKEM clean or equivalent. Do not use banned solvents.
8.7	Mechanical Shock	MIL-STD-202 Method 213	Figure 1 of Method 213. Condition C
8.8	Vibration	MIL-STD-202 Method 204	5g's for 20 minutes 12 cycles each of 3 orientations. Note: Use 8"X5" PCB .031" thick with 7 secure points on one 8" side and 2 secure points on corners of opposite sides. Parts mounted within 2" from any secure point. Test from 10-2000 Hz.
8.9	Resistance to Soldering Heat	MIL-STD-202 Method 210	Condition B No pre-heat of samples. Note: Single Wave solder - Procedure 1 with solder within 1.5 mm of device body for Leaded. Procedure 1 except 230°C and immerse only to level to cover terminals for SMD.
8.10	Solderability	J-STD-002	For both Leaded & SMD. Electrical Test not required. Magnification 50 X. Conditions: Leaded: Method A @ 235°C, category 3. SMD: a) Method B, 4 hrs @ 155°C dry heat @ 235°C b) Method B @ 215°C category 3. c) Method D category 3 @ 260°C.
8.11	Flammability	UL-94	V-0 or V-1 Acceptable
8.12	Board Flex	AEC Q200-005	60 sec minimum holding time.
8.13	Terminal Strength(SMD)	AEC Q200-006	The static load of 1.8Kg is added in the direction of the arrow and it maintains it in the prime fields of parts for 60 sec with a scratch treatment device of R0.5.

9. REFLOW PROFILE

Pb-free reflow requirements for soldering heat resistance

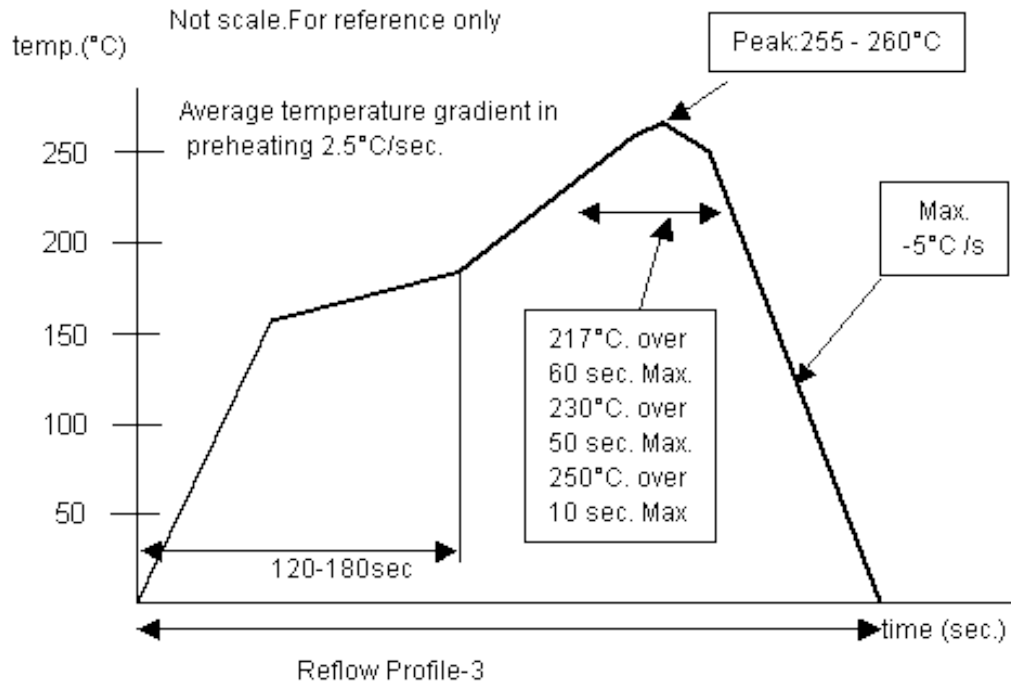

10. Cautions for use

(1) Soldering upon mounting

Characteristics may be affected when Solder paste or conductive glue comes in contact with product lid or surface.

(2) When using mounting machine

Please minimize the shock when using mounting machine to avoid any excess stress to the product.

(3) Conformity of a circuit

We strongly recommend to make sure that Negative resistance (Gain) of IC is designed to be 3 times the ESR (Equivalent Series Resistance) of Crystal unit.

11. Storage conditions

Please store product in below conditions, and use within 6 months.

Temperature +18 to +30°C, and Humidity of 20 to 70 % in the packaging condition.

12. Manufacturing location

Kyocera Crystal Device Corporation Shiga Yohkaichi Plant

13. Quality Assurance

To be guaranteed by Kyocera Crystal Device Quality Assurance Division

14. Quality guarantee



When Kyocera Crystal Device Corporation rooted failure occurs within 1 year after its delivery, substitute product will be arranged based on discussion. Quality guarantee of product after 1 year of its delivery will be waived.

15. Others



In case of any questions or opinions regarding the Specification, please have it in written manner within 45 days after issued date.

Looking for pricing, stock, or lifecycle information?

Click below to explore more details on WIN SOURCE:

-  [View ST3215SB32768E0HSZB1 on WIN SOURCE](#)
-  [AVX Corp/Kyocera Corp Information](#)

Optimize Your Supply Chain with WIN SOURCE Solutions

-  Global Sourcing Solution
-  Obsolete Management
-  Cost Control Management
-  Shortage Management
-  Alternative Solution
-  Excess Inventory Management