

NEW

Thunderbolt Compatible Connector DP3 Series

CONNECTOR

MB-0248-2

July 2013

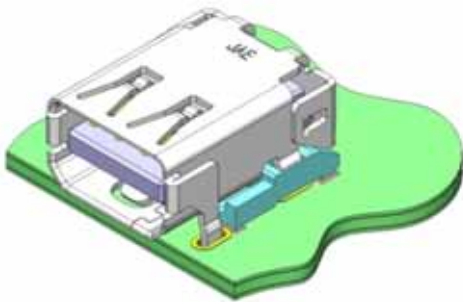
RoHS Compliant

On-board Standard

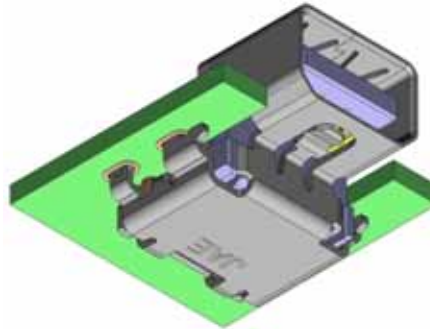

Reverse Sunk-into-the-board

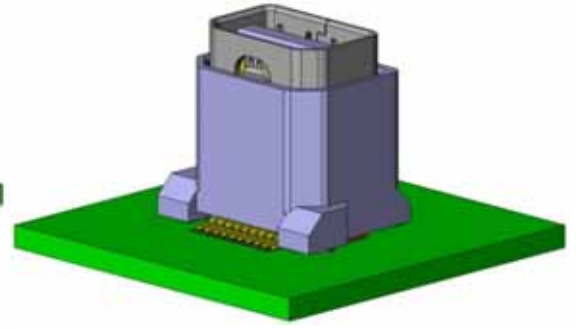

Straight

The DP3 Series has been developed as an I/O connector compatible with Thunderbolt™ Technology for high-speed transmission between PCs and peripheral devices.

*Thunderbolt is a trademark of Intel Corporation in the US and other countries.

Features

- 10Gbps per lane high-speed transmission connector for Thunderbolt.
- Available in standard and reverse mounting, sunk-into-the-board, and straight mounting type. JAE has additionally developed the straight mounting type.
- Enhanced board mounting strength with through-hole hold-downs on the metal shell.
- Friction lock with the metal shell enhances cable plug retention strength and creates a clear click feeling when mated.
- Connector is supplied in embossed reel.

General Information

No. of Contacts: 20

Contact Resistance: 100m Ω max.

Dielectric Withstanding Voltage:
AC300Vr.m.s for 1 minuteOperating Temperature:
-20 Deg. C to +85 Deg. C

Rated Current: 0.5A (signal pin)

Insulation Resistance: 10MΩ min.

Durability: 10,000 mating cycles

Materials and Finishes

Component	Material / Finish
Contact	Copper alloy / 0.3μ min. Au plating over Ni (contact area) Sn plating over Ni (terminal area)
Housing	Glass filled LCP / None
Shell	Stainless steel / Ni

Ordering Information

(On-board, Sunk-into-board)

DP3 AR 0 20 S U32 J Q 1 R****

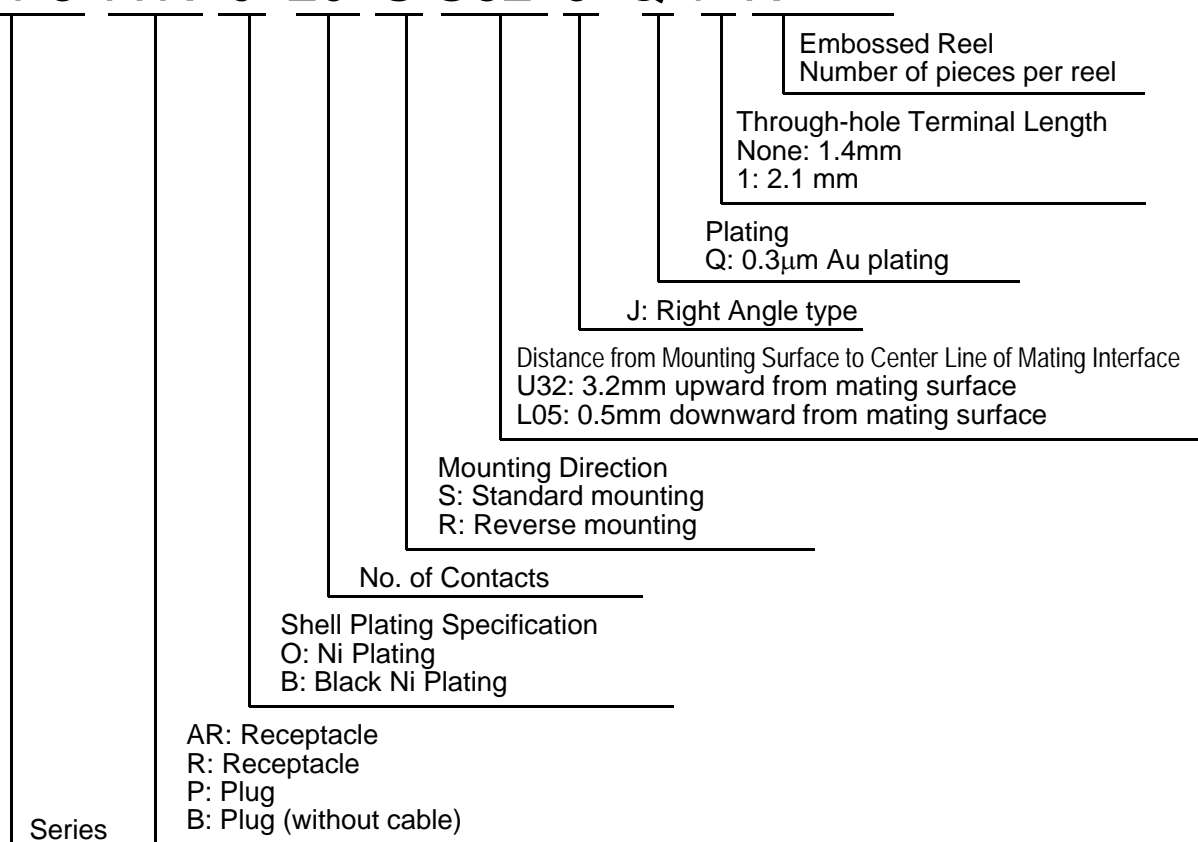

(Straight)

DP3 AR 0 20 W Q 1 R****

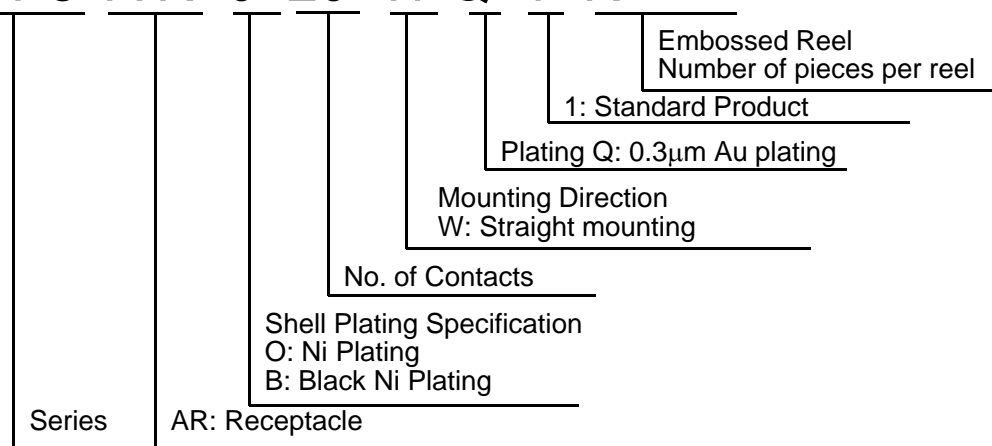

Part Number	SJ Drawing No.
DP3AR020SU32JQ1 (Individual Connector)	SJ113423
DP3AR020SU32JQ1R400 (Embossed Reel)	SJ113424

On-board
Standard Type

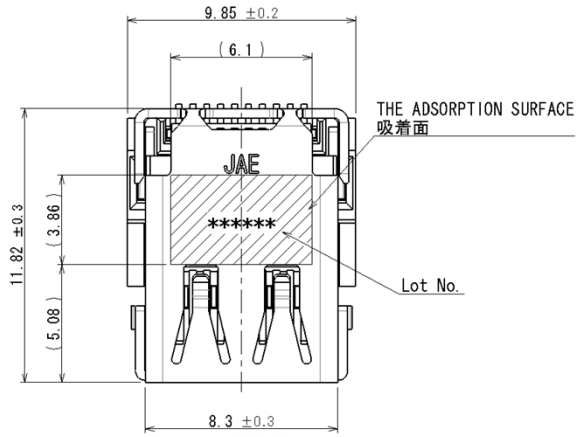

Unit: mm

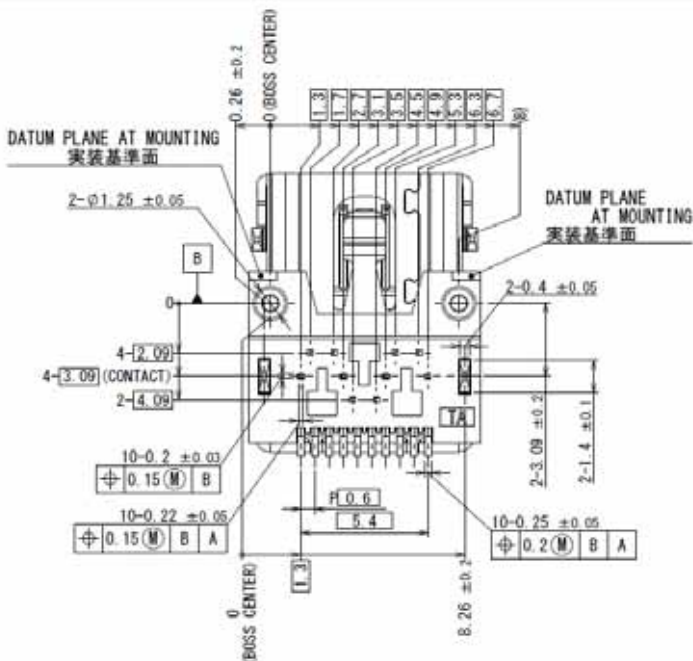
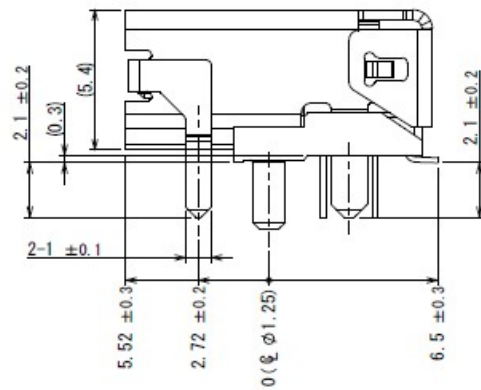
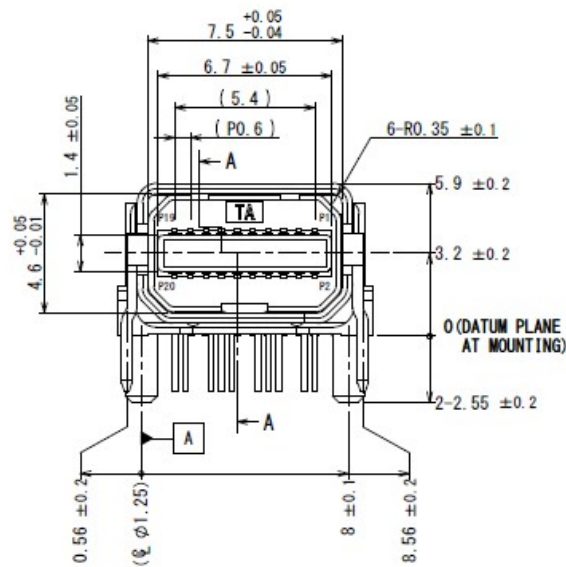

Part Number	SJ Drawing No.
DP3RB20RU05JQ (Individual Connector)	SJ112304
DP3RB20RU05JQR400 (Embossed Reel)	SJ112336

Sunk-into-the-board
Reverse Type

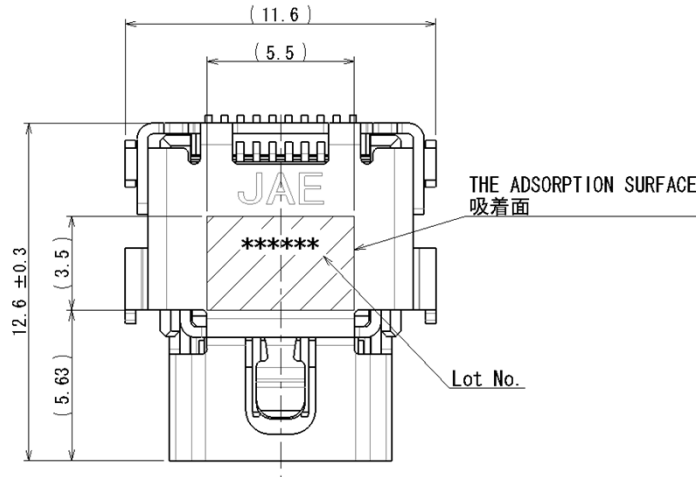

Unit: mm

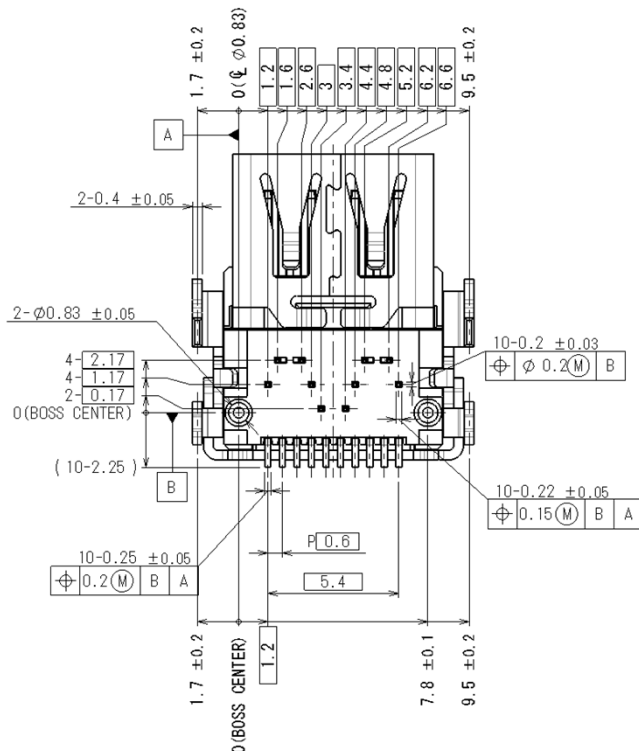
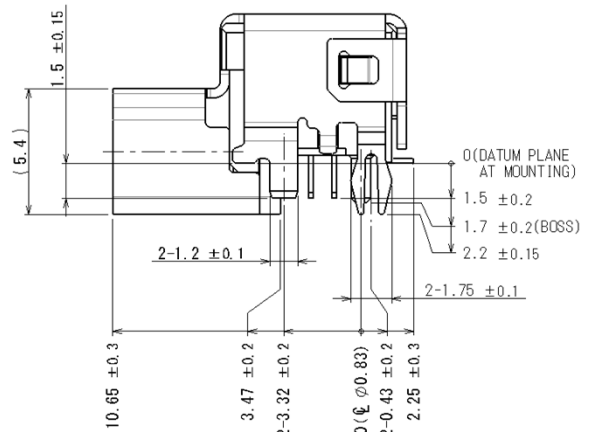
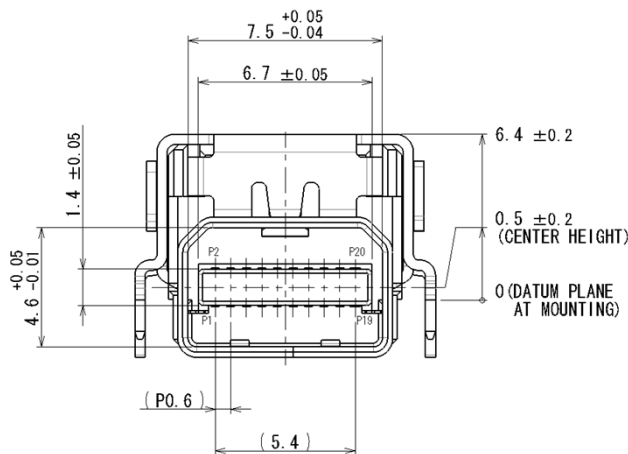

Part Number	SJ Drawing No.
DP3R020RL30JQ (Individual Connector)	SJ112303
DP3R020RL30JQR400 (Embossed Reel)	SJ112335

Sunk-into-the-board
Reverse Type

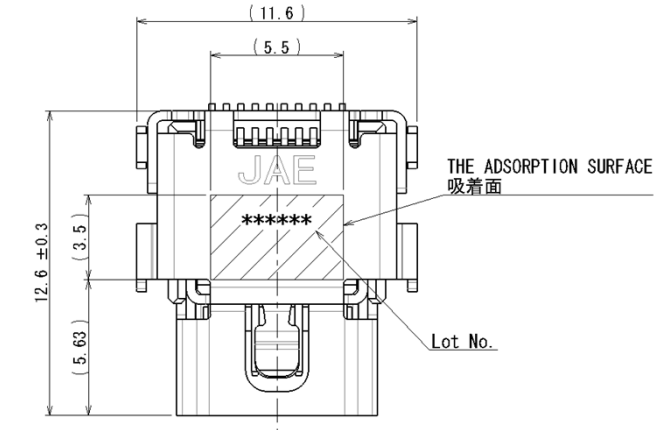

Unit: mm

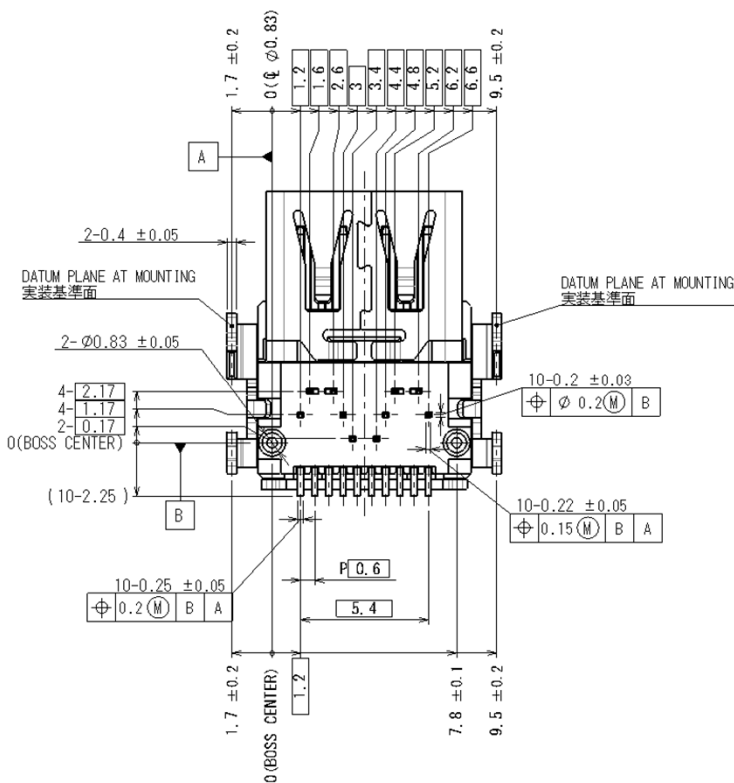
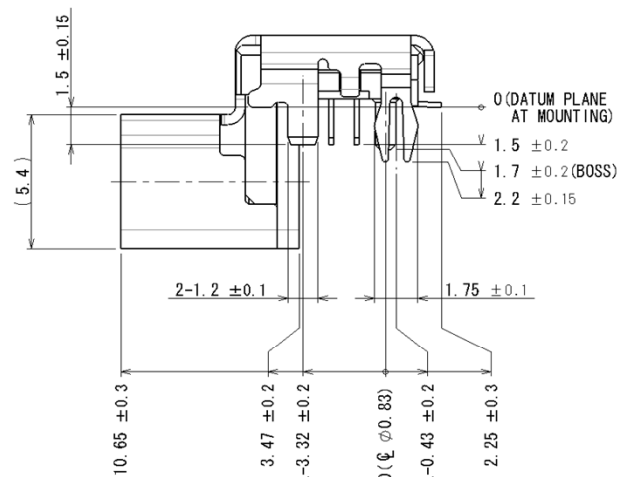
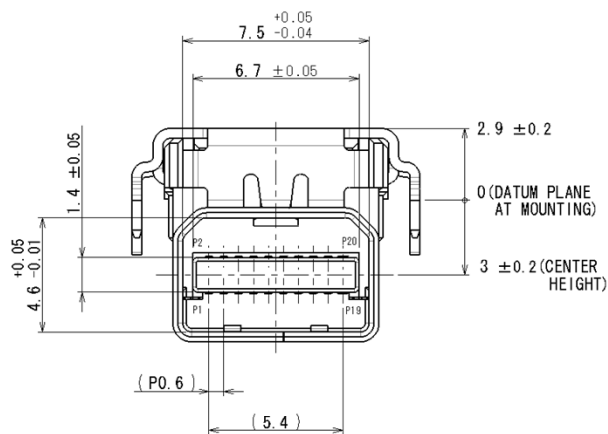

Applicable Dimensions of Board

REF: On-board,
Standard Type

Unit: mm

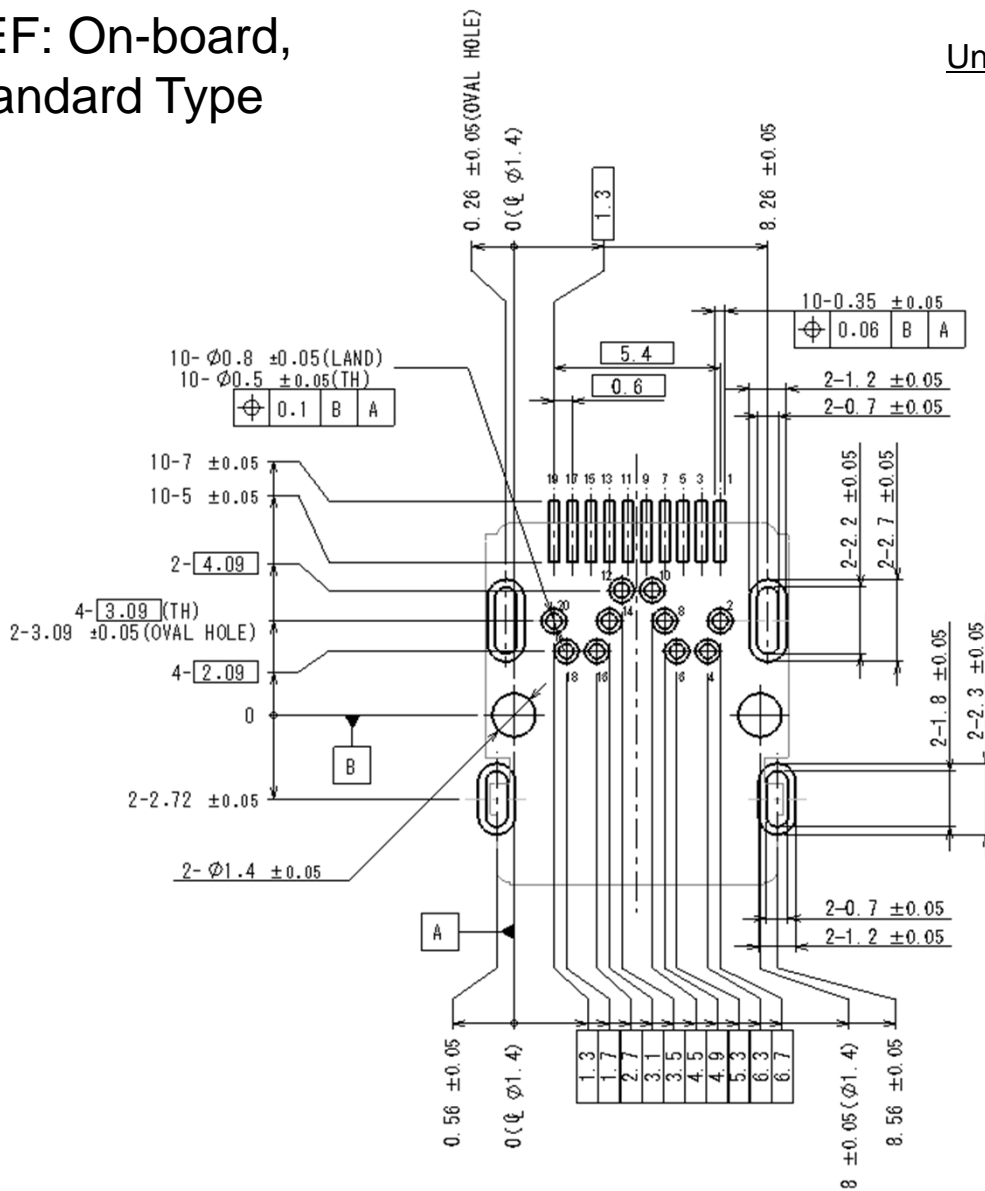

APPLICABLE P.C.B DIMENSION (REF.)
適合基板寸法 (参考)

Product Line-up

Horizontal Receptacles

Receptacle Type	Mounting Orientation	Height of Mating Centerline (from mounting surface)	Through-hole Pin Length	Part Number	SJ No.
Standard (top)	Standard	+ 3.2mm	2.1mm	DP3AR020SU32JQ1	SJ113423 (Individual Connector) SJ113424 (Embossed Reel)
Standard (top)	Standard	+ 3.2mm	1.4mm	DP3R020SU32JQ	SJ112287 (Individual Connector) SJ112331 (Embossed Reel)
Reverse	Reverse	+ 3.2mm	2.1mm	DP3R020RU32JQ1	SJ112290 (Individual Connector) SJ112334 (Embossed Reel)
Reverse	Reverse	+ 3.2mm	1.4mm	DP3R020RU32JQ	SJ112289 (Individual Connector) SJ113424 (Embossed Reel)
Mid-mount	Reverse	- 3.0mm	1.5mm	DP3R020RL30JQ	SJ112303 (Individual Connector) SJ112335 (Embossed Reel)
Mid-mount	Reverse	+ 0.5mm	1.5mm	DP3RB20RU05JQ	SJ112304 (Individual Connector) SJ112336 (Embossed Reel)

Vertical Receptacles

Receptacle Type	Contact Mounting	Hold-downs	Height	Part Number	SJ No.
Vertical	All SMT	Through-hole, 1.9mm	10.5mm	DP3AR020WQ1	SJ114076 (Individual Connector) SJ114077 (Embossed Reel)

* Please refer to SJ drawing when considering use of this product.

Notice:

1. The values specified in this brochure are only for reference. The products and their specifications are subject to change without notice. Contact our sales staff for further information before considering or ordering any of our products. For purchase, a product specification must be agreed upon.

2. Users are requested to provide protection circuits and redundancy circuits to ensure safety of the equipment, and sufficiently review the suitability of JAE's products to the equipment.

3. The products presented in this brochure are designed for the uses recommended below.

We strongly suggest you contact our sales staff when considering use of any of the products in any other way than the recommended applications or for a specific use that requires an extremely high reliability.

(1) Applications that require consultation:

(i) Please contact us if you are considering use involving a quality assurance program that you specify or that is peculiar to the industry, such as:

Automotive electrical components, train control, telecommunications devices (mainline), traffic light control, electric power, combustion control, fire prevention or security systems, disaster prevention equipment, etc.

(ii) We may separately give you our support with a quality assurance program that you specify, when you think of a use such as :

Aviation or space equipment, submarine repeaters, nuclear power control systems, medical equipment for life support, etc.

(2) Recommended applications include:

Computers, office appliances, telecommunications devices (terminals, mobile units), measuring equipment, audiovisual equipment, home electric appliances, factory automation equipment, etc

Japan Aviation Electronics Industry, Limited

* The specifications in this brochure are subject to change without notice. Please contact JAE for information.

Looking for pricing, stock, or lifecycle information?

Click below to explore more details on WIN SOURCE:

- ⊖ [View DP3AR020SU32JQ1R400 on WIN SOURCE](#)
- ⊖ [JAE Electronics Information](#)

Optimize Your Supply Chain with WIN SOURCE Solutions

- ✓ Global Sourcing Solution
- ✓ Obsolete Management
- ✓ Cost Control Management
- ✓ Shortage Management
- ✓ Alternative Solution
- ✓ Excess Inventory Management