



**THE DATASHEET OF
MAX77839BEFQ+T**



Click [here](#) to ask an associate for production status of specific part numbers.

MAX77839

5.5V Input, 4.4A/3.6A Switching Current 6 μ A I_Q Buck-Boost Converter

General Description

The MAX77839 is a highly-efficient buck-boost regulator with an industry leading quiescent current of 6 μ A targeted for one-cell Li-ion and down to any battery chemistry with 1.8V discharge voltage. It supports input voltages of 1.8V to 5.5V and an output voltage range of 2.3V to 5.3V. The IC provides two different switching current limits to optimize external component sizing based on given load current requirements ("A" and "B" = 4.4A (typ), "C" and "D" = 3.6A (typ)), and two different GPIO pin configurations ("A" and "C" = FPWM pin, "B" and "D" = POK pin). These options provide design flexibility that allow the IC to cover a wide range of applications and use cases while minimizing board space.

The IC features a single-resistor adjustable output voltage from 2.3V to 5.3V. A configurable GPIO pin allows to select either a FPWM mode control input or a POK open drain output, depending on the system requirements. Maxim's unique buck-boost controller technology provides high efficiency, excellent load and line transient response, and a seamless transition between buck and boost modes of operation.

The MAX77839 is available in both a 2.07mm x 1.51mm, 15-bump wafer-level package (WLP), and a 2.5mm x 2.0mm, 11-lead FC2QFN package.

Applications

- Asset Tracking/Fleet Management
- 5G/2G/GSM Cellular Power
- RF Amplifier
- Smartphones ToF/Facial and Gesture Recognition
- System Power Pre-Regulation
- Single-Cell Li-ion Battery Powered Devices

Benefits and Features

- Flexible System Integration
 - 1.8V to 5.5V Input Voltage Range
 - 2.3V to 5.3V Single Resistor Adjustable Output
 - 3A Maximum Output Current
 - 4.4A I_{LIM}, See [TOC 24](#) ("A" and "B" Options)
 - 3.6A I_{LIM}, See [TOC 23](#) ("C" and "D" Options)
 - 96% Peak Efficiency (V_{IN} = 3.6V, V_{OUT} = 3.3V)
 - Optional GPIO Pin (FPWM Input, POK Output)
- Low Supply Current that Extends Battery Life
 - Skip Mode that Reduces Supply Current at Light Loads
 - 6 μ A Ultra-Low I_Q
- 2.2MHz (typ) Switching Frequency
- Integrated Protections that Provide System Robustness
 - Undervoltage Lockout (UVLO)
 - Overvoltage Protection (OVP)
 - Cycle-by-Cycle Inductor Peak Current Limit
 - Thermal Shutdown (T_{SHDN})
- Active Output Discharge
- Small Solution Size
 - 2.07mm x 1.51mm, 0.4mm Pitch, 15-Bump WLP
 - 2.5mm x 2.0mm, 0.5mm Pitch, 11-Pin FC2QFN

[Ordering Information](#) appears at end of data sheet.

19-100983; Rev 2; 1/22

© 2021 Analog Devices, Inc. All rights reserved. Trademarks and registered trademarks are the property of their respective owners.

One Analog Way, Wilmington, MA 01887 U.S.A. | Tel: 781.329.4700 | © 2022 Analog Devices, Inc. All rights reserved.

Simplified Block Diagram

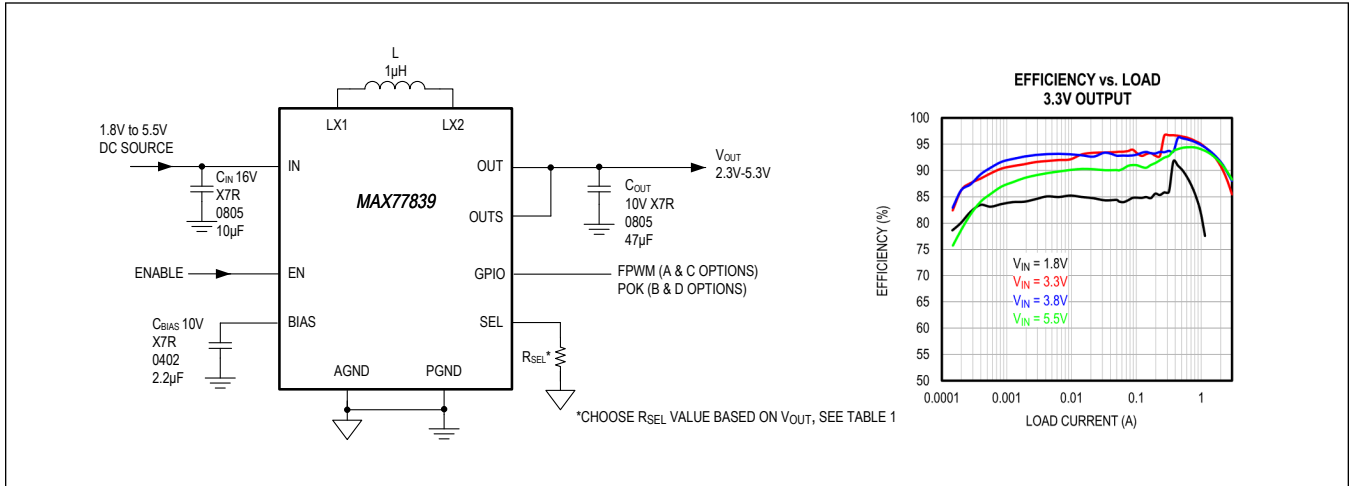

Absolute Maximum Ratings

IN, OUT, LX1, LX2, OUTS, BIAS to PGND, AGND . -0.3V to +6V
 PGND to AGND -0.3V to +0.3V
 EN, GPIO, SEL to AGND -0.3V to V_{BIAS} + 0.3V

Continuous Power Dissipation
 15 WLP Package (T_A = +70°C, derate 16.22mW/°C above
 +70°C (Note 1)) 1297.6mW
 11 FC2QFN Package (T_A = +70°C, derate 19.12 mW/°C above
 +70°C (Note 1)) 1529.6mW

Note 1: Package thermal resistances were obtained using the method described in JEDEC specification JESD51-7, using a four -layer board. For detailed information on package thermal considerations, refer www.maximintegrated.com/thermal-tutorial.

Stresses beyond those listed under "Absolute Maximum Ratings" may cause permanent damage to the device. These are stress ratings only, and functional operation of the device at these or any other conditions beyond those indicated in the operational sections of the specifications is not implied. Exposure to absolute maximum rating conditions for extended periods may affect device reliability.

Recommended Operating Conditions

PARAMETER	SYMBOL	CONDITION	TYPICAL RANGE	UNIT
Input Voltage	V _{IN}		1.8 to 5.5	V
Output Voltage	V _{OUT}		2.3 to 5.3	V
Output Current Range	I _{OUT}	For continuous operation at 3A, the junction temperature (T _J) is limited to +105°C for the WLP package. If the junction temperature is higher than +105°C, the expected lifetime at 3A continuous operation is derated. Boost mode operation is also limited by I _{LIM} .	0 to 3	A
Operating Junction Temperature	T _J		-40 to +125	°C

Note: These limits are not guaranteed.

Package Information

WLP

Package Code	W151K2Z+1
Outline Number	21-100441
Land Pattern Number	Refer to Application Note 1891
Thermal Resistance, Four Layer Board:	
Junction-to-Ambient (θ_{JA})	61.65C°/W

FC2QFN

Package Code	F112A2F+1
Outline Number	21-100431
Land Pattern Number	90-100154
Thermal Resistance, Four Layer Board:	
Junction-to-Ambient (θ_{JA})	52.30C°/W
Junction-to-Case Thermal Resistance (θ_{JC})	0.20C°/W

For the latest package outline information and land patterns (footprints), go to www.maximintegrated.com/packages. Note that a “+”, “#”, or “-” in the package code indicates RoHS status only. Package drawings may show a different suffix character, but the drawing pertains to the package regardless of RoHS status.

Package thermal resistances were obtained using the method described in JEDEC specification JESD51-7, using a four-layer board. For detailed information on package thermal considerations, refer to www.maximintegrated.com/thermal-tutorial.

Electrical Characteristics

(T_A ≈ T_J = -40°C to +125°C, typical values are at T_A ≈ T_J = +25°C, V_{IN} = +3.8V, R_{SEL} = Short to AGND, GPIO = Low (for A, C options), GPIO = Pull up to V_{IN} with 15k Ω resistor (for B, D options) unless otherwise noted. (Note 2)

PARAMETER	SYMBOL	CONDITIONS	MIN	TYP	MAX	UNITS
INPUT VOLTAGE AND SUPPLY CURRENT						
Operating Input Voltage	V _{IN}		1.8		5.5	V
Input Undervoltage Lockout (UVLO) Voltage	V _{UVLO_Rising}	Input rising	1.70	1.75	1.80	V
Input Undervoltage Lockout (UVLO) Hysteresis	V _{UVLO_Hys}			70		mV
Shutdown Supply Current	I _{SHDN}	EN = low, T _J = -40°C to +85°C			2	μ A
Input Quiescent Current	I _Q	EN = high, FPWM = low, T _J = -40°C to +125°C, no switching		6	14	μ A
	I _{Q_FPWM}	EN = high, FPWM = high, T _J = -40°C to +125°C, no switching		3		mA
Turn-On Delay Time	t _{DLY_ON}	From EN high to R _{SEL} reading		100		μ s
R _{SEL} Reading Time	t _{RSEL}		360	450	600	μ s
BUCK-BOOST CONVERTER						
Output Voltage Range	V _{OUT}	See R_{SEL} table	2.3		5.3	V
Output Voltage Accuracy	V _{OUT_ACC}	FPWM = high, T _J = +25°C, no load	-1.0		+1.0	%
		FPWM = low, T _J = +25°C, no load	-1.0		+3.5	
Switching Frequency	f _{SW}		1.936	2.20	2.464	MHz
High-Side Switching Current Limit	I _{LIM}	A, B options	4.05	4.4	4.75	A
		C, D options	3.24	3.6	3.96	
High-Side Switching Current Limit During Soft-Start	I _{LIM_SS}	A, B options	1.75	2.1	2.45	A
		C, D options	1.28	1.6	1.92	
Low-Side Switch On Resistance	R _{DSON_LO}	LX1, LX2		58		m Ω
High-Side Switch On Resistance	R _{DSON_HI}	LX1, LX2		50		m Ω
Thermal Shutdown Threshold	T _{SHDN}	T _J rising		150		°C
Thermal Shutdown Hysteresis	T _{SHDN_HYS}			15		°C
Active Discharge Resistance	R _{DSCHG}			100		Ω
Line Regulation	$\Delta V_{OUT}/\Delta V_{IN}$	V _{IN} = 1.8V to 5.5V, FPWM = high, no load, V _{OUT} = 3.3V, 5V	-0.3		+0.3	%/V
Load Regulation	$\Delta V_{OUT}/\Delta I_{OUT}$	I _{OUT} = 0A to full load, V _{IN} = 2.3V, 3.8V, 5.5V, V _{OUT} = 3.3V, 3.6V, 5V		±0.3		%/A
Soft-Start Timeout	t _{SS}			4		ms
Overvoltage Protection Threshold	V _{OVP}	V _{OUT} - V _{OUTS}		0.5		V

Electrical Characteristics (continued)

(T_A \approx T_J = -40°C to +125°C, typical values are at T_A \approx T_J = +25°C, V_{IN} = +3.8V, R_{SEL} = Short to AGND, GPIO = Low (for A, C options), GPIO = Pull up to V_{IN} with 15k Ω resistor (for B, D options) unless otherwise noted. (Note 2)

PARAMETER	SYMBOL	CONDITIONS	MIN	TYP	MAX	UNITS
DIGITAL LOGIC (EN, GPIO)						
Input Logic-Low Level	V _{IL}				0.4	V
Input Logic-High Level	V _{IH}		1.3			V
Internal Pulldown Resistance	R _{PD}	EN, GPIO (A, C options)		800		k Ω
Output Logic-Low Level	V _{OL}	GPIO pin (B, D options), pullup voltage = 3.3V, I _{OL} = 1mA			0.4	V

Note 2: Limits are 100% production tested at T_A \approx T_J = +25°C. The MAX77839 is tested under pulsed load conditions such that T_A \approx T_J. Limits over the operating temperature range (T_J = -40°C to +125°C) are guaranteed by design and characterization using statistical process control methods.

Typical Operating Characteristics

(V_{IN} = 3.8V, V_{OUT} = 3.3V, L = 1µH (Coilcraft XAL4020-102ME), Skip Mode, I_{LIM_LX} = 4.4A, T_A = +25°C, unless otherwise noted.)

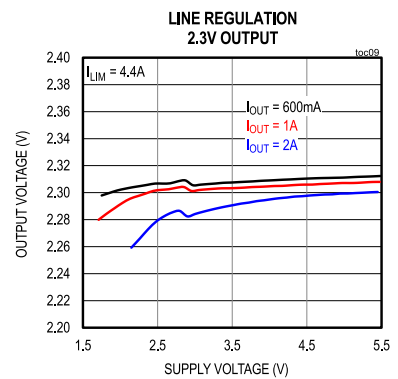
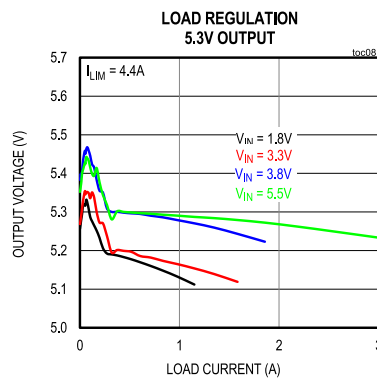
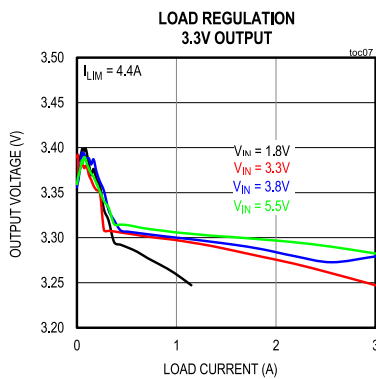
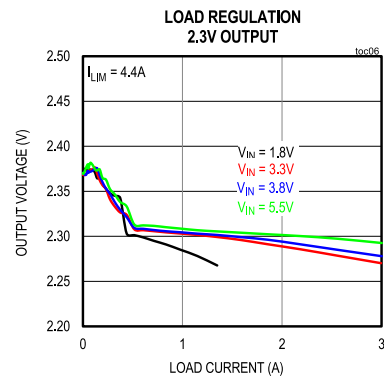
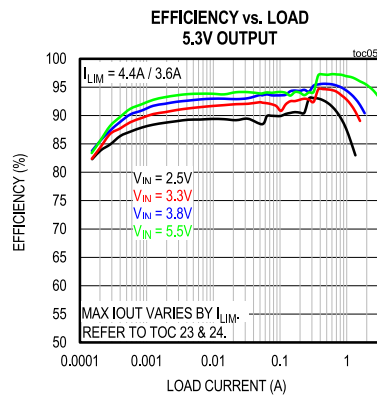
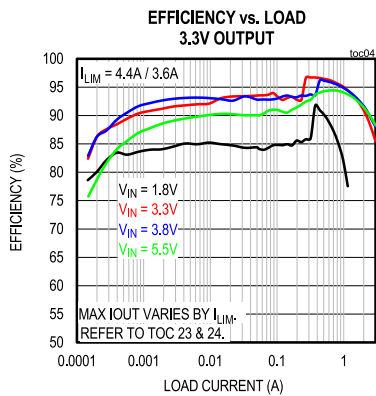
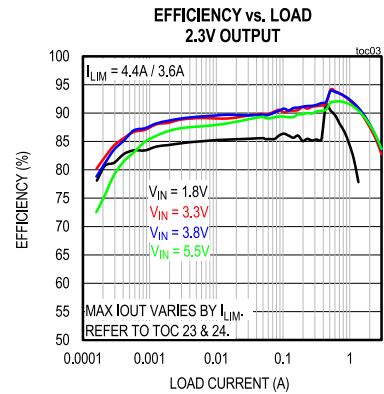
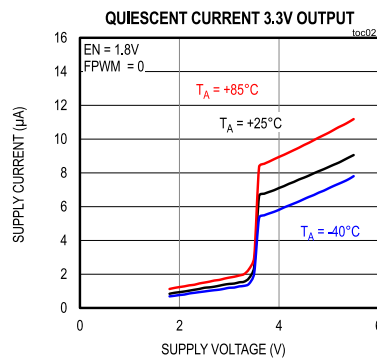
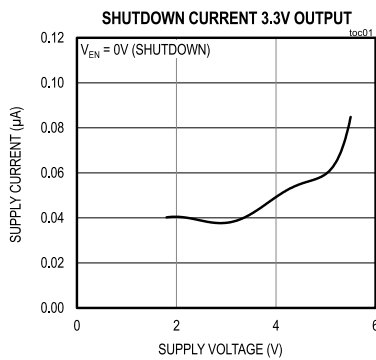

Typical Operating Characteristics (continued)

(V_{IN} = 3.8V, V_{OUT} = 3.3V, L = 1 μ H (Coilcraft XAL4020-102ME), Skip Mode, I_{LIM_LX} = 4.4A, T_A = +25°C, unless otherwise noted.)

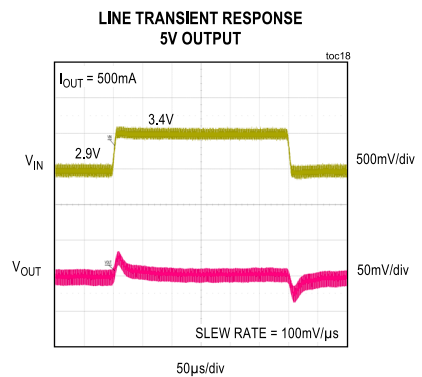
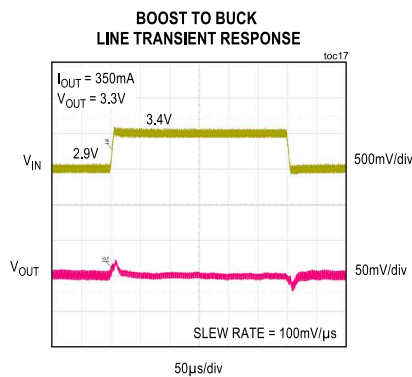
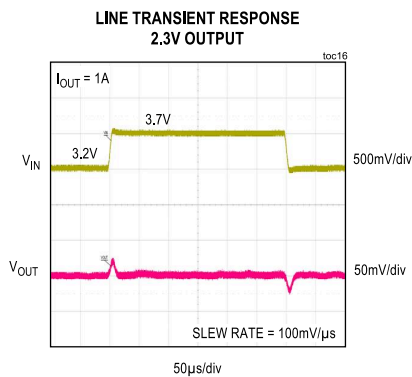
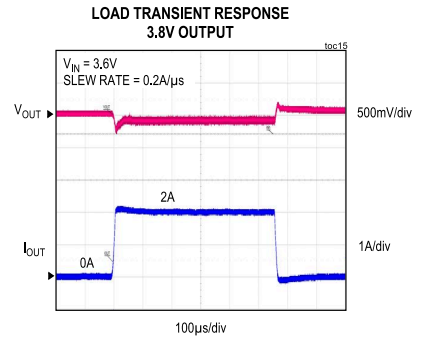
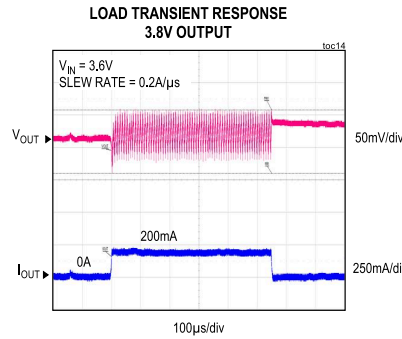
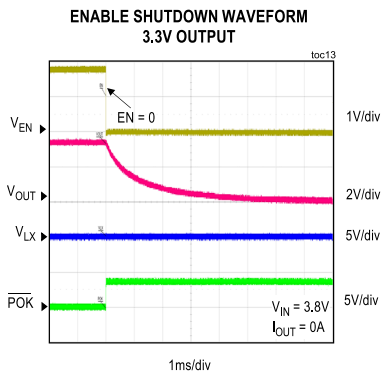
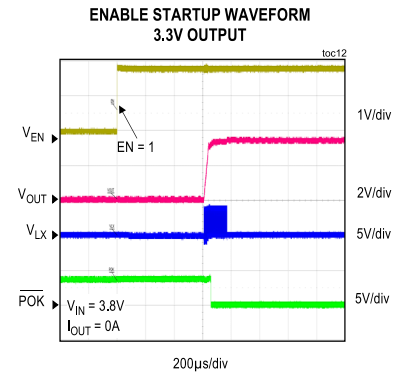
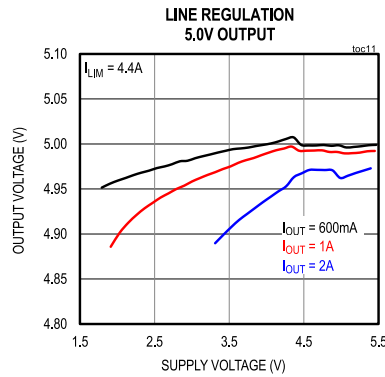
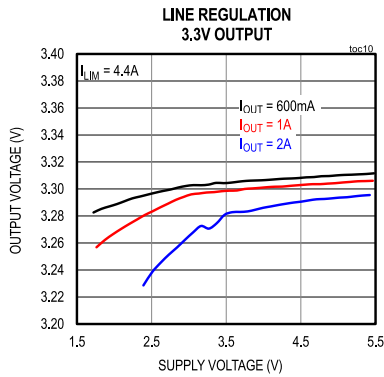

Typical Operating Characteristics (continued)

(V_{IN} = 3.8V, V_{OUT} = 3.3V, L = 1 μ H (Coilcraft XAL4020-102ME), Skip Mode, I_{LIM_LX} = 4.4A, T_A = +25°C, unless otherwise noted.)

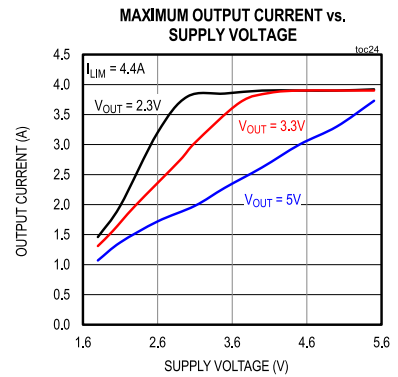
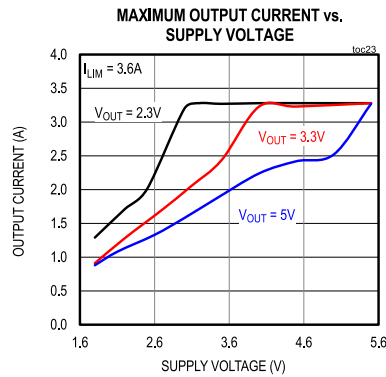
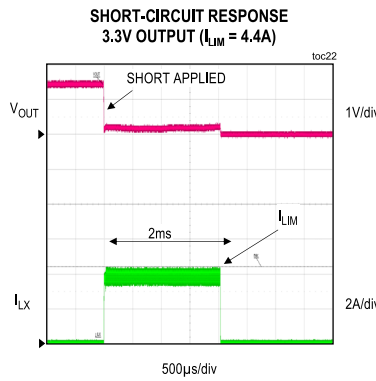
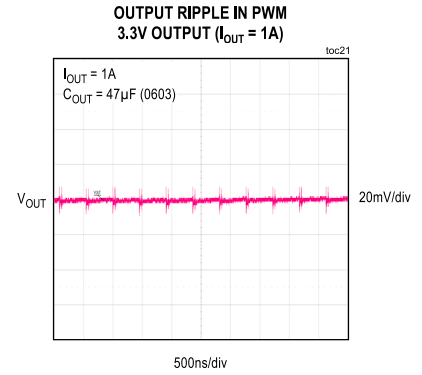
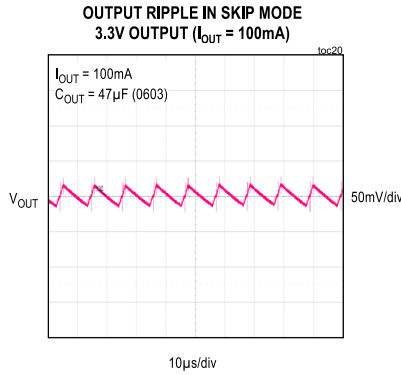
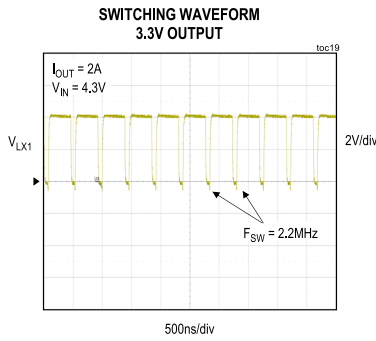

Pin Configurations

WLP

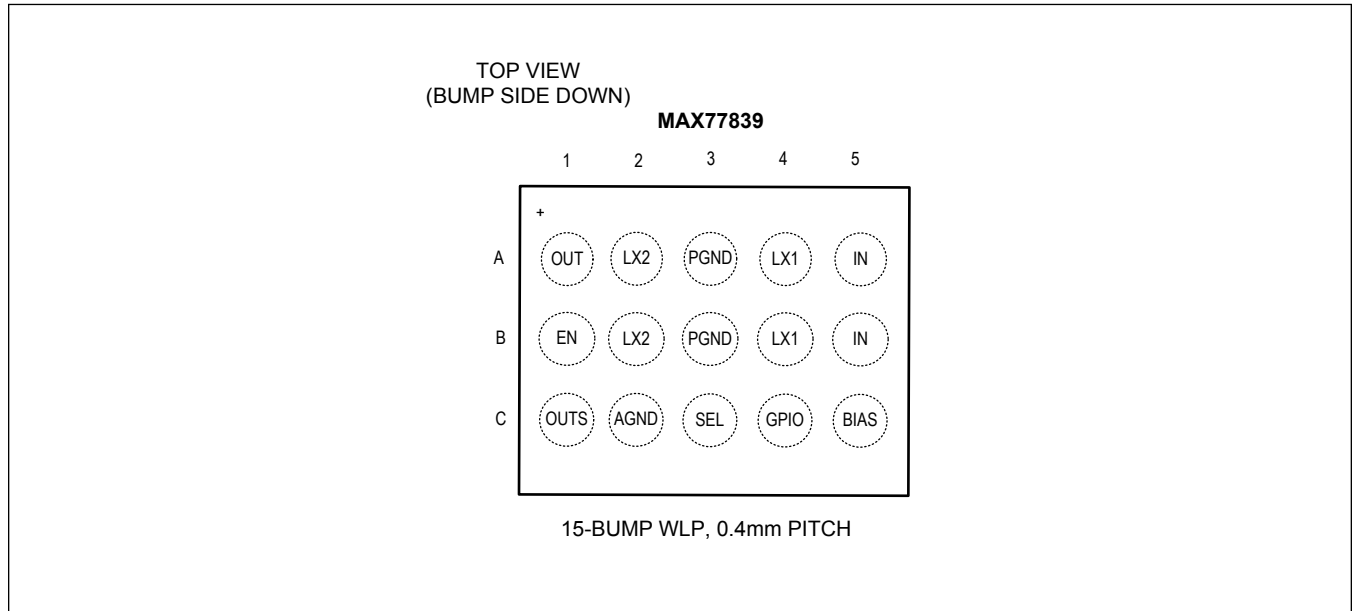

FC2QFN

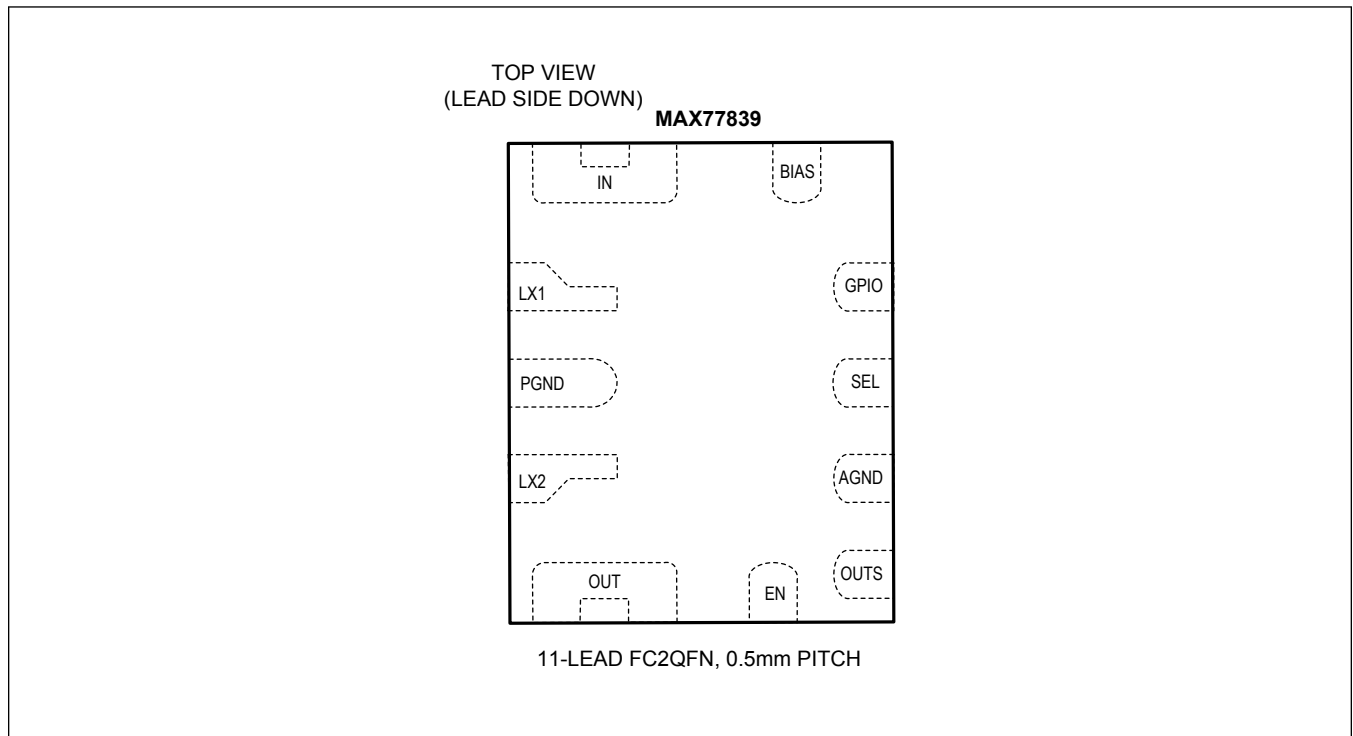

Pin Description

PIN		NAME	FUNCTION	TYPE
WLP	FC2QFN			
A5, B5	11	IN	Buck-Boost Input. Bypass to PGND with two 16V 10 μ F X7R ceramic capacitors.	Analog
C5	10	BIAS	Internal Bias Supply. Bypass to AGND with a 10V 2.2 μ F X7R ceramic capacitor. Do not load this pin externally.	Power Output
A4, B4	1	LX1	Input-Side Buck-Boost Switching Node	Power
C4	9	GPIO	GPIO pin. For A, C options, forced-PWM mode digital input. Apply high for FPWM mode, apply low for auto skip mode operation. For B, D options, \overline{POK} open drain output. Pull up with 15k Ω resistor to IO voltage.	Digital Input/ Output
A3, B3	2	PGND	Power Ground	Ground
C3	8	SEL	Output Voltage Selection Input. Connect a resistor between this pin and ground to configure the output voltage. Consult Output Voltage Configuration for a table of recommended resistors and corresponding output voltages.	Analog
A2, B2	3	LX2	Output-Side Buck-Boost Switching Node	Power
C2	7	AGND	Analog Ground	Ground
A1	4	OUT	Buck-Boost Power Output. Bypass to PGND with two 16V X7R 10 μ F ceramic capacitors.	Power
B1	5	EN	Buck-Boost Enable Input	Digital Input
C1	6	OUTS	Buck-Boost Output Voltage Sense Input. Connect to the output at the point-of-load.	Analog

Functional Diagrams

Functional Block Diagram

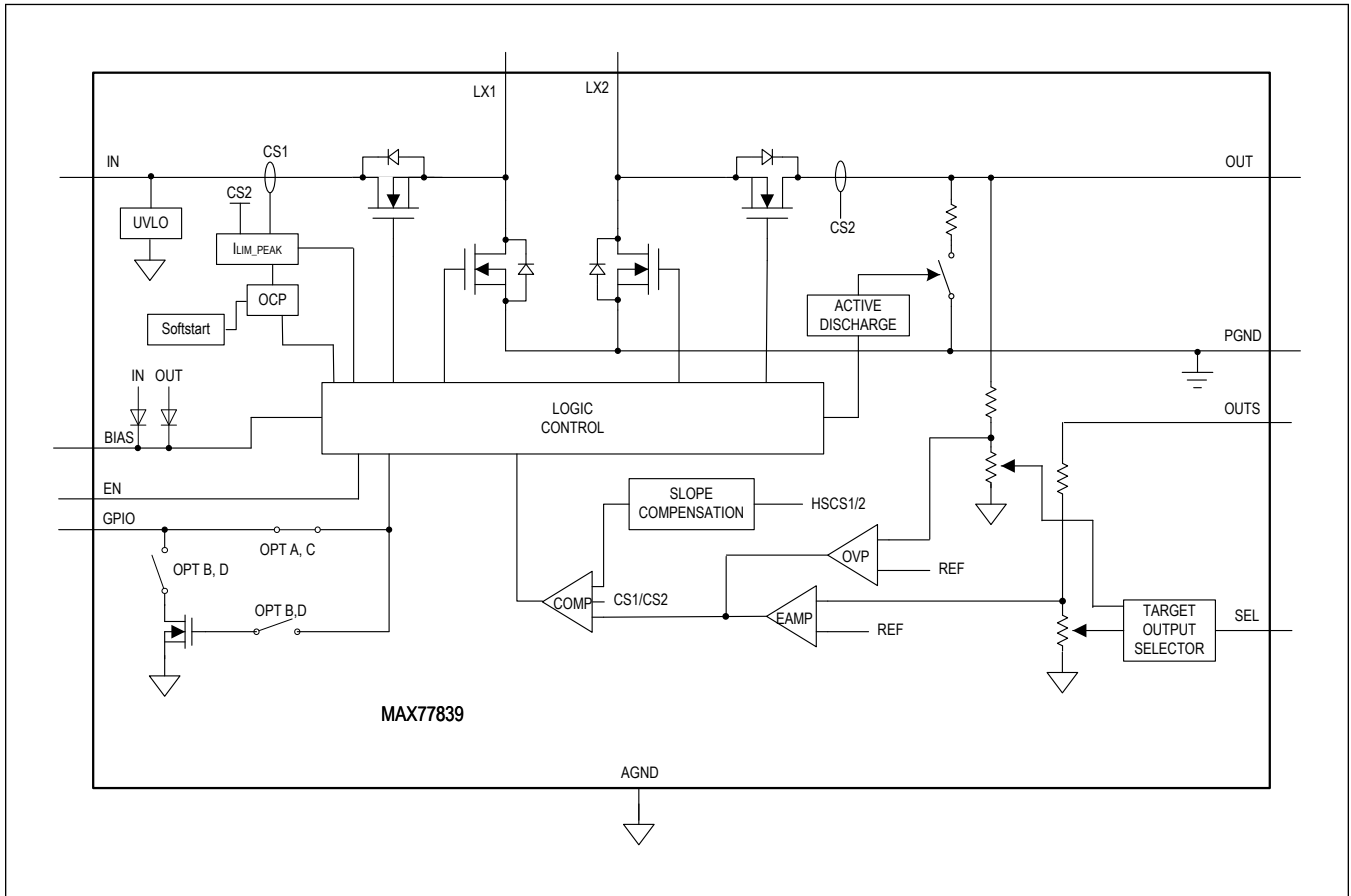

Detailed Description

The MAX77839 is a simple, high-efficiency buck-boost regulator with a wide input voltage range for single cell Li-ion batteries, two cell AA batteries, LiSOC12 batteries, or any battery chemistry with a 1.8V discharge voltage. The converter seamlessly transitions between buck and boost modes of operation. It includes two GPIO options for FPWM enable (options A and C) or $\overline{\text{POK}}$ open drain output (options B and D). The MAX77839 is also equipped with active output discharge, selection of two different inductor peak current limits, and various protections to ensure robustness in harsh operating conditions. The IC is available in WLP and FC2QFN packages.

Startup and Shutdown

Startup

When the EN pin is set to high, the IC turns on the internal bias circuitry, which takes typically 100 μ s ($t_{\text{ON_DLY}}$) to settle. After the internal bias circuitry is settled, the controller senses the SEL pin resistance to set the reference voltage. The R_{SEL} reading takes about 450 μ s (t_{RSEL}). After the IC reads the R_{SEL} value, it begins the soft-start process.

To limit the inrush current during soft-start, the MAX77839 reduces the switching current limit level to about half of the normal level. Soft-start time ends when the output voltage reaches the target regulation point, and then increases the switching current limit level to the normal level. After an additional 100 μ s of transition time, the MAX77839 switches over to normal switching control (Skip mode). Note that the part switches in FPWM for the entire duration of t_{SS} .

The MAX77839 is equipped with a soft-start time out timer ($t_{\text{SS}} = 4\text{ms}$ (typ)), and if the output voltage does not reach the target regulation point (90% of V_{TARGET}), then the MAX77839 latches off and does not start up until EN or V_{IN} is cycled.

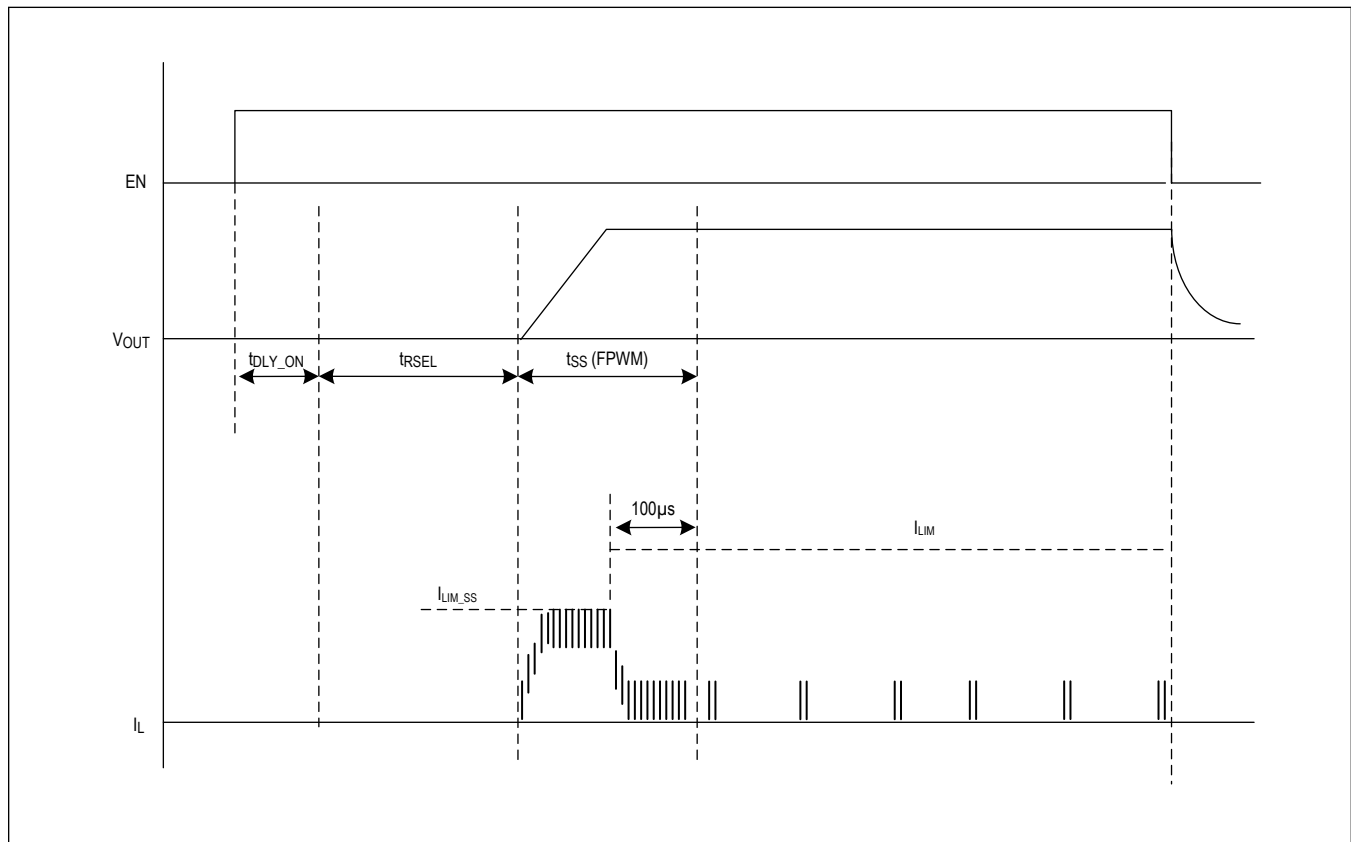

Figure 1. Startup Waveform

Immediate Shutdown Conditions

The converter stops switching whenever the MAX77839 is disabled by EN control or is latched off by protections. After the converter stops switching, the MAX77839 turns on the active discharge switch between OUT and PGND to quickly discharge the output capacitor.

There are also several conditions that cause latch off, regardless of EN state:

- Thermal shutdown (T_{SHDN})
- Soft-start timeout (T_{SS})
- Continuous I_{LIM} events for about 2ms (typ)
- Undervoltage Lockout (UVLO)

The events in this category shutdown the output. The converter can start up again once fault conditions are removed from the system and VIN or EN is toggled.

Protections

Thermal Shutdown

The device has an internal thermal-protection circuit that monitors die temperature. The buck-boost disables if the die temperature exceeds T_{SHDN} (+150°C typ). The buck-boost can be enabled again after the die temperature cools by approximately +15°C.

Undervoltage Lockout

The device supports a UVLO feature that prevents operation in abnormal input voltage conditions when V_{IN} falls below the V_{UVLO_Falling} threshold. The device enables when both the input voltage V_{IN} rises above the V_{UVLO_Rising} threshold and EN is pulled high.

Overcurrent Protection

The device features a robust switching current-limit scheme that protects the device and the inductor during overload and fast transient conditions. The current-sense circuit takes current information from the high-side MOSFETs to determine the peak-switching current (R_{DS(ON)} × I_L).

The IC provides two different cycle-by-cycle current limit levels (3.6A (typ) and 4.4A (typ)) for the high-side MOSFET. If the switching current hits current limit (I_{LIM}) for about 2ms, the IC shuts off the output. An overcurrent event removed within 2ms allows the converter to recover and regulate normally.

Toggle the EN pin to reenble the buck-boost converter if it is latched off by an overcurrent event lasting longer than 2ms.

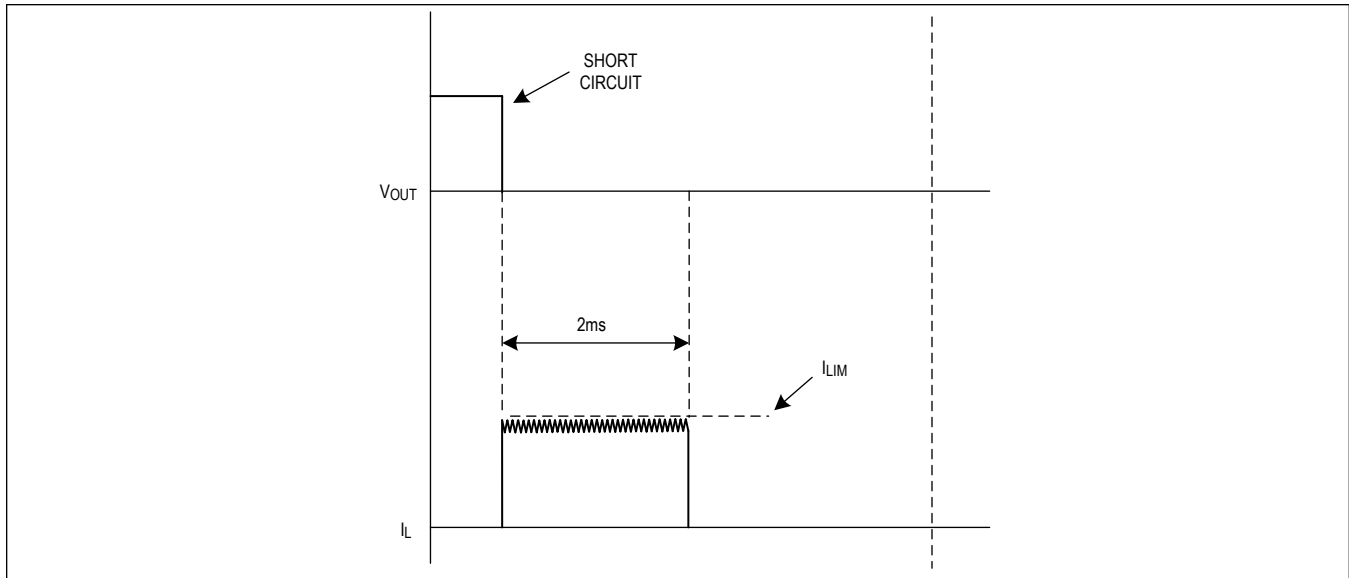

Figure 2. Short-Circuit Waveform

Overvoltage Protection

The IC detects the voltage difference between OUT and OUTS, and if the voltage difference (OUT - OUTS) exceeds the OVP threshold voltage level (0.5V typ), then the device turns off all switches. This prevents OUTS = OPEN conditions from overdriving the output beyond safe operating ranges. Additionally, the device shuts off whenever OUTS detects a voltage over 20% of the target output value (10% when OUT target set above 5V).

Control Scheme

The MAX77839 utilizes a four-switch H-bridge architecture to realize both buck and boost operating modes. It regulates the output voltage to a target value at any valid input voltage and provides great response to both line and load transient events. Fast switching frequency and a unique control algorithm allow for small external components, low output noise, and high-efficiency across the entire operating range.

The buck-boost converter operates using a 2.2MHz fixed-frequency pulse width modulation (PWM) control scheme with current-mode compensation. The architecture integrates four FETs operating as switches: an input high-side FET (HS1), input low-side FET (LS1), output high-side FET (HS2), and output low-side FET (LS2). A proprietary algorithm controls these switches in four different phases:

- Phase 1 ($\Phi 1$): HS1 and LS2 switch on to store energy in the inductor by ramping up inductor current at a rate determined by the input voltage and the inductance: $\frac{dI_L}{dt} = \frac{V_{IN}}{L}$
- Phase 2 ($\Phi 2$): HS1 and HS2 switch on to either charge or discharge the inductor, depending on the difference between the input and output voltage. In boost mode, $V_{OUT} > V_{IN}$ and the inductor current ramps down. In buck mode, $V_{IN} > V_{OUT}$ and the inductor current ramps up: $\frac{dI_L}{dt} = \frac{V_{IN} - V_{OUT}}{L}$
- Phase 3 ($\Phi 3$): LS1 and HS2 switch on to discharge the inductor by ramping down inductor current at a rate determined by the output voltage and the inductance: $\frac{dI_L}{dt} = \frac{-V_{OUT}}{L}$
- Phase 4 ($\Phi 4$): LS1 and LS2 switch on to disconnect the inductor from output and input voltages

Soft-start utilizes $\Phi 1$ and $\Phi 3$ to ramp the output voltage up.

Boost mode ($V_{IN} < V_{OUT}$) utilizes $\Phi 1$ and $\Phi 2$ within a single clock period. See [Figure 3](#) for a graphical representation.

Buck mode ($V_{IN} > V_{OUT}$) utilizes $\Phi 2$ and $\Phi 3$ within a single clock period. See [Figure 3](#) for a graphical representation.

Skip mode is initiated by consequent zero crossings of high side (HS2) switching current. In skip mode, device switching

is controlled by output voltage. The converter increases the target regulation point to VOUT_SKIP_H (about 3% higher than regulation target), and continues switching to ramp up the output voltage until the output voltage reaches VOUT_SKIP_H. When the output voltage reaches VOUT_SKIP_H, Φ4 discharges the inductor current until output voltage drops to VOUT_SKIP_L (about 1% higher than regulation target) level. This cycle continues until the output voltage does not reach the target level for six switching cycles.

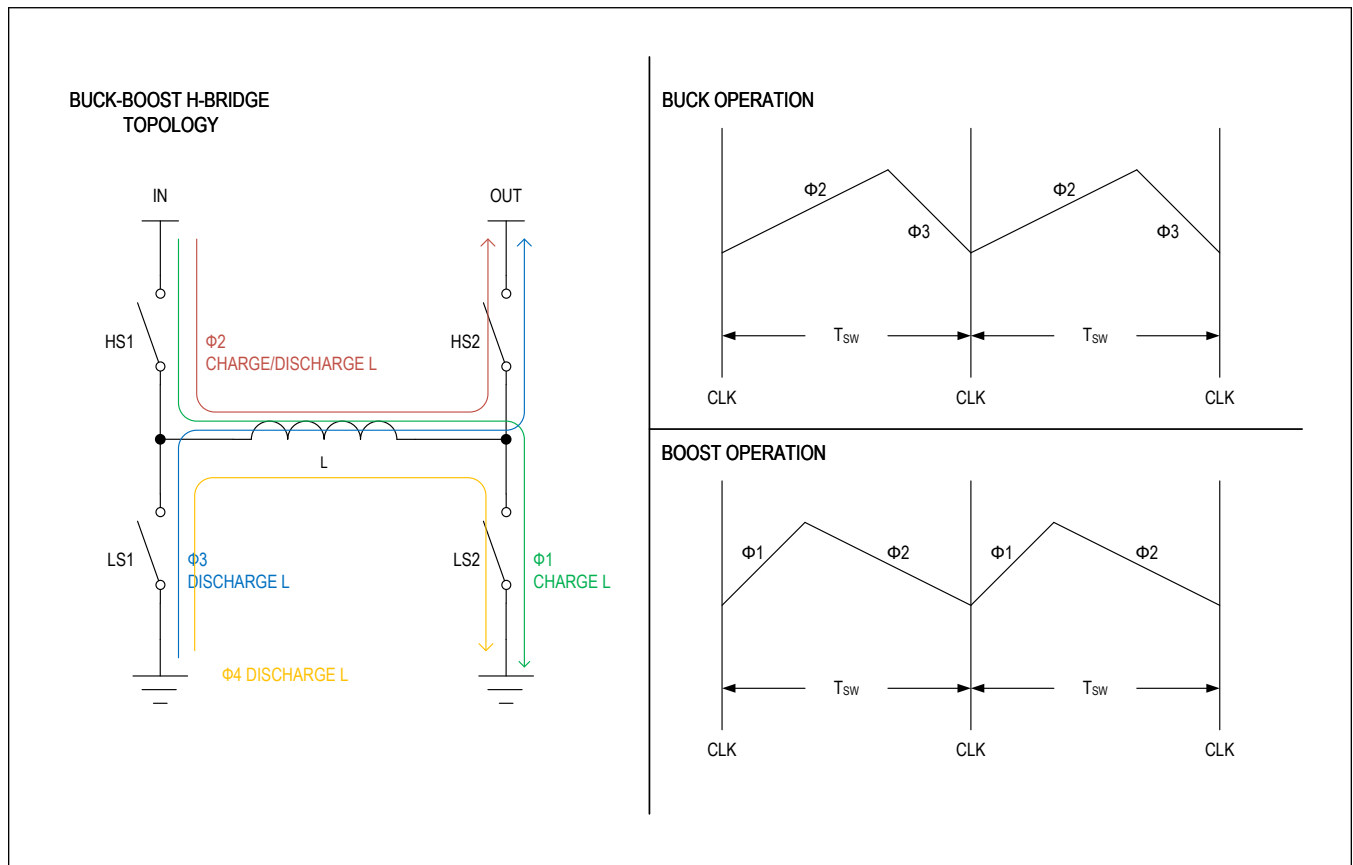

Figure 3. Buck-Boost H-Bridge Topology

Output Voltage Configuration

Set the output voltage by connecting a resistor (R_{SEL}) to the SEL pin of the MAX77839. The device uses this resistance to calculate the target output voltage. Choose a resistor with 1% tolerance or better. [Table 1](#) lists recommended values for R_{SEL} to achieve different output voltages.

Table 1. R_{SEL} Selection Table

V _{OUT} (V)	R _{SEL} (kΩ)
3.3	Short (0Ω)
2.3	4.99
2.4	5.90
2.5	7.15
2.6	8.45
2.7	10.0
2.8	11.8

Table 1. R_{SEL} Selection Table (continued)

V _{OUT} (V)	R _{SEL} (k Ω)
2.9	14.0
3.0	16.9
3.1	20.0
3.2	23.7
3.4	28.0
3.5	34.0
3.6	40.2
3.7	47.5
3.8	56.2
3.9	66.5
4.0	80.6
4.1	95.3
4.2	113
4.3	133
4.4	162
4.5	191
4.6	226
4.7	267
4.8	324
4.9	383
5.0	452
5.1	536
5.2	634
5.3	768
2.85	909 or Open

Output Active Discharge

The buck-boost provides an internal 100 Ω resistor that switches on for the output active discharge function. The internal switch provides a path to discharge the energy stored in the output capacitor to PGND whenever the regulator is disabled by EN or any protections. While the regulator remains enabled, the internal switch is disconnected from the output.

GPIO Pin

The MAX77839 includes two GPIO options which can be either a digital input pin for FPWM enable (A and C options) or an open drain output for $\overline{\text{POK}}$ signal (B and D options). When FPWM is enabled, the converter operates in PWM mode regardless of load. If the FPWM enable pin is chosen as the GPIO option, when FPWM is disabled, the converter operates in auto skip mode and utilizes skip mode when it detects a zero crossing in switching current to reduce switching losses. Applications that require low output ripple or fast load transients at all conditions should consider the FPWM option. When the $\overline{\text{POK}}$ output pin is chosen as the GPIO option, the open drain output pin pulls LOW if the output reaches within $\pm 10\%$ of the target voltage. Applications that require a POK signal for controlling the power-up sequence should consider the POK option.

Applications Information

Input Capacitor Selection

Bypass IN with a 10V, X7R, 10μF nominal input capacitor (C_{IN}). Larger values improve decoupling of the buck-boost regulator and filter the switching noise for the system. The RMS current rating of the input capacitor needs to be higher than $\sqrt{D(1-D) \times I_o^2 + \frac{1}{12}(D)dl^2}$ in buck mode, where dl is inductor current ripple, D is the duty cycle, and I_o is the load current. Consider using multiple capacitors in parallel to meet this spec if necessary.

Output Capacitor Selection

The minimum effective capacitance of 4.7μF for the output capacitor is required for small output ripple and ensuring stable operation of the buck-boost regulator. Determine the expected effective C_{OUT} carefully by considering the capacitor's initial tolerance, variation with temperature, and derating with DC bias voltage. Refer to [Tutorial 5527](#) for more information. The RMS current rating of the effective output capacitor needs to be higher than $\sqrt{D(1-D) \times I_o^2 + \frac{1}{12}(D)dl^2}$ in boost mode, where dl is the inductor current ripple, D is the duty cycle, and I_o is the load current.

A 10V, 22μF ceramic capacitor is recommended for most applications. Ceramic capacitors with X7R dielectrics are highly recommended for better effective capacitance, capacitance tolerance over bias voltage and temperature variations.

Inductor Selection

The MAX77839's current sensing circuit and compensation loop is optimized for 1μH inductance. An inductor with a saturation current that is greater than or equal to the peak current limit setting (I_{LIM}), and an RMS current rating based off the expected continuous peak inductor current at given max load current is recommended. Lower DCR increases buck-boost efficiency. Recall that there are two different I_{LIM} options for the MAX77839. [Table 2](#) lists recommended inductors for each I_{LIM} option. Note that this table was generated in 2019, and as inductor technology improves rapidly, may not be the most up-to-date at the time of reading.

Table 2. Recommended Inductors

MANUFACTURER	PART NUMBER	INDUCTANCE (μH)	DC RESISTANCE (mΩ)	SATURATION CURRENT (A)	RMS CURRENT FOR 40°C TEMPERATURE RISE (A)	DIMENSIONS L x W x H (mm)	OPTION
Cyntec	HTEK20161T-1R0MSR	1.0	35	4.2	4.1	2.0 x 1.6 x 1.0	C, D
Samsung	CIGT252010TM1R0MLE	1.0	21	5.5	5.3	2.5 x 2.0 x 1.0	A, B, C, D
Cyntec	HTEP25201T-1R0MSR	1.0	18	5.5	5.7	2.5 x 2.0 x 1.0	A, B, C, D
Cyntec	HTEH25201T-1R0MTR	1.0	21	5.5	5.7	2.5 x 2.0 x 1.0	A, B, C, D
Coilcraft	XEL4020-102ME	1.0	13.25	9.0	9.6	4.0 x 4.0 x 2.1	A, B, C, D

PCB Layout Guidelines

Careful circuit board layout is critical to achieve low switching power losses and clean, stable operation. For the WLP and FC2QFN package, a high density interconnect (HDI) PCB is not required. [Figure 4](#) shows an example non-HDI PCB layout for the MAX77839 WLP package, and [Figure 5](#) shows an example non-HDI PCB layout for the MAX77839 FC2QFN package.

When designing the PCB, follow these guidelines:

1. Place the input capacitors C_{IN} and output capacitors C_{OUT} immediately next to the IN pin and OUT pin, respectively, of the IC. The trace between the capacitors' ground pin to the IC PGND pin needs to be routed through the component mounting layer to minimize trace parasitics. Additionally, the trace for these connections needs to be as short and wide as possible. Since the IC operates at a high switching frequency, this placement is critical for minimizing parasitic inductance within the input and output current loops, which can cause high voltage spikes and can damage the internal switching MOSFETs.
2. Place the inductor next to the LX bumps/pins (as close as possible), route inductor traces through vias, and make the traces between the LX bumps/pins and the inductor short and wide to minimize PCB trace impedance. Excessive PCB impedance reduces converter efficiency. When routing LX traces on a separate layer (as in the examples), make sure to include enough vias to minimize trace impedance. Routing LX traces on multiple layers is recommended to further reduce trace impedance. Furthermore, do not allow LX traces to take up an excessive amount of area. The voltage on this node switches very quickly and additional area creates more radiated emissions.
3. Prioritize the low-impedance ground plane of the PCB directly underneath the IC, C_{OUT} , C_{IN} , and the inductor. Cutting this ground plane risks interrupting the switching current loops.
4. AGND must carefully connect to PGND on the PCBs low-impedance ground plane. Connect AGND to the low-impedance ground plane on the PCB (the same net as PGND) away from any critical loops.
5. The IC requires a supply input (BIAS) which is often the same net as IN. Carefully bypass BIAS to PGND with a dedicated capacitor (C_{BIAS}) as close as possible to the IC. Route a dedicated trace between C_{BIAS} and the BIAS bump/pin. Avoid connecting BIAS directly to the nearest IN bumps/pins without dedicated bypassing.
6. Connect the OUTS bump/pin to the regulating point with a dedicated trace away from noisy nets such as LX1 and LX2.
7. Keep the power traces and load connections short and wide. This is essential for high converter efficiency.
8. Do not neglect ceramic capacitor DC voltage derating. Choose capacitor values and case sizes carefully. See the [Output Capacitor Selection](#) section and refer to [Tutorial 5527](#) for more information.

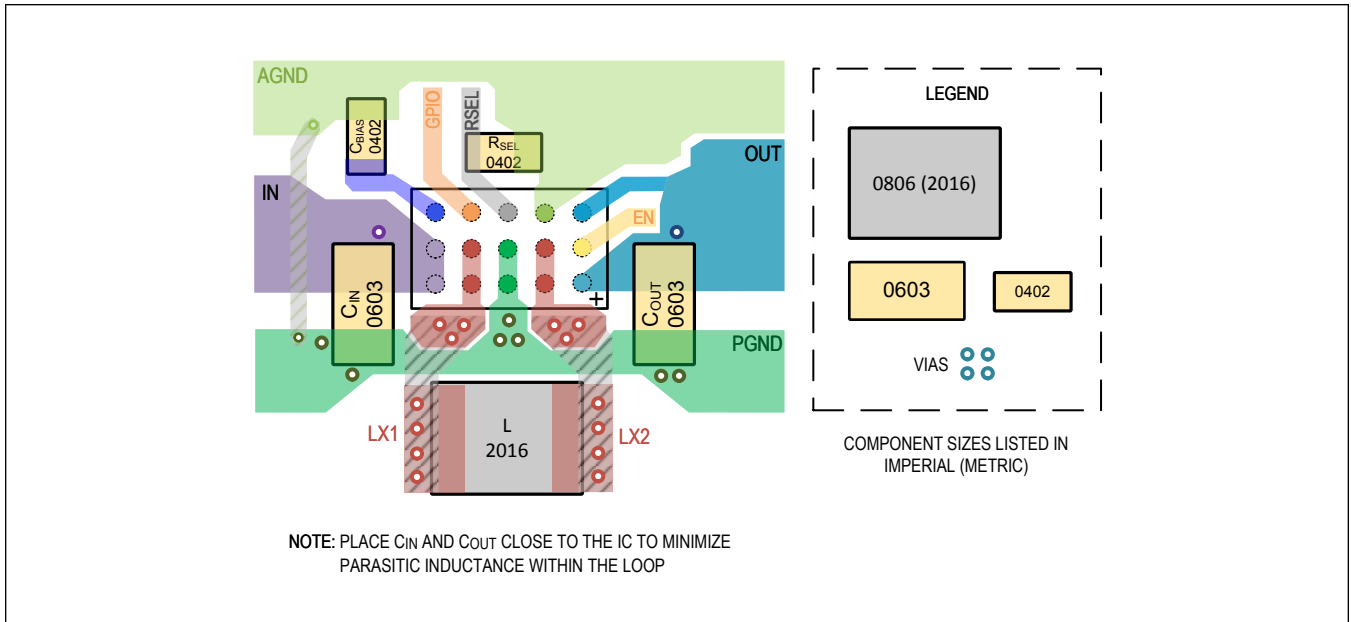

Figure 4. PCB Layout Example (WLP)

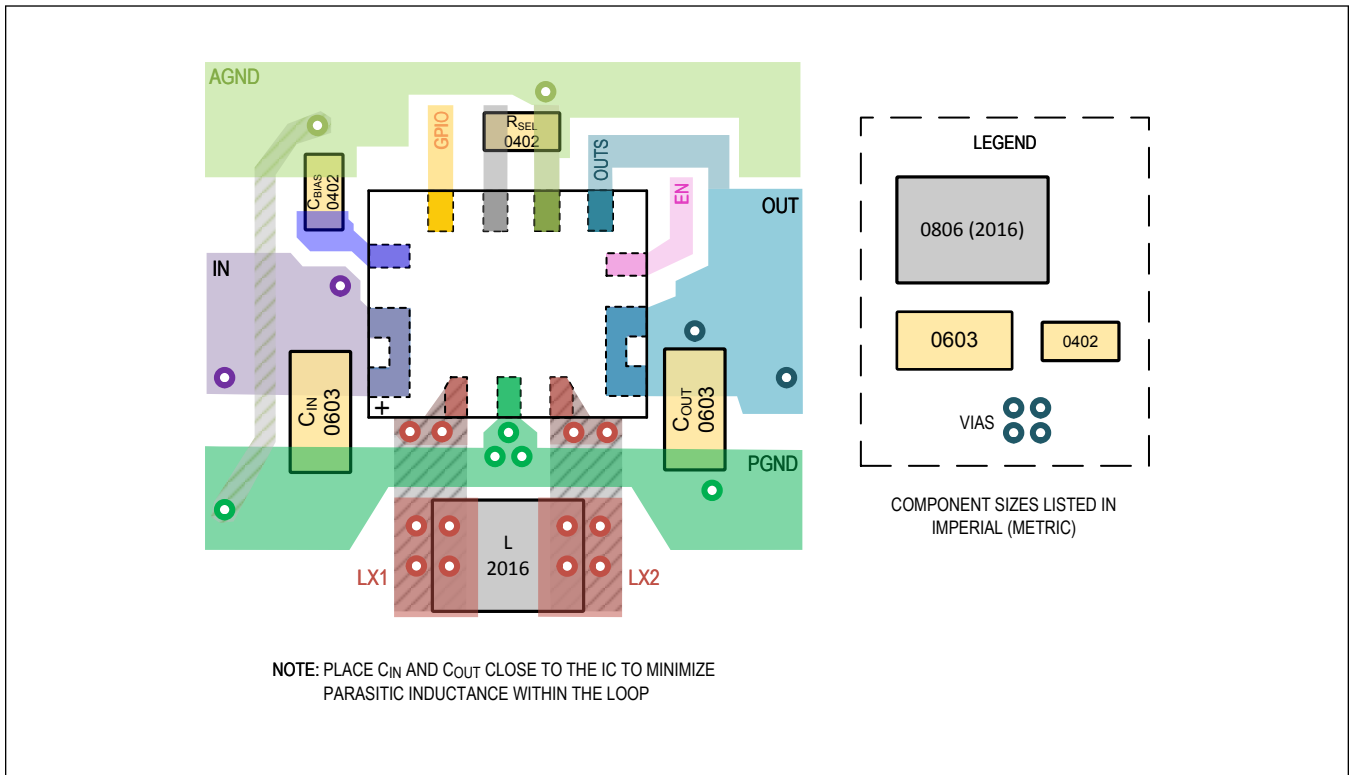

Figure 5. PCB Layout Example (FC2QFN)

Typical Application Circuits

Typical Application Circuit

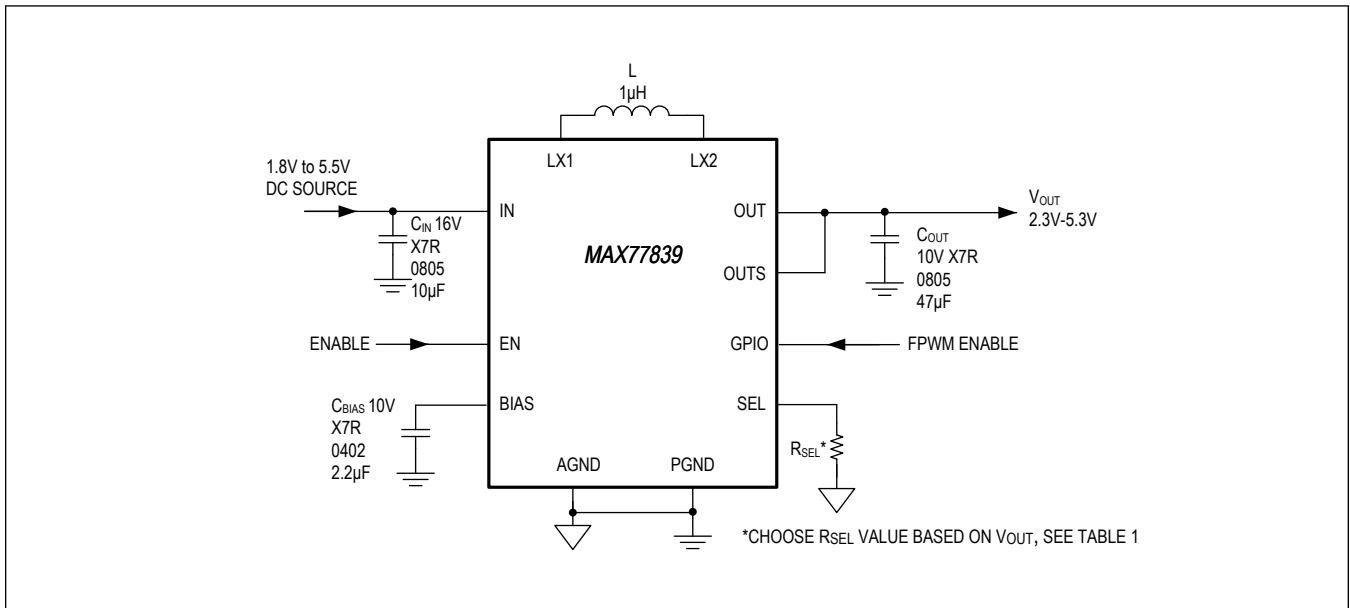

Figure 6. Options A and C

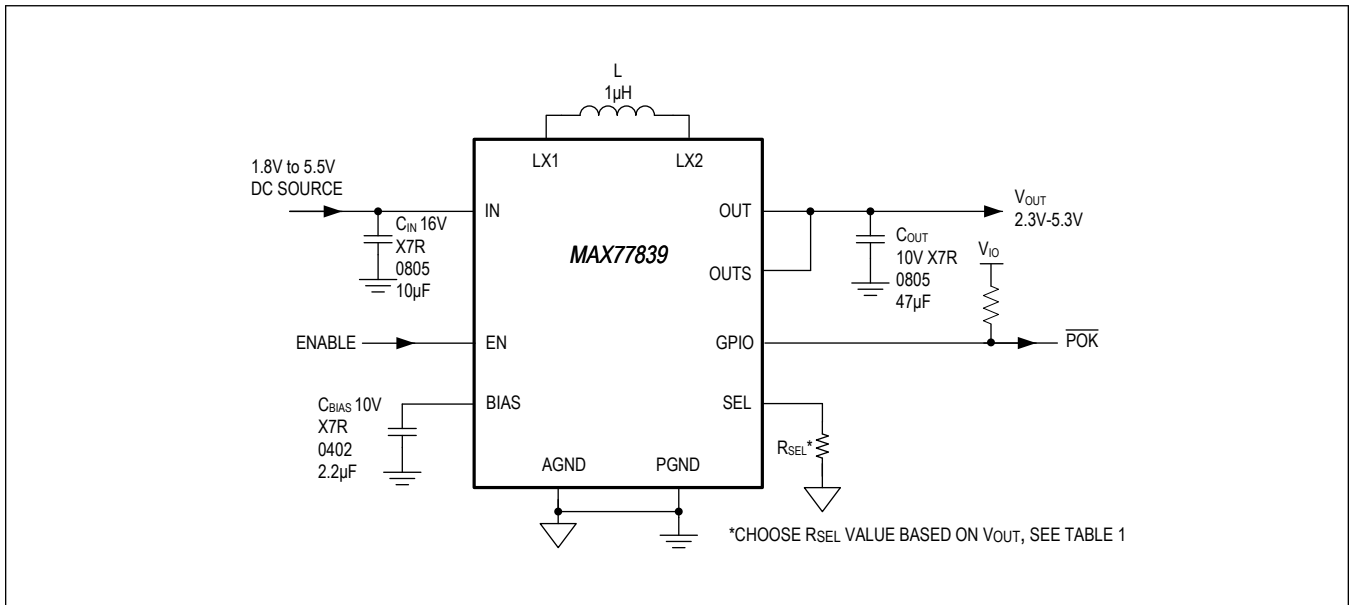

Figure 7. Options B and D

MAX77839

5.5V Input, 4.4A/3.6A Switching Current 6 μ A I_Q
Buck-Boost Converter**Ordering Information**

PART NUMBER	I _{LIM} OPTION (A)	GPIO FUNCTION	PIN-PACKAGE
MAX77839AEWL+T	4.4	FPWM	15 WLP
MAX77839AEFQ+T			11 FC2QFN
MAX77839BEWL+T		POK	15 WLP
MAX77839BEFQ+T			11 FC2QFN
MAX77839CEWL+T	3.6	FPWM	15 WLP
MAX77839CEFQ+T			11 FC2QFN
MAX77839DEWL+T		POK	15 WLP
MAX77839DEFQ+T			11 FC2QFN

+Denotes a lead(Pb)-free/RoHS-compliant package.



T = Tape and reel.

Revision History

REVISION NUMBER	REVISION DATE	DESCRIPTION	PAGES CHANGED
0	12/20	Initial release	—
1	6/21	Updated <i>General Description, Benefits and Features, Absolute Maximum Ratings, Recommended Operating Conditions, Package Information, Startup and Shutdown, Protections, Undervoltage Lockout, Overcurrent Protection, Output Active Discharge, GPIO Pin, Input Capacitor Selection, Output Capacitor Selection, Inductor Selection, PCB Layout Guidelines, and Typical Application Circuits</i> section, updated TOCs 3, 4, and 5, updated <i>Ordering Information</i> table	1, 3, 4, 7, 13, 14, 17–21, 23
2	1/22	Updated <i>Ordering Information</i> table	22

Looking for pricing, stock, or lifecycle information?

Click below to explore more details on WIN SOURCE:

-  [View MAX77839BEFQ+T on WIN SOURCE](#)
-  [Analog Devices Inc. Information](#)

Optimize Your Supply Chain with WIN SOURCE Solutions

-  Global Sourcing Solution
-  Obsolete Management
-  Cost Control Management
-  Shortage Management
-  Alternative Solution
-  Excess Inventory Management