



**THE DATASHEET OF  
MAX20412ATJC/V+**



Click [here](#) for production status of specific part numbers.

## MAX20412

## Automotive Low-Voltage, 2-Channel Step-Down Controller

### General Description

The MAX20412 is a dual-output, high-efficiency, synchronous step-down controller IC that operates with a 3.0V to 5.5V input voltage range and provides a 0.25V to 1.275V output voltage range. The controller architecture enables up to 30A of load current per phase. Channel one has an option to operate with two phases to deliver higher load current, making this device ideal for automotive point-of-load (PoL) and post-regulation applications.

The IC achieves  $\pm 2\%$  output error over load, line, and temperature ranges. The IC features a 2.2MHz/1.1MHz fixed-frequency PWM mode for better noise immunity and load-transient response, and a pulse-frequency modulation mode (skip) for increased efficiency during light-load operation. The 2.2MHz frequency operation allows the use of all-ceramic capacitors and minimizes external components. The programmable spread-spectrum frequency modulation minimizes radiated electromagnetic emissions.

The MAX20412 is offered with factory-preset output voltages (see the [Selector Guide](#) for options). The I<sup>2</sup>C interface supports dynamic voltage adjustment with programmable slew rates for each channel. Other features include programmable soft-start, overcurrent, and over-temperature protections.

### Applications

- Automotive

### Benefits and Features

- 2-Channel, High-Efficiency DC-DC Controller in a Small Solution Size
  - 3.0V to 5.5V Operating Supply Voltage
  - OUT1 Supports 60A (with Two Phases)
  - OUT2 Supports 30A
- High-Precision Regulator for Applications Processors
  - $\pm 2\%$  Output-Voltage Accuracy
  - Differential Remote-Voltage Sensing
  - I<sup>2</sup>C-Controlled Output Voltage: 0.25V to 1.275V in 6.25mV Steps
  - Excellent Load-Transient Performance
  - Programmable Compensation
- Low-Noise Features Reduce EMI
  - 2.2MHz or 1.1MHz Operation
  - Spread-Spectrum Option
  - Frequency-Synchronization Input/Output
  - Current-Mode, Forced-PWM, and Skip Operation
- Robust for the Automotive Environment
  - Individual Enable Inputs and PGOOD Outputs
  - Low  $R_{DS(ON)}$  External MOSFETs
  - Overtemperature and Short-Circuit Protection
  - 32-Pin (5mm x 5mm) TQFN with Exposed Pad
  - $-40^{\circ}\text{C}$  to  $+125^{\circ}\text{C}$  Operating Temperature Range
  - AECQ-100 Qualified

[Ordering Information](#) appears at end of data sheet.

Typical Operating Circuit

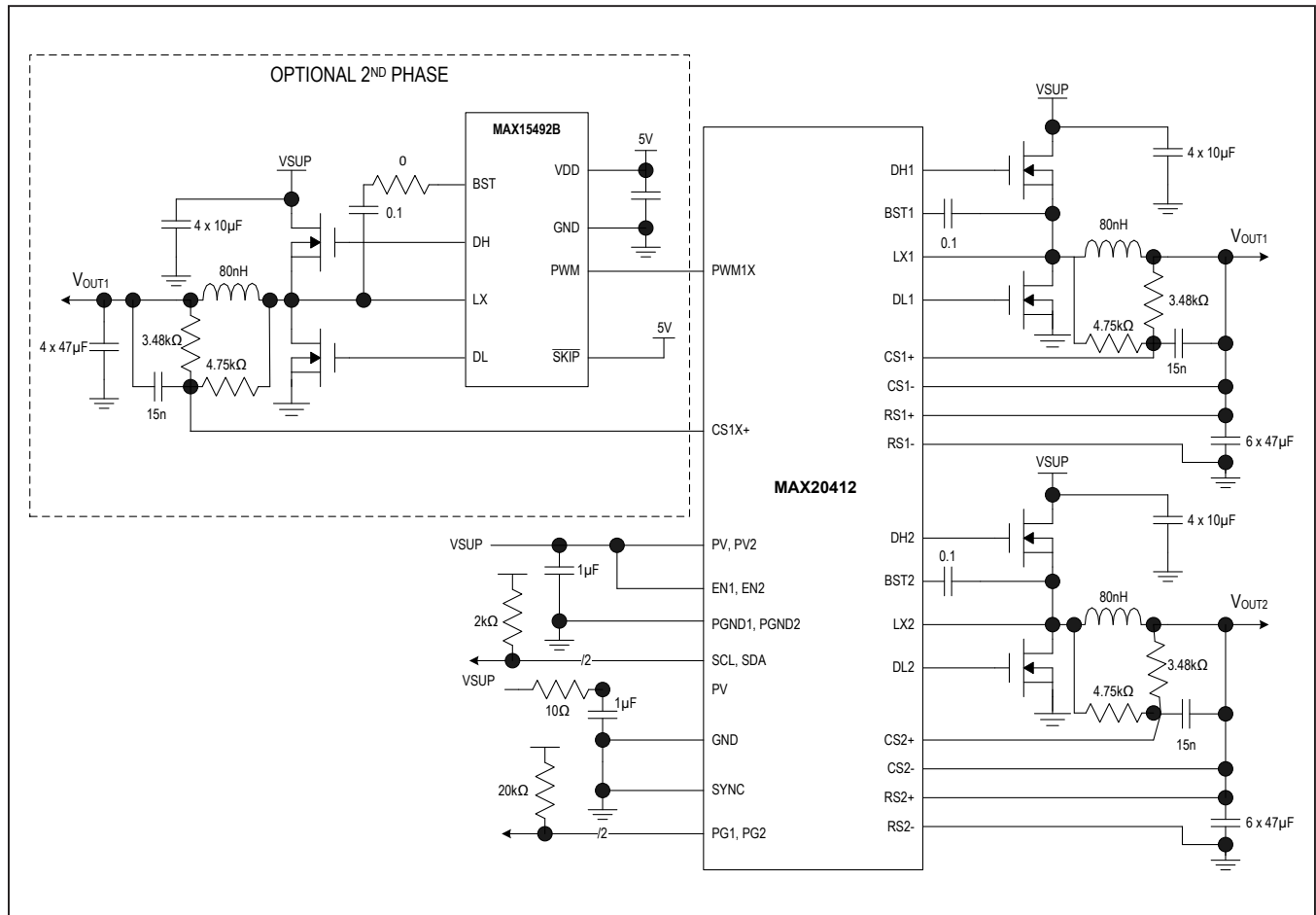

### Absolute Maximum Ratings

|                              |                      |  |                    |
|------------------------------|----------------------|--|--------------------|
| PV1, PV2 to PGND_            | -0.3V to +6V         | PWM1X to GND   | -0.3V to PV + 0.3V |
| PV to GND                    | -0.3V to +6V         | GND to PGND_   | -0.3V to +0.3V     |
| EN_, RS_+, RS_-, SYNC to GND | -0.3V to PV + 0.3V   | Output Short-Circuit Duration  | Continuous         |
| PG_, ADDR, SDA, SCL to GND   | -0.3V to +6V         | Continuous Power Dissipation (T <sub>A</sub> = +70°C) (Multilayer Board) |                    |
| DH_ to LX_                   | -0.3V to BST_ + 0.3V | 32-Pin TQFN (derate 34.5mW/°C above +70°C)                               | 2758.6mW           |
| DL_ to PGND_                 | -0.3V to PV_ + 0.3V  | Operating Temperature Range  | -40°C to +125°C    |
| BST_ to LX_                  | -0.3V to +6V         | Junction Temperature   | +150°C             |
| LX_ to PGND_                 | -2V to +6V           | Storage Temperature Range  | -65°C to +150°C    |
| CS1+ to CS1-, CS2+ to CS2-   | -0.3V to +0.3V       | Lead Temperature (soldering, 10s)  | +300°C             |
| CS_-, CS1X+ to GND           | -0.3V to PV + 0.3V   | Soldering Temperature (reflow)   | +260°C             |

Stresses beyond those listed under “Absolute Maximum Ratings” may cause permanent damage to the device. These are stress ratings only, and functional operation of the device at these or any other conditions beyond those indicated in the operational sections of the specifications is not implied. Exposure to absolute maximum rating conditions for extended periods may affect device reliability.

### Package Thermal Characteristics (Note 1)

32 TQFN

|   |        |
|---|--------|
| Junction-to-Ambient Thermal Resistance (θ <sub>JA</sub> ) | 36°C/W |
| Junction-to-Case Thermal Resistance (θ <sub>JC</sub> )    | 3°C/W  |

**Note 1:** Package thermal resistances were obtained using the method described in JEDEC specification JESD51-7, using a four-layer board. For detailed information on package thermal considerations, refer to [www.maximintegrated.com/thermal-tutorial](http://www.maximintegrated.com/thermal-tutorial).

### Package Information

For the latest package outline information and land patterns (footprints), go to [www.maximintegrated.com/packages](http://www.maximintegrated.com/packages). Note that a “+”, “#”, or “-” in the package code indicates RoHS status only. Package drawings may show a different suffix character, but the drawing pertains to the package regardless of RoHS status.

| PACKAGE TYPE | PACKAGE CODE | OUTLINE NO.             | LAND PATTERN NO.        |
|--------------|--------------|-------------------------|-------------------------|
| 32 TQFN-EP   | T3255+6C     | <a href="#">21-0140</a> | <a href="#">90-0603</a> |

### Electrical Characteristics

(V<sub>PV</sub> = V<sub>PV\_</sub> = 5V, T<sub>A</sub> = T<sub>J</sub> = -40°C to +125°C, unless otherwise noted. Typical values are at T<sub>A</sub> = +25°C under normal conditions, unless otherwise noted.) (Note 2)

| PARAMETER                  | SYMBOL                | CONDITIONS   | MIN | TYP  | MAX | UNITS |
|----------------------------|-----------------------|--|-----|------|-----|-------|
| Supply Voltage Range       | V <sub>IN</sub>       | Fully operational  | 3.0 |      | 5.5 | V     |
| UVLO                       | V <sub>IN_UVLO</sub>  | Rising   |     | 2.9  | 3   | V     |
|                            |                       | Falling  | 2.6 | 2.7  |     |       |
| UVLO Hysteresis            | V <sub>IN_UVLOH</sub> |  |     | 200  |     | mV    |
| Supply Current (Skip Mode) | I <sub>IN_1</sub>     | EN1 = high, EN2 = low, CS1X+ = V <sub>PV_</sub> (Note 3) |     | 570  |     | µA    |
|                            | I <sub>IN_2</sub>     | EN1 = EN2 = high, CS1X+ = V <sub>PV</sub> (Note 3)       |     | 1100 |     |       |
| Shutdown Supply Current    | I <sub>SHDN</sub>     | EN1 = EN2 = low  |     | 5    | 10  | µA    |
| PWM Switching Frequency    | f <sub>SW</sub>       | CONFIG.FSW = 0   | 2.0 | 2.2  | 2.4 | MHz   |
|                            | f <sub>SW11</sub>     | CONFIG.FSW = 1   | 1.0 | 1.1  | 1.2 |       |
| Spread Spectrum            | SS                    | CONFIG.SS = 1  |     | +3   |     | %     |

**Electrical Characteristics (continued)**

( $V_{PV} = V_{PV\_} = 5V$ ,  $T_A = T_J = -40^{\circ}C$  to  $+125^{\circ}C$ , unless otherwise noted. Typical values are at  $T_A = +25^{\circ}C$  under normal conditions, unless otherwise noted.) (Note 2)

| PARAMETER                         | SYMBOL          | CONDITIONS   | MIN | TYP | MAX | UNITS       |
|-----------------------------------|-----------------|--|-----|-----|-----|-------------|
| Voltage Accuracy                  | $V_{OUT\_}$     | $V_{CS\_} = 0$ to $0.8 \times V_{LIM}$ (Note 3),<br>$3.0V \leq V_{PV\_} \leq 5.5V$ , 0.80V to 1.275V | -2  |     | +2  | %           |
| Voltage Accuracy                  | $V_{OUT\_L}$    | $V_{CS\_} = 0$ to $0.8 \times V_{LIM}$ (Note 3),<br>$3.0V \leq V_{PV\_} \leq 5.5V$ , 0.25V to 0.79V  | -15 |     | +15 | mV          |
| High-Side Output Drive Resistance | $R_{HSD\_HS}$   | Rising   |     | 2.0 |     | $\Omega$    |
| High-Side Output Drive Resistance | $R_{HSD\_LS}$   | Falling  |     | 1.5 |     | $\Omega$    |
| Low-Side Output Drive Resistance  | $R_{LSD\_HS}$   | Rising   |     | 1.5 |     | $\Omega$    |
| Low-Side Output Drive Resistance  | $R_{LSD\_LS}$   | Falling  |     | 1.3 |     | $\Omega$    |
| Peak Current-Limit Threshold      | $V_{LIM1}$      | Measured across $V_{CS\_}$ , DCR gain = 16   | 69  | 71  | 74  | mV          |
|                                   |                 | Measured across $V_{CS\_}$ , DCR gain = 32   | 43  | 45  | 47  |             |
| Peak Current-Limit Threshold      | $V_{LIM2}$      | Measured across $V_{CS\_}$ , DCR gain = 32   | 35  | 37  | 39  | mV          |
| Peak Current-Limit Threshold      | $V_{LIM4}$      | Measured across $V_{CS\_}$ , DCR gain = 16   | 81  | 83  | 87  | mV          |
| Skip Current Threshold            | $V_{SKIP}$      | Measured across $V_{CS\_}$ (Note 3),<br>DCR gain = 32, 4 options                                     |     | 10  |     | mV          |
|                                   |                 |  |     | 8   |     |             |
|                                   |                 | Measured across $V_{CS\_}$ (Note 3),<br>DCR gain = 16, 4 options                                     |     | 6   |     |             |
|                                   |                 |  |     | 4   |     |             |
| Maximum Duty Cycle                | $DC_{MAX}$      | PWM mode   | 90  |     |     | %           |
| Minimum On-Time                   | $t_{MINON}$     |  |     | 35  |     | ns          |
| LX Leakage Current                | $I_{LKG\_LX}$   | $V_{IN} = 6V$ , LX = PGND or PV,<br>$T_A = +25^{\circ}C$   |     | 0.1 |     | $\mu A$     |
| OUT2 Phase Shift                  | $PH_{OUT2}$     | OUT1 in single phase   |     | 180 |     | Degrees     |
| CS_ - Pulldown Resistance         | $R_{CS\_PD}$    | $V_{EN\_} = 0V$  |     | 5   |     | $\Omega$    |
| <b>THERMAL OVERLOAD</b>           |                 |  |     |     |     |             |
| Thermal-Shutdown Temperature      | $T_{SHDN}$      | $T_J$ rising   |     | 165 |     | $^{\circ}C$ |
| Hysteresis                        | $T_{HYS\_SHDN}$ |  |     | 15  |     | $^{\circ}C$ |

**Electrical Characteristics (continued)**

( $V_{PV} = V_{PV\_} = 5V$ ,  $T_A = T_J = -40^{\circ}C$  to  $+125^{\circ}C$ , unless otherwise noted. Typical values are at  $T_A = +25^{\circ}C$  under normal conditions, unless otherwise noted.) (Note 2)

| PARAMETER                              | SYMBOL          | CONDITIONS  | MIN | TYP | MAX | UNITS     |
|--|-----------------|---|-----|-----|-----|-----------|
| <b>POWER GOOD</b>                      |                 |   |     |     |     |           |
| PG_ OV Threshold                       | $T_{HOVR}$      | Rising, percentage of nominal output, blanked during slewing  | 104 | 108 | 112 | %         |
| PG_ OV Threshold                       | $T_{HOVF}$      | Falling, percentage of nominal output, blanked during slewing | 102 | 108 | 111 | %         |
| PG_ UV Threshold                       | $T_{HUVR}$      | Rising, percentage of nominal output, blanked during slewing  | 88  | 92  | 96  | %         |
| PG_ UV Threshold                       | $T_{HUVF}$      | Falling, percentage of nominal output, blanked during slewing | 89  | 92  | 95  | %         |
| Active Timeout Period                  | $t_{HOLD}$      |   |     | 256 |     | Cycles    |
| UV/OV Propagation Delay                | $t_{FILT}$      |   |     | 5   |     | $\mu s$   |
| Output High-Leakage Current            | $I_{LKG\_PG}$   |   |     |     | 1   | $\mu A$   |
| PG_ Output Low Level                   | $V_{OL\_PG\_}$  | $3.0V \leq V_{PV} \leq 5.5V$ , sinking -2mA                   |     |     | 0.2 | V         |
| <b>DIGITAL INPUT (ADDR, EN_)</b>       |                 |   |     |     |     |           |
| Input High Level                       | $V_{IH}$        |   | 1.5 |     |     | V         |
| Input Low Level                        | $V_{IL}$        |   |     |     | 0.5 | V         |
| Input Hysteresis                       | $V_{IHYS}$      |   |     | 0.1 |     | V         |
| EN_ Input Leakage Current              | $I_{LKG\_EN\_}$ | $0V \leq V_{IN} \leq 5.5V$                                    |     | 1   |     | $\mu A$   |
| <b>PWM1X</b>                           |                 |   |     |     |     |           |
| Output High                            | $V_{OH\_PWM}$   | $V_{PV} = 5.0V$ , $I_{SOURCE} = 3mA$                          | 4.2 |     |     | V         |
| Output Low                             | $V_{OL\_PWM}$   | $I_{SINK} = 3mA$  |     |     | 0.4 | V         |
| <b>DIGITAL INPUT (SYNC)</b>            |                 |   |     |     |     |           |
| Input High Level                       | $V_{IH\_SYNC}$  |   | 1.8 |     |     | V         |
| Input Low Level                        | $V_{IL\_SYNC}$  |   |     |     | 0.4 | V         |
| SYNC Input Pulldown                    | $R_{PD\_SYNC}$  |   |     | 100 |     | $k\Omega$ |
| Sync Input Frequency Range             | $f_{SYNC}$      | CONFIG.FSW = 0  | 1.8 |     | 2.6 | MHz       |
| Sync Input Frequency Range             | $f_{SYNC11}$    | CONFIG.FSW = 1  | 0.9 |     | 1.3 | MHz       |
| <b>SYNC OUTPUT (CONFIG.SO[1:0]=10)</b> |                 |   |     |     |     |           |
| Output Low                             | $V_{OL\_SYNC}$  | $I_{SINK} = 3mA$  |     |     | 0.4 | V         |
| Output High                            | $V_{OH\_SYNC}$  | $V_{PV} = 5.0V$ , $I_{SOURCE} = 3mA$                          | 4.2 |     |     | V         |

**Electrical Characteristics (continued)**

( $V_{PV} = V_{PV-} = 5V$ ,  $T_A = T_J = -40^{\circ}C$  to  $+125^{\circ}C$ , unless otherwise noted. Typical values are at  $T_A = +25^{\circ}C$  under normal conditions, unless otherwise noted.) (Note 2)

| PARAMETER                       | SYMBOL          | CONDITIONS                 | MIN | TYP | MAX | UNITS   |
|---------------------------------|-----------------|----------------------------|-----|-----|-----|---------|
| <b>DIGITAL INPUT (SCL, SDA)</b> |                 |                            |     |     |     |         |
| Input High Level                | $V_{IH\_I2C}$   |                            | 1.2 |     |     | V       |
| Input Low Level                 | $V_{IL\_I2C}$   |                            |     |     | 0.5 | V       |
| Input Hysteresis                | $V_{IHYS\_I2C}$ |                            |     | 0.1 |     | V       |
| Input Leakage Current           | $I_{LKG\_I2C}$  | $0V \leq V_{IN} \leq 5.5V$ |     | 0.1 |     | $\mu A$ |
| <b>I<sup>2</sup>C INTERFACE</b> |                 |                            |     |     |     |         |
| Clock Frequency                 | $f_{SCL}$       |                            |     |     | 3.4 | MHz     |
| Setup Time, Repeated START      | $t_{SU:STA}$    | (Note 3)                   | 160 |     |     | ns      |
| Hold Time, Repeated START       | $t_{HD:STA}$    | (Note 3)                   | 160 |     |     | ns      |
| SCL Low Time                    | $t_{LOW}$       | (Note 3)                   | 160 |     |     | ns      |
| SCL High Time                   | $t_{HIGH}$      | (Note 3)                   | 60  |     |     | ns      |
| Data Setup Time                 | $t_{SU:DAT}$    | (Note 3)                   | 10  |     |     | ns      |
| Data Hold Time                  | $t_{HD:DAT}$    | (Note 3)                   | 0   |     | 70  | ns      |
| Setup Time for STOP Condition   | $t_{SU:STO}$    | (Note 3)                   | 160 |     |     | ns      |
| Spike Suppression               | $t_{SS\_I2C}$   |                            |     | 20  |     | ns      |
| SDA Output Low                  | $V_{OL\_SDA}$   | $I_{SINK} = 13mA$          |     |     | 0.4 | V       |

**Note 2:** All units are 100% production tested at  $+25^{\circ}C$ . All temperature limits are guaranteed by design.

**Note 3:**  $V_{CS-} = (V_{CS+}) - (V_{CS-})$ .

Typical Operating Characteristics

( $T_A = +25^\circ\text{C}$ , unless otherwise noted.)

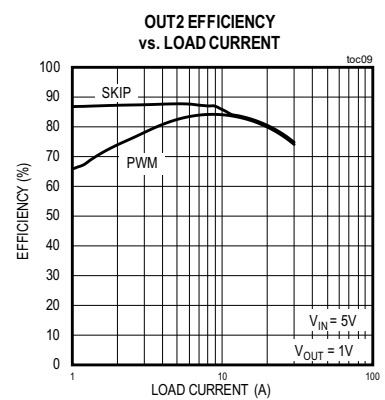
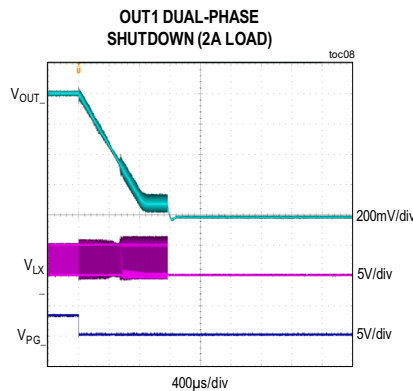
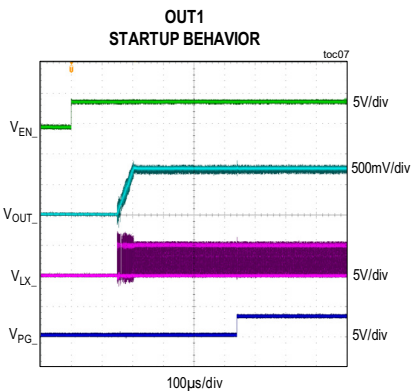
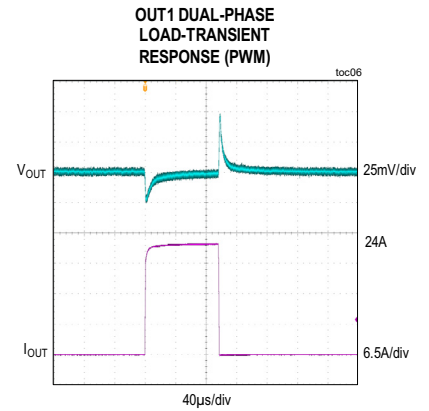
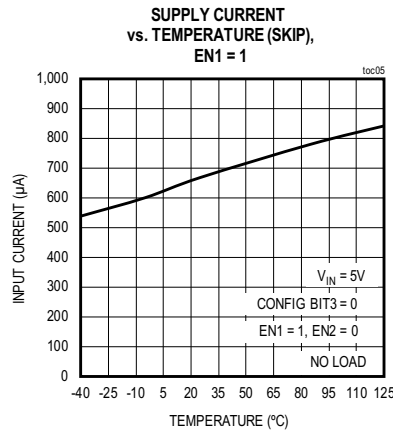
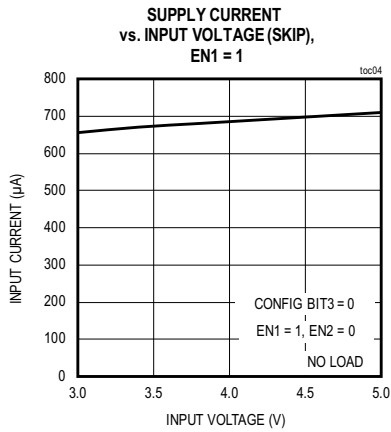
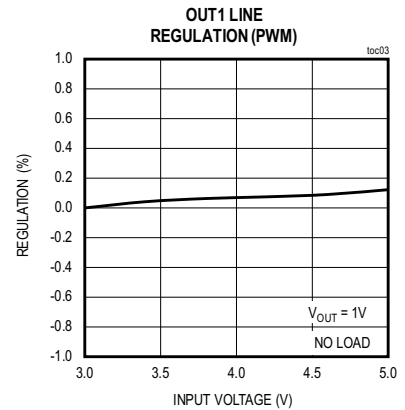
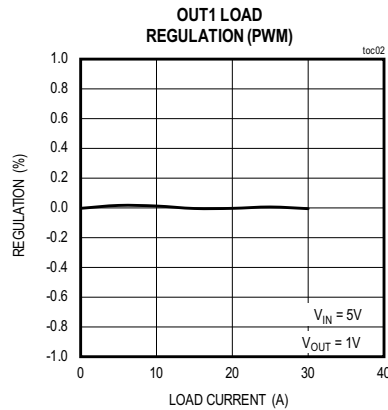
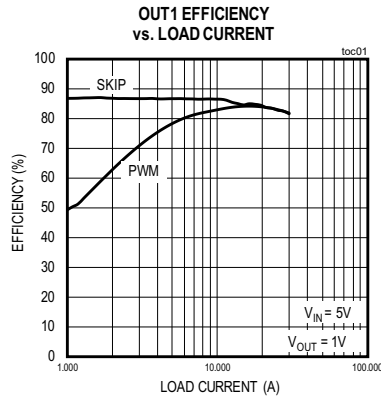

Typical Operating Characteristics

( $T_A = +25^\circ\text{C}$ , unless otherwise noted.)

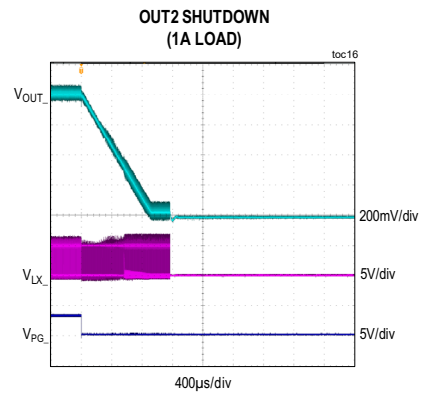
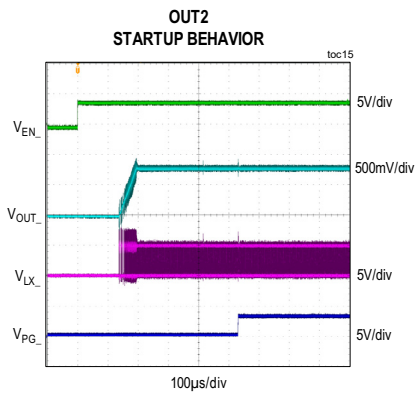
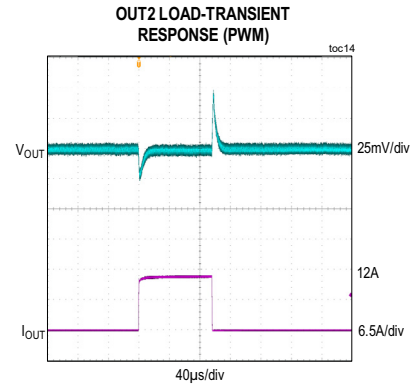
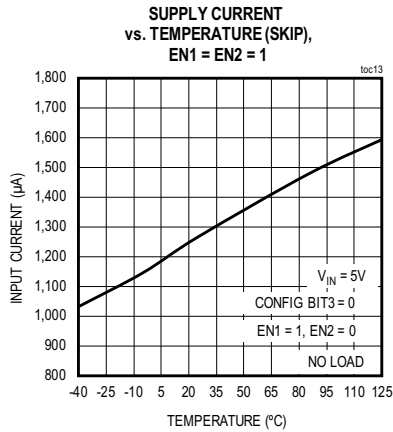
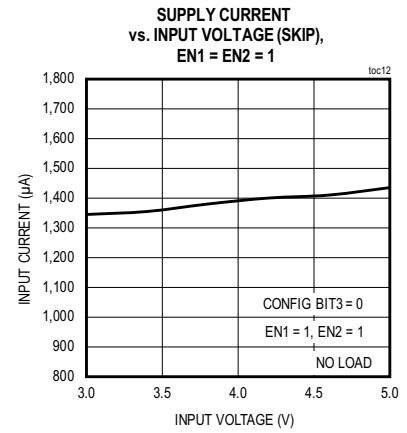
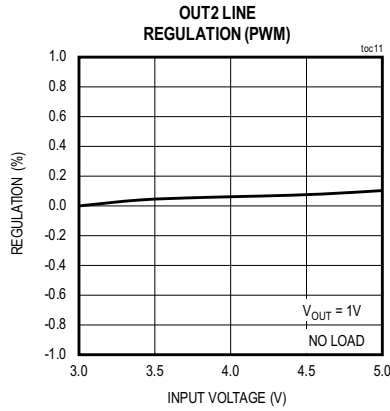
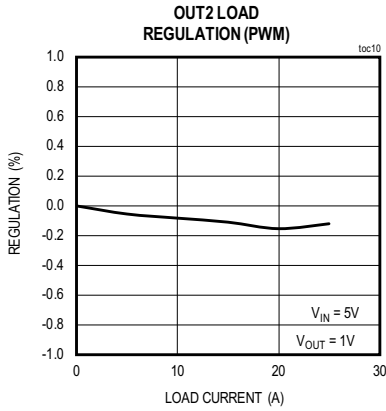

Typical Operating Characteristics

( $T_A = +25^\circ\text{C}$ , unless otherwise noted.)

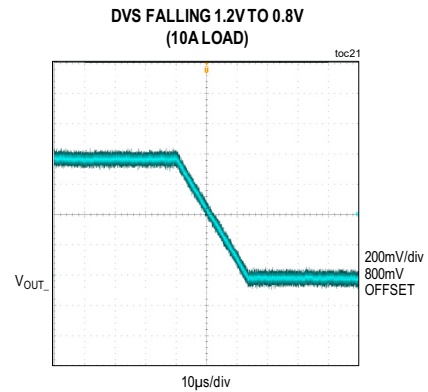
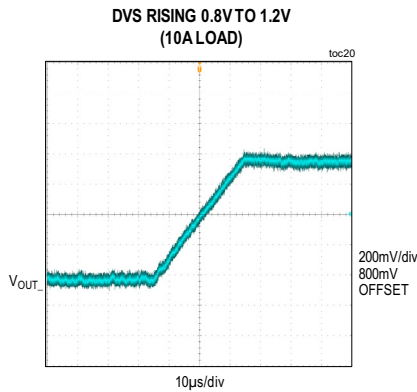
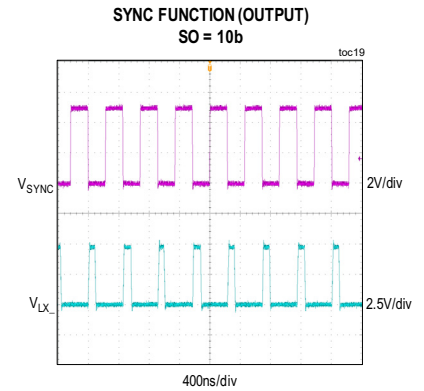
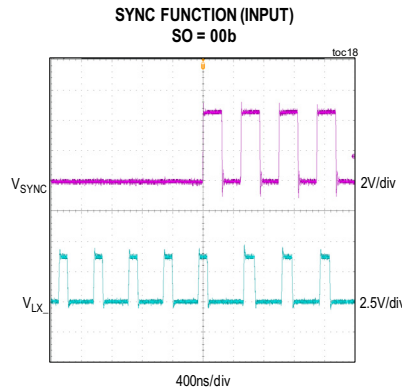
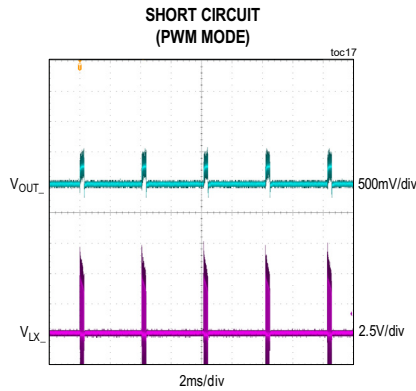

Pin Configuration

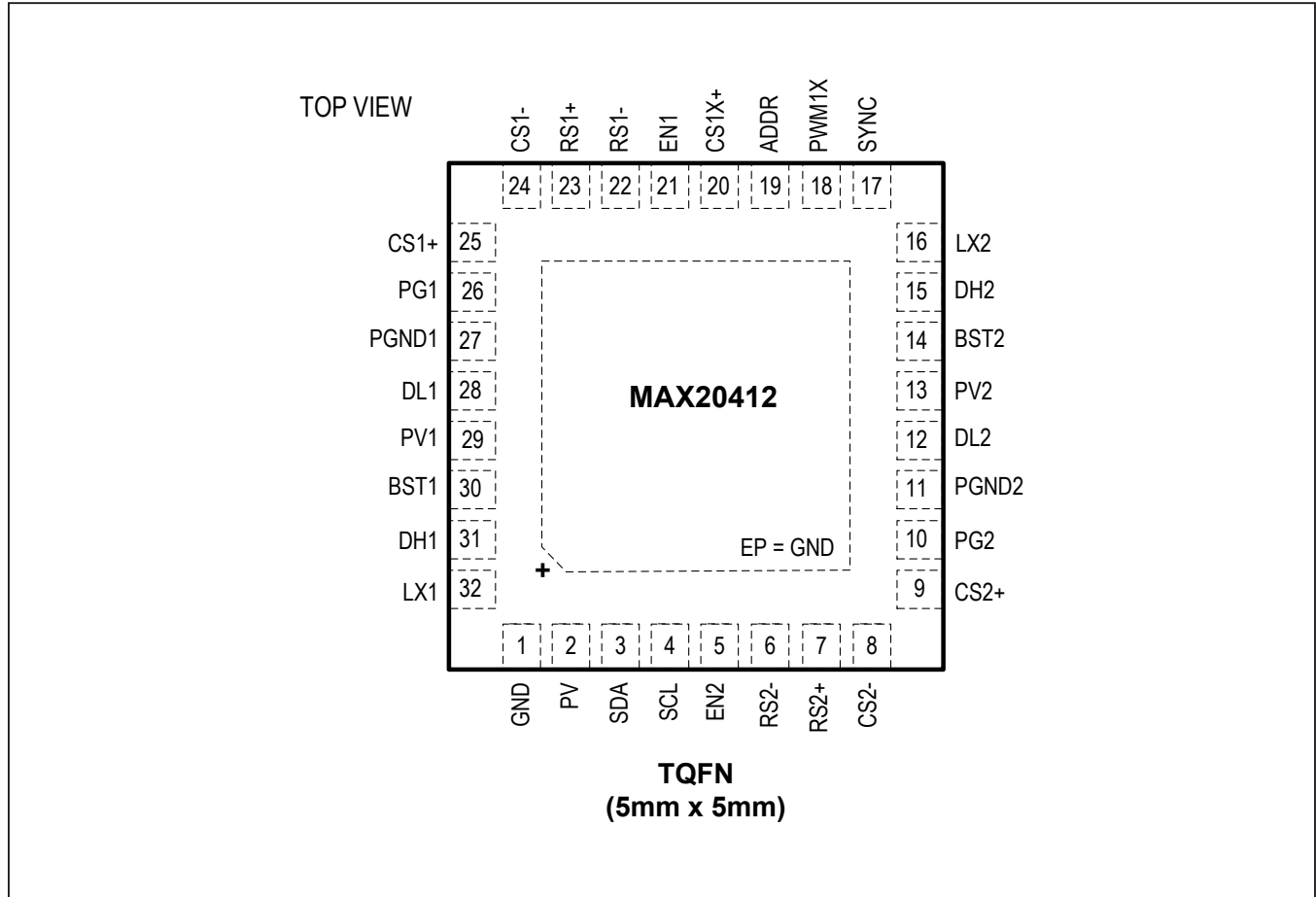

Pin Description

| PIN | NAME | FUNCTION  |
|-----|------|---|
| 1   | GND  | Analog Ground   |
| 2   | PV   | Analog Input Supply. Connect a 1µF ceramic capacitor from PV to GND. Connect PV to PV1 and PV2 through a 10Ω resistor.  |
| 3   | SDA  | I <sup>2</sup> C Data I/O   |
| 4   | SCL  | I <sup>2</sup> C Clock Input  |
| 5   | EN2  | Active-High Digital Enable Input for DCDC2. Drive EN2 high for normal operation. Connect EN2 to GND if DCDC2 is not used.   |
| 6   | RS2- | DCDC2 Remote Voltage-Sense Negative Input   |
| 7   | RS2+ | DCDC2 Remote Voltage-Sense Positive Input   |
| 8   | CS2- | Current-Sense Negative Input for DCDC2. Connect CS2- to the negative side of the current-sense element.   |
| 9   | CS2+ | Current-Sense Positive Input for DCDC2. Connect CS2+ to the positive side of the current-sense element. See the <a href="#">Current-Limit/Short-Circuit Protection</a> section. |

## Pin Description (continued)

| PIN | NAME  | FUNCTION   |
|-----|-------|--|
| 10  | PG2   | Open-Drain DCDC2 Reset Output. This output remains low for 120µs after the output has reached its regulation level (see the <a href="#">Electrical Characteristics</a> table). To obtain a logic signal, pull up PG2 with an external resistor.  |
| 11  | PGND2 | Power Ground for DCDC2   |
| 12  | DL2   | Low-Side Gate Drive for DCDC2  |
| 13  | PV2   | Input-Voltage Pin for DCDC2. Bypass this pin with enough input capacitance to supply current to the buck controller. Connect PV1 and PV2 together externally. See the <a href="#">Input Capacitor</a> section.   |
| 14  | BST2  | Bootstrap Capacitor for High-Side Driver of Buck 2. Connect a 0.1µF from LX2 to BST2.  |
| 15  | DH2   | High-Side Gate Drive for DCDC2   |
| 16  | LX2   | Inductor Connection for DCDC2. Connect LX2 to the switched side of the inductor. LX2 serves as the lower supply rail for the DH2 high-side gate driver.  |
| 17  | SYNC  | SYNC I/O. When configured as an input, connect SYNC to GND or leave unconnected to enable skip-mode operation under light loads. Connect SYNC to PV or an external clock to enable fixed-frequency, forced-PWM mode operation. When configured as an output, connect SYNC to other devices' SYNC inputs. |
| 18  | PWM1X | PWM Output for Optional Second Phase of DCDC1. Connect to the MAX15492 PWM pin. If unused, leave PWM1X unconnected.  |
| 19  | ADDR  | I <sup>2</sup> C Address Select. Connect to GND or PV to select between two different I <sup>2</sup> C addresses. See the <a href="#">Selector Guide</a> for default I <sup>2</sup> C settings.  |
| 20  | CS1X+ | Current-Sense Positive Input for the 2nd Phase of DCDC1. Connect CS1X+ to the positive side of the current-sense element. To disable phase 2, short CS1X+ to PV.   |
| 21  | EN1   | Active-High, Digital Enable Input for DCDC1. Drive EN1 high for normal operation. Connect EN1 to GND if DCDC1 is not used.   |
| 22  | RS1-  | DCDC1 Remote Voltage-Sense Negative Input  |
| 23  | RS1+  | DCDC1 Remote Voltage-Sense Positive Input  |
| 24  | CS1-  | Current-Sense Negative Input for DCDC1. Connect CS1- to the negative side of the current-sense element.  |
| 25  | CS1+  | Current-Sense Positive Input for DCDC1. Connect CS1+ to the positive side of the current-sense element. See the <a href="#">Current-Limit/Short-Circuit Protection</a> section.  |
| 26  | PG1   | Open-Drain DCDC1 Reset Output. This output remains low for 120µs after the output has reached its regulation level (see the <a href="#">Electrical Characteristics</a> table). To obtain a logic signal, pull up PG1 with an external resistor.  |
| 27  | PGND1 | Power Ground for DCDC1   |
| 28  | DL1   | Low-Side Gate Drive for DCDC1  |
| 29  | PV1   | Input-Voltage Pin for DCDC1. Bypass this pin with enough input capacitance to supply current to the buck controller. Connect PV1 and PV2 together externally. See the <a href="#">Input Capacitor</a> section.   |
| 30  | BST1  | Bootstrap Capacitor for High-Side Driver of DCDC1. Connect a 0.1µF from LX1 to BST1.   |
| 31  | DH1   | High-Side Gate Drive of DCDC1  |
| 32  | LX1   | Inductor Connection for DCDC1. Connect LX1 to the switched side of the inductor. LX1 serves as the lower supply rail for the DH1 high-side gate driver.  |
| —   | EP    | Exposed Pad. Connect EP to ground. Connecting the exposed pad to ground does not remove the requirement for proper ground connections to PGND1, PGND2, and GND. The exposed pad is attached with epoxy to the substrate of the die, making it an excellent path to remove heat from the IC.              |

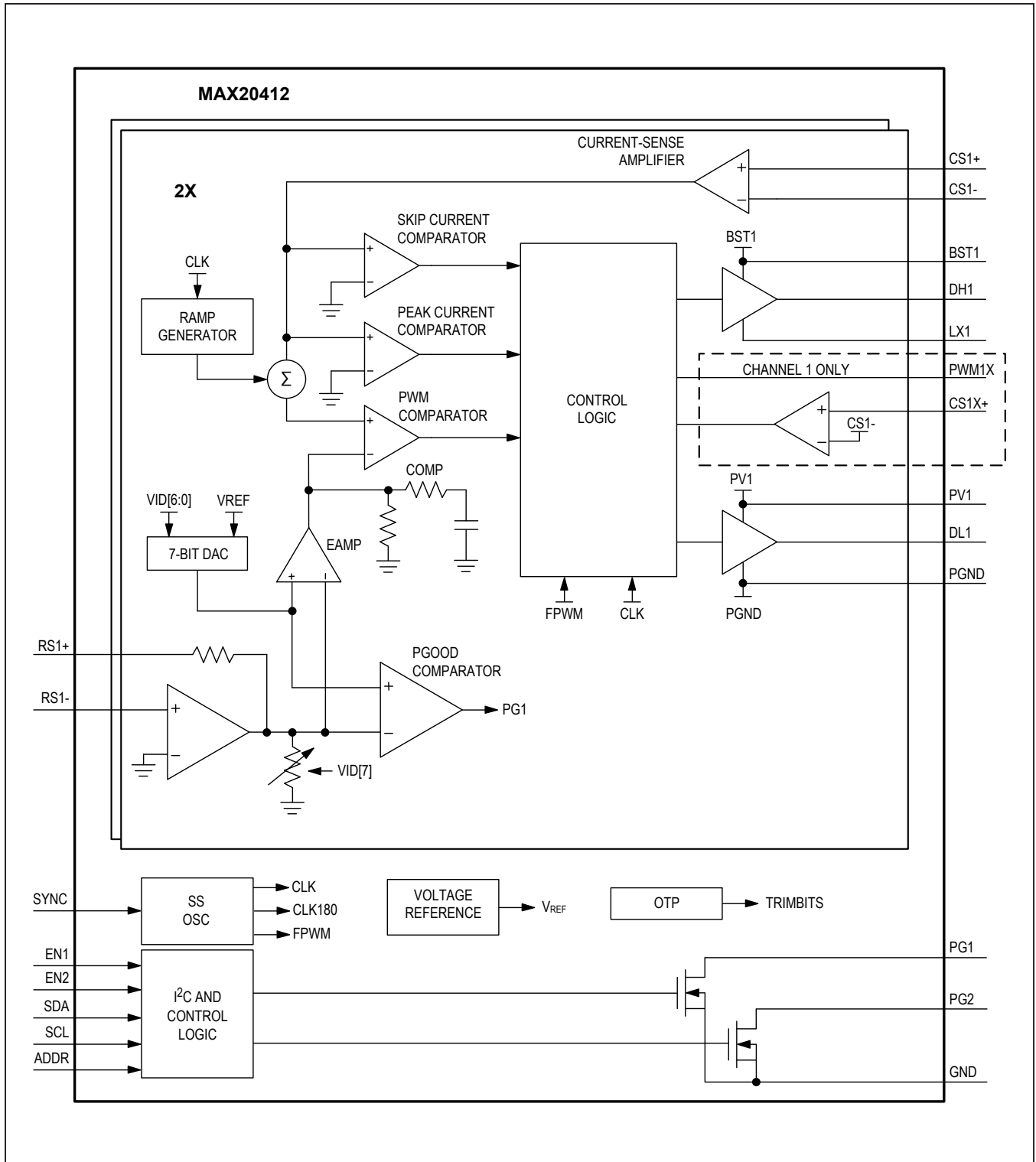

Figure 1. Internal Block Diagram

**Detailed Description**

The MAX20412 is a dual-output, high-efficiency synchronous step-down controller IC that operates with a 3.0V to 5.5V input voltage range and provides a 0.25V to 1.275V output voltage range. The IC delivers up to 30A of load current per channel and achieves  $\pm 2\%$  output error over load, line, and temperature ranges. The IC can operate as a 2-phase controller to deliver currents of up to 60A.

The PWM input forces the IC into either a 2.2MHz fixed-frequency PWM mode, or a low-power pulse-frequency modulation mode (skip). Optional spread-spectrum frequency modulation minimizes radiated electromagnetic emissions due to the switching frequency. The I<sup>2</sup>C-programmable synchronization I/O (SYNC) enables system synchronization.

The IC is offered with a factory-preset output voltage that is dynamically adjustable through the I<sup>2</sup>C interface. The output voltage can be set to any desired value between 0.25V and 1.275V.

Additional features include fixed power-good delay, adjustable soft-start and DVS rate, overcurrent, and overtemperature protections (Figure 1).

**I<sup>2</sup>C Interface**

The IC features an I<sup>2</sup>C, 2-wire serial interface consisting of a serial-data line (SDA) and a serial-clock line (SCL). SDA and SCL facilitate communication between the

IC and the master at clock rates up to 3.4MHz. The master, typically a microcontroller, generates SCL and initiates data transfer on the bus. Figure 2 shows the 2-wire interface timing diagram.

A master device communicates to the IC by transmitting the proper address followed by the data word. Each transmit sequence is framed by a START (S) or Repeated START (Sr) condition and a STOP (P) condition. Each word transmitted over the bus is 8 bits long and is always followed by an acknowledge clock pulse.

The IC's SDA line operates as both an input and an open-drain output. A pullup resistor greater than 500Ω is required on the SDA bus. The IC's SCL line operates as an input only. A pullup resistor greater than 500Ω is required on SCL if there are multiple masters on the bus, or if the master in a single-master system has an open-drain SCL output. Series resistors in line with SDA and SCL are optional. The SDA and SCL inputs suppress noise spikes to assure proper device operation, even on a noisy bus.

**Bit Transfer**

One data bit is transferred during each SCL cycle. The data on SDA must remain stable during the high period of the SCL pulse. Changes in SDA while SCL is high are control signals (see the STOP and START Conditions section). SDA and SCL idle high when the I<sup>2</sup>C bus is not busy.

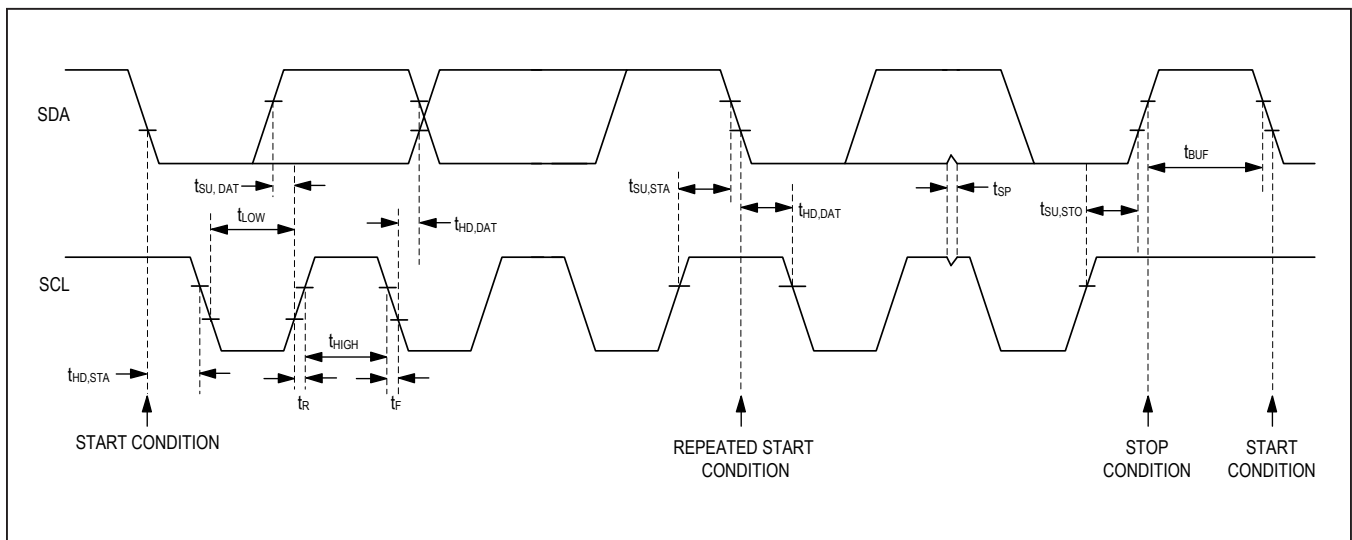

Figure 2. I<sup>2</sup>C Timing Diagram

**STOP and START Conditions**

A master device initiates communication by issuing a START condition. A START condition is a high-to-low transition on SDA with SCL high. A STOP condition is a low-to-high transition on SDA while SCL is high (Figure 3). A START (S) condition from the master signals the beginning of a transmission to the device. The master terminates transmission, and frees the bus, by issuing a STOP (P) condition. The bus remains active if a Repeated START (Sr) condition is generated instead of a STOP condition.

The device recognizes a STOP condition at any point during data transmission, unless the STOP condition occurs in the same high pulse as a START condition.

**Clock Stretching**

In general, the clock-signal generation for the I<sup>2</sup>C bus is the responsibility of the master device. The I<sup>2</sup>C specification allows slow slave devices to alter the clock signal by holding down the clock line. The process in which a slave device holds down the clock line is typically called clock stretching. The MAX20412 IC does not use any form of clock stretching to hold down the clock line.

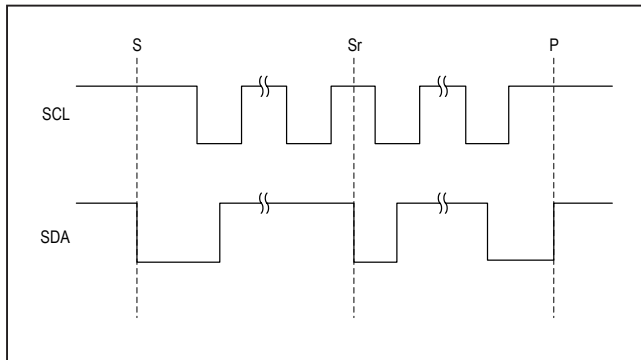

Figure 3. START, STOP, and Repeated START Conditions

**I<sup>2</sup>C General Call Address**

The IC does not implement the I<sup>2</sup>C specifications' "general call address." If the device sees the general call address (0b0000\_0000), it does not issue an acknowledge.

**Slave Address**

Once the device is enabled, the I<sup>2</sup>C slave address is set by the ADDR pin (Table 1). Each output channel has a unique slave address. The address is defined as the 7 most significant bits (MSBs), followed by the R/W bit. Set the R/W bit to 1 to configure the IC to read mode. Set the R/W bit to 0 to configure the IC to write mode. The address is the first byte of information sent to the devices after the START condition.

**Table 1. I<sup>2</sup>C Slave Addresses**

| ADDR PIN | A6 | A5 | A4 | A3 | A2* | A1* | A0 | WRITE | READ |
|----------|----|----|----|----|-----|-----|----|-------|------|
| 0        | 0  | 1  | 1  | 1  | 0   | 0   | 0  | 0x70  | 0x71 |
| 1        | 0  | 1  | 1  | 1  | 0   | 0   | 1  | 0x72  | 0x73 |
| 0        | 0  | 1  | 1  | 1  | 0   | 1   | 0  | 0x74  | 0x75 |
| 1        | 0  | 1  | 1  | 1  | 0   | 1   | 1  | 0x76  | 0x77 |
| 0        | 0  | 1  | 1  | 1  | 1   | 0   | 0  | 0x78  | 0x79 |
| 1        | 0  | 1  | 1  | 1  | 1   | 0   | 1  | 0x7A  | 0x7B |

\*See the [Selector Guide](#) for default settings.

**Acknowledge**

The acknowledge bit (ACK) is a clocked 9th bit that the device uses to handshake receipt each byte of data (Figure 4). The device pulls down SDA during the master-generated 9th clock pulse. The SDA line must remain stable and low during the high period of the acknowledge clock pulse. Monitoring ACK allows for detection of unsuccessful data transfers. An unsuccessful data transfer occurs if a receiving device is busy or if a system fault has occurred. In the event of an unsuccessful data transfer, the bus master can reattempt communication.

**Write Data Format**

A write to the device includes transmission of a START condition, the slave address with the write bit set to 0, one byte of data to the register address, one byte of data to the command register, and a STOP condition. Figure 5 illustrates the proper format for one frame.

**Read Data Format**

A read from the device includes transmission of a START condition, the slave address with the write bit set to 0, one byte of data to the register address, a restart condition, the slave address with the read bit set to 1, one byte of data to the command register, and a STOP condition. Figure 5 illustrates the proper format for one frame.

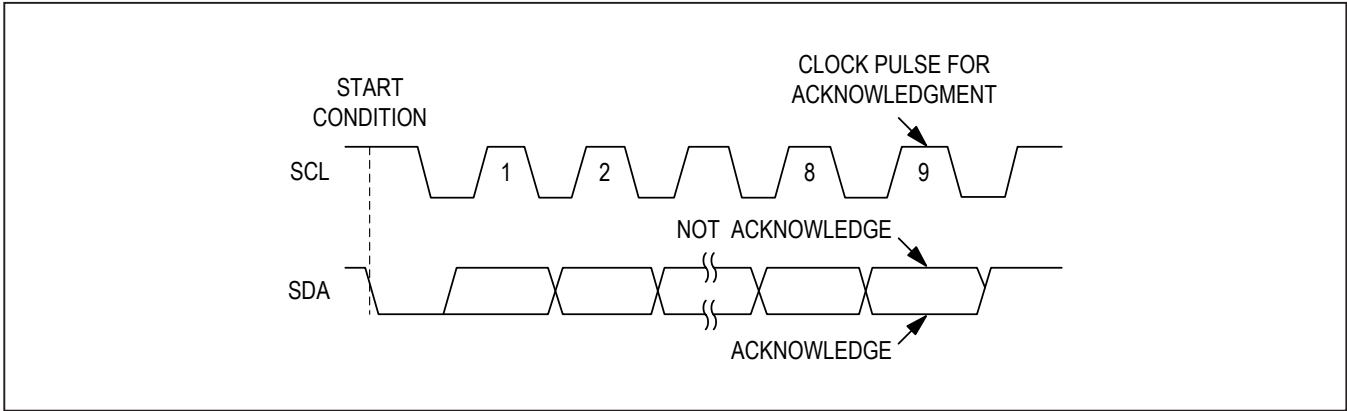

Figure 4. Acknowledge Condition

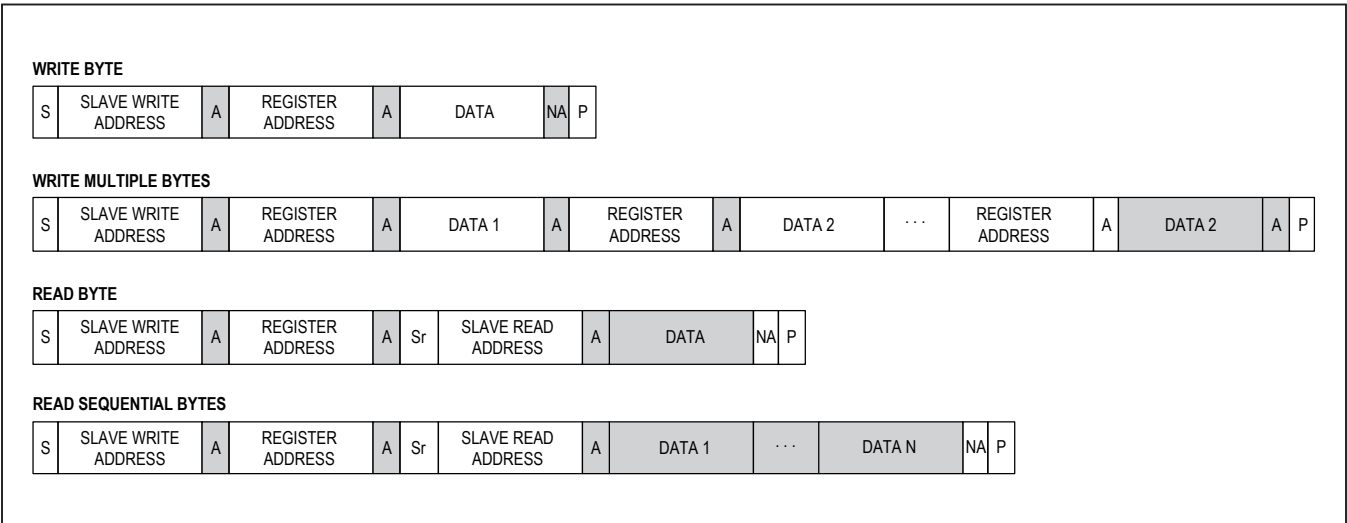

Figure 5. Data Format of I<sup>2</sup>C Interface

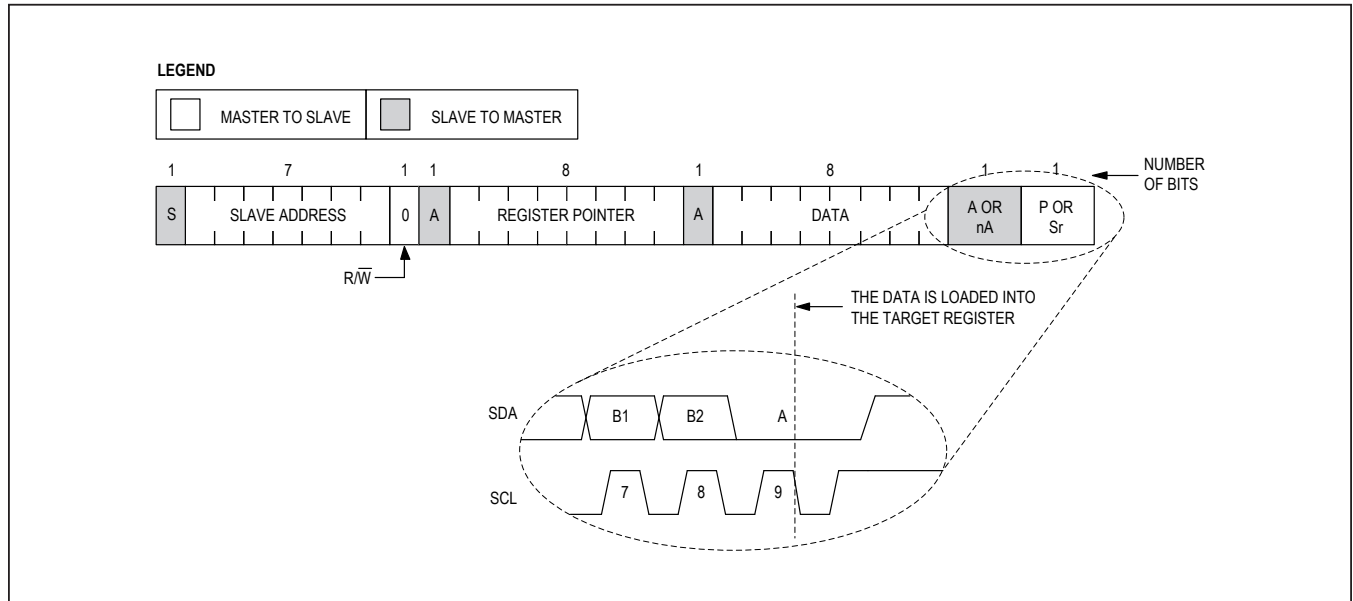

Figure 6. Write Byte Format

**Writing to a Single Register**

Figure 6 shows the protocol for the I<sup>2</sup>C master device to write one byte of data to the MAX20412. This protocol is the same as the SMBus specification’s “write byte” protocol.

The “write byte” protocol is as follows:

- 1) The master sends a START command (S).
- 2) The master sends the 7-bit slave address followed by a write bit ( $R/\overline{W} = 0$ ).
- 3) The addressed slave asserts an acknowledge (A) by pulling SDA low.
- 4) The master sends an 8-bit register pointer.
- 5) The slave acknowledges the register pointer.
- 6) The master sends a data byte.
- 7) The slave updates with the new data.
- 8) The slave acknowledges or not acknowledges the data byte. The next rising edge on SDA loads the data byte into its target register and the data becomes active.
- 9) The master sends a STOP condition (P) or a Repeated START condition (Sr).

**Writing Multiple Bytes Using Register Data Pairs**

Figure 7 shows the protocol for the I<sup>2</sup>C master device to write multiple bytes to the MAX20412 using register-data pairs. This protocol allows the I<sup>2</sup>C master device to address the slave only once and then send data to

multiple registers in a random order. Registers can be written continuously until the master issues a STOP condition.

The “writing multiple bytes using register-data pairs” protocol is not supported by the RTC functional block.

The “multiple byte register-data pair” protocol is as follows:

- 1) The master sends a START command.
- 2) The master sends the 7-bit slave address followed by a write bit.
- 3) The addressed slave asserts an acknowledge by pulling SDA low.
- 4) The master sends an 8-bit register pointer.
- 5) The slave acknowledges the register pointer.
- 6) The master sends a data byte.
- 7) The slave acknowledges the data byte. The next rising edge on SDA loads the data byte into its target register and the data becomes active.
- 8) Steps 4–7 are repeated as many times as the master requires.
- 9) The master sends a STOP condition. During the rising edge of the stop-related SDA edge, the data byte that was previously written is loaded into the target register and becomes active.

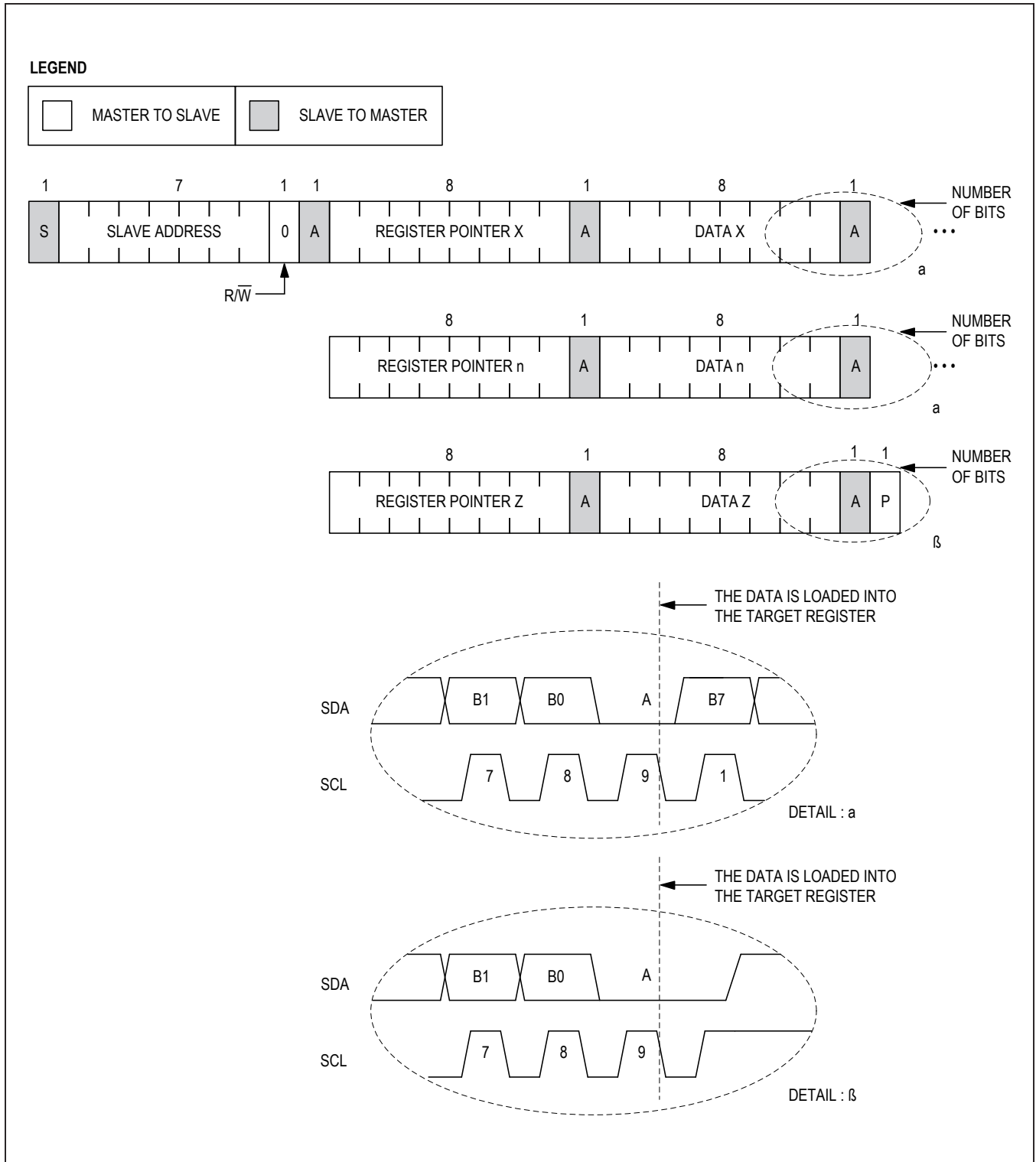

Figure 7. Write Register-Data-Pair Format

**Table 2. Register Map**

| REG     | BIT 7  | BIT 6   | BIT 5    | BIT 4    | BIT 3      | BIT 2    | BIT 1    | BIT 0    | CMD  | R/W | POWER-ON RESET |
|---------|--------|---------|----------|----------|------------|----------|----------|----------|------|-----|----------------|
| ID      | DEV3   | DEV2    | DEV1     | DEV0     | R3         | R2       | R1       | R0       | 0x00 | R   | 0x00           |
| —       | —      | —       | —        | —        | —          | —        | —        | —        | 0x01 | R/W | 0x00           |
| VIDMAX  | VMAX7  | VMAX6   | VMAX5    | VMAX4    | VMAX3      | VMAX2    | VMAX1    | VMAX0    | 0x02 | R/W | OTP            |
| CONFIG2 | VSKIP1 | VSKIP0  | Reserved | Reserved | Reserved   | Reserved | Reserved | Reserved | 0x03 | R/W | OTP            |
| STATUS  | INTERR | —       | VRHOT    | UV       | OV         | OC       | VMERR    | 0        | 0x04 | R   | 0x00           |
| CONFIG  | —      | FSW     | —        | —        | FPWM       | SS       | SO1      | SO0      | 0x05 | R/W | OTP            |
| SLEW    | —      | —       | —        | —        | SR3        | SR2      | SR1      | SR0      | 0x06 | R/W | OTP            |
| VID     | VID7   | VID6    | VID5     | VID4     | VID3       | VID2     | VID1     | VID0     | 0x07 | R/W | OTP            |
| COMP    | ZEN    | GM[1:0] |          | Z        | RCOMP[3:0] |          |          |          | 0x08 | R/W | OTP            |

**Note:** Both outputs have an identical register set, as defined below. They are accessed individually by using each channel's unique I<sup>2</sup>C address. Each channel has the

same register set accessed through their individual I<sup>2</sup>C address (see [Table 1](#)).

**Table 3. Identification Register (ID, 0x00)**

| ID       |      |      |      |      |    |    |    |    |
|----------|------|------|------|------|----|----|----|----|
| BIT NO.  | 7    | 6    | 5    | 4    | 3  | 2  | 1  | 0  |
| NAME     | DEV3 | DEV2 | DEV1 | DEV0 | R3 | R2 | R1 | R0 |
| OUT1 POR | 0    | 1    | 0    | 0    | 0  | 0  | 1  | 0  |
| OUT2 POR | 0    | 1    | 0    | 1    | 0  | 0  | 1  | 0  |

| BIT      | BIT DESCRIPTION   |
|----------|---|
| DEV[3:0] | <b>Device ID:</b><br>MAX20412 OUT1 = 0x4<br>MAX20412 OUT2 = 0x5 |
| R[3:0]   | MAX20412 Pass 3 = 0x2   |

**Table 4. Maximum Voltage-Settings Registers (VIDMAX, 0x02)**

| VIDMAX  |       |       |       |       |       |       |       |       |
|---------|-------|-------|-------|-------|-------|-------|-------|-------|
| BIT NO. | 7     | 6     | 5     | 4     | 3     | 2     | 1     | 0     |
| NAME    | VMAX7 | VMAX6 | VMAX5 | VMAX4 | VMAX3 | VMAX2 | VMAX1 | VMAX0 |
| POR     | OTP   | OTP   | OTP   | OTP   | OTP   | OTP   | OTP   | OTP   |

| BIT       | BIT DESCRIPTION  |
|-----------|--|
| VMAX[7:0] | <b>Maximum Voltage Setting:</b> If VID[] > VMAX[], then a fault is set and the actual voltage is capped by VMAX[]. See <a href="#">Table 10</a> for VID output-voltage selections. |

**Table 5. Configuration Register (CONFIG2, 0x03)**

| CONFIG2 |            |     |          |   |   |   |   |   |
|---------|------------|-----|----------|---|---|---|---|---|
| BIT NO. | 7          | 6   | 5        | 4 | 3 | 2 | 1 | 0 |
| NAME    | VSKIP[1:0] |     | RESERVED |   |   |   |   |   |
| POR     | OTP        | OTP | 0        | 1 | 0 | 0 | 0 | 0 |

| BIT          | BIT DESCRIPTION   |
|--------------|---|
| VSKIP[1:0]   | <b>Skip Current-Limit Configuration:</b><br>00 = 4A<br>01 = 6A<br>10 = 8A<br>11 = 10A |
| CONFIG2[5:0] | Reserved  |

**Table 6. Status Register (STATUS, 0x04)**

| STATUS  |        |   |       |    |    |    |       |   |
|---------|--------|---|-------|----|----|----|-------|---|
| BIT NO. | 7      | 6 | 5     | 4  | 3  | 2  | 1     | 0 |
| NAME    | INTERR | — | VRHOT | UV | OV | OC | VMERR | 0 |
| POR     | 0      | 0 | 0     | 0  | 0  | 0  | 0     | 0 |

| BIT    | BIT DESCRIPTION   |
|--------|---|
| INTERR | <b>Internal Hardware Error:</b> This bit is set to '1' when ATE trimming and testing is not complete.   |
| VRHOT  | <b>Thermal-Shutdown Indication:</b> A thermal shutdown has occurred since the last time this register was read.                               |
| UV     | <b>V<sub>OUT</sub> Undervoltage:</b> This bit indicates if the output is currently under the target voltage.                                  |
| OV     | <b>V<sub>OUT</sub> Overvoltage:</b> This bit indicates if the output is currently over the target voltage.                                    |
| OC     | <b>V<sub>OUT</sub> Overcurrent:</b> This bit indicates if an overcurrent event has occurred since the last time the STATUS register was read. |
| VMERR  | V <sub>OUT_MAX</sub> Error. Set to 1 if VID[] > VOUTMAX[].  |

**Table 7. Configuration Register (CONFIG, 0x05)**

| CONFIG  |     |     |     |     |      |     |     |     |
|---------|-----|-----|-----|-----|------|-----|-----|-----|
| BIT NO. | 7   | 6   | 5   | 4   | 3    | 2   | 1   | 0   |
| NAME    | —   | FSW | —   | —   | FPWM | SS  | SO1 | SO0 |
| POR     | OTP | OTP | OTP | OTP | OTP  | OTP | OTP | OTP |

| BIT     | BIT DESCRIPTION   |
|---------|---|
| FSW     | <b>Switching Frequency (sets the nominal switching frequency):</b><br>0 = 2.2MHz<br>1 = 1.1MHz  |
| FPWM    | <b>Forced-PWM Mode:</b><br>0 = Mode controlled by SYNC pin. When SYNC is output, the device is always in FPWM mode.<br>1 = Forced-PWM Mode. Overrides the SYNC skip-mode setting when SYNC is an input. |
| SS      | <b>Spread-Spectrum Clock Setting:</b><br>0 = Disabled<br>1 = +3% spread   |
| SO[1:0] | <b>SYNC I/O Select:</b><br>00 = Master: Input, rising edge starts cycle<br>01 = Master: Input, falling edge starts cycle<br>10 = Master: Output, falling edge starts cycle<br>11 = Unused               |

**Table 8. Slew-Rate Register (SLEW, 0x06)**

| SLEW    |     |     |     |     |     |     |     |     |
|---------|-----|-----|-----|-----|-----|-----|-----|-----|
| BIT NO. | 7   | 6   | 5   | 4   | 3   | 2   | 1   | 0   |
| NAME    | —   | —   | —   | —   | SR3 | SR2 | SR1 | SR0 |
| POR     | OTP | OTP | OTP | OTP | OTP | OTP | OTP | OTP |

| SR[3:0]             | SOFT-START SLEW RATE (mV/μs) | DVS SLEW RATE (mV/μs) |
|---------------------|------------------------------|-----------------------|
| XXXX0000            | 14                           | 14                    |
| XXXX0001            | 7                            | 14                    |
| XXXX0010            | 3.4                          | 14                    |
| XXXX0011            | 7                            | 7                     |
| XXXX0100            | 3.4                          | 7                     |
| XXXX0101            | 14                           | 14                    |
| XXXX0110            | 14                           | 14                    |
| XXXX0111            | 7                            | 14                    |
| XXXX1000            | 3.4                          | 14                    |
| XXXX1001            | 3.4                          | 3.4                   |
| XXXX1010 – XXXX1111 | Reserved                     | Reserved              |

**Note:** Falling DVS and power-down slew rate is -0.875mV/us.

**Table 9. Output-Voltage Register (VID, 0x07)**

| VID     |      |      |      |      |      |      |      |      |
|---------|------|------|------|------|------|------|------|------|
| BIT NO. | 7    | 6    | 5    | 4    | 3    | 2    | 1    | 0    |
| NAME    | VID7 | VID6 | VID5 | VID4 | VID3 | VID2 | VID1 | VID0 |
| POR     | OTP  | OTP  | OTP  | OTP  | OTP  | OTP  | OTP  | OTP  |

| BIT      | BIT DESCRIPTION  |
|----------|--|
| VID[7:0] | <b>Target Voltage Setting:</b> V <sub>OUT</sub> ramps at the programmed DVS ramp rate until it reaches programmed the VID. See <a href="#">Table 10</a> for VID output-voltage selections. When VID[7:0] ≠ 0, V <sub>OUT</sub> = (VID[7:0] + 39) x 0.00625V. |

Table 10. VID Output-Voltage Selection

| VID  | VOUT    | VID  | VOUT    | VID  | VOUT    | VID  | VOUT    | VID  | VOUT    | VID  | VOUT    |
|------|---------|------|---------|------|---------|------|---------|------|---------|------|---------|
| 0x00 | OFF     | 0x20 | 0.44375 | 0x40 | 0.64375 | 0x60 | 0.84375 | 0x80 | 1.04375 | 0xA0 | 1.24375 |
| 0x01 | 0.25000 | 0x21 | 0.45000 | 0x41 | 0.65000 | 0x61 | 0.85000 | 0x81 | 1.05000 | 0xA1 | 1.25000 |
| 0x02 | 0.25625 | 0x22 | 0.45625 | 0x42 | 0.65625 | 0x62 | 0.85625 | 0x82 | 1.05625 | 0xA2 | 1.25625 |
| 0x03 | 0.26250 | 0x23 | 0.46250 | 0x43 | 0.66250 | 0x63 | 0.86250 | 0x83 | 1.06250 | 0xA3 | 1.26250 |
| 0x04 | 0.26875 | 0x24 | 0.46875 | 0x44 | 0.66875 | 0x64 | 0.86875 | 0x84 | 1.06875 | 0xA4 | 1.26875 |
| 0x05 | 0.27500 | 0x25 | 0.47500 | 0x45 | 0.67500 | 0x65 | 0.87500 | 0x85 | 1.07500 | 0xA5 | 1.27500 |
| 0x06 | 0.28125 | 0x26 | 0.48125 | 0x46 | 0.68125 | 0x66 | 0.88125 | 0x86 | 1.08125 | —    | —       |
| 0x07 | 0.28750 | 0x27 | 0.48750 | 0x47 | 0.68750 | 0x67 | 0.88750 | 0x87 | 1.08750 | —    | —       |
| 0x08 | 0.29375 | 0x28 | 0.49375 | 0x48 | 0.69375 | 0x68 | 0.89375 | 0x88 | 1.09375 | —    | —       |
| 0x09 | 0.30000 | 0x29 | 0.50000 | 0x49 | 0.70000 | 0x69 | 0.90000 | 0x89 | 1.10000 | —    | —       |
| 0x0A | 0.30625 | 0x2A | 0.50625 | 0x4A | 0.70625 | 0x6A | 0.90625 | 0x8A | 1.10625 | —    | —       |
| 0x0B | 0.31250 | 0x2B | 0.51250 | 0x4B | 0.71250 | 0x6B | 0.91250 | 0x8B | 1.11250 | —    | —       |
| 0x0C | 0.31875 | 0x2C | 0.51875 | 0x4C | 0.71875 | 0x6C | 0.91875 | 0x8C | 1.11875 | —    | —       |
| 0x0D | 0.32500 | 0x2D | 0.52500 | 0x4D | 0.72500 | 0x6D | 0.92500 | 0x8D | 1.12500 | —    | —       |
| 0x0E | 0.33125 | 0x2E | 0.53125 | 0x4E | 0.73125 | 0x6E | 0.93125 | 0x8E | 1.13125 | —    | —       |
| 0x0F | 0.33750 | 0x2F | 0.53750 | 0x4F | 0.73750 | 0x6F | 0.93750 | 0x8F | 1.13750 | —    | —       |
| 0x10 | 0.34375 | 0x30 | 0.54375 | 0x50 | 0.74375 | 0x70 | 0.94375 | 0x90 | 1.14375 | —    | —       |
| 0x11 | 0.35000 | 0x31 | 0.55000 | 0x51 | 0.75000 | 0x71 | 0.95000 | 0x91 | 1.15000 | —    | —       |
| 0x12 | 0.35625 | 0x32 | 0.55625 | 0x52 | 0.75625 | 0x72 | 0.95625 | 0x92 | 1.15625 | —    | —       |
| 0x13 | 0.36250 | 0x33 | 0.56250 | 0x53 | 0.76250 | 0x73 | 0.96250 | 0x93 | 1.16250 | —    | —       |
| 0x14 | 0.36875 | 0x34 | 0.56875 | 0x54 | 0.76875 | 0x74 | 0.96875 | 0x94 | 1.16875 | —    | —       |
| 0x15 | 0.37500 | 0x35 | 0.57500 | 0x55 | 0.77500 | 0x75 | 0.97500 | 0x95 | 1.17500 | —    | —       |
| 0x16 | 0.38125 | 0x36 | 0.58125 | 0x56 | 0.78125 | 0x76 | 0.98125 | 0x96 | 1.18125 | —    | —       |
| 0x17 | 0.38750 | 0x37 | 0.58750 | 0x57 | 0.78750 | 0x77 | 0.98750 | 0x97 | 1.18750 | —    | —       |
| 0x18 | 0.39375 | 0x38 | 0.59375 | 0x58 | 0.79375 | 0x78 | 0.99375 | 0x98 | 1.19375 | —    | —       |
| 0x19 | 0.40000 | 0x39 | 0.60000 | 0x59 | 0.80000 | 0x79 | 1.00000 | 0x99 | 1.20000 | —    | —       |
| 0x1A | 0.40625 | 0x3A | 0.60625 | 0x5A | 0.80625 | 0x7A | 1.00625 | 0x9A | 1.20625 | —    | —       |
| 0x1B | 0.41250 | 0x3B | 0.61250 | 0x5B | 0.81250 | 0x7B | 1.01250 | 0x9B | 1.21250 | —    | —       |
| 0x1C | 0.41875 | 0x3C | 0.61875 | 0x5C | 0.81875 | 0x7C | 1.01875 | 0x9C | 1.21875 | —    | —       |
| 0x1D | 0.42500 | 0x3D | 0.62500 | 0x5D | 0.82500 | 0x7D | 1.02500 | 0x9D | 1.22500 | —    | —       |
| 0x1E | 0.43125 | 0x3E | 0.63125 | 0x5E | 0.83125 | 0x7E | 1.03125 | 0x9E | 1.23125 | —    | —       |
| 0x1F | 0.43750 | 0x3F | 0.63750 | 0x5F | 0.83750 | 0x7F | 1.03750 | 0x9F | 1.23750 | —    | —       |

**Table 11. Compensation Register (COMP, 0x08)**

| COMP    |     |         |     |     |            |     |     |     |
|---------|-----|---------|-----|-----|------------|-----|-----|-----|
| BIT NO. | 7   | 6       | 5   | 4   | 3          | 2   | 1   | 0   |
| NAME    | ZEN | GM[1:0] |     | Z   | RCOMP[3:0] |     |     |     |
| POR     | OTP | OTP     | OTP | OTP | OTP        | OTP | OTP | OTP |

| BIT        | BIT DESCRIPTION  |
|------------|--|
| ZEN        | <b>Zero Enable:</b><br>0 = Disable feed-forward zero<br>1 = Enable feed-forward zero   |
| GM[1:0]    | <b>Feed-Forward GM Selection to Set Zero Position:</b><br>00 = 100 $\mu$ S<br>01 = 188 $\mu$ S<br>10 = 265 $\mu$ S<br>11 = 335 $\mu$ S   |
| Z          | <b>Feed-Forward Zero Adjustment:</b><br>0 = 300k $\Omega$ : Zero at lower frequency<br>1 = 80k $\Omega$ : Zero at higher frequency   |
| RCOMP[3:0] | <b>Compensation-Resistor Selection:</b><br>0 = 70k $\Omega$<br>1 = 105k $\Omega$<br>2 = 140k $\Omega$<br>3 = 175k $\Omega$<br>4 = 210k $\Omega$<br>5 = 245k $\Omega$<br>6 = 280k $\Omega$<br>7 = 315k $\Omega$<br>8 = 30k $\Omega$<br>9 = 65k $\Omega$<br>10 = 105k $\Omega$<br>11 = 140k $\Omega$<br>12 = 170k $\Omega$<br>13 = 205k $\Omega$<br>14 = 240k $\Omega$<br>15 = 310k $\Omega$ |

**PG Output**

The IC features an open-drain PGOOD output that asserts when the output voltage is between the PG\_UV and PG\_OV thresholds. PG\_ is asserted after the power-good active-timeout period. An additional 220 $\mu$ s (typ) PG\_ delay exists following soft-start or DVS slewing. PG\_ is deasserted after a UV/OV propagation delay if the output voltage is outside the PG\_ UV/OV thresholds. Connect PG\_ to a pullup supply with a 20k $\Omega$  resistor.

**Soft-Start**

The IC includes a programmable soft-start rate. Soft-start limits startup inrush current by forcing the output voltage to ramp up towards its regulation point.

**Dynamic Voltage Scaling**

The step-down regulators feature dynamic voltage scaling (DVS) to allow loads to margin their supply voltage. DVS registers for OUT1 and OUT2 are programmed with VID[6:0]. The slew rate during DVS is adjustable with SR[3:0] (see [Table 8](#)). The PG\_ comparator is masked to prevent false PG\_ interrupts during the DVS period. I<sup>2</sup>C DVS commands should only be issued when the output voltage is no longer slewing and is in a stable state.

**Shutdown**

During shutdown, the output voltage is ramped down at the 0.875mV/ $\mu$ s slew rate. The CS- pulldown is enabled as needed to assist in the ramp down. When powering down in skip mode under light load, the falling ramp may be based on the RC discharge curve based on C<sub>OUT</sub> and the 5 $\Omega$  pulldown resistance.

**Spread-Spectrum Option**

The IC features spread-spectrum (SS) operation by varying the internal operating frequency down by 3%, relative to the internally generated operating frequency of 2.2MHz (typ). This function does not apply to external sync.

**Synchronization (SYNC)**

SYNC is an I<sup>2</sup>C-programmable I/O. When configured as an input and the FPWM bit = 0, driving SYNC low or unconnected places the converter in skip mode. Forcing SYNC logic-high places the IC in forced-PWM (FPWM) mode. Input triggering on the rising edge or falling edge is determined by the setting of registers SO[1:0], see [Table 7](#). When SO[1:0] = 2, SYNC is configured as an output. The output clock is 180° out-of-phase with the internal clock.

**Current-Limit/Short-Circuit Protection**

The current-limit circuit uses differential current-sense inputs (CS\_+ and CS\_-) to limit the peak inductor current. If the magnitude of the current-sense signal exceeds the current-limit threshold (VLIM\_ = 45mV (typ)), the PWM controller turns off the high-side MOSFET.

The high side turns on again once the inductor current drops below the valley current limit. The actual maximum load current is less than the peak current-limit threshold by an amount equal to half the inductor ripple current. Therefore, the maximum load capability is a function of the current-sense resistance, inductor value, switching frequency, and duty cycle (V<sub>OUT</sub>/V<sub>IN</sub>). See [Figure 8](#) for current-sense configurations.

If the inductor current exceeds the maximum current limit programmed at CS\_+ and CS\_-, the respective driver turns off. In an overcurrent mode, this results in shorter and shorter high-side pulses. A hard short results in a minimum on-time pulse every clock cycle. During a hard short, the IC turns off and repeats soft-start every 4ms (at 2.2MHz switching frequency) until the short is removed. For an example, see the short-circuit (PWM mode) waveform (TOC20) in the [Typical Operating Characteristics](#) section.

**PWM/Skip Modes**

The IC features a SYNC input that puts both converters either in skip mode or forced-PWM mode of operation. See the [Pin Description](#) table for mode details. In PWM mode of operation, the converter switches at a constant frequency with variable on-time. In skip mode of operation, the converter's switching frequency is load-dependent until the output load reaches a certain threshold. At higher load current, the switching frequency does not change and the operating mode is similar to the PWM mode. Skip mode helps improve efficiency in light-load applications by allowing the converter to turn on the high-side switch only when the output voltage falls below a set threshold. As such, the converter does not switch MOSFETs on and off as often is the case in PWM mode. Consequently, the gate charge and switching losses are much lower in skip mode. VID updates while the IC is in skip mode are delayed until the next LX\_ switching pulse, which is load-dependent. If immediate VID update response is required, switch the IC to PWM mode when updating the VID.

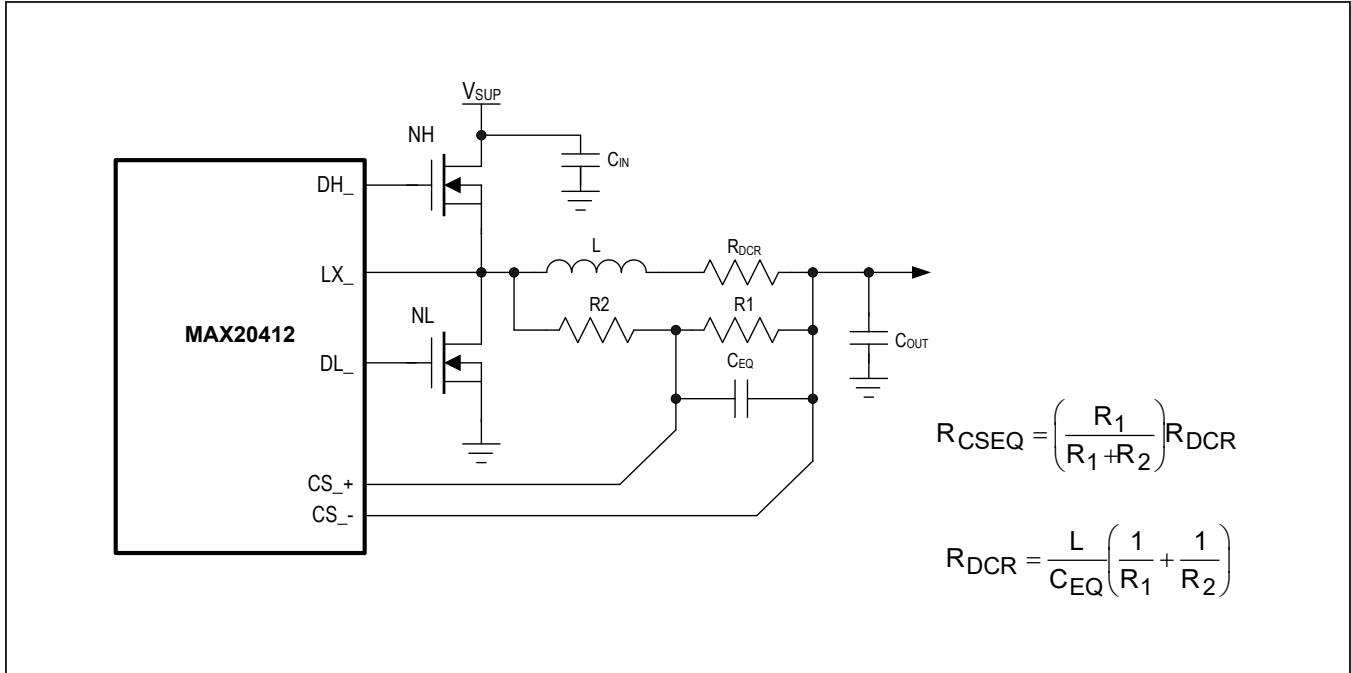

Figure 8. Current-Sense Configurations

**Dual-Phase Operation**

With the addition of a MAX15492 gate-driver IC connected to PWM1X and CS1X+, OUT1 of the MAX20412 can support two phases to increase the output current by a factor of two. The same inductor, MOSFETs, and current-limit network must be used on both phases to ensure proper current balancing. A total of 200µF to 600µF of ceramic output capacitance is required per phase, depending on load-transient requirements.

**Overtemperature Protection**

Thermal-overload protection limits the total power dissipation in the IC. When the junction temperature exceeds +165°C (typ), an internal thermal sensor shuts down the internal bias regulator and the step-down controller, allowing the IC to cool. The thermal sensor turns on the IC again after the junction temperature cools by 15°C.

**Lossless Inductor DCR Sensing**

High-power applications that do not require highly accurate current-limit protection can reduce the overall power dissipation by connecting a series RC circuit across the inductor with an equivalent time constant

**Equations 1:**

$$R_{CSEQ} = \left( \frac{R1}{R1 + R2} \right) R_{DCR}$$

and:

$$R_{DCR} = \frac{L}{C_{EQ}} \left( \frac{1}{R1} + \frac{1}{R2} \right)$$

where  $R_{CSEQ}$  is the required current-sense resistor and  $R_{DCR}$  is the inductor’s series DC resistance. Use the inductance and  $R_{DCR}$  values provided by the inductor manufacturer.

Carefully observe the PCB layout guidelines to ensure that noise and DC errors do not corrupt the differential current-sense signals seen by  $CS_+$  and  $CS_-$ . Place the sense network close to the device with short, direct traces, making a Kelvin-sense connection to the current-sense network.

**High-Side Gate-Drive Supply (BST1)**

The high-side MOSFET is turned on by closing an internal switch between BST1 and DH1 and transferring the bootstrap capacitor’s (at BST1) charge to the gate of the high-side MOSFET. This charge refreshes when the high-side MOSFET turns off and the LX1 voltage drops

down to ground potential, taking the negative terminal of the capacitor to the same potential. At this time, the bootstrap diode recharges the positive terminal of the bootstrap capacitor. The selected n-channel high-side MOSFET determines the appropriate boost-capacitance values ( $C_{BST\_}$  in the [Typical Operating Circuit](#)) according to the following equation.

**Equation 2:**

$$C_{BST\_} = \frac{Q_G}{\Delta V_{BST1}}$$

where  $Q_G$  is the total gate charge of the high-side MOSFET and  $\Delta V_{BST1}$  is the voltage variation allowed on the high-side MOSFET driver after turn-on. Choose  $\Delta V_{BST1}$  such that the available gate-drive voltage is not significantly degraded (e.g.,  $\Delta V_{BST1} = 100\text{mV}$  to  $300\text{mV}$ ) when determining  $C_{BST\_}$ .

The boost capacitor should be a low-ESR ceramic capacitor. A minimum value of  $100\text{nF}$  works in most cases.  $C_{BST2}$  is calculated using the same method described for  $C_{BST1}$ .

## Applications Information

### Input Capacitor

The input filter capacitor reduces peak currents drawn from the power source and reduces noise and voltage ripple on the input caused by the circuit's switching.

The input capacitor RMS current requirement ( $I_{RMS}$ ) is defined by the following equation.

**Equation 3:**

$$I_{RMS} = I_{LOAD(MAX)} \frac{\sqrt{V_{OUT}(V_{PV\_} - V_{OUT})}}{V_{PV\_}}$$

$I_{RMS}$  has a maximum value when the input voltage equals twice the output voltage ( $V_{PV\_} = 2V_{OUT}$ ), so  $I_{RMS(MAX)} = I_{LOAD(MAX)}/2$ .

Choose an input capacitor that exhibits less than  $+10^\circ\text{C}$  self-heating temperature rise at the RMS input current for optimal long-term reliability.

The input-voltage ripple is comprised of  $\Delta V_Q$  (caused by the capacitor discharge) and  $\Delta V_{ESR}$  (caused by the ESR of the capacitor). Use low-ESR ceramic capacitors with high ripple-current capability at the input. Assume the contribution from the ESR and capacitor discharge equal to 50%. Calculate the input capacitance and ESR required for a specified input-voltage ripple using the following equations

**Equations 4:**

$$ESR_{IN} = \frac{\Delta V_{ESR}}{I_{OUT} + \frac{\Delta I_L}{2}}$$

where:

$$\Delta I_L = \frac{(V_{PV\_} - V_{OUT}) \times V_{OUT}}{V_{PV\_} \times f_{SW} \times L}$$

and:

$$C_{IN} = \frac{I_{OUT} \times D(1-D)}{\Delta V_Q \times f_{SW}}$$

and:

$$D = \frac{V_{OUT}}{V_{PV\_}}$$

$I_{OUT}$  is the maximum output current, D is the duty cycle.

### Inductor Selection

Three key inductor parameters must be specified for operation with the MAX20412: inductance value (L), inductor saturation current ( $I_{SAT}$ ), and DC resistance ( $R_{DCR}$ ). Use the following formula to determine the minimum inductor value:

**Equation 5:**

$$L_{MIN} = 1.3 \times \left[ \frac{(V_{PVMAX} - V_{OUT}) \times \left( \frac{V_{OUT}}{V_{PVMAX}} \right)}{f_{SW} \times I_{OUTMAX} \times K_{INDMAX}} \right]$$

where  $f_{SW1}$  is the operating frequency and 1.3 is a coefficient that accounts for inductance initial precision.  $K_{INDMAX}$  is the maximum inductor current ripple. A good initial maximum inductor current ripple is 30% peak to peak ( $K_{INDMAX} = 0.3$ ).

For proper operation, the chosen inductor value must be  $\geq L_{MIN}$ . The maximum inductor value recommended is twice the chosen value from the above formula.

**MOSFET Selection**

The gate drivers drive two external logic-level n-channel MOSFETs as the circuit switch elements. To choose these MOSFETs, the key selection parameters are:

- Drain-to-Source On-Resistance ( $R_{DS(ON)}$ )
- Maximum Drain-to-Source Voltage ( $V_{DS(MAX)}$ )
- Minimum Threshold Voltage ( $V_{TH(MIN)}$ )
- Total Gate Charge ( $Q_G$ )
- Reverse Transfer Capacitance ( $C_{RSS}$ )
- Power Dissipation

Both n-channel MOSFETs must be logic-level types with guaranteed on-resistance specifications at  $V_{GS} = 4.5V$ . The conduction losses at minimum input voltage should not exceed the MOSFET package thermal limits or violate the overall thermal budget. Also ensure that the conduction losses, plus switching losses at the maximum input voltage, do not exceed package ratings or violate the overall thermal budget. In particular, check that the  $dV/dt$  caused by  $DH_+$  turning on does not pull up the  $DL_+$  gate through its drain-to-gate capacitance. This is the most frequent cause of cross-conduction problems.

Gate-charge losses are dissipated by the driver and do not heat the MOSFET; therefore, the power dissipation in the IC due to drive losses must be checked. Both MOSFETs must be selected so that their total gate charge

is low enough; thus,  $P_V/V_{OUT}$  can power both drivers without overheating the IC.

**Equation 6:**

$$P_{DRIVE} = V_{OUT} \times (Q_{GTOTH} + Q_{GTOTL}) \times f_{SW1}$$

Where  $Q_{GTOTL}$  is the low-side MOSFET total gate charge and  $Q_{GTOTH}$  is the high-side MOSFET total gate charge. Select MOSFETs with a  $Q_{G\_TOTAL}$  of less than 15nC.

The n-channel MOSFETs must deliver the average current to the load and the peak current during switching. Dual MOSFETs in a single package can be an economical solution. To reduce switching noise for smaller MOSFETs, use a series resistor in the  $DH_+$  path and additional gate capacitance. Contact the factory for guidance using gate resistors.

**Output Capacitor**

Use low-ESR ceramic capacitors on the output. Other capacitor types should be verified with a gain and phase analysis. The MAX20412's programmable compensation (Table 11) allows a wide range of capacitor values to meet different requirements. A good starting point for selecting the value is with the formula below.

**Equation 7:**

$$C(\mu F) = 10 \times \frac{I_{OUT}}{V_{OUT}}$$

## Selector Guide

| OPTION SUFFIX | V <sub>OUT1</sub> (V) |        |                |      |      | I <sup>2</sup> C | V <sub>OUT2</sub> (V) |        |                |      |      |                  |
|---------------|-----------------------|--------|----------------|------|------|------------------|-----------------------|--------|----------------|------|------|------------------|
|               | V <sub>MAX</sub>      | CONFIG | VID            | SLEW | COMP |                  | V <sub>MAX</sub>      | CONFIG | VID            | SLEW | COMP | I <sup>2</sup> C |
| A/V+          | 0x71<br>0.95V         | 0x08   | 0x5D<br>0.825V | 0x00 | 0xE0 | 0x74             | 0x71<br>0.95V         | 0x08   | 0x5D<br>0.825V | 0x00 | 0xE0 | 0x70             |
| C/V+          | 0x69<br>0.90V         | 0x08   | 0x51<br>0.75V  | 0x00 | 0xE9 | 0x74             | 0x71<br>0.95V         | 0x08   | 0x5D<br>0.825V | 0x00 | 0xE0 | 0x70             |
| D/V+          | 0x7E<br>1.03V         | 0x0C   | 0x79<br>1.00V  | 0x03 | 0xE6 | 0x70             | 0x7E<br>1.03V         | 0x0C   | 0x79<br>1.00V  | 0x03 | 0xE6 | 0x74             |

For variants with different options, contact factory.

## Ordering Information

| PART             | TEMP RANGE      | PIN-PACKAGE |
|------------------|-----------------|-------------|
| MAX20412ATJ_/_V+ | -40°C to +125°C | 32 TQFN-EP* |

**Note:** Insert the desired option suffix from the [Selector Guide](#) into the blank.

\_V Denotes an automotive-qualified part.

+Denotes a lead(Pb)-free/RoHS-compliant package.

\*EP = Exposed pad.

## Revision History

| REVISION NUMBER | REVISION DATE | DESCRIPTION  | PAGES CHANGED |
|-----------------|---------------|--|---------------|
| 0               | 6/18          | Initial release  | —             |
| 1               | 9/18          | Added future product D/V+ variant to <a href="#">Selector Guide</a>  | 28            |
| 2               | 10/18         | Replaced V <sub>OUT1</sub> and V <sub>OUT2</sub> content for future product D/V+ variant in <a href="#">Selector Guide</a> | 28            |
| 3               | 11/18         | Removed future-product designation from D/V+ variant in <a href="#">Selector Guide</a>                                     | 28            |
| 4               | 2/20          | Updated the land pattern number in <a href="#">Package Information</a>   | 3             |

For pricing, delivery, and ordering information, please visit Maxim Integrated's online storefront at <https://www.maximintegrated.com/en/storefront/storefront.html>.

*Maxim Integrated cannot assume responsibility for use of any circuitry other than circuitry entirely embodied in a Maxim Integrated product. No circuit patent licenses are implied. Maxim Integrated reserves the right to change the circuitry and specifications without notice at any time. The parametric values (min and max limits) shown in the Electrical Characteristics table are guaranteed. Other parametric values quoted in this data sheet are provided for guidance.*

## Looking for pricing, stock, or lifecycle information?

Click below to explore more details on WIN SOURCE:

 [View MAX20412ATJC/V+ on WIN SOURCE](#)

 [Analog Devices Inc. Information](#)

## Optimize Your Supply Chain with WIN SOURCE Solutions

-  Global Sourcing Solution
-  Obsolete Management
-  Cost Control Management
-  Shortage Management
-  Alternative Solution
-  Excess Inventory Management