



**THE DATASHEET OF
AH42328A-R12KHF**





AH42328A Series



Halogen Free

1. Features of AH42328A Series:

- Ferrite based SMD inductor with lower core loss.
- Inductance range: 70.0 nH to 300.0 nH , custom values are welcomed.
- High current output chokes ,up to 155.0 Amp with approx. 20% roll off.
- Low profile 8.22mm / 8.0mm / 7.90mm / 7.80mm typical Height.
- 10.90 x 8.00 mm Foot Print.
- Ideal for Buck Converter, VRM & High Density Board Design.
- Operating frequency of up to 5.0MHz.
- Operating temperature range of -55° C to + 130° C.
- RoHS & HF compliant.
- T & R Qty's: 450pcs, 13" Reel.



2. Electrical Characteristics of AH42328A Series:

ITG Part Number	OCL ¹ (nH) ± 10% or ± 15%	L@Isat1 ² (nH) MIN.	DCR ³ (mΩ) ± 5.0%	Isat1 ⁴ (A) @25°C	Isat2 ⁴ (A) @75°C	Isat3 ⁴ (A) @100°C	Irms ⁵ (A) @25°C	Dim. C (mm) ± 0.20
AH42328A-R07LHF	70.00	50.40	0.18	155.00	140.00	130.00	73.00	8.22
AH42328A-R10KHF	100.00	72.00	0.18	115.00	112.00	102.00	73.00	8.00
AH42328A-R12KHF	120.00	86.40	0.18	100.00	97.00	92.00	73.00	7.90
AH42328A-R15KHF	150.00	108.00	0.18	81.00	78.00	73.00	73.00	7.80
AH42328A-R17KHF	170.00	122.40	0.18	71.00	68.00	64.00	73.00	7.80
AH42328A-R18KHF	180.00	129.60	0.18	66.00	64.00	60.00	73.00	7.80
AH42328A-R22KHF	220.00	158.40	0.18	58.00	54.00	52.00	73.00	7.80
AH42328A-R27KHF	270.00	194.40	0.18	37.00	35.00	34.00	73.00	7.80
AH42328A-R30KHF	300.00	216.00	0.18	33.00	31.00	30.00	73.00	7.80

3. Mechanical Dimension of AH42328A Series:

A	B	C	D	E	F	G
± 0.20	± 0.20	± 0.20	± 0.20	Nom.	± 0.25	± 0.35
7.80	10.40	See table above	10.70	5.70	2.15	2.50

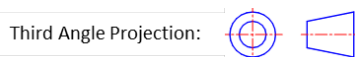
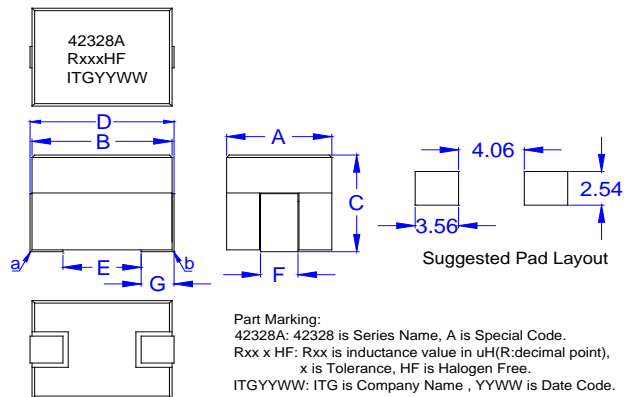

Notes:

1. Open Circuit Inductance (OCL) test condition: 500KHz,0.25Vrms,0Adc at 25°C.
2. L @ Isat and L @ Irms Test condition: 500KHz,0.25Vrms (Ta=25°C).
3. The nominal DCR is measured from point "a" to point "b", as shown above on the mechanical drawing (Ta=25°C).
4. Isat1 , Isat2 , Isat3 : DC current that will cause inductance to drop approximately by 20%.
5. Irms: DC current for an approximate temperature rise of 40°C without core loss . Derating is necessary for AC currents. PCB pad layout , trace thickness and width , air-flow and proximity of other heat generating components will affect the temperature rise.
6. It is recommended the part temperature not exceed 130° C under worst case operating conditions as verified in the end application.

● New York 1 914 347 2474 ● Taipei 886 2 2698 8669 ● Kaohsiung 886 7 350 2275
 ● Japan 81 568 85 2830 ● Shenzhen 86 755 8418 6263 ● Shanghai 86 21 5424 5141 ● Hong Kong 852 9688 9767
 ● sales@ITG-Electronics.com ● www.ITG-Electronics.com Revision G.1 : April 08 , 2021

*Due to continuous product improvement, all specifications are subject to change without prior notice. Kindly contact an ITG field application engineer or a sales representative prior to purchase.



4. Inductance Characteristics of AH42328A Series (Inductance vs Current):

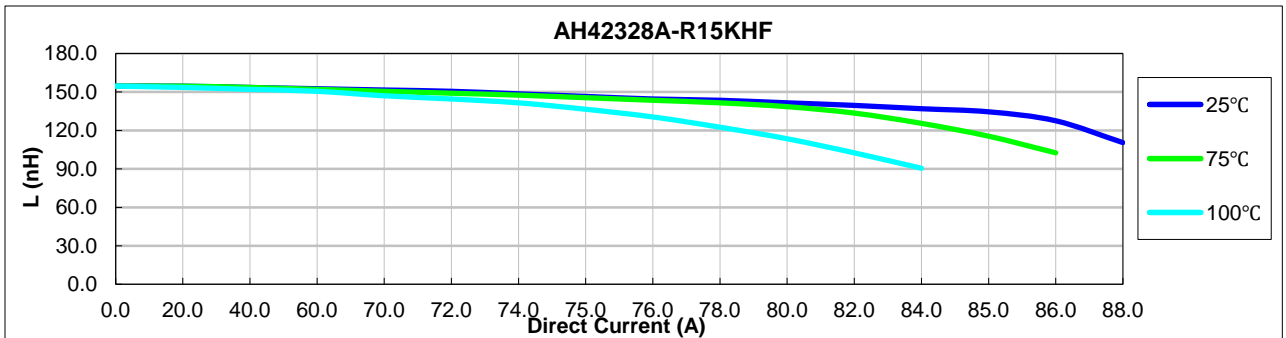
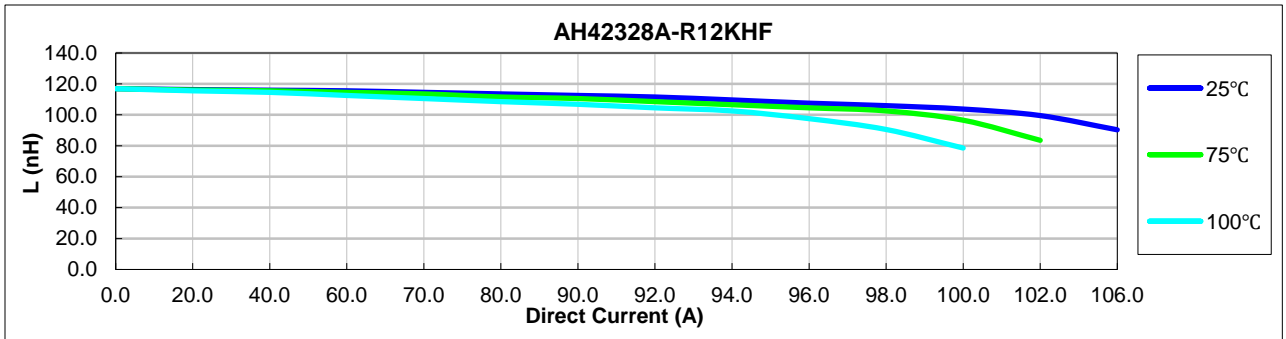
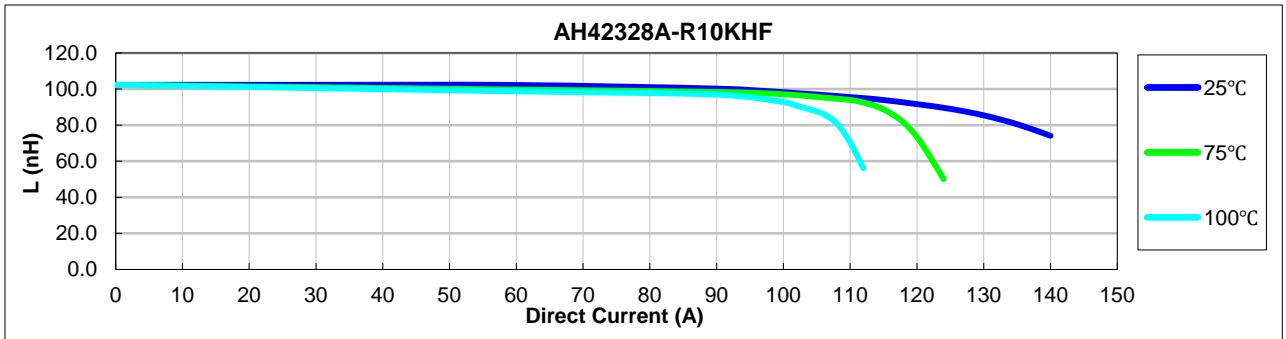
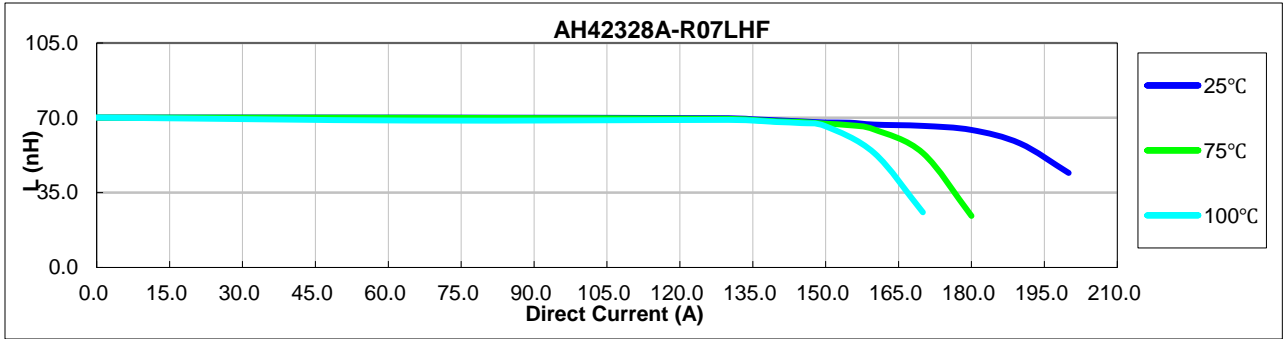



AH42328A Series



4. Inductance Characteristics of AH42328A Series (Inductance vs Current):

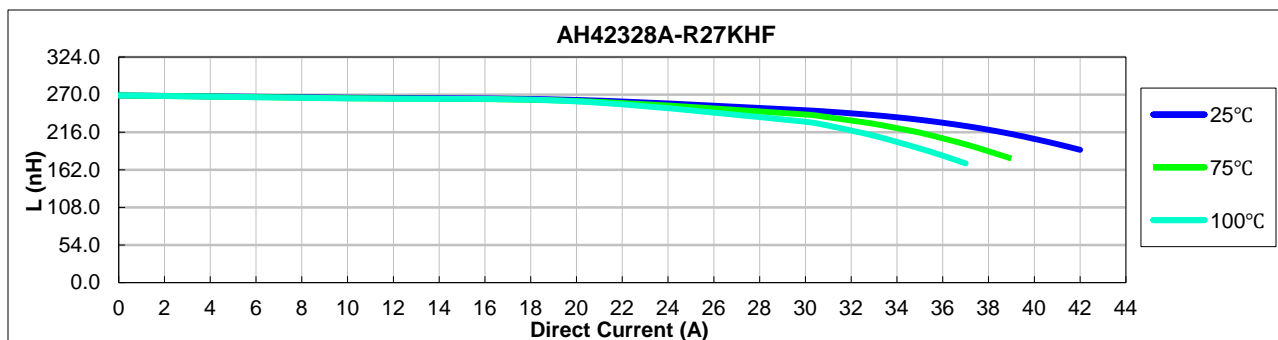
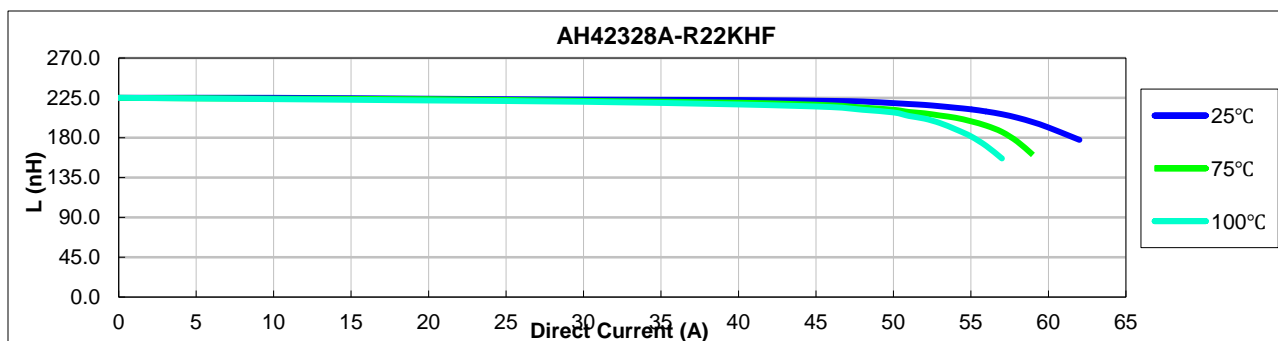
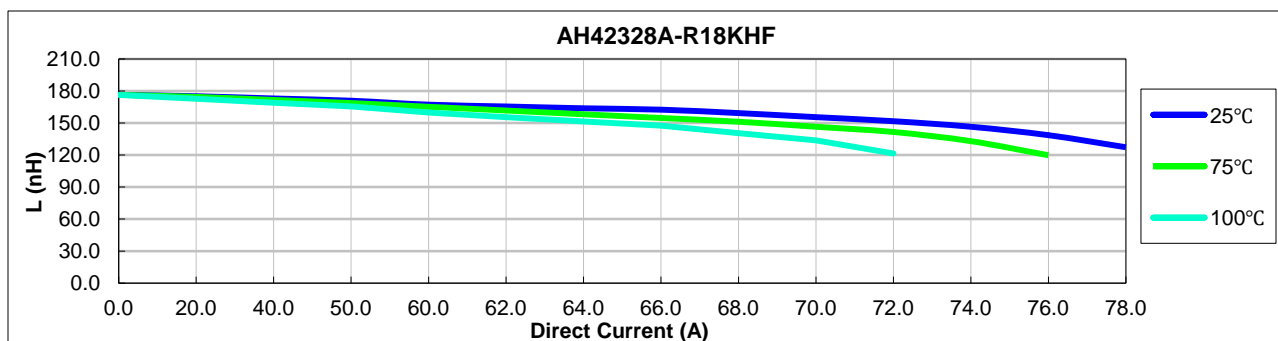
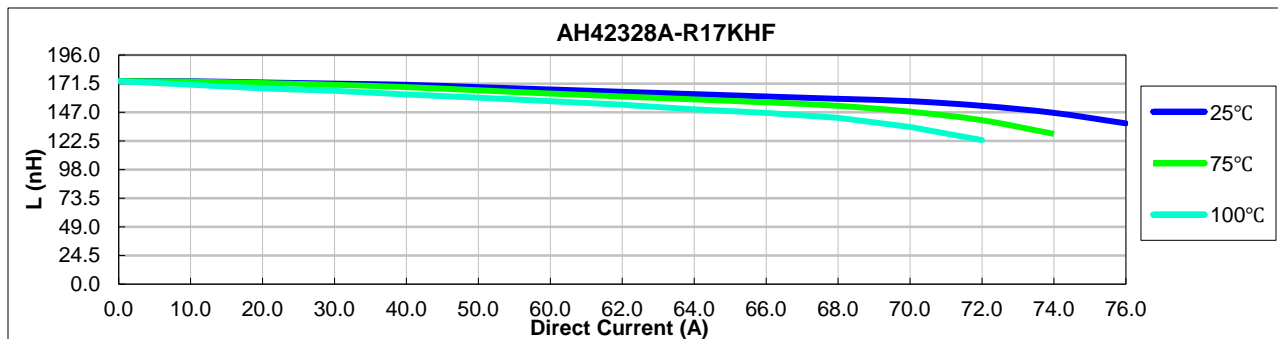

● New York 1 914 347 2474 ● Taipei 886 2 2698 8669 ● Kaohsiung 886 7 350 2275
 ● Japan 81 568 85 2830 ● Shenzhen 86 755 8418 6263 ● Shanghai 86 21 5424 5141 ● Hong Kong 852 9688 9767
 ● sales@ITG-Electronics.com ● www.ITG-Electronics.com Revision G.1 : April 08 , 2021

*Due to continuous product improvement, all specifications are subject to change without prior notice. Kindly contact an ITG field application engineer or a sales representative prior to purchase.

AH42328A Series



4. Inductance Characteristics of AH42328A Series (Inductance vs Current):

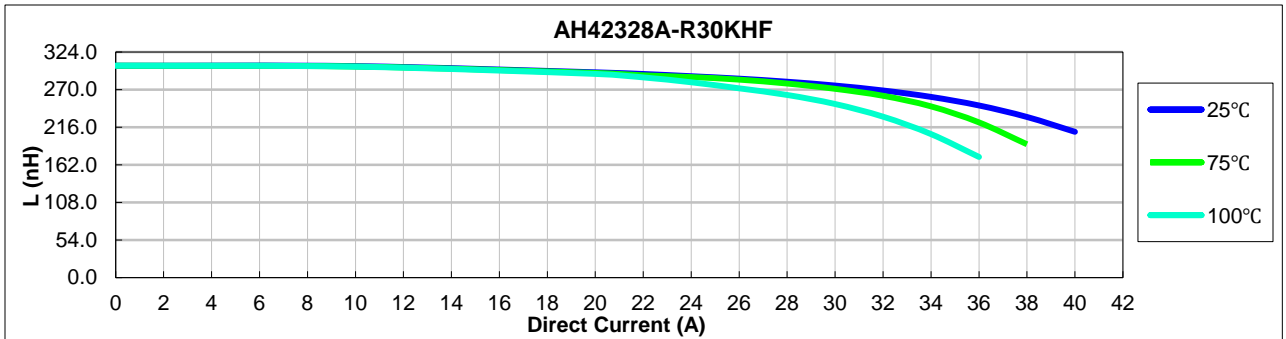



5. Core Loss:

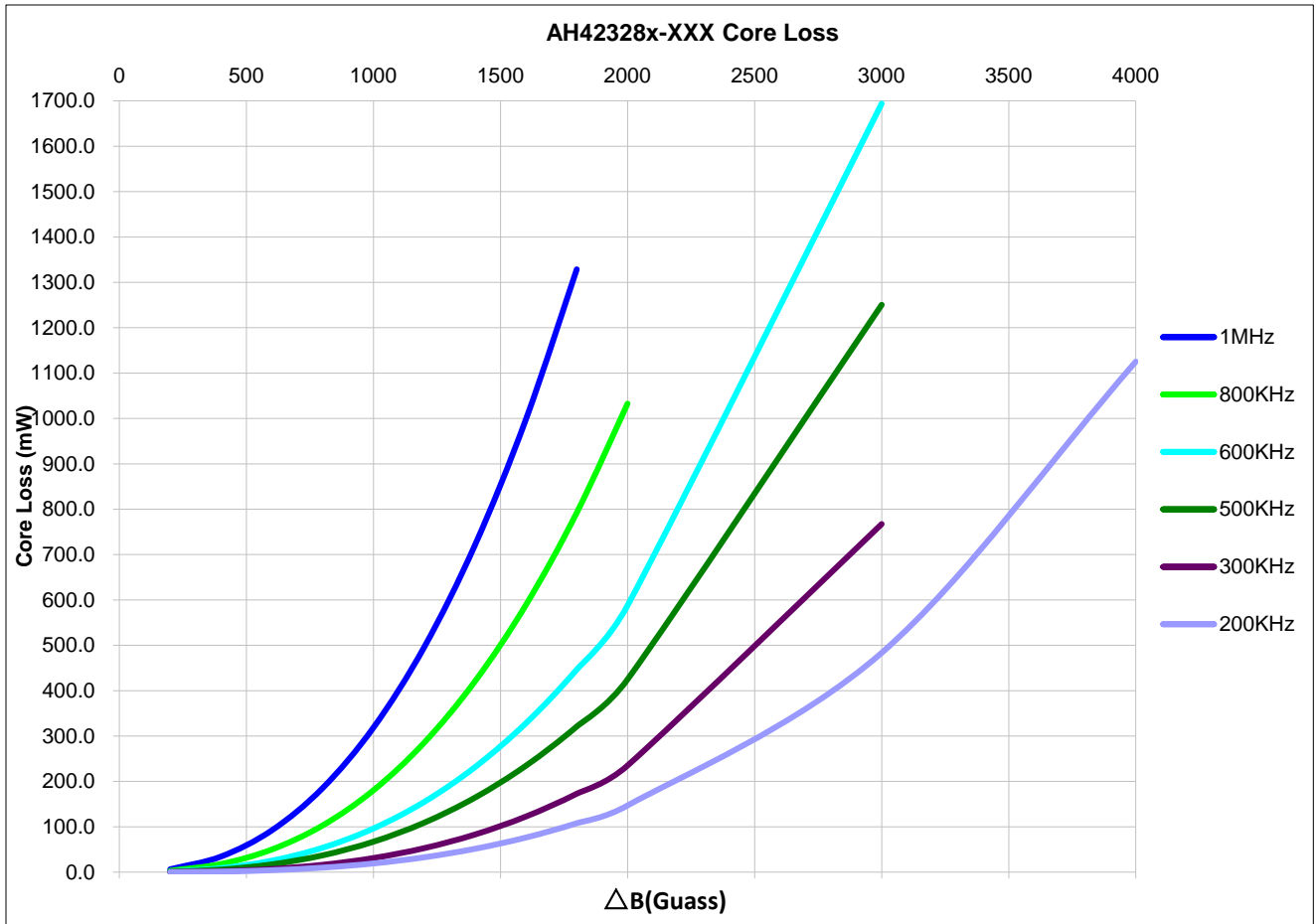

Where $\Delta B = 0.324 \cdot L(nH) \cdot \Delta I$

AH42328A Series



6. PACKAGE SPECIFICATION.(UNIT:mm):

(1).ENCAPSULATION MODE:

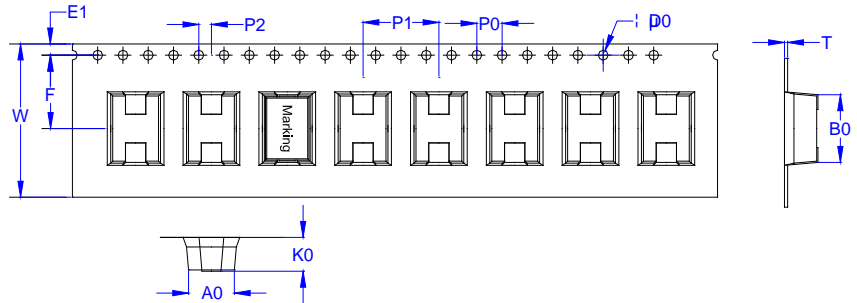

(2).DIMENSION(mm):

W	A0	B0	K0	P0	P1	P2	D0	E1	F	T
24.00+0.30/-0.10	8.20±0.10	10.80±0.10	8.20±0.10	4.00±0.10	16.00±0.10	2.00±0.10	1.50+0.10/-0	1.750±0.10	11.50±0.10	0.40±0.05

(3).REEL SIZE:

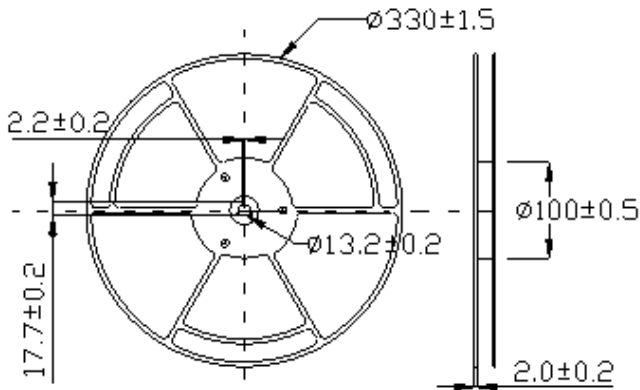

(4).PACKAGE MODE:

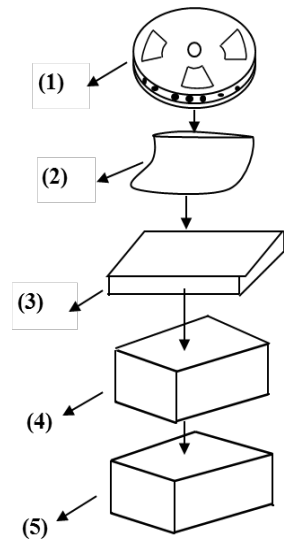

(5).PACKAGING LIST:

No.	Packing Part	Dimension (mm)	Material	Quantity
1	Reel	330	Plastic	450Pcs/Reel
2	Bag	450x360x0.075	Plastic	1Reel/Bag
3	Small Box	340X335X45	Paper	1Bag/Small Box
4	Middle Box	356X350X226	Paper	4Small Boxes/Middle Box
5	Outer Box	378X362X252	Paper	1Middle Box/Outer Box

(6).WEIGHT: N.W: 3.05g/pcs TOTAL5.49Kg(APPROX),G.W:TOTAL 11.10Kg (APPROX).

(7).Storage conditions: -40°C~85°C ,75%RH (Max.).



AH42328A Series



7.RELIABILITY TEST:

TEST ITEMS	SPECIFICATIONS	TEST METHOD AND REMARKS
Solder ability	The electrodes shall be at least 90% covered with new solder coating	According to IEC68-2-20. 1. Soldering temperature:245±5°C 2. Solder:99.3Sn/0.7Cu 3. Flux:Rosin 4. Immersion time:5±1Sec
Soldering heat resistance	1. Appearance :no damage 2. Inductance change:within±10%of initial value	1. Preheat temperature150°C. 2. Preheat time:1min 3. Solder temperature260±5°C 4. Dipping time:10±1Sec 5. Measured at room temperature after placing for 24hours
Vibration(OUT LAB)	1. Appearance:no damage 2. All Electrical and mechanical parameters within tolerance	According to MIL-STD-202G Method 201A. 1.Frequency:10 to 55Hz. 2.Amplitude:1.52mm 3.Direction and timeX Y and Z Direction for 2 hours each
Humidity resistance test	1. Appearance: no damage 2. All Electrical and mechanical parameters within tolerance	According to IEC68-2-1MethodCa: 1. Temp:40±2°C 2. Humidity:90%-95%RH 3. Test time:500±2H 4. The component should be stabilized at normal condition for24 Hours before test
High temperature resistance test	1. Appearance: no damage 2. All Electrical and mechanical parameters within tolerance	According to IEC68-2-2. 1. 1. Temperature:85±3°C 2. Test time:500+24H 3. The component should be stabilized at normal condition for 24hours before test
Low Temperature resistance test	1. Appearance: no damage 2. All Electrical and mechanical parameters within tolerance	According to IEC68-2-1 Method A(Ad). 1. Temperature:-40±3°C 2. Test time:500+24H 3. The component should be stabilized at normal condition for 24hours before test
Temperature cycles test	1. Appearance: no damage 2. All Electrical and mechanical parameters within tolerance	According to IEC68-2-14 Method N(Nb). 1. High-temp:85±3duration:30min 2. room -temp:25±2°CDuration3H 3. Low-temp:-40±3Duration30min 4. room-temp: 25±2°CDuration3H 5. Number of cycle:10cycles 6. The component should be stabilized at normal condition for 24hours before test

● New York 1 914 347 2474 ● Taipei 886 2 2698 8669 ● Kaohsiung 886 7 350 2275
 ● Japan 81 568 85 2830 ● Shenzhen 86 755 8418 6263 ● Shanghai 86 21 5424 5141 ● Hong Kong 852 9688 9767
 ● sales@ITG-Electronics.com ● www.ITG-Electronics.com Revision G.1 : April 08 , 2021

*Due to continuous product improvement, all specifications are subject to change without prior notice. Kindly contact an ITG field application engineer or a sales representative prior to purchase.



Soldering Reflow Chart

Stage	Precaution	Recommended temperature profile
Reflow soldering	<p>Temperature profile can be referenced after confirming of adhesion , temperature of resistance to soldering heat , component size , soldering etc. sufficient .</p> <p>Note: please refer to the latest IPC/JEDEC J-STD-020: "Moisture/Reflow Sensitivity Classification for Nonhermetic Solid State Surface Mount Devices"</p>	<p>Temperature °C</p> <p>260 250 220 125 25</p> <p>10s (MAX)</p> <p>60s to 90s</p> <p>Natural cooling</p> <p>150s to 210s</p> <p>240s to 480s</p>







Looking for pricing, stock, or lifecycle information?

Click below to explore more details on WIN SOURCE:

 [View AH42328A-R12KHF on WIN SOURCE](#)

 [ITG Electronics, Inc. Information](#)

Optimize Your Supply Chain with WIN SOURCE Solutions

-  Global Sourcing Solution
-  Obsolete Management
-  Cost Control Management
-  Shortage Management
-  Alternative Solution
-  Excess Inventory Management