



**THE DATASHEET OF  
CLF3H0060-30U**



# CLF3H0060-30; CLF3H0060S-30

Broadband RF power GaN HEMT

AMPLEON

Rev. 1 — 20 December 2021

Product data sheet

## 1. Product profile

### 1.1 General description

The CLF3H0060-30 and CLF3H0060S-30 are 30 W general purpose, unmatched broadband GaN-SiC HEMT transistors that are usable in the frequency range from DC to 6.0 GHz. The device utilizes a thermally enhanced package which supports both CW and pulsed applications.

**Table 1. Typical performance**

RF performance at  $T_{case} = 25\text{ °C}$ ;  $V_{DS} = 50\text{ V}$ ;  $I_{Dq} = 60\text{ mA}$ ; in a class-AB broadband demo.

Test signal	f	P <sub>L</sub>	G <sub>p</sub>	η <sub>D</sub>
	(MHz)	(W)	(dB)	(%)
CW [1]	960	30	20.18	60.61
	1050	30	20.33	60.34
	1150	30	20.51	62.17
	1250	30	20.46	66.10
	1350	30	19.97	66.40
	1400	30	19.32	65.10
pulsed CW [1][2]	960	30	20.24	61.62
	1050	30	20.40	61.58
	1150	30	20.56	62.87
	1250	30	20.57	67.10
	1350	30	20.10	67.80
	1400	30	19.44	66.48

[1] Measured on a 960 MHz to 1400 MHz broadband circuit.

[2]  $t_p = 100\text{ }\mu\text{s}$ ;  $\delta = 10\text{ }\%$ .

**Table 2. Typical performance**

RF performance at  $T_{case} = 25\text{ °C}$ ;  $V_{DS} = 50\text{ V}$ ;  $I_{Dq} = 100\text{ mA}$ ; in a class-AB broadband demo.

Test signal	f	P <sub>L</sub>	G <sub>p</sub>	η <sub>D</sub>
	(MHz)	(W)	(dB)	(%)
CW [1]	500	30	15.52	62.67
	700	30	15.37	53.75
	1000	30	15.17	49.14
	1400	30	14.87	47.38
	2000	30	15.20	47.86
	2500	30	15.36	47.37

[1] Measured on a 500 MHz to 2500 MHz broadband circuit.

**Table 3. Typical performance**

RF performance at  $T_{case} = 25\text{ }^{\circ}\text{C}$ ;  $V_{DS} = 50\text{ V}$ ;  $I_{Dq} = 60\text{ mA}$ ; in a class-AB broadband demo.

Test signal	f	P <sub>L</sub>	VSWR	Test voltage	Result
	(MHz)	(W)		(V)	
CW [1]	1300	30	15 : 1 at all phase angles	50	no device degradation
pulsed CW [2][3]	2500	30	15 : 1 at all phase angles	50	no device degradation

[1] Measured on a 1300 MHz narrowband circuit.

[2] Measured on a 2500 MHz narrowband circuit.

[3]  $t_p = 100\text{ }\mu\text{s}$ ;  $\delta = 10\text{ }\%$ .

## 1.2 Features and benefits

- 30 W general purpose broadband RF power GaN HEMT
- High efficiency
- Low thermal resistance
- Excellent ruggedness
- Designed for broadband operation in the frequency range from DC to 6.0 GHz
- For RoHS compliance see the product details on the Ampleon website
- Large signal models in ADS and MWO are available on the Ampleon website

## 2. Pinning information

**Table 4. Pinning**

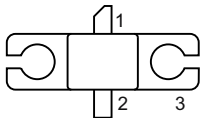
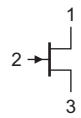
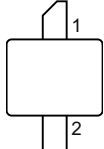
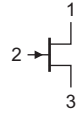
Pin	Description		Simplified outline	Graphic symbol
<b>CLF3H0060-30 (SOT1227A)</b>				
1	drain			 amp01464
2	gate			
3	source	[1]		
<b>CLF3H0060S-30 (SOT1227B)</b>				
1	drain			 amp01464
2	gate			
3	source	[1]		

[1] Connected to flange.

### 3. Ordering information

Table 5. Ordering information

Package name	Orderable part number	12NC	Packing description	Min. orderable quantity (pieces)
SOT1227A	CLF3H0060-30U	9349 603 36112	Tray; 20-fold; non-dry pack	20
SOT1227B	CLF3H0060S-30U	9349 603 37112	Tray; 20-fold; non-dry pack	20

### 4. Limiting values

Table 6. Limiting values

In accordance with the Absolute Maximum Rating System (IEC 60134).

Symbol	Parameter	Conditions	Min	Max	Unit
$V_{DS}$	drain-source voltage		-	150	V
$V_{GS}$	gate-source voltage		-8	+2	V
$I_{GF}$	forward gate current	external $R_G = 5 \Omega$	-	11	mA
$T_{stg}$	storage temperature		-65	+150	°C
$T_j$	junction temperature		[1]	225	°C

[1] Continuous use at maximum temperature will affect the reliability, for details refer to the online MTF calculator.

### 5. Thermal characteristics

Table 7. Thermal characteristics

Symbol	Parameter	Conditions	Typ	Unit
$R_{th(s-c)(IR)}$ [1]	thermal resistance from active die surface to case by Infrared measurement	$T_{case} = 85 \text{ °C}$ ; $V_{DS} = 50 \text{ V}$ ; $I_{Dq} = 70 \text{ mA}$ ; $P_{dis} = 24 \text{ W}$	3.2	K/W
$R_{th(ch-c)(FEA)}$ [2]	thermal resistance from active die channel to case by Finite Element Analysis	$T_{case} = 85 \text{ °C}$ ; $V_{DS} = 50 \text{ V}$ ; $I_{Dq} = 70 \text{ mA}$ ; $P_{dis} = 24 \text{ W}$	5.6	K/W

[1] Infrared (IR) thermal values are for reference only and cannot be used to determine performance or reliability.

[2] Finite Element Analysis (FEA) thermal values have been used for the online MTF calculator.

### 6. Characteristics

Table 8. DC characteristics

$T_{case} = 25 \text{ °C}$ ; unless otherwise specified.

Symbol	Parameter	Conditions	Min	Typ	Max	Unit
$V_{(BR)DSS}$	drain-source breakdown voltage	$V_{GS} = -8 \text{ V}$ ; $I_D = 5 \text{ mA}$	150	-	-	V
$V_{GS(th)}$	gate-source threshold voltage	$V_{DS} = 6 \text{ V}$ ; $I_D = 50 \text{ mA}$	-	-2.9	-	V
$I_{DSX}$	drain cut-off current	$V_{GS} = 2 \text{ V}$ ; $V_{DS} = 6 \text{ V}$	-	3.9	-	A
$I_{GSS}$	gate leakage current	$V_{GS} = 11 \text{ V}$ ; $V_{DS} = 6 \text{ V}$	-	-	43.75	nA
$g_{fs}$	forward transconductance	$V_{GS} = 0 \text{ V}$ ; $V_{DS} = 6 \text{ V}$	-	1.22	-	S
$R_{DS(on)}$	drain-source on-state resistance	$V_{GS} = 0 \text{ V}$ ; $V_{DS} = 100 \text{ mV}$	-	75	-	m $\Omega$

**Table 9. AC characteristics**  
*T<sub>j</sub> = 25 °C; unless otherwise specified.*

Symbol	Parameter	Conditions	Min	Typ	Max	Unit
C <sub>iss</sub>	input capacitance	V <sub>GS</sub> = -8 V; V <sub>DS</sub> = 50 V; f = 1 MHz [1]	-	6.06	-	pF
C <sub>oss</sub>	output capacitance	V <sub>GS</sub> = -8 V; V <sub>DS</sub> = 50 V; f = 1 MHz [1]	-	3.17	-	pF
C <sub>rss</sub>	reverse transfer capacitance	V <sub>GS</sub> = -8 V; V <sub>DS</sub> = 50 V; f = 1 MHz [1]	-	0.26	-	pF

[1] Include package.

**Table 10. RF characteristics**  
*Test signal: pulsed CW; t<sub>p</sub> = 100 μs; δ = 10 %; V<sub>DS</sub> = 50 V; I<sub>Dq</sub> = 70 mA; T<sub>case</sub> = 25 °C; unless otherwise specified; in a class-AB production circuit measured at 2500 MHz.*

Symbol	Parameter	Conditions	Min	Typ	Max	Unit
G <sub>p</sub>	power gain	P <sub>L</sub> = 30 W	15.5	17	-	dB
RL <sub>in</sub>	input return loss	P <sub>L</sub> = 30 W	-	-15	-	dB
η <sub>D</sub>	drain efficiency	P <sub>L</sub> = 30 W	57	61.5	-	%

## 7. Application information

### 7.1 Demo circuit information (f = 960 MHz to 1400 MHz)

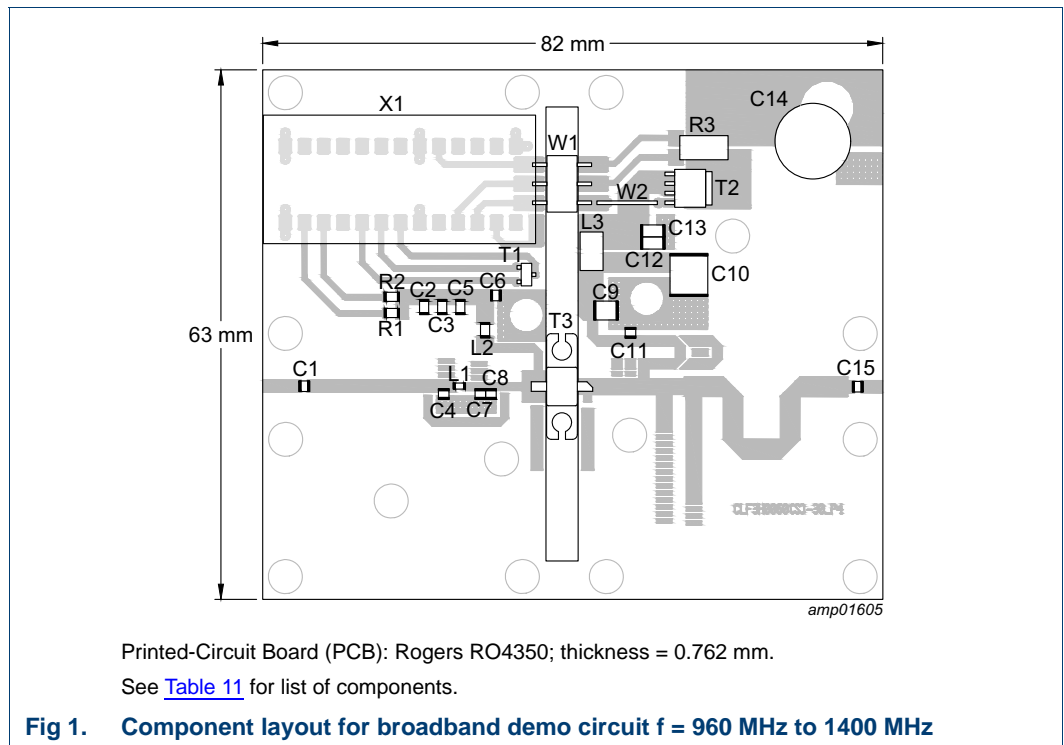

**Table 11. List of components**

For test circuit see [Figure 1](#).

Component	Description	Value	Remarks
C1	multilayer ceramic chip capacitor	82 pF	ATC 100A
C2	multilayer ceramic chip capacitor	100 nF	B37941X5104K062
C3	multilayer ceramic chip capacitor	10 pF	GRM21BR72E103KW03L
C4	multilayer ceramic chip capacitor	2.7 pF	ATC 100A
C5	multilayer ceramic chip capacitor	1 nF	GRM21AR72E102KW01D
C6	multilayer ceramic chip capacitor	82 pF	ATC 100A
C7	multilayer ceramic chip capacitor	3.9 pF	ATC 100A
C8	multilayer ceramic chip capacitor	3.6 pF	ATC 100A
C9	multilayer ceramic chip capacitor	4.7 $\mu$ F	CGA6M3X7S2A475M200AE
C10	multilayer ceramic chip capacitor	4.7 $\mu$ F	GRM55ER72A475KA01L
C11	multilayer ceramic chip capacitor	11 pF	ATC 100A
C12	multilayer ceramic chip capacitor	10 nF	VJ1206Y103KXCT
C13	multilayer ceramic chip capacitor	1 $\mu$ F	GRM31CR72A105KA01L
C14	electrolytic capacitor	220 $\mu$ F, 63 V	EEUFR1J221LB
L1	surface mount inductor	3.3 nH	B82496C3339A
L2	surface mount inductor	100 nH	MLZ2012DR10DT
L3	ferrite bead	47 $\Omega$ at 100 MHz	2743019447
R1	SMD resistor	10 k $\Omega$	0805
R2	SMD resistor	4.7 $\Omega$	0805
R3	current sense resistor	10 m $\Omega$	FC4L64R010FER
W1	connector		
W2	PTFE wire		
T1	PNP general purpose transistor		BC857A
T2	N-channel MOSFET		PSMN8R2-80YS
T3	DUT		CLF3H0060(S)-30
X1	GaN bias module		Ampleon

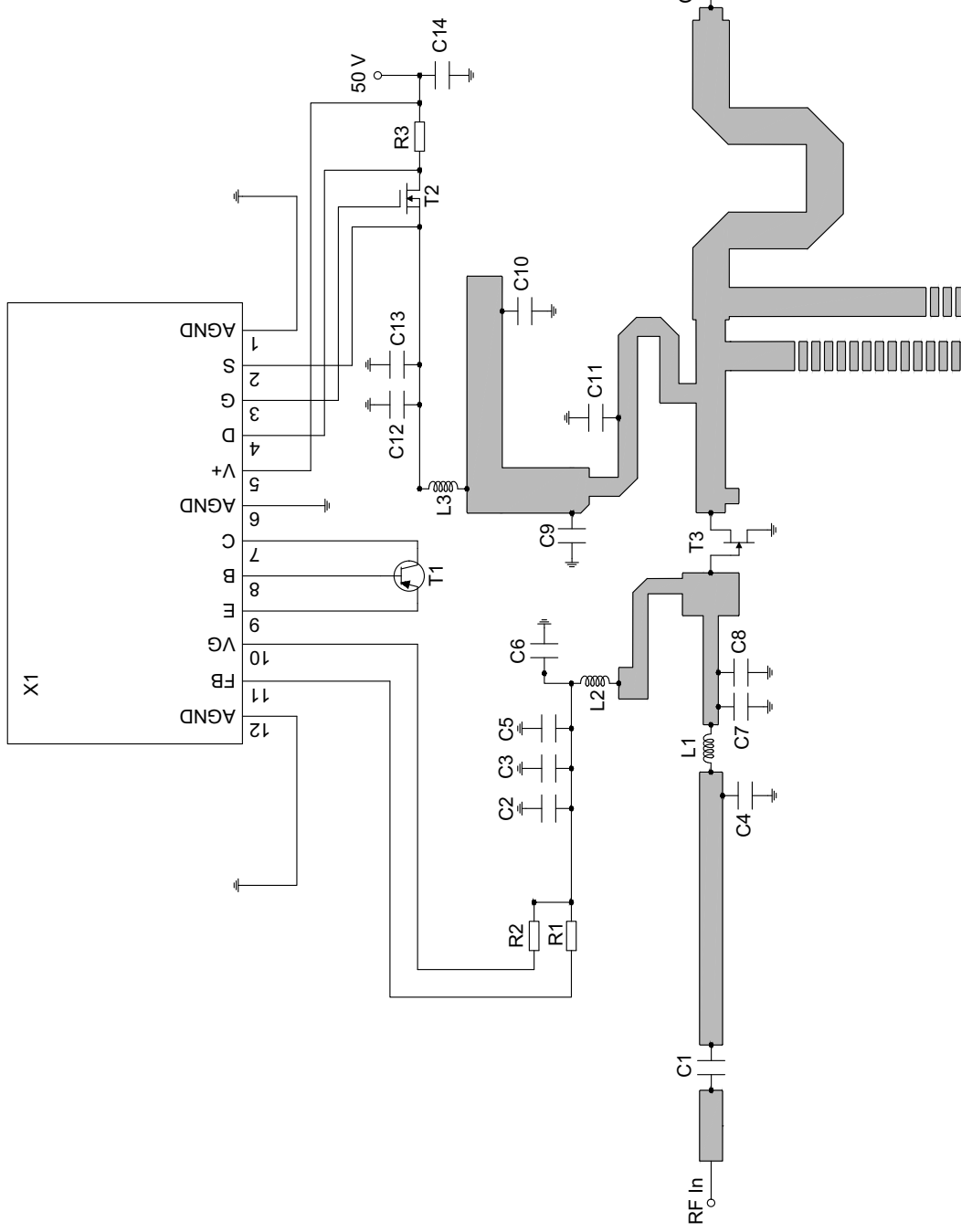
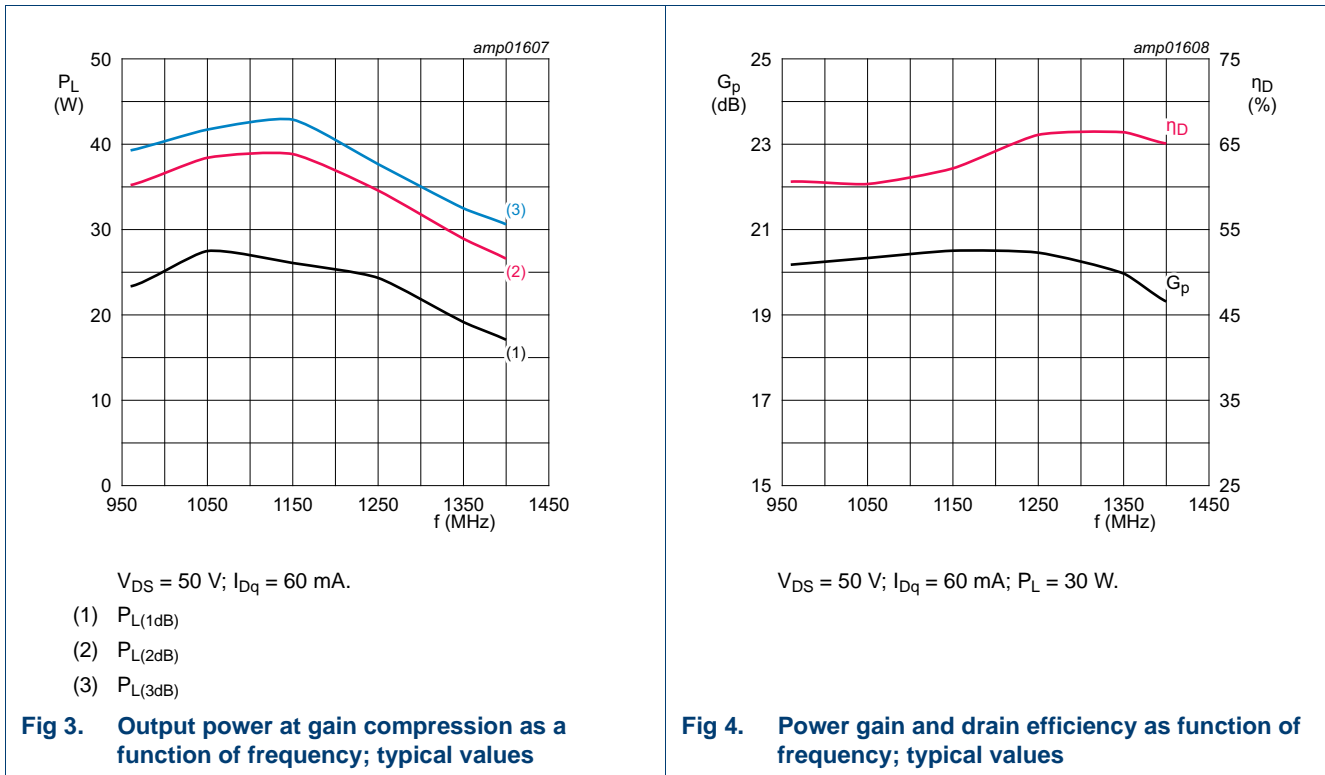
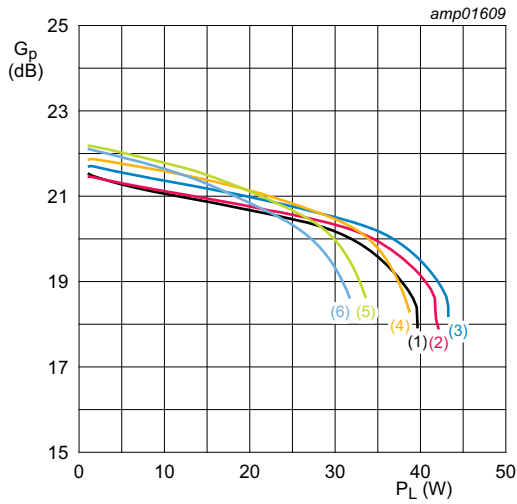

Fig 2. Schematic for broadband demo circuit  $f = 960 \text{ MHz to } 1400 \text{ MHz}$

7.2 Graphical data (f = 960 MHz to 1400 MHz)

7.2.1 CW performance





$V_{DS} = 50 \text{ V}; I_{Dq} = 60 \text{ mA}.$

- (1)  $f = 960 \text{ MHz}$
- (2)  $f = 1050 \text{ MHz}$
- (3)  $f = 1150 \text{ MHz}$
- (4)  $f = 1250 \text{ MHz}$
- (5)  $f = 1350 \text{ MHz}$
- (6)  $f = 1400 \text{ MHz}$

**Fig 5. Power gain as a function of output power; typical values**

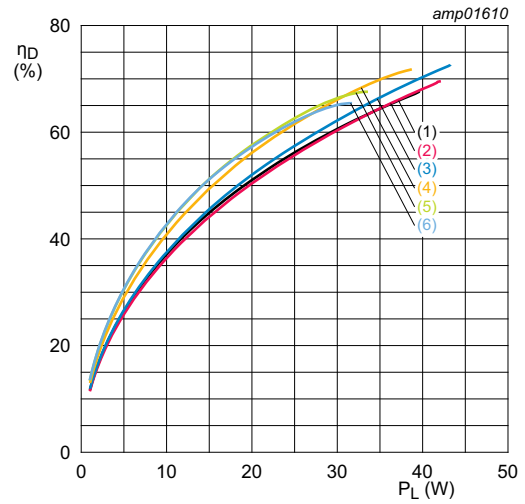

$V_{DS} = 50 \text{ V}; I_{Dq} = 60 \text{ mA}.$

- (1)  $f = 960 \text{ MHz}$
- (2)  $f = 1050 \text{ MHz}$
- (3)  $f = 1150 \text{ MHz}$
- (4)  $f = 1250 \text{ MHz}$
- (5)  $f = 1350 \text{ MHz}$
- (6)  $f = 1400 \text{ MHz}$

**Fig 6. Drain efficiency as a function of output power; typical values**

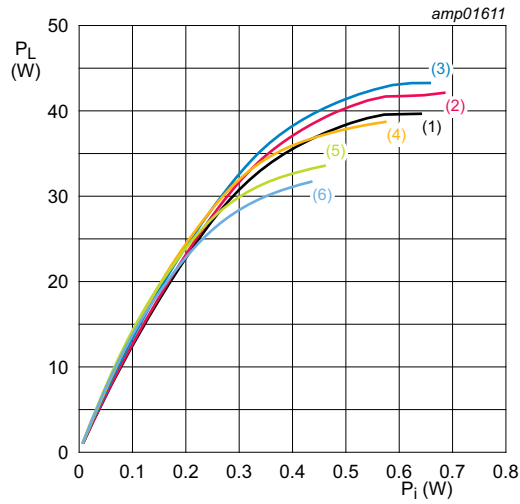

$V_{DS} = 50 \text{ V}; I_{Dq} = 60 \text{ mA}.$

- (1)  $f = 960 \text{ MHz}$
- (2)  $f = 1050 \text{ MHz}$
- (3)  $f = 1150 \text{ MHz}$
- (4)  $f = 1250 \text{ MHz}$
- (5)  $f = 1350 \text{ MHz}$
- (6)  $f = 1400 \text{ MHz}$

**Fig 7. Output power as a function of input power; typical values**

7.2.2 2-Tone CW performance

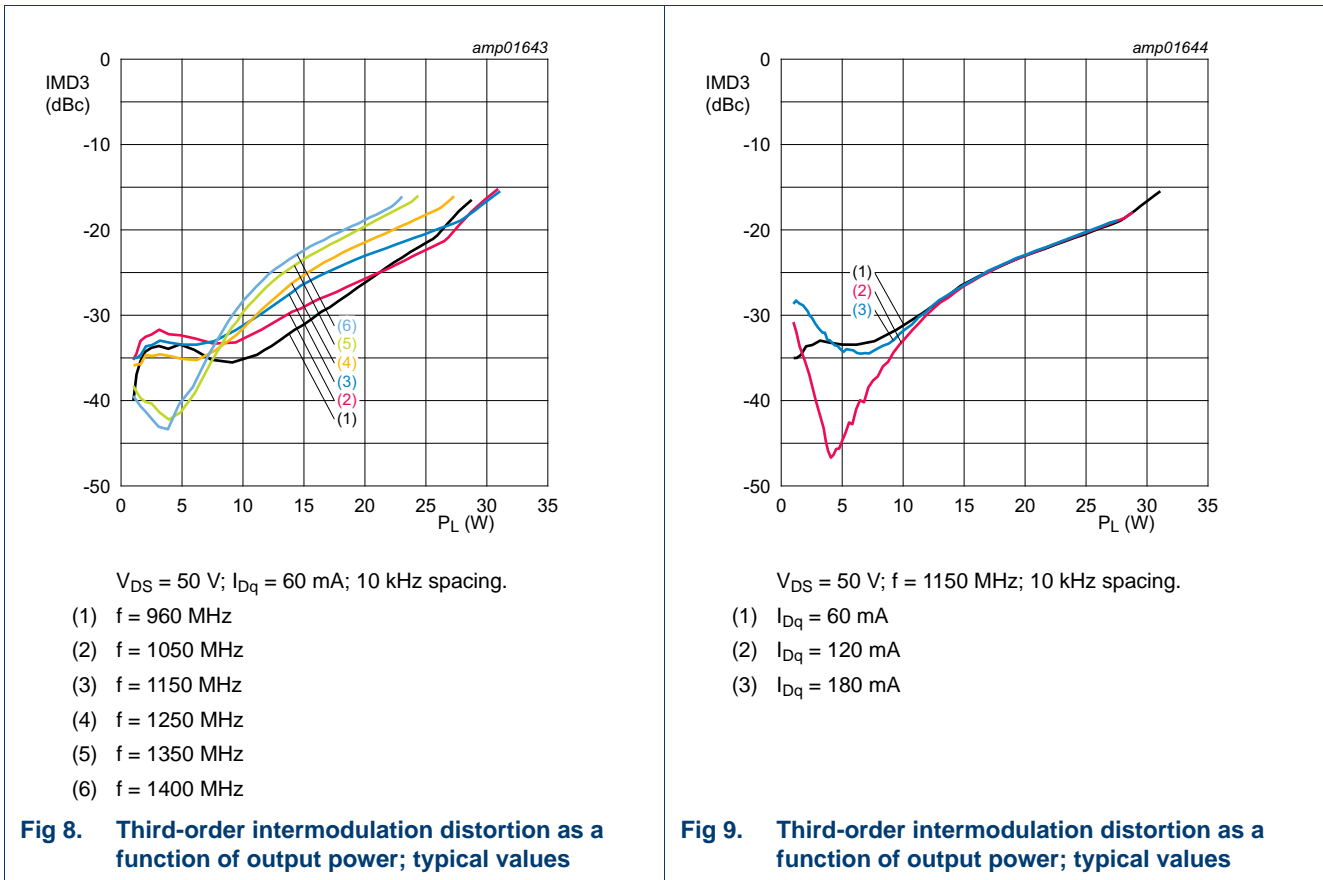

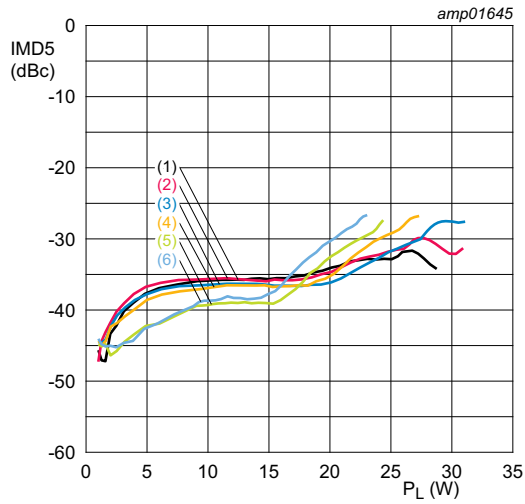

$V_{DS} = 50 \text{ V}$ ;  $I_{Dq} = 60 \text{ mA}$ ; 10 kHz spacing.

- (1)  $f = 960 \text{ MHz}$
- (2)  $f = 1050 \text{ MHz}$
- (3)  $f = 1150 \text{ MHz}$
- (4)  $f = 1250 \text{ MHz}$
- (5)  $f = 1350 \text{ MHz}$
- (6)  $f = 1400 \text{ MHz}$

**Fig 10. Fifth-order intermodulation distortion as a function of output power; typical values**

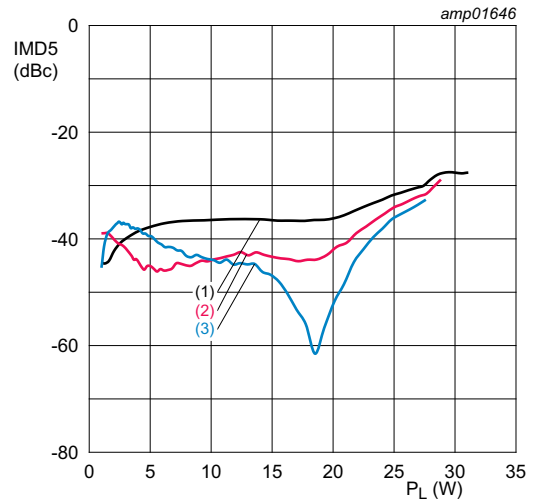

$V_{DS} = 50 \text{ V}$ ;  $f = 1150 \text{ MHz}$ ; 10 kHz spacing.

- (1)  $I_{Dq} = 60 \text{ mA}$
- (2)  $I_{Dq} = 120 \text{ mA}$
- (3)  $I_{Dq} = 180 \text{ mA}$

**Fig 11. Fifth-order intermodulation distortion as a function of output power; typical values**

7.2.3 Pulsed CW performance

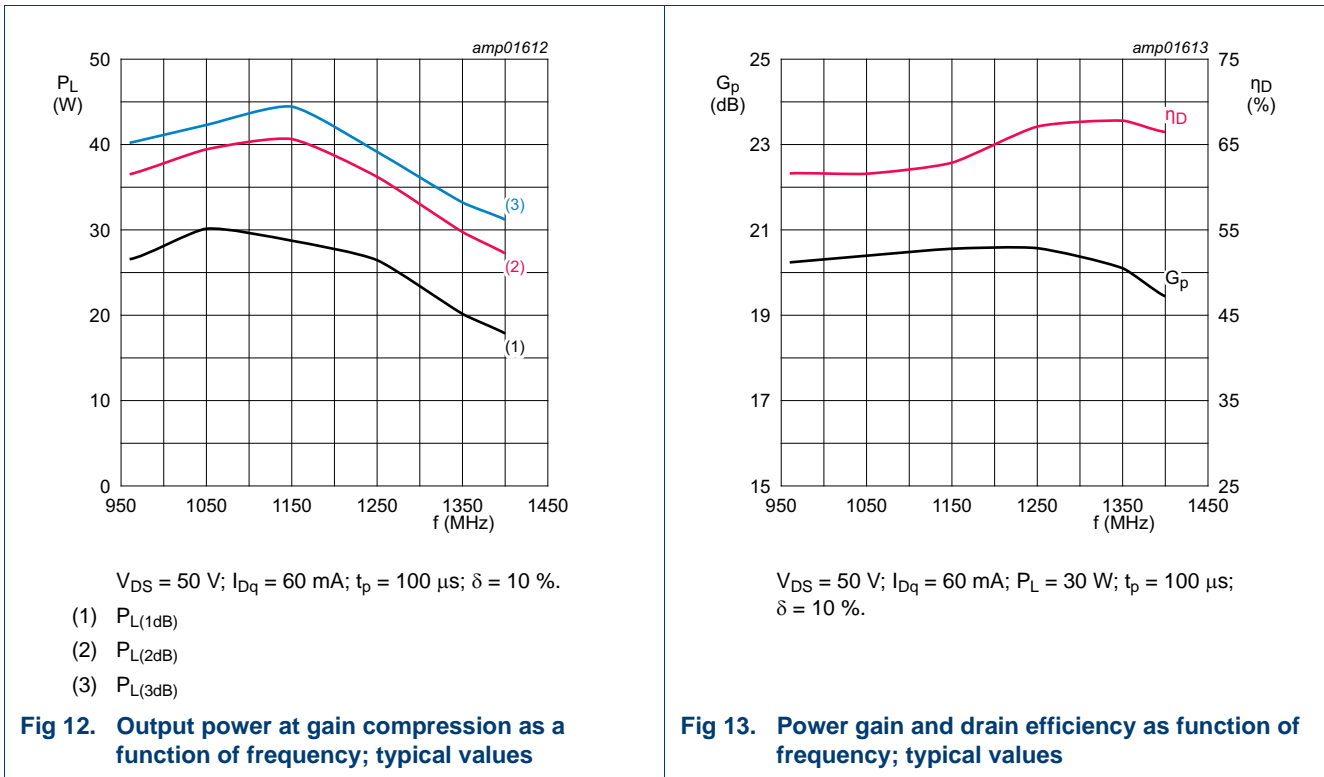

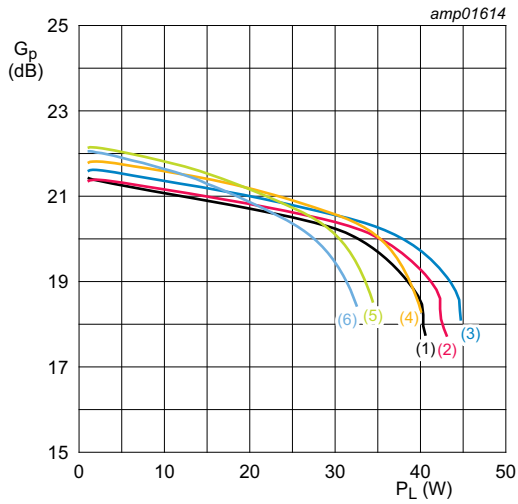

$V_{DS} = 50 \text{ V}$ ;  $I_{Dq} = 60 \text{ mA}$ ;  $t_p = 100 \text{ }\mu\text{s}$ ;  $\delta = 10 \text{ \%}$ .

- (1)  $f = 960 \text{ MHz}$
- (2)  $f = 1050 \text{ MHz}$
- (3)  $f = 1150 \text{ MHz}$
- (4)  $f = 1250 \text{ MHz}$
- (5)  $f = 1350 \text{ MHz}$
- (6)  $f = 1400 \text{ MHz}$

**Fig 14. Power gain as a function of output power; typical values**

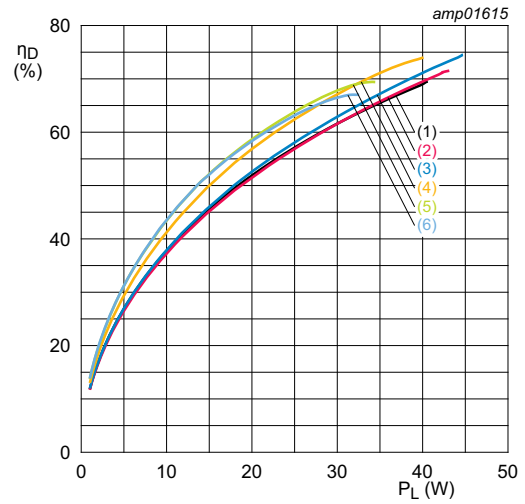

$V_{DS} = 50 \text{ V}$ ;  $I_{Dq} = 60 \text{ mA}$ ;  $t_p = 100 \text{ }\mu\text{s}$ ;  $\delta = 10 \text{ \%}$ .

- (1)  $f = 960 \text{ MHz}$
- (2)  $f = 1050 \text{ MHz}$
- (3)  $f = 1150 \text{ MHz}$
- (4)  $f = 1250 \text{ MHz}$
- (5)  $f = 1350 \text{ MHz}$
- (6)  $f = 1400 \text{ MHz}$

**Fig 15. Drain efficiency as a function of output power; typical values**

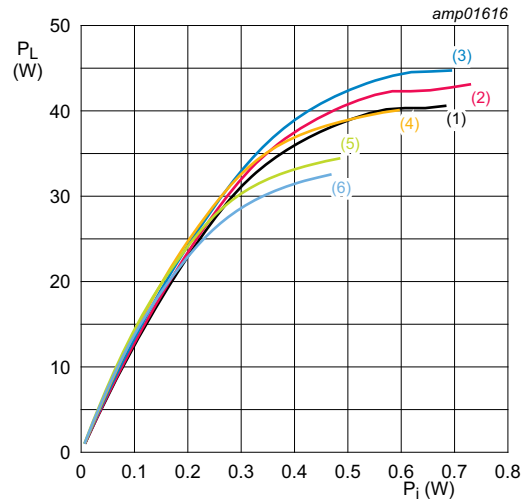

$V_{DS} = 50 \text{ V}$ ;  $I_{DQ} = 60 \text{ mA}$ ;  $t_p = 100 \text{ } \mu\text{s}$ ;  $\delta = 10 \text{ \%}$ .

- (1)  $f = 960 \text{ MHz}$
- (2)  $f = 1050 \text{ MHz}$
- (3)  $f = 1150 \text{ MHz}$
- (4)  $f = 1250 \text{ MHz}$
- (5)  $f = 1350 \text{ MHz}$
- (6)  $f = 1400 \text{ MHz}$

**Fig 16. Output power as a function of input power; typical values**

7.3 Demo circuit information (f = 500 MHz to 2500 MHz)

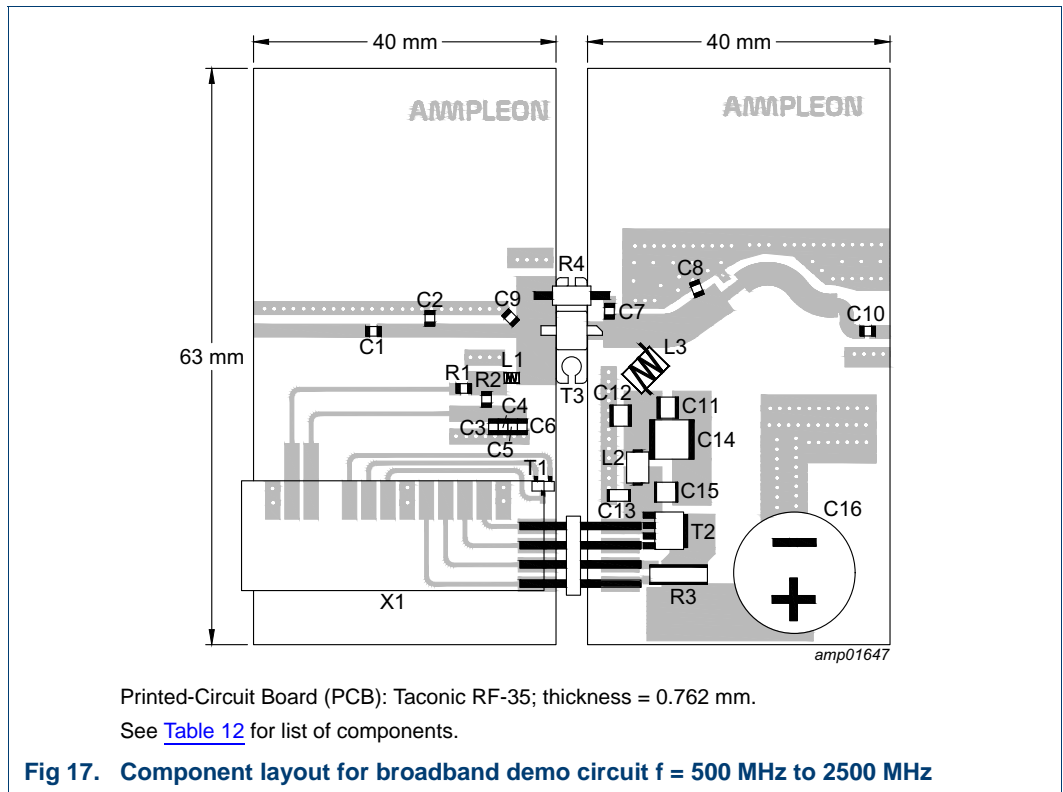

**Table 12. List of components**

For test circuit see [Figure 17](#).

Component	Description	Value	Remarks
C1	multilayer ceramic chip capacitor	8.2 pF	ATC 600F
C2	multilayer ceramic chip capacitor	0.8 pF	ATC 600F
C3	multilayer ceramic chip capacitor	100 nF, 50 V	0805 generic
C4	multilayer ceramic chip capacitor	10 nF, 50 V	0805 generic
C5	multilayer ceramic chip capacitor	22 pF, 100 V	0805 generic
C6	multilayer ceramic chip capacitor	1 nF, 100 V	0805 generic
C7	multilayer ceramic chip capacitor	10 pF	ATC 600F
C8	multilayer ceramic chip capacitor	1.1 pF	ATC 600F
C9	multilayer ceramic chip capacitor	0.5 pF	ATC 600F
C10	multilayer ceramic chip capacitor	22 pF	ATC 600F
C11	multilayer ceramic chip capacitor	100 pF	ATC 100B
C12	multilayer ceramic chip capacitor	1000 pF	ATC 100B
C13	multilayer ceramic chip capacitor	1 μF, 100 V	1206 generic
C14	multilayer ceramic chip capacitor	10 μF, 100 V	TDK C550X7S2A106M
C15	multilayer ceramic chip capacitor	1 nF, 200 V	1210 generic
C16	electrolytic capacitor	470 μF, 63 V	PCE3667CT-ND
L1	ceramic chip inductor	10 nH	Coilcraft: 1008CS-100X
L2	ferrite bead	47 Ω at 100 MHz	2743019447

**Table 12. List of components ...continued**  
 For test circuit see [Figure 17](#).

Component	Description	Value	Remarks
L3	air core inductor	12 nH	Coilcraft: GA3094
R1	SMD resistor	10 kΩ	0805
R2	SMD resistor	10 Ω	0805
R3	current sense resistor	5 mΩ	RL7520WT-R005-F
R4	resistor	200 Ω	LR12010T0200J
T1	PNP general purpose transistor		BC857A
T2	N-channel MOSFET		PSMN8R2-80YS
T3	DUT		CLF3H0060(S)-30
X1	GaN bias module		Ampleon

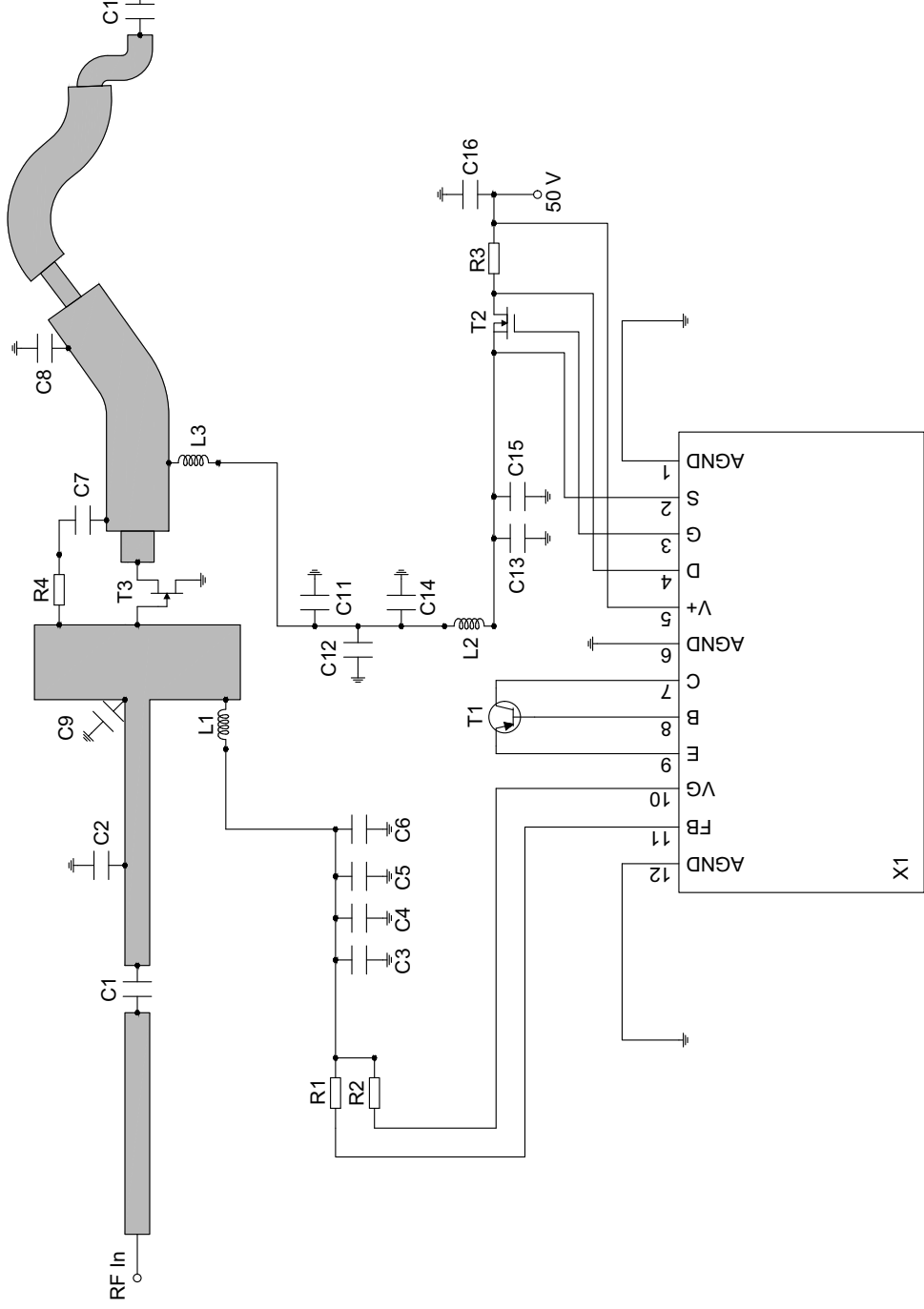
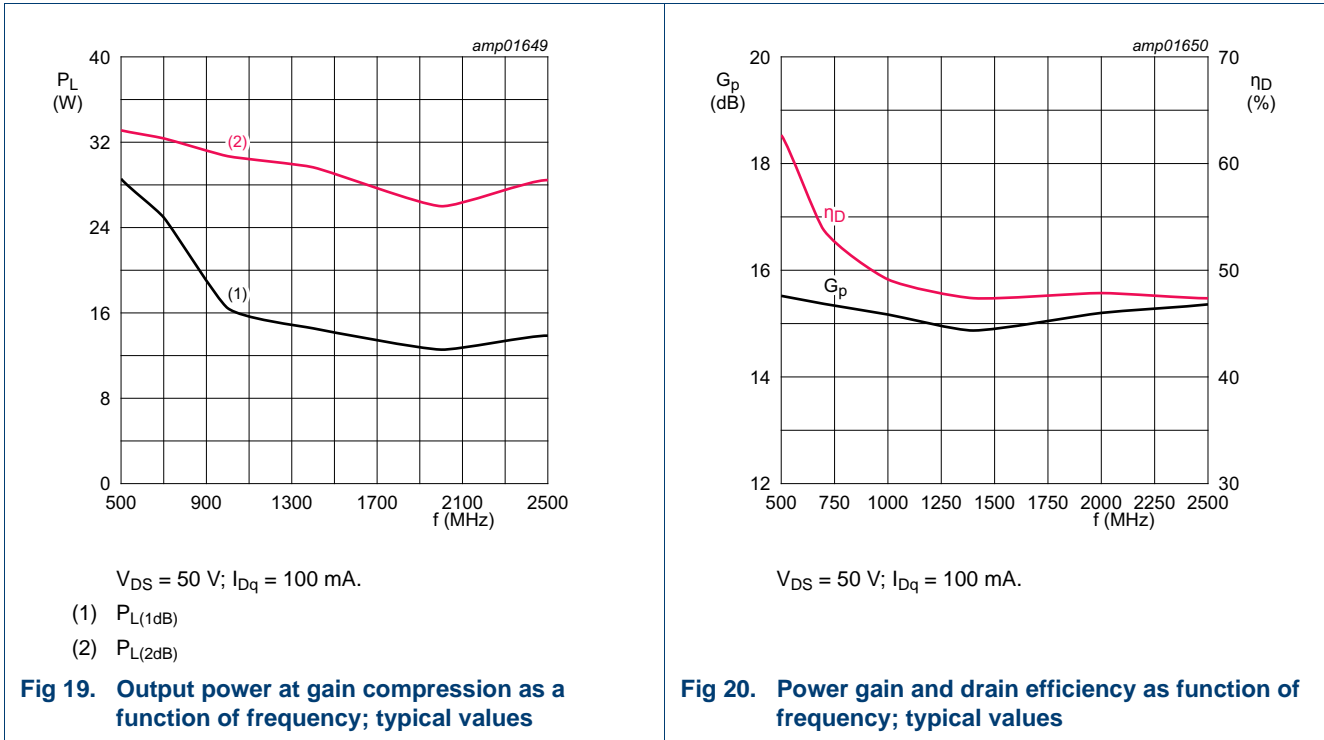
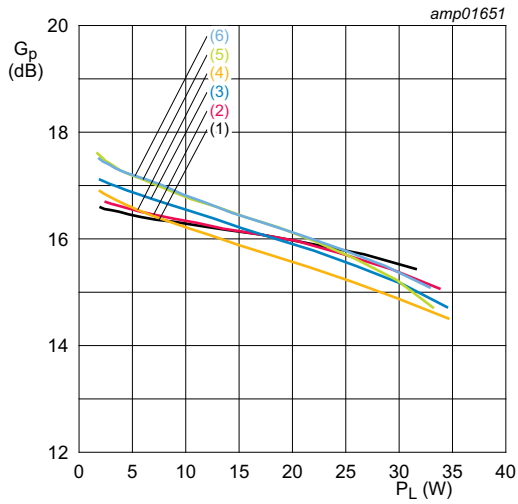

Fig 18. Schematic for broadband demo circuit  $f = 500 \text{ MHz to } 2500 \text{ MHz}$

7.4 Graphical data (f = 500 MHz to 2500 MHz)

7.4.1 CW performance





$V_{DS} = 50\text{ V}; I_{Dq} = 100\text{ mA}.$

- (1)  $f = 500\text{ MHz}$
- (2)  $f = 700\text{ MHz}$
- (3)  $f = 1000\text{ MHz}$
- (4)  $f = 1400\text{ MHz}$
- (5)  $f = 2000\text{ MHz}$
- (6)  $f = 2500\text{ MHz}$

**Fig 21. Power gain as a function of output power; typical values**

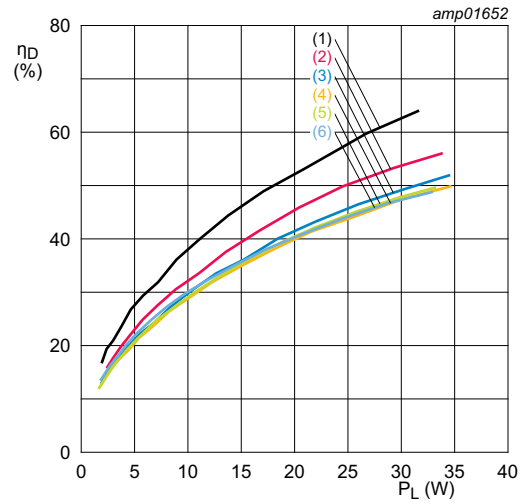

$V_{DS} = 50\text{ V}; I_{Dq} = 100\text{ mA}.$

- (1)  $f = 500\text{ MHz}$
- (2)  $f = 700\text{ MHz}$
- (3)  $f = 1000\text{ MHz}$
- (4)  $f = 1400\text{ MHz}$
- (5)  $f = 2000\text{ MHz}$
- (6)  $f = 2500\text{ MHz}$

**Fig 22. Drain efficiency as a function of output power; typical values**

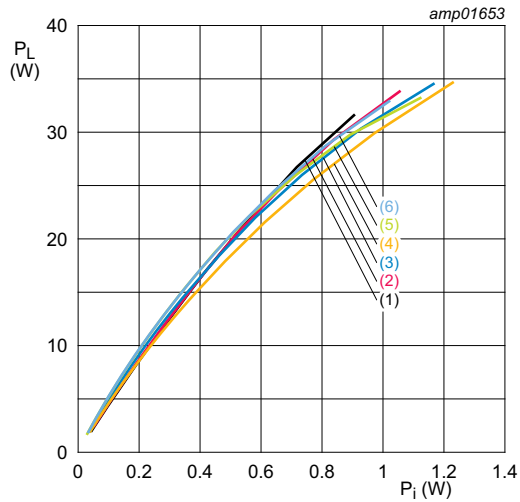

$V_{DS} = 50 \text{ V}; I_{DQ} = 100 \text{ mA}.$

- (1)  $f = 500 \text{ MHz}$
- (2)  $f = 700 \text{ MHz}$
- (3)  $f = 1000 \text{ MHz}$
- (4)  $f = 1400 \text{ MHz}$
- (5)  $f = 2000 \text{ MHz}$
- (6)  $f = 2500 \text{ MHz}$

**Fig 23. Output power as a function of input power; typical values**

7.4.2 2-Tone CW performance

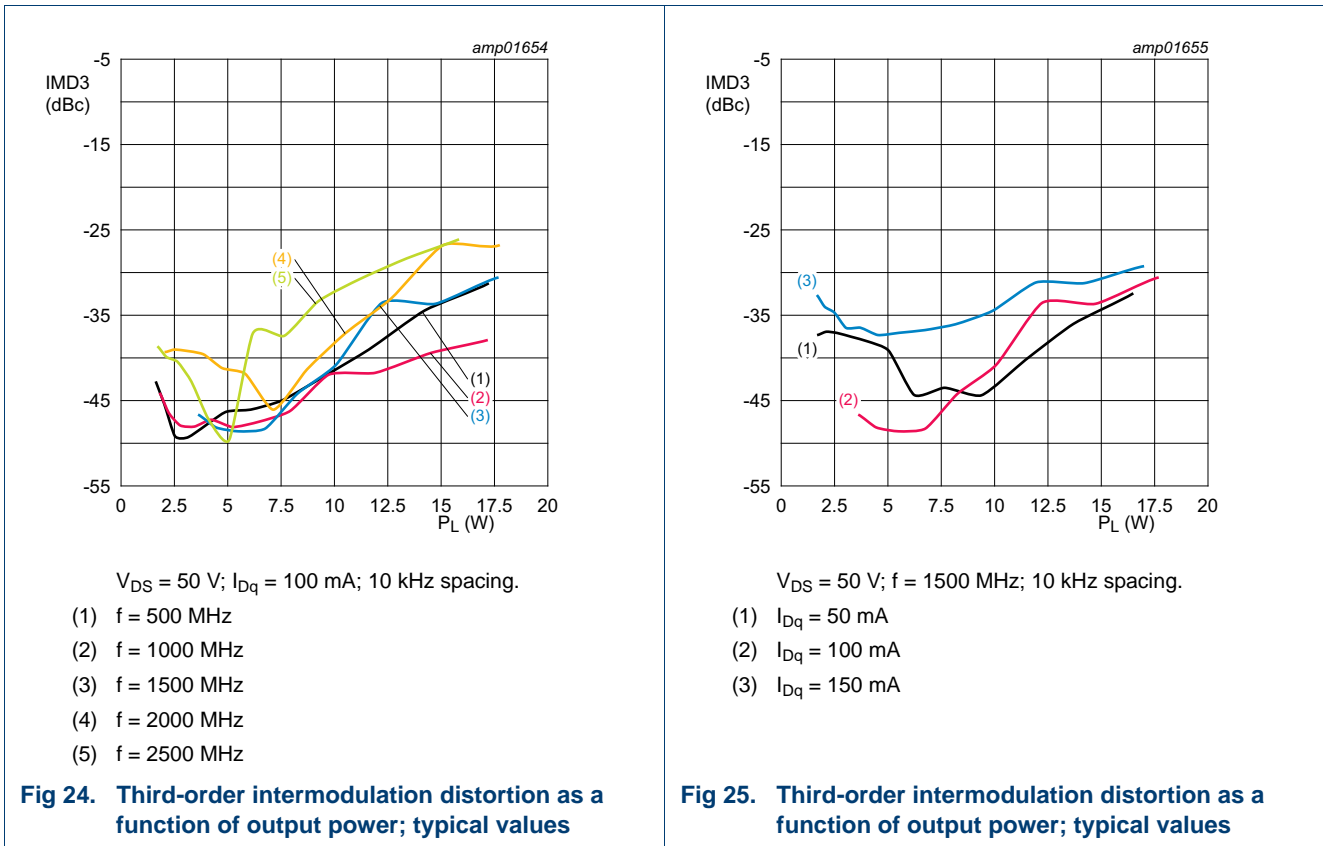

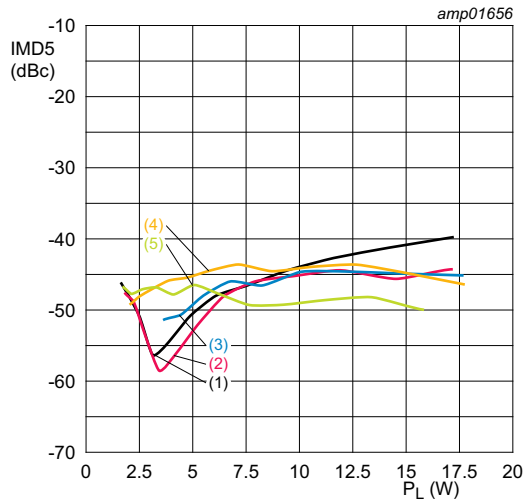

$V_{DS} = 50 \text{ V}$ ;  $I_{Dq} = 100 \text{ mA}$ ; 10 kHz spacing.

- (1)  $f = 500 \text{ MHz}$
- (2)  $f = 1000 \text{ MHz}$
- (3)  $f = 1500 \text{ MHz}$
- (4)  $f = 2000 \text{ MHz}$
- (5)  $f = 2500 \text{ MHz}$

**Fig 26. Fifth-order intermodulation distortion as a function of output power; typical values**

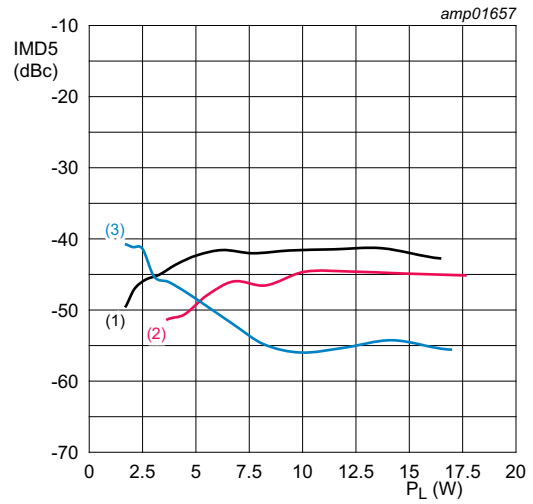

$V_{DS} = 50 \text{ V}$ ;  $f = 1500 \text{ MHz}$ ; 10 kHz spacing.

- (1)  $I_{Dq} = 50 \text{ mA}$
- (2)  $I_{Dq} = 100 \text{ mA}$
- (3)  $I_{Dq} = 150 \text{ mA}$

**Fig 27. Fifth-order intermodulation distortion as a function of output power; typical values**

## 8. Test information

### 8.1 Load-pull impedance information

The measured load-pull impedances are shown below. Impedance reference plane defined at device leads. Measurements performed with Ampleon test fixtures. Test temperature set at 25 °C with a pulsed CW signal;  $t_p = 100 \mu\text{s}$ ;  $\delta = 10 \%$ ; RF performance at  $V_{DS} = 50 \text{ V}$ ;  $I_{DQ} = 100 \text{ mA}$ .

**Table 13. Typical impedance**  
*Typical values unless otherwise specified.*

f (MHz)	Z <sub>S</sub> (Ω)	Z <sub>L</sub> (maximum P <sub>L(M)</sub> ) (Ω)	Z <sub>L</sub> (maximum η <sub>D</sub> ) (Ω)
1000	2.1 + j9.3	24.0 + j9.0	35.0 + j38.0
1400	2.0 + j4.7	21.0 + j10.0	20.0 + j22.0
1700	1.8 + j1.5	19.0 + j8.3	16.0 + j15.0
2000	2.0 – j1.2	16.0 + j6.2	16.0 + j12.0
2500	2.5 – j5.0	14.0 + j1.7	7.6 + j7.8
2700	2.3 – j6.4	12.0 + j1.3	5.1 + j6.7
3000	3.6 – j7.7	13.0 – j1.2	7.2 + j4.1
3500	4.7 – j12.6	11.8 – j3.7	8.0 + j0.9
4000	6.0 – j15.7	10.9 – j5.9	7.5 – j3.5
4500	6.8 – j17.0	9.7 – j9.5	6.1 – j6.6
5000	6.8 – j19.1	8.9 – j12.0	5.9 – j9.8

[1] Z<sub>S</sub> and Z<sub>L</sub> defined in [Figure 28](#).

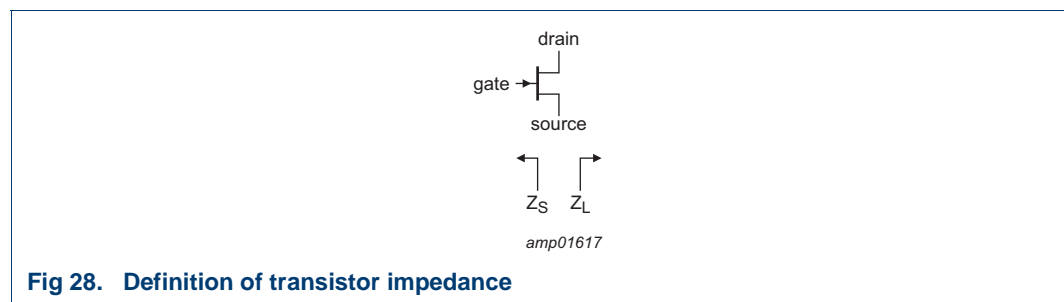

**Fig 28. Definition of transistor impedance**

Z<sub>S</sub> is the measured source pull impedance presented to the device. Z<sub>L</sub> is the measured load pull impedance presented to the device.

9. Package outline

Flanged ceramic package; 2 mounting holes; 2 leads

SOT1227A

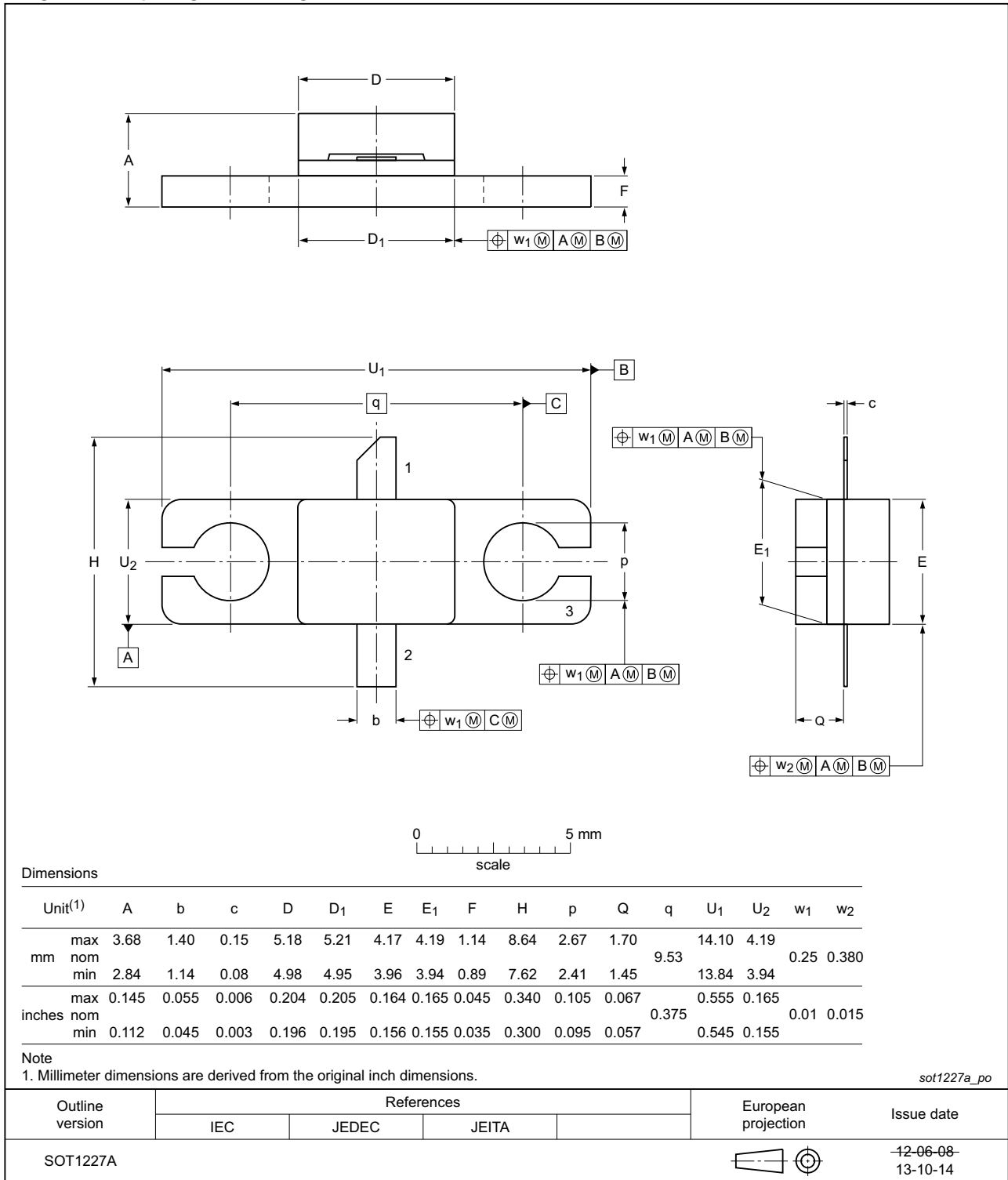

Fig 29. Package outline SOT1227A

Earless Flanged ceramic package; 2 leads

SOT1227B

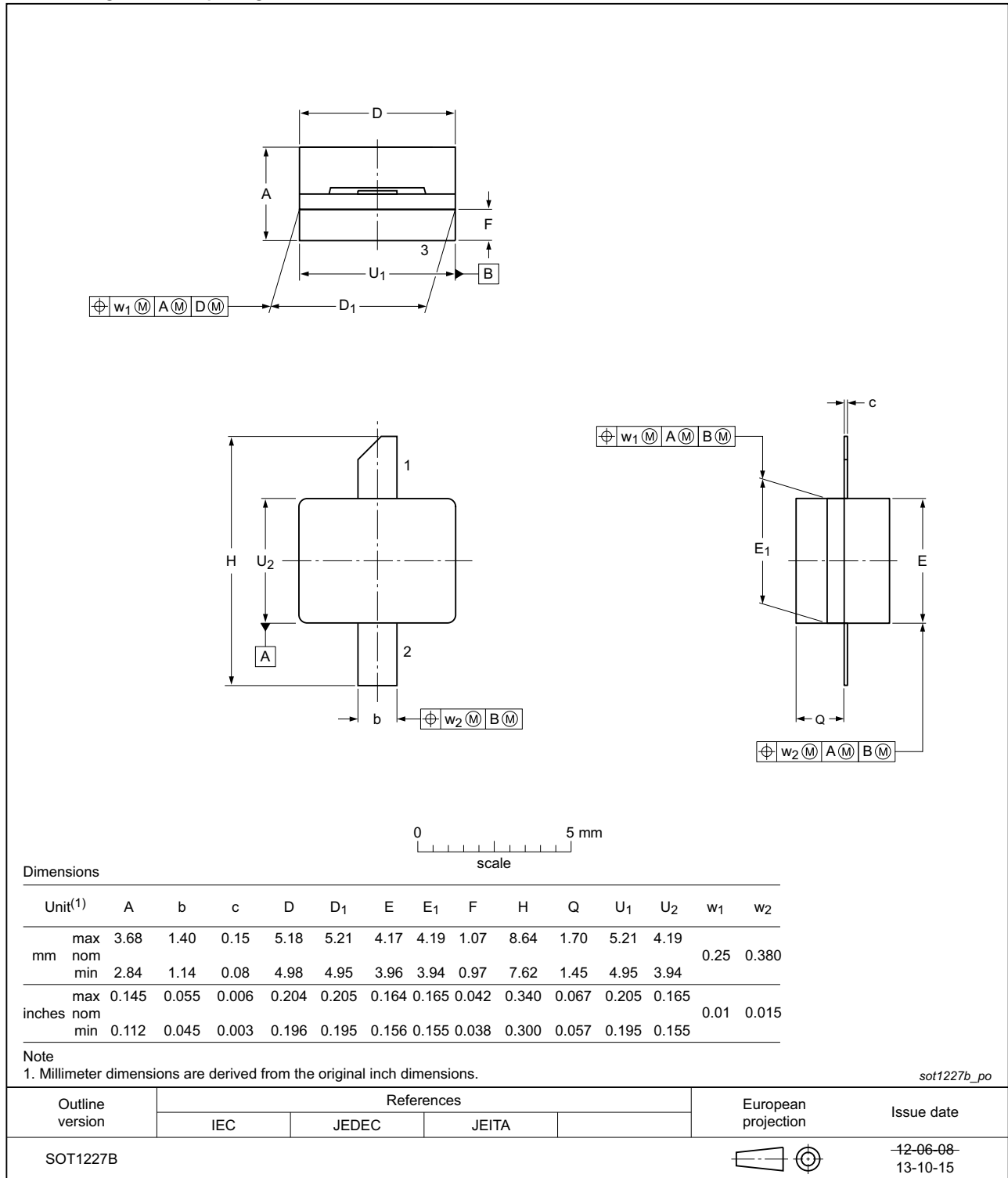

Fig 30. Package outline SOT1227B

## 10. Handling information

**CAUTION**



This device is sensitive to ElectroStatic Discharge (ESD). Observe precautions for handling electrostatic sensitive devices.

Such precautions are described in the *ANSI/ESD S20.20*, *IEC/ST 61340-5*, *JESD625-A* or equivalent standards.

**Table 14. ESD sensitivity**

ESD model	Class
Charged Device Model (CDM); According to ANSI/ESDA/JEDEC standard JS-002	C2B <a href="#">[1]</a>
Human Body Model (HBM); According to ANSI/ESDA/JEDEC standard JS-001	1A <a href="#">[2]</a>

[1] CDM classification C2B is granted to any part that passes after exposure to an ESD pulse of 750 V.

[2] HBM classification 1A is granted to any part that passes after exposure to an ESD pulse of 250 V.

## 11. Abbreviations

**Table 15. Abbreviations**

Acronym	Description
ADS	Advanced Design System
CW	Continuous Wave
DUT	Device Under Test
ESD	ElectroStatic Discharge
GaN	Gallium Nitride
HEMT	High Electron Mobility Transistor
MOSFET	Metal-Oxide Semiconductor Field-Effect Transistor
MTF	Median Time to Failure
MWO	Microwave Office
PTFE	Polytetrafluorethylene
SMD	Surface Mounted Device
RoHS	Restriction of Hazardous Substances
SiC	Silicon Carbide
VSWR	Voltage Standing Wave Ratio

## 12. Revision history

**Table 16. Revision history**

Document ID	Release date	Data sheet status	Change notice	Supersedes
CLF3H0060-30_3H0060S-30 v.1	20211220	Product data sheet	-	-

## 13. Legal information

### 13.1 Data sheet status

Document status <sup>[1][2]</sup>	Product status <sup>[3]</sup>	Definition
Objective [short] data sheet	Development	This document contains data from the objective specification for product development.
Preliminary [short] data sheet	Qualification	This document contains data from the preliminary specification.
Product [short] data sheet	Production	This document contains the product specification.

[1] Please consult the most recently issued document before initiating or completing a design.

[2] The term 'short data sheet' is explained in section "Definitions".

[3] The product status of device(s) described in this document may have changed since this document was published and may differ in case of multiple devices. The latest product status information is available on the Internet at URL <http://www.ampleon.com>.

### 13.2 Definitions

**Draft** — The document is a draft version only. The content is still under internal review and subject to formal approval, which may result in modifications or additions. Ampleon does not give any representations or warranties as to the accuracy or completeness of information included herein and shall have no liability for the consequences of use of such information.

**Short data sheet** — A short data sheet is an extract from a full data sheet with the same product type number(s) and title. A short data sheet is intended for quick reference only and should not be relied upon to contain detailed and full information. For detailed and full information see the relevant full data sheet, which is available on request via the local Ampleon sales office. In case of any inconsistency or conflict with the short data sheet, the full data sheet shall prevail.

**Product specification** — The information and data provided in a Product data sheet shall define the specification of the product as agreed between Ampleon and its customer, unless Ampleon and customer have explicitly agreed otherwise in writing. In no event however, shall an agreement be valid in which the Ampleon product is deemed to offer functions and qualities beyond those described in the Product data sheet.

### 13.3 Disclaimers

**Maturity** — The information in this document can only be regarded as final once the relevant product(s) has passed the Release Gate in Ampleon's release process. Prior to such release this document should be regarded as a draft version.

**Limited warranty and liability** — Information in this document is believed to be accurate and reliable. However, Ampleon does not give any representations or warranties, expressed or implied, as to the accuracy or completeness of such information and shall have no liability for the consequences of use of such information. Ampleon takes no responsibility for the content in this document if provided by an information source outside of Ampleon.

In no event shall Ampleon be liable for any indirect, incidental, punitive, special or consequential damages (including - without limitation - lost profits, lost savings, business interruption, costs related to the removal or replacement of any products or rework charges) whether or not such damages are based on tort (including negligence), warranty, breach of contract or any other legal theory.

Notwithstanding any damages that customer might incur for any reason whatsoever, Ampleon's aggregate and cumulative liability towards customer for the products described herein shall be limited in accordance with the *Terms and conditions of commercial sale* of Ampleon.

**No offer to sell or license** — Nothing in this document may be interpreted or construed as an offer to sell products that is open for acceptance or the grant,

**Right to make changes** — Ampleon reserves the right to make changes to information published in this document, including without limitation specifications and product descriptions, at any time and without notice. This document supersedes and replaces all information supplied prior to the publication hereof.

**Suitability for use** — Ampleon products are not designed, authorized or warranted to be suitable for use in life support, life-critical or safety-critical systems or equipment, nor in applications where failure or malfunction of an Ampleon product can reasonably be expected to result in personal injury, death or severe property or environmental damage. Ampleon and its suppliers accept no liability for inclusion and/or use of Ampleon products in such equipment or applications and therefore such inclusion and/or use is at the customer's own risk.

**Applications** — Applications that are described herein for any of these products are for illustrative purposes only. Ampleon makes no representation or warranty that such applications will be suitable for the specified use without further testing or modification.

Customers are responsible for the design and operation of their applications and products using Ampleon products, and Ampleon accepts no liability for any assistance with applications or customer product design. It is customer's sole responsibility to determine whether the Ampleon product is suitable and fit for the customer's applications and products planned, as well as for the planned application and use of customer's third party customer(s). Customers should provide appropriate design and operating safeguards to minimize the risks associated with their applications and products.

Ampleon does not accept any liability related to any default, damage, costs or problem which is based on any weakness or default in the customer's applications or products, or the application or use by customer's third party customer(s). Customer is responsible for doing all necessary testing for the customer's applications and products using Ampleon products in order to avoid a default of the applications and the products or of the application or use by customer's third party customer(s). Ampleon does not accept any liability in this respect.

**Limiting values** — Stress above one or more limiting values (as defined in the Absolute Maximum Ratings System of IEC 60134) will cause permanent damage to the device. Limiting values are stress ratings only and (proper) operation of the device at these or any other conditions above those given in the Recommended operating conditions section (if present) or the Characteristics sections of this document is not warranted. Constant or repeated exposure to limiting values will permanently and irreversibly affect the quality and reliability of the device.

**Terms and conditions of commercial sale** — Ampleon products are sold subject to the general terms and conditions of commercial sale, as published at <http://www.ampleon.com/terms>, unless otherwise agreed in a valid written individual agreement. In case an individual agreement is concluded only the terms and conditions of the respective agreement shall apply. Ampleon hereby expressly objects to applying the customer's general terms and conditions with regard to the purchase of Ampleon products by customer.

conveyance or implication of any license under any copyrights, patents or other industrial or intellectual property rights.

**Export control** — This document as well as the item(s) described herein may be subject to export control regulations. Export might require a prior authorization from competent authorities.

**Non-automotive qualified products** — Unless this data sheet expressly states that this specific Ampleon product is automotive qualified, the product is not suitable for automotive use. It is neither qualified nor tested in accordance with automotive testing or application requirements. Ampleon accepts no liability for inclusion and/or use of non-automotive qualified products in automotive equipment or applications.

In the event that customer uses the product for design-in and use in automotive applications to automotive specifications and standards, customer (a) shall use the product without Ampleon's warranty of the product for such automotive applications, use and specifications, and (b) whenever customer uses the product for automotive applications beyond Ampleon's specifications

such use shall be solely at customer's own risk, and (c) customer fully indemnifies Ampleon for any liability, damages or failed product claims resulting from customer design and use of the product for automotive applications beyond Ampleon's standard warranty and Ampleon's product specifications.

**Translations** — A non-English (translated) version of a document is for reference only. The English version shall prevail in case of any discrepancy between the translated and English versions.

## 13.4 Trademarks

Notice: All referenced brands, product names, service names and trademarks are the property of their respective owners.

## 14. Contact information

For more information, please visit: <http://www.ampleon.com>

For sales office addresses, please visit: <http://www.ampleon.com/sales>

15. Contents

1 **Product profile** . . . . . 1

1.1 General description . . . . . 1

1.2 Features and benefits . . . . . 2

2 **Pinning information** . . . . . 2

3 **Ordering information** . . . . . 3

4 **Limiting values** . . . . . 3

5 **Thermal characteristics** . . . . . 3

6 **Characteristics** . . . . . 3

7 **Application information** . . . . . 4

7.1 Demo circuit information (f = 960 MHz to 1400 MHz) . . . . . 4

7.2 Graphical data (f = 960 MHz to 1400 MHz) . . . 7

7.2.1 CW performance . . . . . 7

7.2.2 2-Tone CW performance . . . . . 10

7.2.3 Pulsed CW performance . . . . . 12

7.3 Demo circuit information (f = 500 MHz to 2500 MHz) . . . . . 15

7.4 Graphical data (f = 500 MHz to 2500 MHz) . . 18

7.4.1 CW performance . . . . . 18

7.4.2 2-Tone CW performance . . . . . 21

8 **Test information** . . . . . 23

8.1 Load-pull impedance information . . . . . 23

9 **Package outline** . . . . . 24

10 **Handling information** . . . . . 26

11 **Abbreviations** . . . . . 26

12 **Revision history** . . . . . 26

13 **Legal information** . . . . . 27

13.1 Data sheet status . . . . . 27

13.2 Definitions . . . . . 27

13.3 Disclaimers . . . . . 27

13.4 Trademarks . . . . . 28

14 **Contact information** . . . . . 28

15 **Contents** . . . . . 29

Please be aware that important notices concerning this document and the product(s) described herein, have been included in section 'Legal information'.

© Ampleon Netherlands B.V. 2021. All rights reserved.



For more information, please visit: <http://www.ampleon.com>  
 For sales office addresses, please visit: <http://www.ampleon.com/sales>

Date of release: 20 December 2021







Document identifier: CLF3H0060-30\_3H0060S-30

## Looking for pricing, stock, or lifecycle information?

Click below to explore more details on WIN SOURCE:

-  [View CLF3H0060-30U on WIN SOURCE](#)
-  [Ampleon USA Inc. Information](#)

## Optimize Your Supply Chain with WIN SOURCE Solutions

-  Global Sourcing Solution
-  Obsolete Management
-  Cost Control Management
-  Shortage Management
-  Alternative Solution
-  Excess Inventory Management