

# VTM™ Current Multiplier

## MIL-COTS MVTM36 Series



### High Efficiency, Sine Amplitude Converter™

#### Features & Benefits

- Family of MIL-COTs current multipliers covering output voltages from 1 to 50V<sub>DC</sub>
  - Operating from MIL-COTs PRM™ modules
- High efficiency reduces system power consumption
- High density provides isolated regulated system and saves space
- VI Chip® package enables surface-mount or through-hole, low impedance interconnect to system board
- Contains built-in protection features against:
  - Overvoltage
  - Overcurrent
  - Short Circuit
  - Overtemperature
- ZVS/ZCS resonant Sine Amplitude Converter topology
- Less than 50°C temperature rise at full load in typical applications

#### Typical Applications

- Land/Air/Sea Unmanned Vehicles/Drones
- Scanning Equipment
- Radar
- Mobile Weapons
- Hybrid Vehicles

#### Product Ratings

Product Ratings	
$V_{IN} = 26 - 50V$	$P_{OUT} = \text{up to } 150W$
$V_{OUT} = 1.0 - 50.0V$ (various models)	$I_{OUT} = \text{up to } 80A$

#### Product Description

The VI Chip® current multiplier is a high-efficiency Sine Amplitude Converter™ (SACT™) operating from a 26 to 50V<sub>DC</sub> primary bus to deliver an isolated output. The Sine Amplitude Converter offers a low AC impedance beyond the bandwidth of most downstream regulators, which means that capacitance normally at the load can be located at the input to the Sine Amplitude Converter. This allows for a reduction in point-of-load capacitance of typically >100x which results in a saving of board area, materials and total system cost.

The VTM current multiplier is provided in a VI Chip package compatible with standard pick-and-place and surface mount assembly processes. The co-molded VI Chip package provides enhanced thermal management due to large thermal interface area and superior thermal conductivity. With high conversion efficiency the VTM current multiplier increases overall system efficiency and lowers operating costs compared to conventional approaches.

The VTM current multiplier enables the utilization of Factorized Power Architecture™ providing efficiency and size benefits by lowering conversion and distribution losses and promoting high density point-of-load conversion.

Typical Application

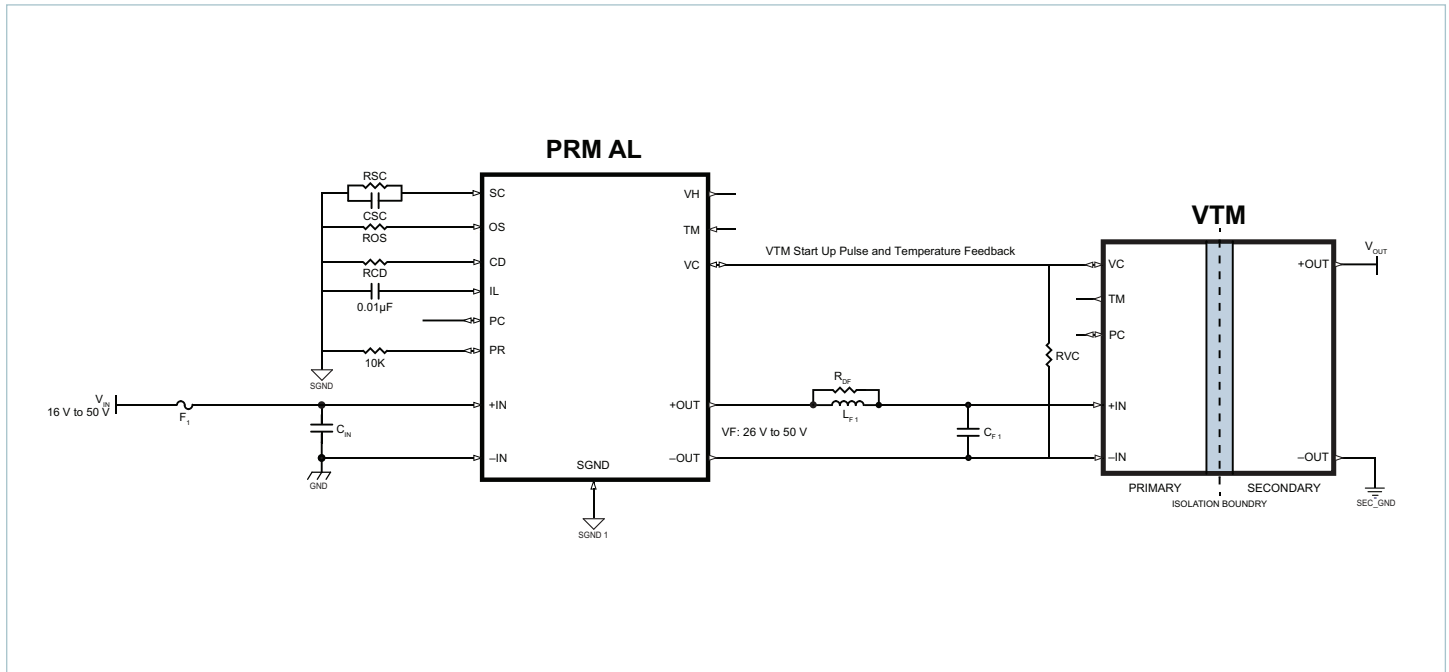

Using the MIL-COTs PRM™, the output of the VTM is regulated over the load current range with only a single interconnect between the PRM and VTM and without the need for isolation in the feedback path.

## Pin Configuration (Full)

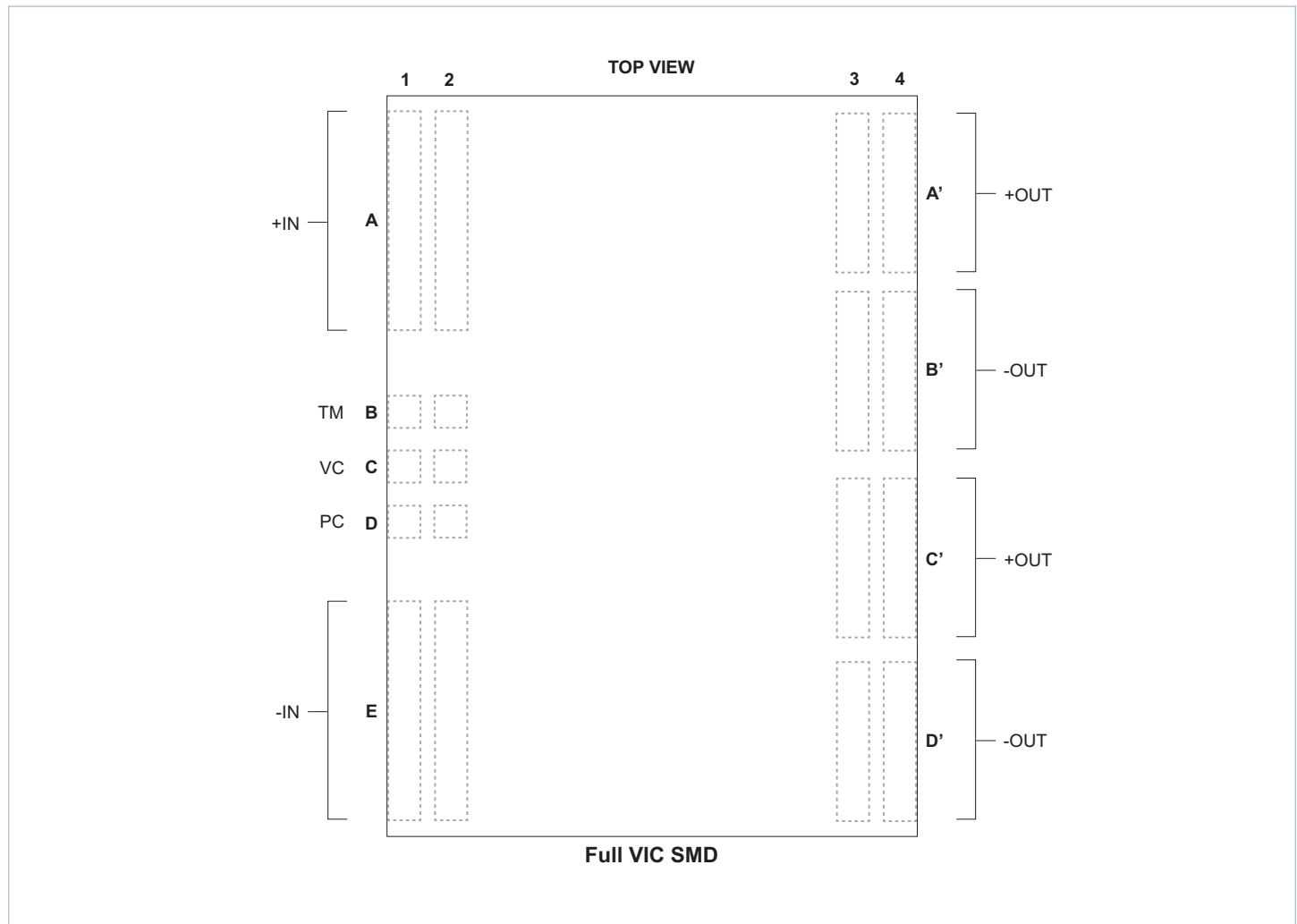

## Pin Description (Full)

Pin Number	Signal Name	Type	Function
A1, A2	+IN	INPUT POWER	Positive input power terminal
B1, B2	TM	OUTPUT	Provides voltage proportional to internal VTM controller temperature; "power good" flag
C1, C2	VC	INPUT	Connect to 12V source to power internal VTM control circuits.
D1, D2	PC	BIDIR	Enables power supply when allowed to float high; 5V during normal operation
E1, E2	-IN	INPUT POWER RETURN	Negative input power terminal
A'3, A'4, C'3, C'4	+OUT	OUTPUT POWER	Positive output power terminal
B'3, B'4, D'3, D'4	-OUT	OUTPUT POWER RETURN	Positive output power terminal

## Pin Configuration (Half)

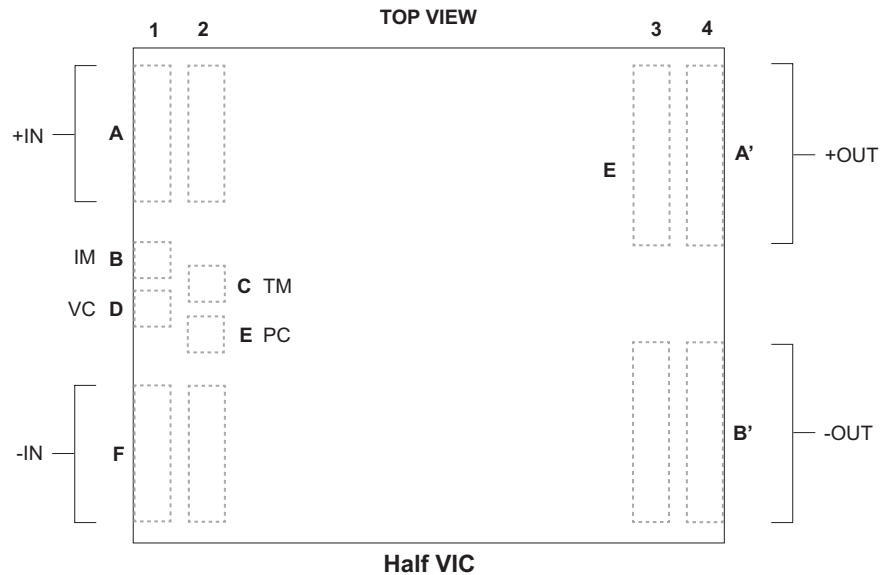

## Pin Description (Half)

Pin Number	Signal Name	Type	Function
A1, A2	+IN	INPUT POWER	Positive input power terminal
B1	IM	OUTPUT	Provides voltage proportional to load current.
C2	TM	OUTPUT	Provides voltage proportional to internal VTM controller temperature; "power good" flag
D1	VC	INPUT	Connect to 12V source to power internal VTM control circuits.
E2	PC	BIDIR	Enables power supply when allowed to float high; 5V during normal operation
F1, F2	-IN	INPUT POWER RETURN	Negative input power terminal
A'3, A'4	+OUT	OUTPUT POWER	Positive output power terminal
B'3, B'4	-OUT	OUTPUT POWER RETURN	Negative output power terminal

**Part Ordering Information**

Part Number	Package Type	Status	Input Voltage	K	Output Voltage	Output Current	Temperature Grade	Option
MVTM36BF015M080A00	F = Full VIC SMD	Active	26.0 – 50.0V	1/24	1.50V (1.08 – 2.08V)	80A	M = -55 to 125°C	00 = Standard
MVTM36BT015M080A00	T = Full VIC TH							
MVTM36BF022M055A00	F = Full VIC SMD	<b>End of Life</b>	26.0 – 50.0V	1/16	2.25V (1.63 – 3.13V)	55A		
MVTM36BT022M055A00	T = Full VIC TH							
MVTM36BF030M040B00	F = Full VIC SMD	Active	26.0 – 50.0V	1/12	3.00V (2.17 – 4.17V)	40A		
MVTM36BT030M040B00	T = Full VIC TH							
MVTM36BF045M027A00	F = Full VIC SMD	Active	26.0 – 50.0V	1/8	4.50V (3.25 – 6.25V)	27A		
MVTM36BT045M027A00	T = Full VIC TH							
MVTM36BF060M020A00	F = Full VIC SMD	Active	26.0 – 50.0V	1/6	6.00V (4.33 – 8.33V)	20A		
MVTM36BT060M020A00	T = Full VIC TH							
MVTM36BF072M017A00	F = Full VIC SMD	Active	26.0 – 50.0V	1/5	7.20V (5.20 – 10.0V)	17A		
MVTM36BT072M017A00	T = Full VIC TH							
MVTM36BF090M013A00	F = Full VIC SMD	Active	26.0 – 50.0V	1/4	9.00V (6.50 – 12.5V)	13A		
MVTM36BT090M013A00	T = Full VIC TH							
MVTM36BF120M010A00	F = Full VIC SMD	Active	26.0 – 50.0V	1/3	12.0V (8.67 – 16.7V)	10A		
MVTM36BT120M010A00	T = Full VIC TH							
MVTM36BF180M007A00	F = Full VIC SMD	Active	26.0 – 50.0V	1/2	18.0V (13.0 – 25.0V)	7A		
MVTM36BT180M007A00	T = Full VIC TH							
MVTM36BF240M005A00	F = Full VIC SMD	Active	26.0 – 50.0V	2/3	24.0V (17.3 – 33.3V)	5A		
MVTM36BT240M005A00	T = Full VIC TH							
MVTM36BF360M003A00	F = Full VIC SMD	Active	26.0 – 50.0V	1	36.0V (26.0 – 50.0V)	3A		
MVTM36BT360M003A00	T = Full VIC TH							
MVTM36BH030M025A00	H = Half VIC SMD	Active	26.0 – 50.0V	1/12	3.00V (1.63 – 3.13V)	25A		
MVTM36BH045M020A00	H = Half VIC SMD	Active	26.0 – 50.0V	1/8	4.50V (3.25 – 6.25V)	20A		
MVTM36BH090M010A00	H = Half VIC SMD	Active	26.0 – 50.0V	1/4	9.00V (6.50 – 12.5V)	10A		

All products shipped in JEDEC standard high-profile (0.400in thick) trays (JEDEC Publication 95, Design Guide 4.10).

## Absolute Maximum Ratings

The absolute maximum ratings below are stress ratings only. Operation at or beyond these maximum ratings can cause permanent damage to the device.

Parameter	Comments	Min	Max	Unit
+IN to -IN		-1.0	60	V <sub>DC</sub>
PC to -IN		-0.3	20	V <sub>DC</sub>
TM to -IN		-0.3	7	V <sub>DC</sub>
VC to -IN		-0.3	20	V <sub>DC</sub>
IM to -IN	Half Chip only	0	3.15	V <sub>DC</sub>
+IN / -IN to +OUT / -OUT (hipot)			2250	V <sub>DC</sub>

## General Electrical Characteristics

Specifications apply over all line and load conditions, unless otherwise noted; Boldface specifications apply over the temperature range of -55°C < T<sub>J</sub> < 125°C (M-Grade); All other specifications are at T<sub>J</sub> = 25°C unless otherwise noted.

Attribute	Symbol	Conditions / Notes	Min	Typ	Max	Unit
Input Voltage Range	V <sub>IN</sub>	No external VC applied	<b>26</b>		<b>50</b>	V <sub>DC</sub>
		VC applied	<b>0</b>		<b>50</b>	
V <sub>IN</sub> Slew Rate	dV <sub>IN</sub> /dt				<b>1</b>	V/μs
Output Voltage Ripple	V <sub>OUT_PP</sub>	C <sub>OUT</sub> = 0F, I <sub>OUT</sub> = Full Load, V <sub>IN</sub> = 48V, 20MHz BW		5		% V <sub>OUT</sub>
<b>Protection</b>						
Overvoltage Lockout	V <sub>IN_OVLO+</sub>	Module latched shut down	<b>52.0</b>	56.0	<b>58.5</b>	V
Overvoltage Lockout Response Time Constant	t <sub>OVLO</sub>	Effective internal RC filter		8		μs
Output Overcurrent Trip	I <sub>OCP</sub>			120		% I <sub>OUT_AVG</sub>
Short Circuit Protection Trip Current	I <sub>SCP</sub>			150		% I <sub>OUT_AVG</sub>
Output Overcurrent Response Time Constant	t <sub>OCP</sub>	Effective internal RC filter (integrative)		3.8		ms
Short Circuit Protection Response Time	t <sub>SCP</sub>	From detection to cessation of switching (instantaneous)		1		μs
Thermal Shut-Down Set Point	T <sub>J_OTP</sub>		125	130	135	°C
Reverse Inrush Current Protection		Reverse Inrush protection disabled for this product				

### Model Specific Electrical Characteristics

Specifications apply over all line and load conditions, unless otherwise noted; Boldface specifications apply over the temperature range of  $-55^{\circ}\text{C} < T_J < 125^{\circ}\text{C}$  (M-Grade); All other specifications are at  $T_J = 25^{\circ}\text{C}$  unless otherwise noted.

Attribute	Symbol	Conditions / Notes	Min	Typ	Max	Unit
<b>MVTM36BF015M080A00</b>						
No-Load Power Dissipation	$P_{NL}$	$V_{IN} = 26 - 50\text{V}$			<b>7.5</b>	W
Transfer Ratio	K	$K = V_{OUT} / V_{IN}, I_{OUT} = 0\text{A}$		1/24		V/V
Output Voltage	$V_{OUT}$	$V_{OUT} = V_{IN} \cdot K - I_{OUT} \cdot R_{OUT}$				V
Output Current (Average)	$I_{OUT\_AVG}$				<b>80</b>	A
Output Current (Peak)	$I_{OUT\_PK}$	$t_{PEAK} < 10\text{ms}, I_{OUT\_AVG} \leq 80\text{A}$			<b>120</b>	A
Efficiency (Ambient)	$\eta_{AMB}$	$V_{IN} = 36\text{V}, I_{OUT} = 80\text{A}$	90.0	91.3		%
		$V_{IN} = 26 - 50\text{V}, I_{OUT} = 80\text{A}$	87.3			
Output Resistance (Cold)	$R_{OUT\_COLD}$	$T_C = -40^{\circ}\text{C}, I_{OUT} = 80\text{A}$	0.40	0.76	1.0	m $\Omega$
Output Resistance (Ambient)	$R_{OUT\_AMB}$	$T_C = 25^{\circ}\text{C}, I_{OUT} = 80\text{A}$	0.55	0.98	1.4	m $\Omega$
Output Resistance (Hot)	$R_{OUT\_HOT}$	$T_C = 100^{\circ}\text{C}, I_{OUT} = 80\text{A}$	0.65	1.18	1.5	m $\Omega$
Switching Frequency	$f_{SW}$		<b>1.50</b>	1.60	<b>1.70</b>	MHz
Output Ripple Frequency	$f_{SW\_RP}$		<b>3.00</b>	3.20	<b>3.40</b>	MHz
MTBF		MIL-HDBK-217 Plus Parts Count; 25°C Ground Benign, Stationary, Indoors / Computer Profile		5.0		MHrs
		Telcordia Issue 2 - Method 1 Case 1; Ground Benign, Controlled		6.7		MHrs
VC Internal Resistor	$R_{VC\_INT}$			2		k $\Omega$
<b>MVTM36BF022M055A00</b>						
No-Load Power Dissipation	$P_{NL}$	$V_{IN} = 26 - 50\text{V}$			<b>8.6</b>	W
Transfer Ratio	K	$K = V_{OUT} / V_{IN}, I_{OUT} = 0\text{A}$		1/16		V/V
Output Voltage	$V_{OUT}$	$V_{OUT} = V_{IN} \cdot K - I_{OUT} \cdot R_{OUT}$				V
Output Current (Average)	$I_{OUT\_AVG}$				<b>55</b>	A
Output Current (Peak)	$I_{OUT\_PK}$	$t_{PEAK} < 10\text{ms}, I_{OUT\_AVG} \leq 55\text{A}$			<b>82</b>	A
Efficiency (Ambient)	$\eta_{AMB}$	$V_{IN} = 36\text{V}, I_{OUT} = 55\text{A}$	92.6	93.7		%
		$V_{IN} = 26 - 50\text{V}, I_{OUT} = 55\text{A}$	88.8			
Output Resistance (Cold)	$R_{OUT\_COLD}$	$T_C = -40^{\circ}\text{C}, I_{OUT} = 55\text{A}$	0.6	1.1	1.8	m $\Omega$
Output Resistance (Ambient)	$R_{OUT\_AMB}$	$T_C = 25^{\circ}\text{C}, I_{OUT} = 55\text{A}$	0.8	1.4	1.9	m $\Omega$
Output Resistance (Hot)	$R_{OUT\_HOT}$	$T_C = 100^{\circ}\text{C}, I_{OUT} = 55\text{A}$	1.0	1.7	2.2	m $\Omega$
Switching Frequency	$f_{SW}$		<b>1.36</b>	1.43	<b>1.50</b>	MHz
Output Ripple Frequency	$f_{SW\_RP}$		<b>2.72</b>	2.86	<b>3.00</b>	MHz
MTBF		MIL-HDBK-217 Plus Parts Count; 25°C Ground Benign, Stationary, Indoors / Computer Profile		1.9		MHrs
		Telcordia Issue 2 - Method 1 Case 1; Ground Benign, Controlled		6.0		MHrs
VC Internal Resistor	$R_{VC\_INT}$			1.0		k $\Omega$

**Model Specific Electrical Characteristics (Cont.)**

Specifications apply over all line and load conditions, unless otherwise noted; Boldface specifications apply over the temperature range of  $-55^{\circ}\text{C} < T_J < 125^{\circ}\text{C}$  (M-Grade); All other specifications are at  $T_J = 25^{\circ}\text{C}$  unless otherwise noted.

Attribute	Symbol	Conditions / Notes	Min	Typ	Max	Unit
<b>MVTM36BF030M040B00</b>						
No-Load Power Dissipation	$P_{NL}$	$V_{IN} = 26 - 50\text{V}$			<b>12.0</b>	W
Transfer Ratio	K	$K = V_{OUT} / V_{IN}, I_{OUT} = 0\text{A}$		1/12		V/V
Output Voltage	$V_{OUT}$	$V_{OUT} = V_{IN} \cdot K - I_{OUT} \cdot R_{OUT}$				V
Output Current (Average)	$I_{OUT\_AVG}$				<b>40</b>	A
Output Current (Peak)	$I_{OUT\_PK}$	$t_{PEAK} < 10\text{ms}, I_{OUT\_AVG} \leq 40\text{A}$			<b>60</b>	A
Efficiency (Ambient)	$\eta_{AMB}$	$V_{IN} = 36\text{V}, I_{OUT} = 40\text{A}$	92.5	94.0		%
		$V_{IN} = 26 - 50\text{V}, I_{OUT} = 40\text{A}$	90.2			
Output Resistance (Cold)	$R_{OUT\_COLD}$	$T_C = -40^{\circ}\text{C}, I_{OUT} = 40\text{A}$	1.0	1.6	2.3	m $\Omega$
Output Resistance (Ambient)	$R_{OUT\_AMB}$	$T_C = 25^{\circ}\text{C}, I_{OUT} = 40\text{A}$	1.5	2.2	3.0	m $\Omega$
Output Resistance (Hot)	$R_{OUT\_HOT}$	$T_C = 100^{\circ}\text{C}, I_{OUT} = 40\text{A}$	2.0	2.6	3.3	m $\Omega$
Switching Frequency	$f_{SW}$		<b>1.36</b>	1.43	<b>1.50</b>	MHz
Output Ripple Frequency	$f_{SW\_RP}$		<b>2.72</b>	2.86	<b>3.00</b>	MHz
MTBF		MIL-HDBK-217 Plus Parts Count; 25°C Ground Benign, Stationary, Indoors / Computer Profile		3.8		MHrs
		Telcordia Issue 2 - Method 1 Case 1; Ground Benign, Controlled		9.5		MHrs
VC Internal Resistor	$R_{VC-INT}$			1.0		k $\Omega$
<b>MVTM36BF045M027A00</b>						
No-Load Power Dissipation	$P_{NL}$	$V_{IN} = 26 - 50\text{V}$			<b>7.0</b>	W
Transfer Ratio	K	$K = V_{OUT} / V_{IN}, I_{OUT} = 0\text{A}$		1/8		V/V
Output Voltage	$V_{OUT}$	$V_{OUT} = V_{IN} \cdot K - I_{OUT} \cdot R_{OUT}$				V
Output Current (Average)	$I_{OUT\_AVG}$				<b>27</b>	A
Output Current (Peak)	$I_{OUT\_PK}$	$t_{PEAK} < 10\text{ms}, I_{OUT\_AVG} \leq 27\text{A}$			<b>40</b>	A
Efficiency (Ambient)	$\eta_{AMB}$	$V_{IN} = 36\text{V}, I_{OUT} = 27\text{A}$	93.0	94.7		%
		$V_{IN} = 26\text{V to } 55\text{V}, I_{OUT} = 27\text{A}$	89.3			
Output Resistance (Cold)	$R_{OUT\_COLD}$	$T_C = -40^{\circ}\text{C}, I_{OUT} = 27\text{A}$	2.5	4.6	5.9	m $\Omega$
Output Resistance (Ambient)	$R_{OUT\_AMB}$	$T_C = 25^{\circ}\text{C}, I_{OUT} = 27\text{A}$	3.8	6.0	7.8	m $\Omega$
Output Resistance (Hot)	$R_{OUT\_HOT}$	$T_C = 100^{\circ}\text{C}, I_{OUT} = 27\text{A}$	4.5	7.1	9.0	m $\Omega$
Switching Frequency	$f_{SW}$		<b>1.10</b>	1.21	<b>1.30</b>	MHz
Output Ripple Frequency	$f_{SW\_RP}$		<b>2.20</b>	2.42	<b>2.60</b>	MHz
MTBF		MIL-HDBK-217 Plus Parts Count; 25°C Ground Benign, Stationary, Indoors / Computer Profile		3.8		MHrs
		Telcordia Issue 2 - Method 1 Case 1; Ground Benign, Controlled		9.5		MHrs
VC Internal Resistor	$R_{VC-INT}$			1.0		k $\Omega$

**Model Specific Electrical Characteristics (Cont.)**

Specifications apply over all line and load conditions, unless otherwise noted; Boldface specifications apply over the temperature range of  $-55^{\circ}\text{C} < T_J < 125^{\circ}\text{C}$  (M-Grade); All other specifications are at  $T_J = 25^{\circ}\text{C}$  unless otherwise noted.

Attribute	Symbol	Conditions / Notes	Min	Typ	Max	Unit
<b>MVTM36BF060M020A00</b>						
No-Load Power Dissipation	$P_{NL}$	$V_{IN} = 26 - 50\text{V}$			<b>14.0</b>	W
Transfer Ratio	K	$K = V_{OUT} / V_{IN}, I_{OUT} = 0\text{A}$		1/6		V/V
Output Voltage	$V_{OUT}$	$V_{OUT} = V_{IN} \cdot K - I_{OUT} \cdot R_{OUT}$				V
Output Current (Average)	$I_{OUT\_AVG}$				<b>20</b>	A
Output Current (Peak)	$I_{OUT\_PK}$	$t_{PEAK} < 10\text{ms}, I_{OUT\_AVG} \leq 20\text{A}$			<b>30</b>	A
Efficiency (Ambient)	$\eta_{AMB}$	$V_{IN} = 36\text{V}, I_{OUT} = 20\text{A}$	94.6	95.5		%
		$V_{IN} = 26 - 50\text{V}, I_{OUT} = 20\text{A}$	92.0			
Output Resistance (Cold)	$R_{OUT\_COLD}$	$T_C = -40^{\circ}\text{C}, I_{OUT} = 20\text{A}$	3.0	7.0	9.0	m $\Omega$
Output Resistance (Ambient)	$R_{OUT\_AMB}$	$T_C = 25^{\circ}\text{C}, I_{OUT} = 20\text{A}$	5.0	8.0	10.0	m $\Omega$
Output Resistance (Hot)	$R_{OUT\_HOT}$	$T_C = 100^{\circ}\text{C}, I_{OUT} = 20\text{A}$	6.0	12.0	15.0	m $\Omega$
Switching Frequency	$f_{SW}$		<b>1.47</b>	1.52	<b>1.57</b>	MHz
Output Ripple Frequency	$f_{SW\_RP}$		<b>7.94</b>	3.04	<b>3.14</b>	MHz
MTBF		MIL-HDBK-217 Plus Parts Count; 25°C Ground Benign, Stationary, Indoors / Computer Profile		4.3		MHrs
		Telcordia Issue 2 - Method 1 Case 1; Ground Benign, Controlled		9.5		MHrs
VC Internal Resistor	$R_{VC-INT}$			0.56		k $\Omega$
<b>MVTM36BF072M017A00</b>						
No-Load Power Dissipation	$P_{NL}$	$V_{IN} = 26 - 50\text{V}$			<b>14.0</b>	W
Transfer Ratio	K	$K = V_{OUT} / V_{IN}, I_{OUT} = 0\text{A}$		1/5		V/V
Output Voltage	$V_{OUT}$	$V_{OUT} = V_{IN} \cdot K - I_{OUT} \cdot R_{OUT}$				V
Output Current (Average)	$I_{OUT\_AVG}$				<b>17</b>	A
Output Current (Peak)	$I_{OUT\_PK}$	$t_{PEAK} < 10\text{ms}, I_{OUT\_AVG} \leq 17\text{A}$			<b>25</b>	A
Efficiency (Ambient)	$\eta_{AMB}$	$V_{IN} = 36\text{V}, I_{OUT} = 17\text{A}$	95.3	95.9		%
		$V_{IN} = 26\text{V to } 55\text{V}, I_{OUT} = 17\text{A}$	92.0			
Output Resistance (Cold)	$R_{OUT\_COLD}$	$T_C = -40^{\circ}\text{C}, I_{OUT} = 17\text{A}$	3.3	5.6	7.8	m $\Omega$
Output Resistance (Ambient)	$R_{OUT\_AMB}$	$T_C = 25^{\circ}\text{C}, I_{OUT} = 17\text{A}$	5.0	7.8	10.0	m $\Omega$
Output Resistance (Hot)	$R_{OUT\_HOT}$	$T_C = 100^{\circ}\text{C}, I_{OUT} = 17\text{A}$	7.0	9.1	12.0	m $\Omega$
Switching Frequency	$f_{SW}$		<b>1.50</b>	1.55	<b>1.60</b>	MHz
Output Ripple Frequency	$f_{SW\_RP}$		<b>3.00</b>	3.10	<b>3.20</b>	MHz
MTBF		MIL-HDBK-217 Plus Parts Count; 25°C Ground Benign, Stationary, Indoors / Computer Profile		3.5		MHrs
		Telcordia Issue 2 - Method 1 Case 1; Ground Benign, Controlled		5.5		MHrs
VC Internal Resistor	$R_{VC-INT}$			0.56		k $\Omega$

**Model Specific Electrical Characteristics (Cont.)**

Specifications apply over all line and load conditions, unless otherwise noted; Boldface specifications apply over the temperature range of  $-55^{\circ}\text{C} < T_J < 125^{\circ}\text{C}$  (M-Grade); All other specifications are at  $T_J = 25^{\circ}\text{C}$  unless otherwise noted.

Attribute	Symbol	Conditions / Notes	Min	Typ	Max	Unit
<b>MVTM36BF090M013A00</b>						
No-Load Power Dissipation	$P_{NL}$	$V_{IN} = 26 - 50\text{V}$			<b>14.0</b>	W
Transfer Ratio	K	$K = V_{OUT} / V_{IN}, I_{OUT} = 0\text{A}$		1/4		V/V
Output Voltage	$V_{OUT}$	$V_{OUT} = V_{IN} \cdot K - I_{OUT} \cdot R_{OUT}$				V
Output Current (Average)	$I_{OUT\_AVG}$				<b>13</b>	A
Output Current (Peak)	$I_{OUT\_PK}$	$t_{PEAK} < 10\text{ms}, I_{OUT\_AVG} \leq 13\text{A}$			<b>19</b>	A
Efficiency (Ambient)	$\eta_{AMB}$	$V_{IN} = 36\text{V}, I_{OUT} = 13\text{A}$	93.8	95.3		%
		$V_{IN} = 26 - 50\text{V}, I_{OUT} = 13\text{A}$	93.5			
Output Resistance (Cold)	$R_{OUT\_COLD}$	$T_C = -40^{\circ}\text{C}, I_{OUT} = 13\text{A}$	2.0	5.5	9.5	m $\Omega$
Output Resistance (Ambient)	$R_{OUT\_AMB}$	$T_C = 25^{\circ}\text{C}, I_{OUT} = 13\text{A}$	3.9	8.9	13.4	m $\Omega$
Output Resistance (Hot)	$R_{OUT\_HOT}$	$T_C = 100^{\circ}\text{C}, I_{OUT} = 13\text{A}$	5.0	10.6	15.9	m $\Omega$
Switching Frequency	$f_{SW}$		<b>1.85</b>	1.95	<b>2.05</b>	MHz
Output Ripple Frequency	$f_{SW\_RP}$		<b>3.70</b>	3.90	<b>4.10</b>	MHz
MTBF		MIL-HDBK-217 Plus Parts Count; 25°C Ground Benign, Stationary, Indoors / Computer Profile		1.8		MHrs
		Telcordia Issue 2 - Method 1 Case 1; Ground Benign, Controlled		7.3		MHrs
VC Internal Resistor	$R_{VC\_INT}$			0.51		k $\Omega$
<b>MVTM36BF120M010A00</b>						
No-Load Power Dissipation	$P_{NL}$	$V_{IN} = 26 - 50\text{V}$			<b>10.5</b>	W
Transfer Ratio	K	$K = V_{OUT} / V_{IN}, I_{OUT} = 0\text{A}$		1/3		V/V
Output Voltage	$V_{OUT}$	$V_{OUT} = V_{IN} \cdot K - I_{OUT} \cdot R_{OUT}$				V
Output Current (Average)	$I_{OUT\_AVG}$				<b>10</b>	A
Output Current (Peak)	$I_{OUT\_PK}$	$t_{PEAK} < 10\text{ms}, I_{OUT\_AVG} \leq 10\text{A}$			<b>15</b>	A
Efficiency (Ambient)	$\eta_{AMB}$	$V_{IN} = 36\text{V}, I_{OUT} = 10\text{A}$	94.2	94.9		%
		$V_{IN} = 26 - 50\text{V}, I_{OUT} = 10\text{A}$	90.0			
Output Resistance (Cold)	$R_{OUT\_COLD}$	$T_C = -40^{\circ}\text{C}, I_{OUT} = 10\text{A}$	12.8	19.7	26.5	m $\Omega$
Output Resistance (Ambient)	$R_{OUT\_AMB}$	$T_C = 25^{\circ}\text{C}, I_{OUT} = 10\text{A}$	20.4	26.5	32.6	m $\Omega$
Output Resistance (Hot)	$R_{OUT\_HOT}$	$T_C = 100^{\circ}\text{C}, I_{OUT} = 10\text{A}$	23.1	29.2	35.2	m $\Omega$
Switching Frequency	$f_{SW}$		<b>1.56</b>	1.65	<b>1.74</b>	MHz
Output Ripple Frequency	$f_{SW\_RP}$		<b>3.12</b>	3.30	<b>3.48</b>	MHz
MTBF		MIL-HDBK-217 Plus Parts Count; 25°C Ground Benign, Stationary, Indoors / Computer Profile		3.8		MHrs
		Telcordia Issue 2 - Method 1 Case 1; Ground Benign, Controlled		5.6		MHrs
VC Internal Resistor	$R_{VC\_INT}$			2.0		k $\Omega$

**Model Specific Electrical Characteristics (Cont.)**

Specifications apply over all line and load conditions, unless otherwise noted; Boldface specifications apply over the temperature range of  $-55^{\circ}\text{C} < T_J < 125^{\circ}\text{C}$  (M-Grade); All other specifications are at  $T_J = 25^{\circ}\text{C}$  unless otherwise noted.

Attribute	Symbol	Conditions / Notes	Min	Typ	Max	Unit
<b>MVTM36BF180M007A00</b>						
No-Load Power Dissipation	$P_{NL}$	$V_{IN} = 26 - 50\text{V}$			<b>13.5</b>	W
Transfer Ratio	K	$K = V_{OUT} / V_{IN}, I_{OUT} = 0\text{A}$		1/2		V/V
Output Voltage	$V_{OUT}$	$V_{OUT} = V_{IN} \cdot K - I_{OUT} \cdot R_{OUT}$				V
Output Current (Average)	$I_{OUT\_AVG}$				<b>7</b>	A
Output Current (Peak)	$I_{OUT\_PK}$	$t_{PEAK} < 10\text{ms}, I_{OUT\_AVG} \leq 7\text{A}$			<b>10</b>	A
Efficiency (Ambient)	$\eta_{AMB}$	$V_{IN} = 36\text{V}, I_{OUT} = 7\text{A}$	93.0	94.0		%
		$V_{IN} = 26 - 50\text{V}, I_{OUT} = 7\text{A}$	92.0			
Output Resistance (Cold)	$R_{OUT\_COLD}$	$T_C = -40^{\circ}\text{C}, I_{OUT} = 7\text{A}$	19.7	40.0	60.7	m $\Omega$
Output Resistance (Ambient)	$R_{OUT\_AMB}$	$T_C = 25^{\circ}\text{C}, I_{OUT} = 7\text{A}$	30.0	55.0	75.0	m $\Omega$
Output Resistance (Hot)	$R_{OUT\_HOT}$	$T_C = 100^{\circ}\text{C}, I_{OUT} = 7\text{A}$	35.0	60.0	90.0	m $\Omega$
Switching Frequency	$f_{SW}$		<b>1.68</b>	1.77	<b>1.86</b>	MHz
Output Ripple Frequency	$f_{SW\_RP}$		<b>3.36</b>	3.54	<b>3.72</b>	MHz
MTBF		MIL-HDBK-217 Plus Parts Count; 25°C Ground Benign, Stationary, Indoors / Computer Profile		3.8		MHrs
		Telcordia Issue 2 - Method 1 Case 1; Ground Benign, Controlled		5.7		MHrs
VC Internal Resistor	$R_{VC-INT}$			0.51		k $\Omega$
<b>MVTM36BF240M005A00</b>						
No-Load Power Dissipation	$P_{NL}$	$V_{IN} = 26 - 50\text{V}$			<b>8.5</b>	W
Transfer Ratio	K	$K = V_{OUT} / V_{IN}, I_{OUT} = 0\text{A}$		2/3		V/V
Output Voltage	$V_{OUT}$	$V_{OUT} = V_{IN} \cdot K - I_{OUT} \cdot R_{OUT}$				V
Output Current (Average)	$I_{OUT\_AVG}$				<b>5</b>	A
Output Current (Peak)	$I_{OUT\_PK}$	$t_{PEAK} < 10\text{ms}, I_{OUT\_AVG} \leq 5\text{A}$			<b>7.5</b>	A
Efficiency (Ambient)	$\eta_{AMB}$	$V_{IN} = 36\text{V}, I_{OUT} = 5\text{A}$	93.5	96.0		%
		$V_{IN} = 26 - 50\text{V}, I_{OUT} = 5\text{A}$	93.0			
Output Resistance (Cold)	$R_{OUT\_COLD}$	$T_C = -40^{\circ}\text{C}, I_{OUT} = 5\text{A}$	40.0	51.4	70.0	m $\Omega$
Output Resistance (Ambient)	$R_{OUT\_AMB}$	$T_C = 25^{\circ}\text{C}, I_{OUT} = 5\text{A}$	64.0	86.0	120.0	m $\Omega$
Output Resistance (Hot)	$R_{OUT\_HOT}$	$T_C = 100^{\circ}\text{C}, I_{OUT} = 5\text{A}$	85.0	102.0	135	m $\Omega$
Switching Frequency	$f_{SW}$		<b>1.57</b>	1.60	<b>1.63</b>	MHz
Output Ripple Frequency	$f_{SW\_RP}$		<b>3.14</b>	3.20	<b>3.26</b>	MHz
MTBF		MIL-HDBK-217 Plus Parts Count; 25°C Ground Benign, Stationary, Indoors / Computer Profile		3.8		MHrs
		Telcordia Issue 2 - Method 1 Case 1; Ground Benign, Controlled		5.6		MHrs
VC Internal Resistor	$R_{VC-INT}$			2.0		k $\Omega$

**Model Specific Electrical Characteristics (Cont.)**

Specifications apply over all line and load conditions, unless otherwise noted; Boldface specifications apply over the temperature range of  $-55^{\circ}\text{C} < T_J < 125^{\circ}\text{C}$  (M-Grade); All other specifications are at  $T_J = 25^{\circ}\text{C}$  unless otherwise noted.

Attribute	Symbol	Conditions / Notes	Min	Typ	Max	Unit
<b>MVTM36BF360M003A00</b>						
No-Load Power Dissipation	$P_{NL}$	$V_{IN} = 26 - 50\text{V}$			<b>9.0</b>	W
Transfer Ratio	K	$K = V_{OUT} / V_{IN}, I_{OUT} = 0\text{A}$		1		V/V
Output Voltage	$V_{OUT}$	$V_{OUT} = V_{IN} \cdot K - I_{OUT} \cdot R_{OUT}$				V
Output Current (Average)	$I_{OUT\_AVG}$				<b>3</b>	A
Output Current (Peak)	$I_{OUT\_PK}$	$t_{PEAK} < 10\text{ms}, I_{OUT\_AVG} \leq 3\text{A}$			<b>4.5</b>	A
Efficiency (Ambient)	$\eta_{AMB}$	$V_{IN} = 36\text{V}, I_{OUT} = 3\text{A}$	95.3	96.0		%
		$V_{IN} = 26 - 50\text{V}, I_{OUT} = 3\text{A}$	93.3			
Output Resistance (Cold)	$R_{OUT\_COLD}$	$T_C = -40^{\circ}\text{C}, I_{OUT} = 3\text{A}$	30	80	175	m $\Omega$
Output Resistance (Ambient)	$R_{OUT\_AMB}$	$T_C = 25^{\circ}\text{C}, I_{OUT} = 3\text{A}$	72	100	168	m $\Omega$
Output Resistance (Hot)	$R_{OUT\_HOT}$	$T_C = 100^{\circ}\text{C}, I_{OUT} = 3\text{A}$	120	160	228	m $\Omega$
Switching Frequency	$f_{SW}$		<b>1.64</b>	1.67	<b>1.70</b>	MHz
Output Ripple Frequency	$f_{SW\_RP}$		<b>3.28</b>	3.34	<b>3.40</b>	MHz
MTBF		MIL-HDBK-217 Plus Parts Count; $25^{\circ}\text{C}$ Ground Benign, Stationary, Indoors / Computer Profile		3.8		MHrs
		Telcordia Issue 2 - Method 1 Case 1; Ground Benign, Controlled		5.6		MHrs
VC Internal Resistor	$R_{VC\_INT}$			2.0		k $\Omega$

**Model Specific Electrical Characteristics (Cont.)**

Specifications apply over all line and load conditions, unless otherwise noted; Boldface specifications apply over the temperature range of  $-55^{\circ}\text{C} < T_J < 125^{\circ}\text{C}$  (M-Grade); All other specifications are at  $T_J = 25^{\circ}\text{C}$  unless otherwise noted.

Attribute	Symbol	Conditions / Notes	Min	Typ	Max	Unit
<b>MVTM36BH030M025A00</b>						
No-Load Power Dissipation	$P_{NL}$	$V_{IN} = 26 - 50\text{V}$			<b>5.0</b>	W
Transfer Ratio	K	$K = V_{OUT} / V_{IN}, I_{OUT} = 0\text{A}$		1/12		V/V
Output Voltage	$V_{OUT}$	$V_{OUT} = V_{IN} \cdot K - I_{OUT} \cdot R_{OUT}$				V
Output Current (Average)	$I_{OUT\_AVG}$				<b>25.0</b>	A
Output Current (Peak)	$I_{OUT\_PK}$	$t_{PEAK} < 10\text{ms}, I_{OUT\_AVG} \leq 25\text{A}$			<b>37.5</b>	A
Efficiency (Ambient)	$\eta_{AMB}$	$V_{IN} = 36\text{V}, I_{OUT} = 25\text{A}$	88.5	90.8		%
		$V_{IN} = 26 - 50\text{V}, I_{OUT} = 25\text{A}$	85.5			
Output Resistance (Cold)	$R_{OUT\_COLD}$	$T_C = -40^{\circ}\text{C}, I_{OUT} = 25\text{A}$	2.0	5.3	8.5	m $\Omega$
Output Resistance (Ambient)	$R_{OUT\_AMB}$	$T_C = 25^{\circ}\text{C}, I_{OUT} = 25\text{A}$	4.5	7.3	10.0	m $\Omega$
Output Resistance (Hot)	$R_{OUT\_HOT}$	$T_C = 100^{\circ}\text{C}, I_{OUT} = 25\text{A}$	5.0	8.0	12.0	m $\Omega$
Switching Frequency	$f_{SW}$		<b>1.50</b>	1.65	<b>1.80</b>	MHz
Output Ripple Frequency	$f_{SW\_RP}$		<b>3.00</b>	3.30	<b>3.60</b>	MHz
MTBF		MIL-HDBK-217 Plus Parts Count; $25^{\circ}\text{C}$ Ground Benign, Stationary, Indoors / Computer Profile		4.5		MHrs
VC Internal Resistor	$R_{VC\_INT}$			8.87		k $\Omega$

**Current Monitor: IM**

- The IM pin provides a DC analog voltage proportional to the output current of the VTM.

Signal Type	State	Attribute	Symbol	Conditions / Notes	Min	Typ	Max	Unit
<b>Analog Input</b>	Steady	IM Voltage (No Load)	$V_{IM\_NL}$	$T_C = 25^{\circ}\text{C}, V_{IN} = 42\text{V}, I_{OUT} = 0\text{A}$	0.30	0.32	0.38	V
		IM Voltage (50%)	$V_{IM\_50\%}$	$T_C = 25^{\circ}\text{C}, V_{IN} = 42\text{V}, I_{OUT} = 12.5\text{A}$		0.94		V
		IM Voltage (Full Load)	$V_{IM\_FL}$	$T_C = 25^{\circ}\text{C}, V_{IN} = 42\text{V}, I_{OUT} = 25\text{A}$		1.80		V
		IM Gain	$A_{IM}$	$T_C = 25^{\circ}\text{C}, V_{IN} = 42\text{V}, I_{OUT} > 12.5\text{A}$		69		mV/A
		IM Resistance (External)	$R_{IM\_EXT}$			<b>2.5</b>		

**Model Specific Electrical Characteristics (Cont.)**

Specifications apply over all line and load conditions, unless otherwise noted; Boldface specifications apply over the temperature range of  $-55^{\circ}\text{C} < T_J < 125^{\circ}\text{C}$  (M-Grade); All other specifications are at  $T_J = 25^{\circ}\text{C}$  unless otherwise noted.

Attribute	Symbol	Conditions / Notes	Min	Typ	Max	Unit
<b>MVTM36BH045M020A00</b>						
No-Load Power Dissipation	$P_{NL}$	$V_{IN} = 26 - 50\text{V}$			<b>5.6</b>	W
Transfer Ratio	K	$K = V_{OUT} / V_{IN}, I_{OUT} = 0\text{A}$		1/8		V/V
Output Voltage	$V_{OUT}$	$V_{OUT} = V_{IN} \cdot K - I_{OUT} \cdot R_{OUT}$				V
Output Current (Average)	$I_{OUT\_AVG}$				<b>20</b>	A
Output Current (Peak)	$I_{OUT\_PK}$	$t_{PEAK} < 10\text{ms}, I_{OUT\_AVG} \leq 20\text{A}$			<b>30</b>	A
Efficiency (Ambient)	$\eta_{AMB}$	$V_{IN} = 48\text{V}, I_{OUT} = 20\text{A}$	91.0	92.9		%
		$V_{IN} = 26\text{V to } 55\text{V}, I_{OUT} = 20\text{A}$	89.5			
Output Resistance (Cold)	$R_{OUT\_COLD}$	$T_C = -40^{\circ}\text{C}, I_{OUT} = 20\text{A}$	5.0	8.2	13.0	m $\Omega$
Output Resistance (Ambient)	$R_{OUT\_AMB}$	$T_C = 25^{\circ}\text{C}, I_{OUT} = 20\text{A}$	7.0	10.8	15.0	m $\Omega$
Output Resistance (Hot)	$R_{OUT\_HOT}$	$T_C = 100^{\circ}\text{C}, I_{OUT} = 20\text{A}$	9.0	13.2	18.0	m $\Omega$
Switching Frequency	$f_{SW}$		<b>1.37</b>	1.50	<b>1.63</b>	MHz
Output Ripple Frequency	$f_{SW\_RP}$		<b>2.74</b>	3.00	<b>3.26</b>	MHz
MTBF		MIL-HDBK-217 Plus Parts Count; $25^{\circ}\text{C}$ Ground Benign, Stationary, Indoors / Computer Profile		6.0		MHrs
VC Internal Resistor	$R_{VC\_INT}$			4.64		k $\Omega$

**Current Monitor: IM**

- The IM pin provides a DC analog voltage proportional to the output current of the VTM.

Signal Type	State	Attribute	Symbol	Conditions / Notes	Min	Typ	Max	Unit
<b>Analog Input</b>	Steady	IM Voltage (No Load)	$V_{IM\_NL}$	$T_C = 25^{\circ}\text{C}, V_{IN} = 48\text{V}, I_{OUT} = 0\text{A}$	0.27	0.33	0.37	V
		IM Voltage (50%)	$V_{IM\_50\%}$	$T_C = 25^{\circ}\text{C}, V_{IN} = 48\text{V}, I_{OUT} = 10\text{A}$		1.0		V
		IM Voltage (Full Load)	$V_{IM\_FL}$	$T_C = 25^{\circ}\text{C}, V_{IN} = 48\text{V}, I_{OUT} = 20\text{A}$		1.91		V
		IM Gain	$A_{IM}$	$T_C = 25^{\circ}\text{C}, V_{IN} = 48\text{V}, I_{OUT} > 10\text{A}$		91		mV/A
		IM Resistance (External)	$R_{IM\_EXT}$			<b>2.5</b>		

**Model Specific Electrical Characteristics (Cont.)**

Specifications apply over all line and load conditions, unless otherwise noted; Boldface specifications apply over the temperature range of  $-55^{\circ}\text{C} < T_J < 125^{\circ}\text{C}$  (M-Grade); All other specifications are at  $T_J = 25^{\circ}\text{C}$  unless otherwise noted.

Attribute	Symbol	Conditions / Notes	Min	Typ	Max	Unit
<b>MVTM36BH090M010A00</b>						
No-Load Power Dissipation	$P_{NL}$	$V_{IN} = 26 - 50\text{V}$			<b>5.2</b>	W
Transfer Ratio	K	$K = V_{OUT} / V_{IN}, I_{OUT} = 0\text{A}$		1/4		V/V
Output Voltage	$V_{OUT}$	$V_{OUT} = V_{IN} \cdot K - I_{OUT} \cdot R_{OUT}$				V
Output Current (Average)	$I_{OUT\_AVG}$				<b>10</b>	A
Output Current (Peak)	$I_{OUT\_PK}$	$t_{PEAK} < 10\text{ms}, I_{OUT\_AVG} \leq 10\text{A}$			<b>15</b>	A
Efficiency (Ambient)	$\eta_{AMB}$	$V_{IN} = 36\text{V}, I_{OUT} = 10\text{A}$	92.0	93.6		%
		$V_{IN} = 26 - 50\text{V}, I_{OUT} = 10\text{A}$	90.0			
Output Resistance (Cold)	$R_{OUT\_COLD}$	$T_C = -40^{\circ}\text{C}, I_{OUT} = 10\text{A}$	20.0	27.0	35.0	m $\Omega$
Output Resistance (Ambient)	$R_{OUT\_AMB}$	$T_C = 25^{\circ}\text{C}, I_{OUT} = 10\text{A}$	28.0	36.2	45.0	m $\Omega$
Output Resistance (Hot)	$R_{OUT\_HOT}$	$T_C = 100^{\circ}\text{C}, I_{OUT} = 10\text{A}$	35.0	44.4	55.0	m $\Omega$
Switching Frequency	$f_{SW}$		<b>1.60</b>	1.75	<b>1.90</b>	MHz
Output Ripple Frequency	$f_{SW\_RP}$		<b>3.20</b>	3.50	<b>3.80</b>	MHz
MTBF		MIL-HDBK-217 Plus Parts Count; $25^{\circ}\text{C}$ Ground Benign, Stationary, Indoors / Computer Profile		4.5		MHrs
VC Internal Resistor	$R_{VC\_INT}$			2.05		k $\Omega$

**Current Monitor: IM**

- The IM pin provides a DC analog voltage proportional to the output current of the VTM.

Signal Type	State	Attribute	Symbol	Conditions / Notes	Min	Typ	Max	Unit
<b>Analog Input</b>	Steady	IM Voltage (No Load)	$V_{IM\_NL}$	$T_C = 25^{\circ}\text{C}, V_{IN} = 48\text{V}, I_{OUT} = 0\text{A}$	0.28	0.35	0.42	V
		IM Voltage (50%)	$V_{IM\_50\%}$	$T_C = 25^{\circ}\text{C}, V_{IN} = 48\text{V}, I_{OUT} = 5\text{A}$		0.90		V
		IM Voltage (Full Load)	$V_{IM\_FL}$	$T_C = 25^{\circ}\text{C}, V_{IN} = 48\text{V}, I_{OUT} = 10\text{A}$		1.68		V
		IM Gain	$A_{IM}$	$T_C = 25^{\circ}\text{C}, V_{IN} = 48\text{V}, I_{OUT} > 5\text{A}$		156		mV/A
		IM Resistance (External)	$R_{IM\_EXT}$			<b>2.5</b>		

## Signal Characteristics

Specifications apply over all line and load conditions, unless otherwise noted; Boldface specifications apply over the temperature range of  $-55^{\circ}\text{C} < T_J < 125^{\circ}\text{C}$  (M-Grade); All other specifications are at  $T_J = 25^{\circ}\text{C}$  unless otherwise noted.

VTM Control: VC								
<ul style="list-style-type: none"> <li>Used to wake up powertrain circuit.</li> <li>A minimum of 12V must be applied indefinitely for <math>V_{IN} \leq 26\text{V}</math> to ensure normal operation.</li> <li>VC slew rate must be within range for a successful start.</li> <li>PRM™ VC can be used as valid wake-up signal source.</li> <li>VC voltage may be continuously applied; there will be minimal VC current drawn when <math>V_{IN} \geq 26\text{V}</math> and <math>VC \leq 13</math>.</li> <li>Internal resistance used in adaptive loop compensation</li> </ul>								
Signal Type	State	Attribute	Symbol	Conditions / Notes	Min	Typ	Max	Unit
Analog Input	Steady	External VC Voltage	$V_{VC\_EXT}$	Required for start up, and operation below 26V.	<b>12</b>		<b>16.5</b>	V
		VC Current Draw Threshold	$V_{VC\_TH}$	Low VC current draw for $V_{IN} > 26\text{V}$		13		V
		VC Current Draw	$I_{VC}$	$VC = 13\text{V}, V_{IN} = 0\text{V}$			<b>200</b>	
	$VC = 13\text{V}, V_{IN} > 26\text{V}$				22.5			
	$VC = 16.5\text{V}, V_{IN} > 26\text{V}$				32			
	Start Up	VC Slew Rate	$dVC/dt$	Required for proper start up	<b>0.02</b>		<b>0.25</b>	$\text{V}/\mu\text{s}$
		VC Inrush Current	$I_{INR\_VC}$	$VC = 16.5\text{V}, dVC/dt = 0.25\text{V}/\mu\text{s}$			<b>2</b>	A
Transitional	VC Output Turn-On Delay	$t_{ON}$	$V_{IN}$ pre-applied, PC floating, VC enable; $C_{PC} = 0\mu\text{F}, C_{OUT} = 0\mu\text{F}$				<b>500</b>	$\mu\text{s}$
	VC To PC Delay	$t_{VC\_PC}$	$VC = 12\text{V}$ to PC high, $V_{IN} = 0\text{V}, dVC/dt = 0.25\text{V}/\mu\text{s}$		10	<b>25</b>	$\mu\text{s}$	
Primary Control: PC								
<ul style="list-style-type: none"> <li>The PC pin enables and disables the VTM. When held below 2V, the VTM will be disabled.</li> <li>PC pin outputs 5V during normal operation. PC pin is equal to 2.5V during fault mode given <math>V_{IN} \geq 26\text{V}</math> and <math>VC \geq 12\text{V}</math>.</li> <li>After successful start-up and under no fault condition, PC can be used as a 5V regulated voltage source with a 2mA maximum current.</li> <li>Module will shutdown when pulled low with an impedance less than 400<math>\Omega</math>.</li> <li>In an array of VTMs, connect PC pin to synchronize start up.</li> <li>PC pin cannot sink current and will not disable other modules during fault mode.</li> </ul>								
Signal Type	State	Attribute	Symbol	Conditions / Notes	Min	Typ	Max	Unit
Analog Input	Steady	PC Voltage	$V_{PC}$		<b>4.7</b>	5.0	<b>5.3</b>	V
		PC Source Current	$I_{PC\_OP}$				2	mA
		PC Resistance (Internal)	$R_{PC\_INT}$	Internal pull-down resistor	<b>50</b>	150	<b>400</b>	$\text{k}\Omega$
	Start Up	PC Source Current	$I_{PC\_EN}$		<b>50</b>	100	<b>300</b>	$\mu\text{A}$
		PC Capacitance (Internal)	$C_{PC\_INT}$				<b>50</b>	pF
		PC Resistance (External)	$R_{PC\_EXT}$		<b>60</b>			$\text{k}\Omega$
Digital Input / Output	Enable	PC Voltage (Enable)	$V_{PC\_EN}$		<b>2</b>	2.5	<b>3</b>	V
	Disable	PC Voltage (Disable)	$V_{PC\_DIS}$				<b>2</b>	V
		PC Pull Down Current	$I_{PC\_PD}$		<b>5.1</b>			mA
	Transitional	PC Disable Time	$t_{PC\_DIS\_T}$				4	$\mu\text{s}$
		PC Fault Response Time	$t_{FR\_PC}$	From fault to $PC = 2\text{V}$			100	$\mu\text{s}$

### Signal Characteristics (Cont.)

Specifications apply over all line and load conditions, unless otherwise noted; Boldface specifications apply over the temperature range of  $-55^{\circ}\text{C} < T_J < 125^{\circ}\text{C}$  (M-Grade); All other specifications are at  $T_J = 25^{\circ}\text{C}$  unless otherwise noted.

Temperature Monitor: TM								
<ul style="list-style-type: none"> <li>The TM pin monitors the internal temperature of the VTM controller IC within an accuracy of <math>\pm 5^{\circ}\text{C}</math>.</li> <li>Can be used as a "Power Good" flag to verify that the VTM is operating.</li> <li>The TM pin has a room temperature set point of 3V (at <math>27^{\circ}\text{C}</math>) and approximate gain of <math>10\text{mV}/^{\circ}\text{C}</math>.</li> </ul>								
Signal Type	State	Attribute	Symbol	Conditions / Notes	Min	Typ	Max	Unit
Analog Output	Steady	TM Voltage	$V_{\text{TM\_AMB}}$	$T_J$ controller = $27^{\circ}\text{C}$	2.95	3.00	3.05	V
		TM Source Current	$I_{\text{TM}}$				<b>100</b>	$\mu\text{A}$
		TM Gain	$A_{\text{TM}}$			10		$\text{mV}/^{\circ}\text{C}$
Digital Output (Fault Flag)	Disable	TM Voltage	$V_{\text{TM\_DIS}}$			0		V
	Transitional	TM Resistance (Internal)	$R_{\text{TM\_INT}}$	Internal pull-down resistor	<b>25</b>	40	<b>50</b>	$\text{k}\Omega$
		TM Capacitance (External)	$C_{\text{TM\_EXT}}$				<b>50</b>	pF
		TM Fault Response Time	$t_{\text{FR\_TM}}$	From fault to TM = 1.5V		10		$\mu\text{s}$

Timing Diagram

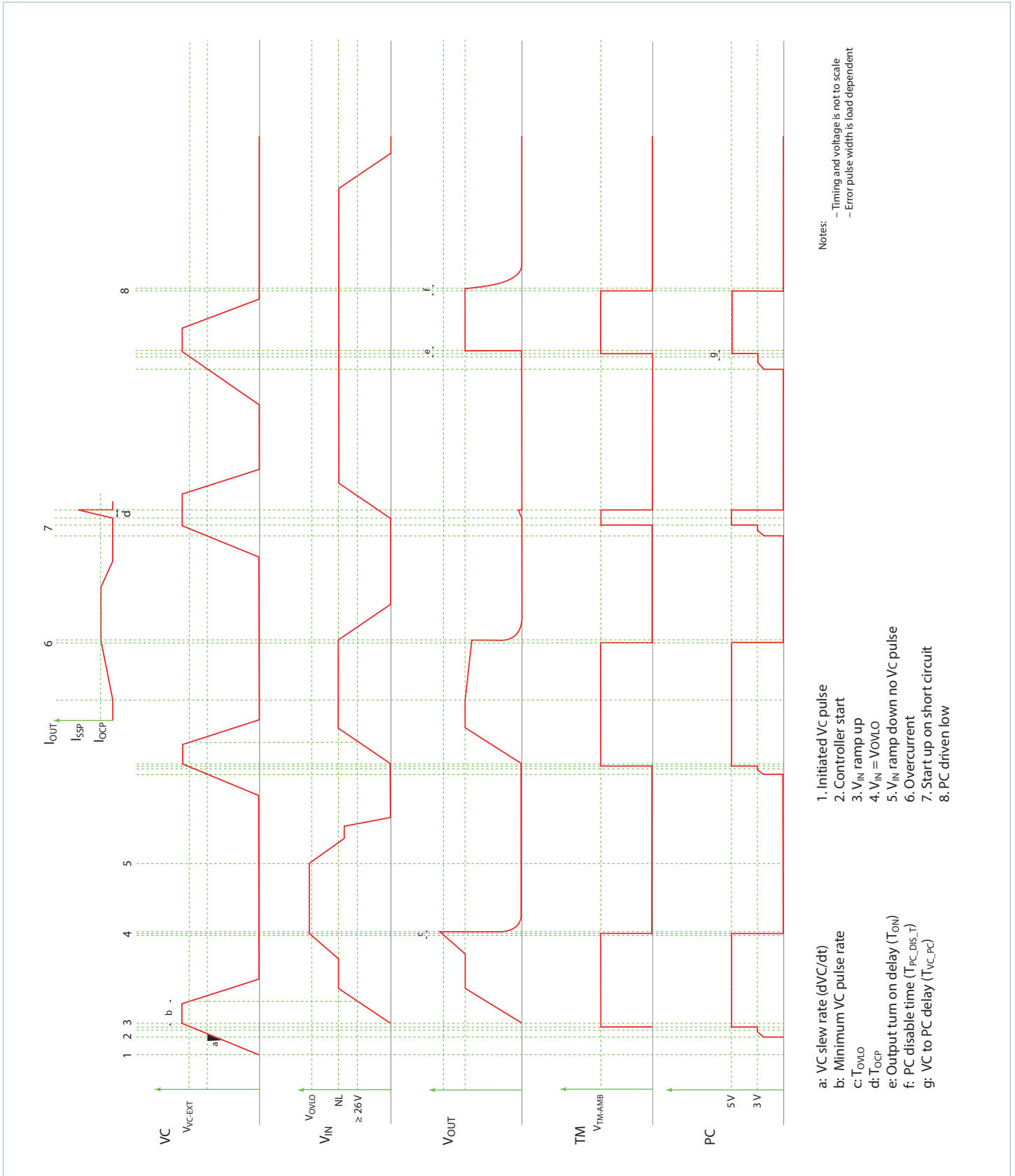

## General Characteristics

Specifications apply over all line and load conditions, unless otherwise noted; Boldface specifications apply over the temperature range of  $-55^{\circ}\text{C} < T_J < 125^{\circ}\text{C}$  (M-Grade); All other specifications are at  $T_J = 25^{\circ}\text{C}$  unless otherwise noted.

Attribute	Symbol	Conditions Notes	Min	Typ	Max	Unit
<b>Mechanical</b>						
<b>Full VIC</b>						
Length	L		32.25 [1.270]	32.5 [1.280]	32.75 [1.289]	mm [in]
Width	W		21.75 [0.856]	22.0 [0.866]	22.25 [0.876]	mm [in]
Height	H		6.48 [0.255]	6.73 [0.265]	6.98 [0.275]	mm [in]
Volume	Vol	No heat sink		4.81 [0.294]		cm <sup>3</sup> [in <sup>3</sup> ]
Weight	W			15.0 [0.53]		g [oz]
<b>Half VIC</b>						
Length	L		21.7 [0.85]	22.0 [0.87]	22.3 [0.88]	mm [in]
Width	W		16.4 [0.64]	16.5 [0.65]	16.6 [0.66]	mm [in]
Height	H		6.48 [0.255]	6.73 [0.265]	6.98 [0.275]	mm [in]
Volume	Vol	No heat sink		2.44 [0.150]		cm <sup>3</sup> [in <sup>3</sup> ]
Weight	W			8.0 [0.28]		g [oz]
Lead Finish		Nickel	0.51		2.03	μm
		Palladium	0.02		0.15	
		Gold	0.003		0.051	
<b>Thermal</b>						
Operating Temperature	$T_J$		-55		125	°C
Thermal Resistance (Full VIC)	$\theta_{JC}$	Isothermal heat sink and isothermal internal PCB		1		°C/W
Thermal Resistance (Half VIC)	$\theta_{JC}$	Isothermal heat sink and isothermal internal PCB		2.2		°C/W
<b>Assembly</b>						
Storage Temperature	$T_{ST}$		-65		125	°C
ESD Withstand	$ESD_{HBM}$	Human Body Model Component Level ANSI ESDA JEDEC JS-001-2012, Class 1C 1000 to <2000 V	1000			$V_{DC}$
	$ESD_{CDM}$	Field Induced Change Device Model JESD22-C101E, Class II 200 to <500 V	200			
<b>Soldering</b>						
Peak Temperature During Reflow		MSL 4 (Datecode 1528 and later)			245	°C
Peak Time above 217°C				60	90	s
Peak Heating Rate During Reflow				1.5	3	°C/s
Peak Cooling Rate Post Reflow				1.5	6	°C/s
<b>Safety</b>						
Isolation Voltage (Hipot)	$V_{HIPOT}$		<b>2250</b>			$V_{DC}$
Isolation Resistance	$R_{IN\_OUT}$		<b>10</b>			MΩ
Agency Approvals / Standards		cTÜVus				
		cURus				
		CE Marked for low voltage directive and RoHS recast directive, as applicable				

## Using the Control Signals VC, PC, TM

The **VTM Control (VC)** pin is an input pin which powers the internal VCC circuitry when within the specified voltage range of 12 – 16.5V. This voltage is required in order for the VTM module to start, and must be applied as long as the input is below 26V. In order to ensure a proper start, the slew rate of the applied voltage must be within the specified range.

Some additional notes on the using the VC pin:

- In most applications, the VTM module will be powered by an upstream PRM™ regulator which provides a 10ms VC pulse during start up. In these applications the VC pins of the PRM regulator and VTM current multiplier should be tied together.
- The VC voltage can be applied indefinitely allowing for continuous operation down to  $0V_{IN}$ .
- The fault response of the VTM module is latching. A positive edge on VC is required in order to restart the unit. If VC is continuously applied the PC pin may be toggled to restart the VTM module.

**Primary Control (PC)** pin can be used to accomplish the following functions:

- **Delayed start:** Upon the application of VC, the PC pin will source a constant 100 $\mu$ A current to the internal RC network. Adding an external capacitor will allow further delay in reaching the 2.5V threshold for module start.
- **Auxiliary voltage source:** Once enabled in regular operational conditions (no fault), each VTM PC provides a regulated 5V, 2mA voltage source.
- **Output disable:** PC pin can be actively pulled down in order to disable the module. Pull-down impedance shall be lower than 400 $\Omega$ .
- **Fault detection flag:** The PC 5V voltage source is internally turned off as soon as a fault is detected. It is important to notice that PC doesn't have current sink capability. Therefore, in an array, PC line will not be capable of disabling neighboring modules if a fault is detected.
- **Fault reset:** PC may be toggled to restart the unit if VC is continuously applied.

**Temperature Monitor (TM)** pin provides a voltage proportional to the absolute temperature of the converter control IC.

It can be used to accomplish the following functions:

- **Monitor the control IC temperature:** The temperature in Kelvin is equal to the voltage on the TM pin scaled by 100. (i.e., 3.0V = 300K = 27°C). If a heat sink is applied, TM can be used to thermally protect the system.
- **Fault detection flag:** The TM voltage source is internally turned off as soon as a fault is detected. For system monitoring purposes (microcontroller interface) faults are detected on falling edges of TM signal.

## Start-Up Behavior

Depending on the sequencing of the VC with respect to the input voltage, the behavior during start up will vary as follows:

- **Normal operation (VC applied prior to  $V_{IN}$ ):** In this case the controller is active prior to ramping the input. When the input voltage is applied, the VTM module output voltage will track the input. The inrush current is determined by the input voltage rate of rise and output capacitance. If the VC voltage is removed prior to the input reaching 26V, the VTM may shut down.
- **Stand-alone operation (VC applied after  $V_{IN}$ ):** In this case the VTM output will begin to rise upon the application of the VC voltage. A soft-start circuit may vary the output rate of rise in order to limit the inrush current to its maximum level. When starting into high capacitance or a short, the output current will be limited for a maximum of 900 $\mu$ s. After this period, the Adaptive Soft-Start Circuit will time out and the VTM module may shut down. No restart will be attempted until VC is re-applied or PC is toggled. To ensure a successful start in this mode of operation, an additional capacitance on the output of the VTM should be kept to a minimum.

## Thermal Considerations

VI Chip® products are multi-chip modules whose temperature distribution varies greatly for each part number as well as with the input / output conditions, thermal management and environmental conditions. Maintaining the top of the VTM case to less than 100°C will keep all junctions within the VI Chip module below 125°C for most applications.

The percent of total heat dissipated through the top surface versus through the J-lead is entirely dependent on the particular mechanical and thermal environment. The heat dissipated through the top surface is typically 60%. The heat dissipated through the J-lead onto the PCB board surface is typically 40%. Use 100% top surface dissipation when designing for a conservative cooling solution.

It is not recommended to use a VI Chip module for an extended period of time at full load without proper heat sinking.

## Sine Amplitude Converter™ Point-of-Load Conversion

The Sine Amplitude Converter (SAC™) uses a high frequency resonant tank to move energy from input to output. The resonant LC tank, operated at high frequency, is amplitude modulated as function of input voltage and output current. A small amount of capacitance embedded in the input and output stages

of the module is sufficient for full functionality and is key to achieving power density.

A typical SAC can be simplified into the following model:

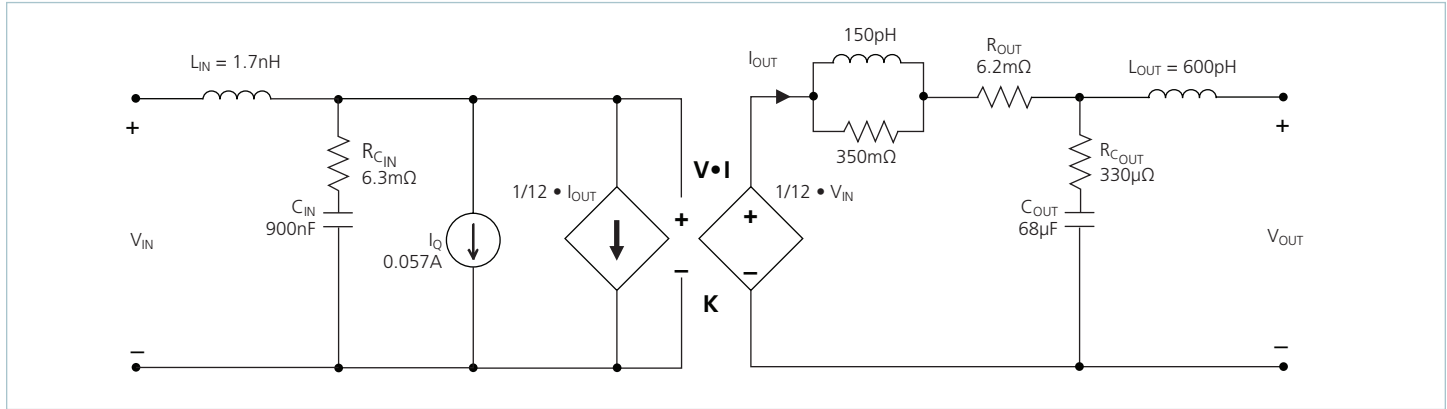

Figure 1 — VI Chip® module AC model (MVTM48EH040M025A00 shown)

At no load:

$$V_{OUT} = V_{IN} \cdot K \quad (1)$$

K represents the “turns ratio” of the SAC.  
Rearranging Equation 1:

$$K = \frac{V_{OUT}}{V_{IN}} \quad (2)$$

In the presence of load,  $V_{OUT}$  is represented by:

$$V_{OUT} = V_{IN} \cdot K - I_{OUT} \cdot R_{OUT} \quad (3)$$

and  $I_{OUT}$  is represented by:

$$I_{OUT} = \frac{I_{IN} - I_Q}{K} \quad (4)$$

$R_{OUT}$  represents the impedance of the SAC, and is a function of the  $R_{DSON}$  of the input and output MOSFETs and the winding resistance of the power transformer.  $I_Q$  represents the quiescent current of the SAC control and gate drive circuitry.

The use of DC voltage transformation provides additional interesting attributes. Assuming that  $R_{OUT} = 0\Omega$  and  $I_Q = 0A$ , Equation 3 now becomes Equation 1 and is essentially load independent, resistor R is now placed in series with  $V_{IN}$  as shown in Figure 2.

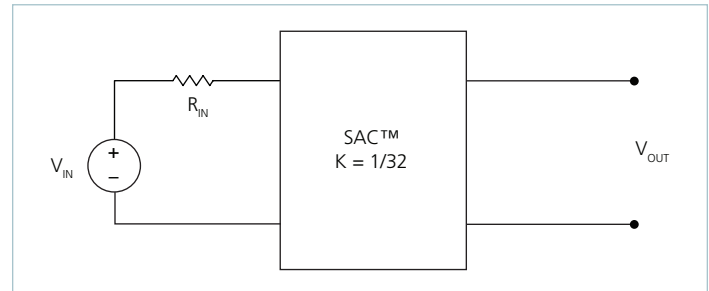

Figure 2 —  $K = 1/32$  Sine Amplitude Converter™ with series input resistor

The relationship between  $V_{IN}$  and  $V_{OUT}$  becomes:

$$V_{OUT} = (V_{IN} - I_{IN} \cdot R) \cdot K \quad (5)$$

Substituting the simplified version of Equation 4 ( $I_Q$  is assumed = 0A) into Equation 5 yields:

$$V_{OUT} = V_{IN} \cdot K - I_{OUT} \cdot R \cdot K^2 \quad (6)$$

This is similar in form to Equation 3, where  $R_{OUT}$  is used to represent the characteristic impedance of the SAC™. However, in this case a real R on the input side of the SAC is effectively scaled by  $K^2$  with respect to the output.

Assuming that  $R = 1\Omega$ , the effective R as seen from the secondary side is  $0.98m\Omega$ , with  $K = 1/32$  as shown in Figure 2.

A similar exercise should be performed with the addition of a capacitor or shunt impedance at the input to the SAC. A switch in series with  $V_{IN}$  is added to the circuit. This is depicted in Figure 3.

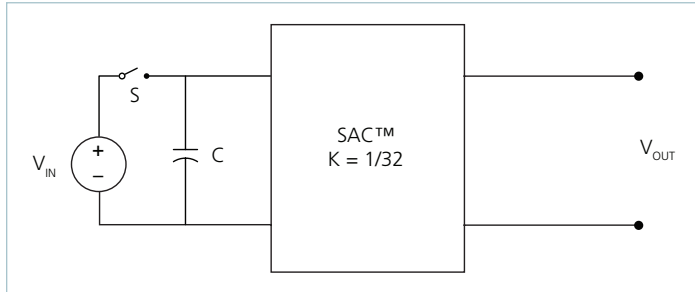

Figure 3 — Sine Amplitude Converter™ with input capacitor

A change in  $V_{IN}$  with the switch closed would result in a change in capacitor current according to the following equation:

$$I_C(t) = C \frac{dV_{IN}}{dt} \quad (7)$$

Assume that with the capacitor charged to  $V_{IN}$ , the switch is opened and the capacitor is discharged through the idealized SAC. In this case,

$$I_C = I_{OUT} \cdot K \quad (8)$$

Substituting Equations 1 and 8 into Equation 7 reveals:

$$I_{OUT} = \frac{C}{K^2} \cdot \frac{dV_{OUT}}{dt} \quad (9)$$

The equation in terms of the output has yielded a  $K^2$  scaling factor for C, specified in the denominator of the equation. A K factor less than unity results in an effectively larger capacitance on the output when expressed in terms of the input. With a  $K = 1/32$  as shown in Figure 3,  $C = 1\mu F$  would appear as  $C = 1024\mu F$  when viewed from the output.

Low impedance is a key requirement for powering a high-current, low-voltage load efficiently. A switching regulation stage should have minimal impedance while simultaneously providing appropriate filtering for any switched current. The use of a SAC between the regulation stage and the point-of-load provides a dual benefit of scaling down series impedance leading back to the source and scaling up shunt capacitance or energy storage as a function of its K factor squared. However, the benefits are not useful if the series impedance of the SAC is too high. The impedance of the SAC must be low, i.e., well beyond the crossover frequency of the system.

A solution for keeping the impedance of the SAC low involves switching at a high frequency. This enables small magnetic components because magnetizing currents remain low. Small magnetics mean small path lengths for turns. Use of low-loss core material at high frequencies also reduces core losses.

The two main terms of power loss in the VTM module are:

- No-Load Power Dissipation ( $P_{NL}$ ): defined as the power used to power up the module with an enabled powertrain at no load.
- Resistive loss ( $R_{OUT}$ ): refers to the power loss across the VTM modeled as pure resistive impedance.

$$P_{DISSIPATED} = P_{NL} + P_{ROUT} \quad (10)$$

Therefore,

$$P_{OUT} = P_{IN} - P_{DISSIPATED} = P_{IN} - P_{NL} - P_{ROUT} \quad (11)$$

The above relations can be combined to calculate the overall module efficiency:

$$\eta = \frac{P_{OUT}}{P_{IN}} = \frac{P_{IN} - P_{NL} - P_{ROUT}}{P_{IN}} \quad (12)$$

$$= \frac{V_{IN} \cdot I_{IN} - P_{NL} - (I_{OUT})^2 \cdot R_{OUT}}{V_{IN} \cdot I_{IN}}$$

$$= 1 - \left( \frac{P_{NL} + (I_{OUT})^2 \cdot R_{OUT}}{V_{IN} \cdot I_{IN}} \right)$$

## Input and Output Filter Design

A major advantage of a SAC system versus a conventional PWM converter is that the former does not require large functional filters. The resonant LC tank, operated at extreme high frequency, is amplitude modulated as a function of input voltage and output current and efficiently transfers charge through the isolation transformer. A small amount of capacitance embedded in the input and output stages of the module is sufficient for full functionality and is key to achieving high power density.

This paradigm shift requires system design to carefully evaluate external filters in order to:

- **Guarantee low source impedance:**

To take full advantage of the VTM module dynamic response, the impedance presented to its input terminals must be low from DC to approximately 5MHz. Input capacitance may be added to improve transient performance or compensate for high source impedance.

- **Further reduce input and/or output voltage ripple without sacrificing dynamic response:**

Given the wide bandwidth of the VTM module, the source response is generally the limiting factor in the overall system response. Anomalies in the response of the source will appear at the output of the VTM module multiplied by its K factor.

- **Protect the module from overvoltage transients imposed by the system that would exceed maximum ratings and cause failures:**

The VI Chip® module input/output voltage ranges must not be exceeded. An internal overvoltage lockout function prevents operation outside of the normal operating input range. Even during this condition, the powertrain is exposed to the applied voltage and power MOSFETs must withstand it.

## Capacitive Filtering Considerations for a Sine Amplitude Converter™

It is important to consider the impact of adding input and output capacitance to a Sine Amplitude Converter on the system as a whole. Both the capacitance value and the effective impedance of the capacitor must be considered.

A Sine Amplitude Converter has a DC  $R_{OUT}$  value which has already been discussed on Page 22. The AC  $R_{OUT}$  of the SAC contains several terms:

- Resonant tank impedance
- Input lead inductance and internal capacitance
- Output lead inductance and internal capacitance

The values of these terms are shown in the behavioral model on Page 22. It is important to note on which side of the transformer these impedances appear and how they reflect across the transformer given the K factor.

The overall AC impedance varies from model to model. For most models it is dominated by DC  $R_{OUT}$  value from DC to beyond 500kHz. The behavioral model on Page 22 should be used to approximate the AC impedance of the specific model.

Any capacitors placed at the output of the VTM module reflect back to the input of the module by the square of the K factor (Equation 9) with the impedance of the module appearing in series. It is very important to keep this in mind when using a PRM™ regulator to power the VTM module. Most PRM modules have a limit on the maximum amount of capacitance that can be applied to the output. This capacitance includes both the PRM output capacitance and the VTM module output capacitance reflected back to the input. In PRM module remote-sense applications, it is important to consider the reflected value of VTM module output capacitance when designing and compensating the PRM module control loop.

Capacitance placed at the input of the VTM module appear to the load reflected by the K factor with the impedance of the VTM module in series. In step-down ratios, the effective capacitance is increased by the K factor. The effective ESR of the capacitor is decreased by the square of the K factor, but the impedance of the module appears in series. Still, in most step-down VTM modules an electrolytic capacitor placed at the input of the module will have a lower effective impedance compared to an electrolytic capacitor placed at the output. This is important to consider when placing capacitors at the output of the module. Even though the capacitor may be placed at the output, the majority of the AC current will be sourced from the lower impedance, which in most cases will be the module. This should be studied carefully in any system design using a module. In most cases, it should be clear that electrolytic output capacitors are not necessary to design a stable, well-bypassed system.

## Current Sharing

The SAC™ topology bases its performance on efficient transfer of energy through a transformer without the need of closed-loop control. For this reason, the transfer characteristic can be approximated by an ideal transformer with some resistive drop and positive temperature coefficient.

This type of characteristic is close to the impedance characteristic of a DC power distribution system, both in behavior (AC dynamic) and absolute value (DC dynamic).

When connected in an array with the same K factor, the VTM module will inherently share the load current (typically 5%) with parallel units according to the equivalent impedance divider that the system implements from the power source to the point-of-load.

Some general recommendations to achieve matched array impedances:

- Dedicate common copper planes within the PCB to deliver and return the current to the modules.
- Provide the PCB layout as symmetric as possible.
- Apply same input / output filters (if present) to each unit.

For further details see:

[AN:016 Using BCM® Bus Converters in High Power Arrays.](#)

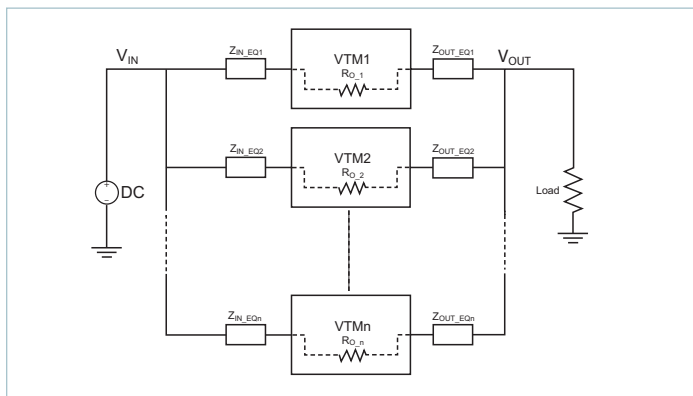

Figure 20 — VTM module array

## Fuse Selection

In order to provide flexibility in configuring power systems VI Chip® products are not internally fused. Input line fusing of VI Chip products is recommended at system level to provide thermal protection in case of catastrophic failure.

The fuse shall be selected by closely matching system requirements with the following characteristics:

- Current rating  
(usually greater than maximum current of VTM module)
- Maximum voltage rating  
(usually greater than the maximum possible input voltage)
- Ambient temperature
- Nominal melting  $I^2t$

## Reverse Operation

The MVTM is capable of reverse operation. If a voltage is present at the output which satisfies the condition  $V_{OUT} > V_{IN} \cdot K$  at the time the VC voltage is applied, or after the unit has started, then energy will be transferred from secondary to primary. The input-to-output ratio will be maintained. The MVTM will continue to operate in reverse as long as the input and output are within the specified limits. The MVTM has not been qualified for continuous operation (>10ms) in the reverse direction.

Product Outline & Recommended Land Pattern; Full VIC SMD, 18 pin

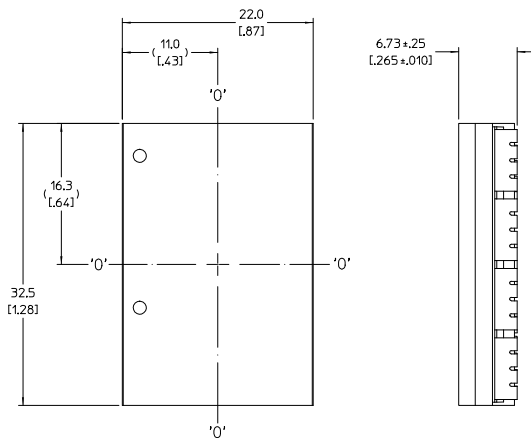

TOP VIEW (COMPONENT SIDE SHOWN)

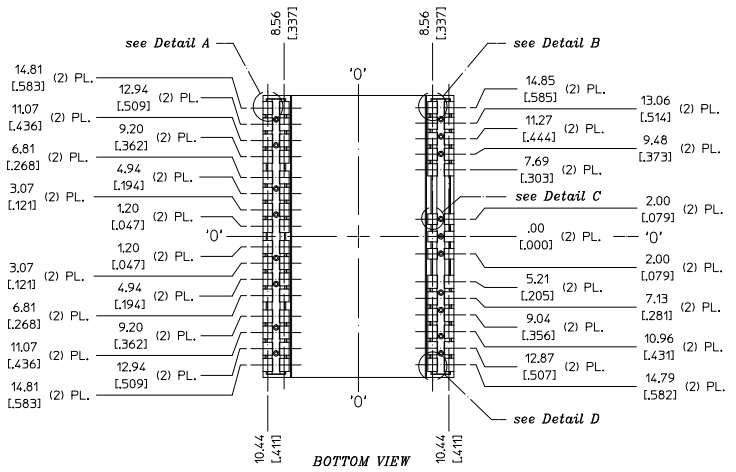

BOTTOM VIEW

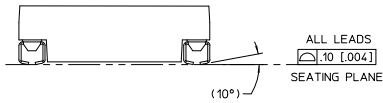

NOTE:

1. RoHS COMPLIANT PER CST-0001 LATEST REVISION.

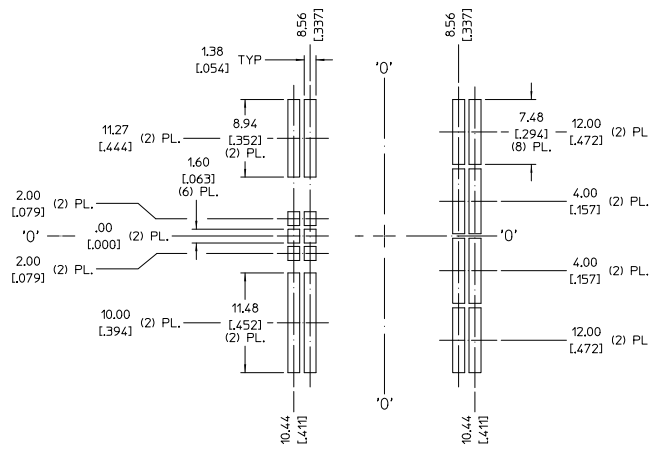
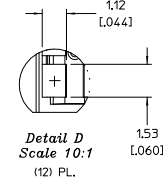
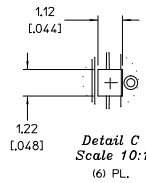
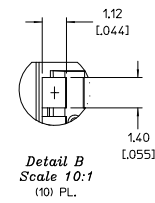
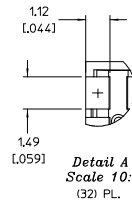

RECOMMENDED LAND PATTERN  
(COMPONENT SIDE SHOWN)

Product Outline & Recommended Land Pattern; Full VIC TH, 60 pin

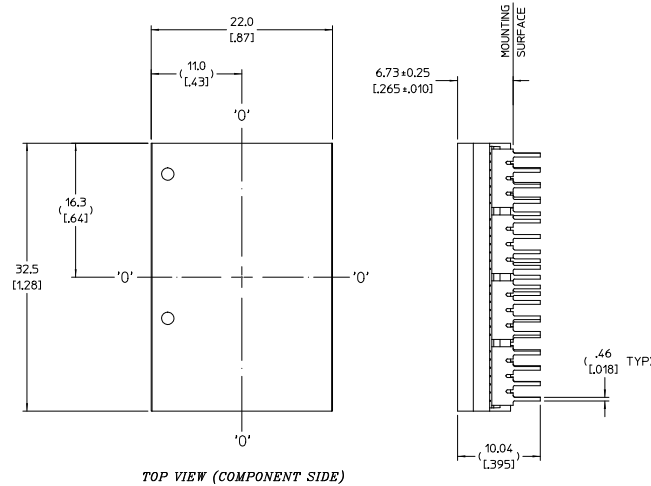

TOP VIEW (COMPONENT SIDE)

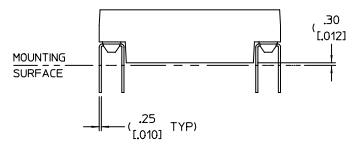

NOTE:

1. RoHS COMPLIANT PER CST-0001 LATEST REVISION.

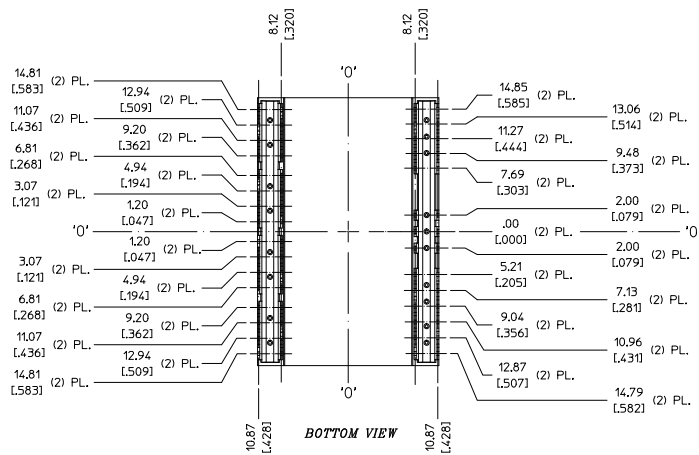

BOTTOM VIEW

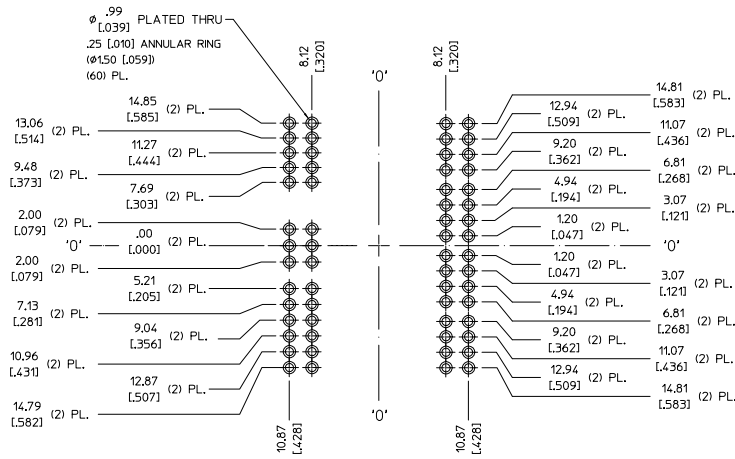

RECOMMENDED LAND PATTERN  
(COMPONENT SIDE SHOWN)

Recommended Heat Sink Push Pin Location; Full

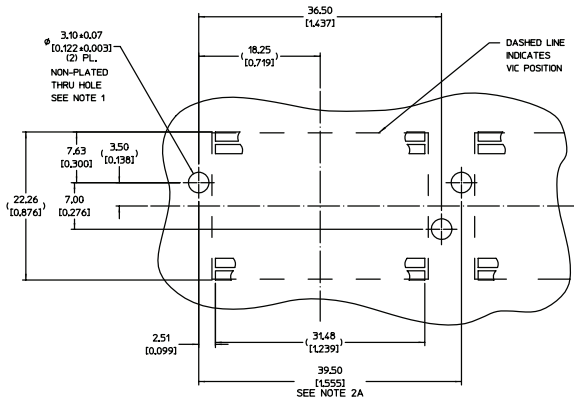

(NO GROUNDING CLIPS)

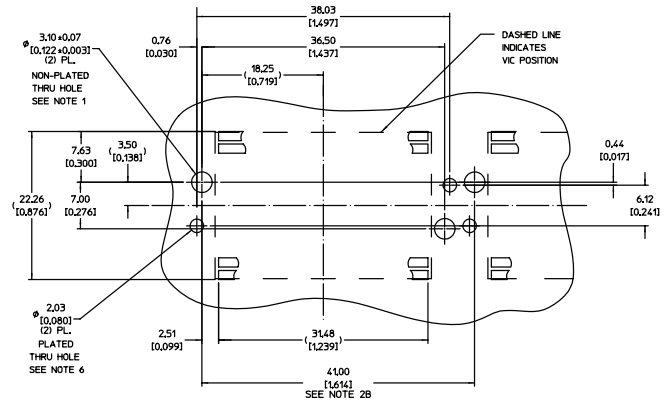

(WITH GROUNDING CLIPS)

Notes:

- Maintain 3.50 (0.138) Dia. keep-out zone free of copper, all PCB layers.
- (A) Minimum recommended pitch is 39.50 (1.555). This provides 7.00 (0.275) component edge-to-edge spacing, and 0.50 (0.020) clearance between Vicor heat sinks.  
(B) Minimum recommended pitch is 41.00 (1.614). This provides 8.50 (0.334) component edge-to-edge spacing, and 2.00 (0.079) clearance between Vicor heat sinks.
- VI Chip® module land pattern shown for reference only; actual land pattern may differ. Dimensions from edges of land pattern to push-pin holes will be the same for all full-size VI Chip® products.
- RoHS compliant per CST-0001 latest revision.
- Unless otherwise specified: Dimensions are mm (inches) tolerances are:  
x.x (x.xx) = ±0.3 (0.01)  
x.xx (x.xxx) = ±0.13 (0.005)
- Plated through holes for grounding clips (33855) shown for reference, heat sink orientation and device pitch will dictate final grounding solution.

Mechanical Drawing; Half VIC SMT, 12 pin

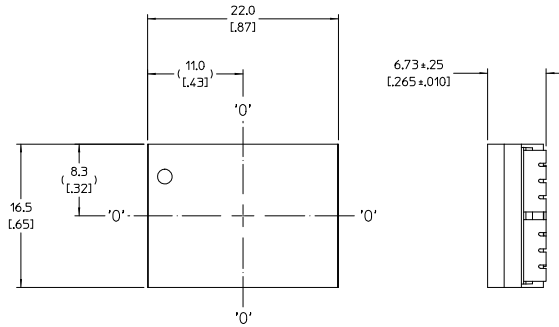

TOP VIEW (COMPONENT SIDE)

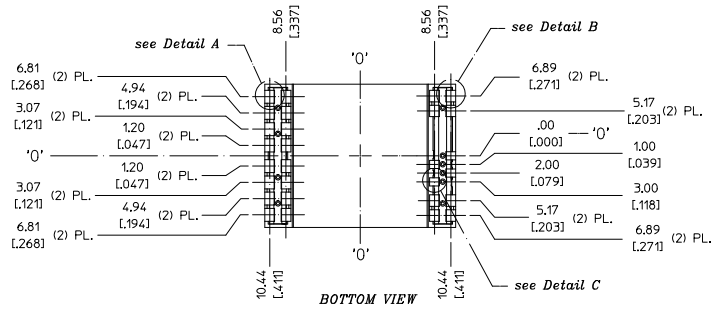

BOTTOM VIEW

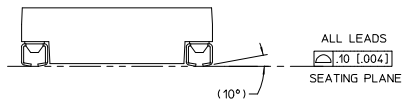

NOTE:

1. RoHS COMPLIANT PER CST-0001 LATEST REVISION.

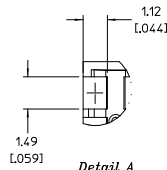

Detail A  
Scale 10:1  
(16) PL.

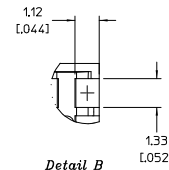

Detail B  
Scale 10:1  
(8) PL.

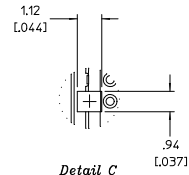

Detail C  
Scale 10:1  
(4) PL.

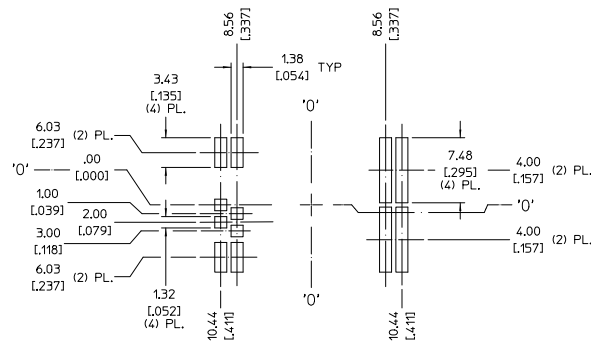

RECOMMENDED LAND PATTERN  
(COMPONENT SIDE SHOWN)

Recommended Heat Sink Push Pin Location; Half

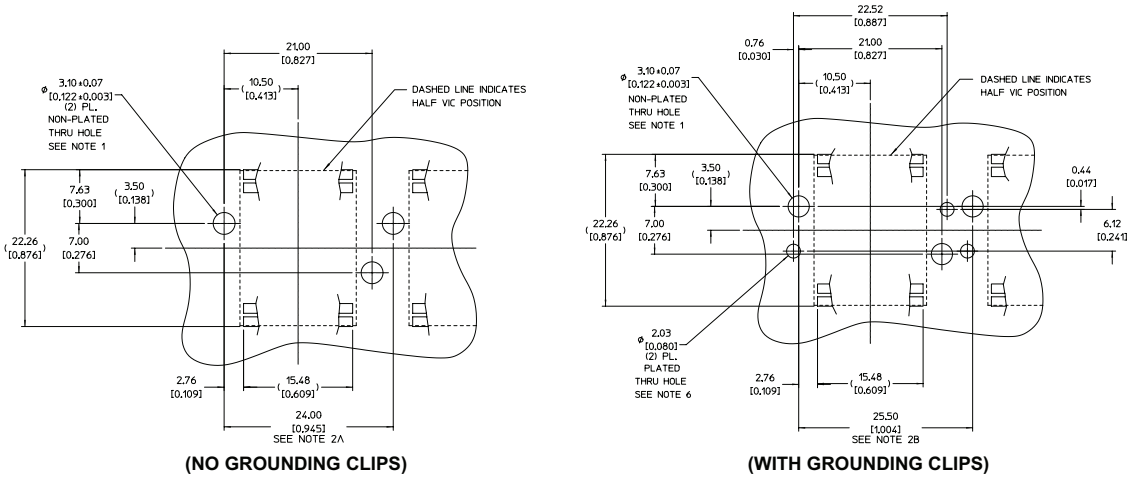

Notes:

1. Maintain 3.50 (0.138) Dia. keep-out zone free of copper, all PCB layers.

2. (A) minimum recommended pitch is 24.00 (0.945) this provides 7.50 (0.295) component edge-to-edge spacing, and 0.50 (0.020) clearance between Vicor heat sinks.

(B) Minimum recommended pitch is 25.50 (1.004). This provides 9.00 (0.354) component edge-to-edge spacing, and 2.00 (0.079) clearance between Vicor heat sinks.

3. VI Chip® module land pattern shown for reference only, actual land pattern may differ. Dimensions from edges of land pattern to push-pin holes will be the same for all half size V-I Chip Products.

4. RoHS compliant per CST-0001 latest revision.

5. Unless otherwise specified:

Dimensions are mm (inches) tolerances are:

x.x (x.xx) = ±0.13 (0.01)

x.xx (x.xxx) = ±0.13 (0.005)

6. Plated through holes for grounding clips (33855) shown for reference. Heat sink orientation and device pitch will dictate final grounding solution.

## Revision History

Revision	Date	Description	Page Number(s)
1.0	03/2014	Initial release	n/a
1.1	11/25/14	Typ value of VC internal resistor	12
1.2	01/07/15	Updated 3V part to B version	5
1.3	07/17/15	MSL changes	19 & 20
1.4	10/23/20	Revised ambient and hot output resistance specs for MVTM36BF360M003A00	12
1.5	01/12/22	Document format update Revised output resistance specification for MVTM36BF360M003A00 Revised VC current draw, inrush current specs, $t_{ON}$ conditions/notes	All 12 16

**Vicor's comprehensive line of power solutions includes high density AC-DC and DC-DC modules and accessory components, fully configurable AC-DC and DC-DC power supplies, and complete custom power systems.**

Information furnished by Vicor is believed to be accurate and reliable. However, no responsibility is assumed by Vicor for its use. Vicor makes no representations or warranties with respect to the accuracy or completeness of the contents of this publication. Vicor reserves the right to make changes to any products, specifications, and product descriptions at any time without notice. Information published by Vicor has been checked and is believed to be accurate at the time it was printed; however, Vicor assumes no responsibility for inaccuracies. Testing and other quality controls are used to the extent Vicor deems necessary to support Vicor's product warranty. Except where mandated by government requirements, testing of all parameters of each product is not necessarily performed.

**Specifications are subject to change without notice.**

Visit [https://www.vicorpower.com/mil-cots\\_dc-dc/mil-cots\\_prm\\_regulator\\_and\\_vtm\\_current\\_multiplier](https://www.vicorpower.com/mil-cots_dc-dc/mil-cots_prm_regulator_and_vtm_current_multiplier) for the latest product information.

**Vicor's Standard Terms and Conditions and Product Warranty**

All sales are subject to Vicor's Standard Terms and Conditions of Sale, and Product Warranty which are available on Vicor's webpage (<http://www.vicorpower.com/termsconditionswarranty>) or upon request.

**Life Support Policy**

VICOR'S PRODUCTS ARE NOT AUTHORIZED FOR USE AS CRITICAL COMPONENTS IN LIFE SUPPORT DEVICES OR SYSTEMS WITHOUT THE EXPRESS PRIOR WRITTEN APPROVAL OF THE CHIEF EXECUTIVE OFFICER AND GENERAL COUNSEL OF VICOR CORPORATION. As used herein, life support devices or systems are devices which (a) are intended for surgical implant into the body, or (b) support or sustain life and whose failure to perform when properly used in accordance with instructions for use provided in the labeling can be reasonably expected to result in a significant injury to the user. A critical component is any component in a life support device or system whose failure to perform can be reasonably expected to cause the failure of the life support device or system or to affect its safety or effectiveness. Per Vicor Terms and Conditions of Sale, the user of Vicor products and components in life support applications assumes all risks of such use and indemnifies Vicor against all liability and damages.

**Intellectual Property Notice**

Vicor and its subsidiaries own Intellectual Property (including issued U.S. and Foreign Patents and pending patent applications) relating to the products described in this data sheet. No license, whether express, implied, or arising by estoppel or otherwise, to any intellectual property rights is granted by this document. Interested parties should contact Vicor's Intellectual Property Department.

The products described on this data sheet are protected by the following U.S. Patents Numbers:

5,945,130; 6,403,009; 6,710,257; 6,911,848; 6,930,893; 6,934,166; 6,940,013; 6,969,909; 7,038,917; 7,145,786; 7,166,898; 7,187,263; 7,202,646; 7,361,844; D496,906; D505,114; D506,438; D509,472; and for use under 6,975,098 and 6,984,965.

Contact Us: <http://www.vicorpower.com/contact-us>

**Vicor Corporation**  
25 Frontage Road  
Andover, MA, USA 01810  
Tel: 800-735-6200  
Fax: 978-475-6715  
[www.vicorpower.com](http://www.vicorpower.com)

**email**

Customer Service: [custserv@vicorpower.com](mailto:custserv@vicorpower.com)  
Technical Support: [apps@vicorpower.com](mailto:apps@vicorpower.com)

## Looking for pricing, stock, or lifecycle information?

Click below to explore more details on WIN SOURCE:

 [View MVTM36BF240M005A00 on WIN SOURCE](#)

 [Vicor Corporation](#) Information

## Optimize Your Supply Chain with WIN SOURCE Solutions

-  Global Sourcing Solution
-  Obsolete Management
-  Cost Control Management
-  Shortage Management
-  Alternative Solution
-  Excess Inventory Management