



**THE DATASHEET OF  
TPT71044-SOBR**



## Features

- Meet ISO11898 Standard
- Support CAN FD and Data Rates up to 5 Mbps
- Typical Loop Delay: 110 ns
- 5-V Power Supply, 2.25-V to 5.5-V IO Interface
- Receiver Common-Mode Input Voltage:  $\pm 30$  V
- Bus Fault Protection:  $\pm 42$  V
- Up to 5-kV RMS Isolation Rating (WSOP)
- $\pm 200$ -kV/ $\mu$ s typ Static CMTI,  $\pm 150$ -kV/ $\mu$ s typ Dynamic CMTI
- Junction Temperatures from  $-40^{\circ}\text{C}$  to  $150^{\circ}\text{C}$
- SMP8 and Wide-SOP (WSOP8, WSOP16)
- BUS pin ESD Protection (between Bus pins and GNDB)
  - $\pm 15$ -kV IEC 61000-4-2 Contact Discharge
- Safety-Related Certifications:
  - VDE Certification according to DIN VDE V 0884-17 (IEC60747-17)
  - 5000-VRMS (WSOP16, WSOP8), 3750-VRMS (SMP8) Isolation Rating per UL 1577
  - CQC Certification per GB 4943.1
  - CSA, TUV, and CB Certifications

## Applications

- Industrial Automation
- Motor Control
- Solar Inverters
- Battery Charging and Management

## Description

The TPT710xx device is an isolated CAN transceiver that meets the ISO11898 High-speed CAN (Controller Area Network) physical layer standard. The device is designed to be applied in CAN FD networks up to 5 Mbps and to enhance timing margin and higher data rates in long and high-loading networks. As the design, the device features cross-wire, overvoltage, and loss of ground protection from  $-42$  V to  $+42$  V, overtemperature shutdown, and a  $-30$  V to  $+30$  V common-mode range. The VCCA is the power supply input for RXD and TXD I/O pins which support a wide range from 2.25 V to 5.5 V. The 2<sup>nd</sup> power supply VCCB of CAN BUS side which supports the range from 4.5 V to 5.5 V.

The devices integrate high-performance digital isolators with 5000 VRMS (WSOP8, WSOP16 packages), 3750 VRMS (SMP8 package), and isolation ratings per UL 1577. These devices are also to be certified by VDE, UL, CSA, and CQC.

TPT710xx family is available in WSOP8, WSOP16, and SMP8 packages, and is characterized from  $-40^{\circ}\text{C}$  to  $+125^{\circ}\text{C}$ .

## Functional Block Diagram

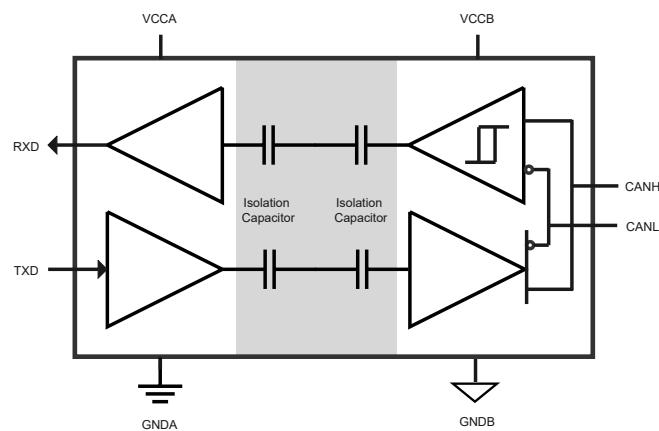

## Table of Contents

<b>Features</b> .....	<b>1</b>
<b>Applications</b> .....	<b>1</b>
<b>Description</b> .....	<b>1</b>
<b>Functional Block Diagram</b> .....	<b>1</b>
<b>Revision History</b> .....	<b>3</b>
<b>Pin Configuration and Functions</b> .....	<b>4</b>
<b>Specifications</b> .....	<b>6</b>
Absolute Maximum Ratings <sup>(1)</sup> .....	6
ESD, Electrostatic Discharge Protection.....	6
Recommended Operating Conditions.....	6
Thermal Information.....	7
Insulation Specifications.....	7
Safety-Related Certifications.....	9
Safety Limiting Values.....	11
Electrical Characteristics.....	12
Electrical Characteristics - DC Specification.....	14
Switching Characteristics.....	16
Test Circuits and Waveforms.....	18
<b>Detailed Description</b> .....	<b>21</b>
Overview.....	21
Functional Block Diagram.....	21
Feature Description.....	22
<b>Application and Implementation</b> .....	<b>24</b>
Application Information.....	24
Typical Application.....	24
<b>Tape and Reel Information</b> .....	<b>25</b>
<b>Package Outline Dimensions</b> .....	<b>26</b>
WSOP8-B.....	26
WSOP16.....	27
SMP-8.....	28
<b>Order Information</b> .....	<b>29</b>
<b>IMPORTANT NOTICE AND DISCLAIMER</b> .....	<b>30</b>

## Revision History

<b>Date</b>	<b>Revision</b>	<b>Notes</b>
2022-02-07	Rev.Pre.0	Preliminary version.
2022-11-01	Rev.A.0	Released version.
2022-12-21	Rev.A.1	Updated Order Information.
2022-12-27	Rev.A.2	Updated EC table.

## Pin Configuration and Functions

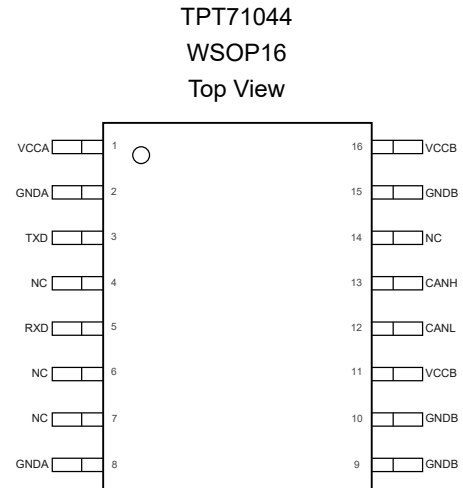
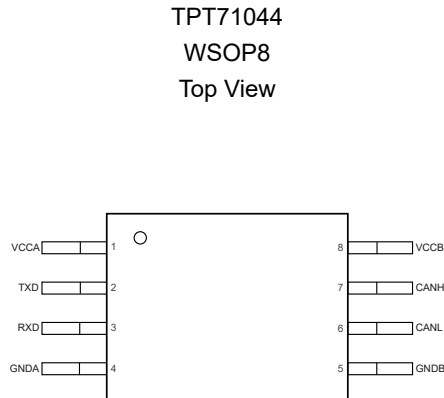
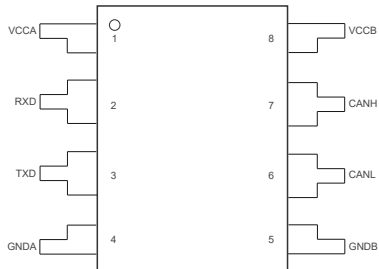

**Table 1. Pin Functions: TPT71044**

Pin No.		Pin Name	I/O	Description
WSOP8	WSOP16			
TPT7104x	TPT7104x			
1	1	VCCA	-	Power supply, VCCA
2	3	TXD	I	Input, CAN transmit data in
3	5	RXD	O	Output, CAN receive data out
4	2, 8	GNDA	-	Ground connection for VCCA
5	9, 10, 15	GNDB	-	Ground connection for VCCB
6	12	CANL	IO	Low level CAN bus input/output line
7	13	CANH	IO	High level CAN bus input/output line
8	11, 16	VCCB	-	Power supply, VCCB
-	4, 6, 7, 14	NC	-	No Connect

**Isolated CAN Transceiver with Flexible Data Rate**

TPT71050  
SMP8  
Top View



TPT71050  
WSOP16  
Top View

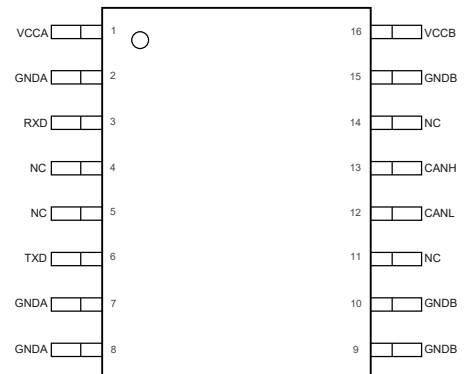

**Table 2. Pin Functions: TPT71050**

Pin No.		Pin Name	I/O	Description
WSOP8	WSOP16			
TPT71050	TPT71050			
1	1	VCCA	-	Power supply, VCCA
2	3	RXD	O	Output, CAN receive data out
3	5	TXD	I	Input, CAN transmit data in
4	2, 8	GNDA	-	Ground connection for VCCA
5	9, 10, 15	GNDB	-	Ground connection for VCCB
6	12	CANL	IO	Low level CAN bus input/output line
7	13	CANH	IO	High level CAN bus input/output line
8	16	VCCB	-	Power supply, VCCB
-	4, 6, 7, 11, 14	NC	-	No Connect

## Specifications

### Absolute Maximum Ratings <sup>(1)</sup>

Parameter		Min	Max	Unit
V <sub>CC</sub>	Supply Voltage, V <sub>CCA</sub> , V <sub>CCB</sub> <sup>(2)</sup>	-0.5	6	V
I <sub>O</sub>	Output Current	-15	15	mA
T <sub>J</sub>	Operating Virtual Junction Temperature	-	150	°C
T <sub>stg</sub>	Storage Temperature	-65	150	°C

(1) Stresses beyond those listed under Absolute Maximum Ratings may cause permanent damage to the device. Exposure to any Absolute Maximum Rating condition for extended periods may affect device reliability and lifetime.

(2) This data was taken with the JEDEC low effective thermal conductivity test board.

(3) This data was taken with the JEDEC standard multilayer test boards.

### ESD, Electrostatic Discharge Protection

Parameter		Condition	Minimum Level	Unit
IEC	IEC-61000-4-2, Contact Discharge	Bus pin to GNDB	±15	kV
	IEC-61000-4-2, Air-Gap Discharge	Bus pin to GNDB	±15	kV
HBM	HBM, per ANSI/ESDA/JEDEC JS-001 <sup>(1)</sup>	Bus pin to GNDB	±15	kV
		All pins except bus Pin	±6	kV
CDM	CDM, per ANSI/ESDA/JEDEC JS-002 <sup>(2)</sup>	All pins	±1.5	kV
LU	Latch up, per JESD78	All pins	±600	mA

(1) JEDEC document JEP155 states that 500-V HBM allows safe manufacturing with a standard ESD control process.

(2) JEDEC document JEP157 states that 250-V CDM allows safe manufacturing with a standard ESD control process.

### Recommended Operating Conditions

Parameter		Min	Typ	Max	Unit
V <sub>CCB</sub>	Supply Voltage, V <sub>CCB</sub>	4.5		5.5	V
V <sub>CCA</sub>	Supply Voltage, V <sub>CCA</sub>	2.25		5.5	V
V <sub>IH</sub>	High-level Input Voltage (data input)	2		V <sub>CC</sub>	V
V <sub>IL</sub>	Low-level Input Voltage (data input)	0		0.8	V
f <sub>data</sub>	Data Rate <sup>(1)</sup>	0		5	Mbps
T <sub>A</sub>	Operating Ambient Temperature	-40	25	125	°C

(1) 5 Mbps is the maximum specified data rate, although higher data rates are possible.

**Isolated CAN Transceiver with Flexible Data Rate**
**Thermal Information**

Package Type	$\theta_{JA}$	$\theta_{JC}$	Unit
WSOP8	85	43	°C/W
WSOP16	75	41	°C/W
SMP8	74	65	°C/W

**Insulation Specifications**

Parameter		Conditions	Value			Unit
			SMP8	WSOP8	WSOP16	
CLR	External clearance	Shortest terminal-to-terminal distance through air	> 6.5	> 8.0	> 8.0	mm
CPG	External creepage	Shortest terminal-to-terminal distance across the package surface	> 6.5	> 8.0	> 8.0	mm
DTI	Distance through the insulation	Minimum internal gap (internal clearance)	> 22	> 22	> 22	μm
DTC	Distance through the Molding compound	Minimum internal distance across the conductors inside the package	0.45	0.8	0.8	mm
CTI	Comparative tracking index		> 600	> 600	> 600	V
	Material group		I	I	I	
	Over-voltage category	For Rated Mains Voltage ≤ 150 V <sub>RMS</sub>	I-IV	I-IV	I-IV	
		For Rated Mains Voltage ≤ 300 V <sub>RMS</sub>	I-III	I-IV	I-IV	
		For Rated Mains Voltage ≤ 600 V <sub>RMS</sub>	I-II	I-IV	I-IV	
		For Rated Mains Voltage ≤ 1000 V <sub>RMS</sub>	I	I-III	I-III	
	Climatic category		40/125/21	40/125/21	40/125/21	
	Pollution degree		2	2	2	
<b>DIN V VDE V 0884-17 (1)(2)</b>						
V <sub>IORM</sub>	Maximum repetitive isolation voltage	AC voltage	637	1414	1414	V <sub>PK</sub>
V <sub>IOWM</sub>	Maximum working isolation voltage	AC voltage; TDDb Test	450	1000	1000	V <sub>RMS</sub>
		DC voltage	637	1414	1414	V <sub>DC</sub>
V <sub>IOTM</sub>	Maximum transient isolation voltage	V <sub>TEST</sub> = V <sub>IOTM</sub> , t = 60 s (qualification); V <sub>TEST</sub> = 1.2 × V <sub>IOTM</sub> , t = 1 s (100% production)	5300	7070	7070	V <sub>PK</sub>
V <sub>IOSM</sub>	Maximum surge isolation voltage <sup>(3)</sup>	Test method per IEC 62368-1, 1.2/50 μs waveform, V <sub>TEST</sub> = 1.3 × V <sub>IOSM</sub> (qualification)	5980	6500	6500	V <sub>PK</sub>

**Isolated CAN Transceiver with Flexible Data Rate**

Parameter		Conditions	Value			Unit
			SMP8	WSOP8	WSOP16	
Q <sub>pd</sub>	Apparent charge	Method a, After Input/Output safety test subgroup 2/3, V <sub>ini</sub> = V <sub>IOTM</sub> , t <sub>ini</sub> = 60 s; V <sub>pd(m)</sub> = 1.2 × V <sub>IORM</sub> , t <sub>m</sub> = 10 s	≤ 5	≤ 5	≤ 5	pC
		Method a, After environmental tests subgroup 1, V <sub>ini</sub> = V <sub>IOTM</sub> , t <sub>ini</sub> = 60 s; V <sub>pd(m)</sub> = 1.6 × V <sub>IORM</sub> , t <sub>m</sub> = 10 s	≤ 5	≤ 5	≤ 5	
		Method b1; At routine test (100% production) and preconditioning (type test), V <sub>ini</sub> = 1.2 × V <sub>IOTM</sub> , t <sub>ini</sub> = 1 s; V <sub>pd(m)</sub> = 1.875 × V <sub>IORM</sub> , t <sub>m</sub> = 1 s	≤ 5	≤ 5	≤ 5	
C <sub>IO</sub>	Isolation capacitance	V <sub>IO</sub> = 0.4 × sin (2πft), f = 1 MHz	~0.5	~0.5	~0.5	pF
R <sub>IO</sub>	Isolation resistance	V <sub>IO</sub> = 500 V, T A= 25°C	> 10 <sup>12</sup>	> 10 <sup>12</sup>	> 10 <sup>12</sup>	Ω
		V <sub>IO</sub> = 500 V, 100°C ≤ T A≤ 125°C	> 10 <sup>11</sup>	> 10 <sup>11</sup>	> 10 <sup>11</sup>	Ω
		V <sub>IO</sub> = 500 V at T S= 150°C	> 10 <sup>9</sup>	> 10 <sup>9</sup>	> 10 <sup>9</sup>	Ω
<b>UL 1577</b>						
V <sub>ISO</sub>	Withstanding isolation voltage	V <sub>TEST</sub> = V <sub>ISO</sub> , t = 60 s(qualification); V <sub>TEST</sub> = 1.2 × V <sub>ISO</sub> , t = 1 s (100% production)	3750	5000	5000	V <sub>RMS</sub>

- (1) All pins on each side of the barrier are tied together creating a two-terminal device.
- (2) This coupler is suitable for safe electrical insulation only within the safety operating ratings. Compliance with the safety ratings shall be ensured by means of suitable protective circuits.
- (3) Testing must be carried out in oil.

**Isolated CAN Transceiver with Flexible Data Rate**
**Safety-Related Certifications**

VDE	UL	TUV	CQC	CSA	CB
Certified according to DIN EN IEC 60747-17 (VDE 0884-17)	Certified according to UL 1577 and CSA Component Acceptance Service No. 5A	Certified according to EN IEC 62368-1 and EN IEC 61010-1	Certified according to GB 4943.1	Certified CSA C22.2 No. 62368-1 and CAN/CSA-C22.2 No. 60601-1	Certified according to EN IEC 62368-1
Basic insulation (WSOP) VIORM = 1414 VIO SM = 6500 (SOP, QSOP) VIORM = 637 VIO SM = 5980	(WSOP) Single protection, 5000 Vrms (SOP, QSOP) Single protection, 3750 Vrms	6400 Vrms reinforced insulation (WSOP), 800 Vrms maximum work voltage. 4000 Vrms basic insulation (SOP, QSOP), 400 V rms maximum work voltage.	Reinforced insulation (WSOP), Altitude ≤ 5000m, 800-V rms maximum work voltage. Basic insulation (SOP, QSOP), Altitude ≤ 5000m, 400-V rms maximum work voltage.	400-Vrms basic insulation (SOP, QSOP) and 600-V rms reinforced insulation (WSOP) working voltage per CSA C22.2 No. 62368-1:19 3rd, IEC 62368-1:2018 Ed. 3 (in pollution degree 2, material group I) 2 MOPP (Means of Patient Protection) insulation requirements for 250Vrms and 1 MOPP insulation requirements for 500Vrms (WSOP) in CAN/CSA-C22.2 No. 60601-1:14, IEC 60601-1:2005 + AMD1:2012. 1 MOPP (Means of Patient Protection) insulation requirements for 250Vrms (SOP, QSOP) in CAN/CSA-C22.2 No. 60601-1:14, IEC 60601-1:2005 + AMD1:2012	Reinforced insulation (WSOP), Altitude ≤ 5000m, 800-V rms maximum work voltage. Basic insulation (SOP, QSOP), Altitude ≤ 5000m, 400-V rms maximum work voltage
Certificate No. 40054570	Report Reference E524241	AK 50560071 0001	Certificate No. CQC22001356658	Master contract: 302375	Ref. Certif. No. CN57658

---

Isolated CAN Transceiver with Flexible Data Rate

VDE	UL	TUV	CQC	CSA	CB
		AK 50560072 0001			

**Isolated CAN Transceiver with Flexible Data Rate**
**Safety Limiting Values**

Parameter	Conditions <sup>(1)</sup>	Min	Typ	Max	Unit
Safety Supply Current	$R_{\theta JA} = 74^{\circ}\text{C/W}$ , $V_I = 5\text{ V}$ , $T_J = 150^{\circ}\text{C}$ , $T_A = 25^{\circ}\text{C}$ (SMP8)			337.8	mA
	$R_{\theta JA} = 85^{\circ}\text{C/W}$ , $V_I = 5\text{ V}$ , $T_J = 150^{\circ}\text{C}$ , $T_A = 25^{\circ}\text{C}$ (WSOP8)			294.1	
	$R_{\theta JA} = 75^{\circ}\text{C/W}$ , $V_I = 5\text{ V}$ , $T_J = 150^{\circ}\text{C}$ , $T_A = 25^{\circ}\text{C}$ (WSOP16)			333.3	
Safety Total Power	$R_{\theta JA} = 74^{\circ}\text{C/W}$ , $T_J = 150^{\circ}\text{C}$ , $T_A = 25^{\circ}\text{C}$ (SMP8)			1689.1	mW
	$R_{\theta JA} = 85^{\circ}\text{C/W}$ , $T_J = 150^{\circ}\text{C}$ , $T_A = 25^{\circ}\text{C}$ (WSOP8)			1470.5	
	$R_{\theta JA} = 75^{\circ}\text{C/W}$ , $T_J = 150^{\circ}\text{C}$ , $T_A = 25^{\circ}\text{C}$ (WSOP16)			1666.6	
Maximum Safety Temperature				150	$^{\circ}\text{C}$

(1) The assumed junction-to-air thermal resistance in the Thermal Information is that of a device installed on a high-K test board for leaded surface-mount packages.

**Isolated CAN Transceiver with Flexible Data Rate**
**Electrical Characteristics**

All test conditions:  $V_{CCA} = 2.25\text{ V} \sim 5.5\text{ V}$ ,  $V_{CCB} = 4.5\text{ V} \sim 5.5\text{ V}$ ,  $T_A = -40^\circ\text{C}$  to  $125^\circ\text{C}$ . Typical value is in  $V_{CCA} = 3.3\text{ V}$ ,  $V_{CCB} = 5\text{ V}$ ,  $T_A = +25^\circ\text{C}$ ., unless otherwise noted.

Parameter	Test Conditions	Min	Typ	Max	Unit	
<b>Power Supply</b>						
$I_{CCA}$	Supply Current Side A	Bus dominant, $V_{CCA} = 2.25\text{ V}$ to $5.5\text{ V}$ , $TXD = 0\text{ V}$		2.3	8	mA
		Bus recessive, $V_{CCA} = 2.25\text{ V}$ to $5.5\text{ V}$ , $TXD = V_{CCA}$		1.3	4.1	mA
		$V_{CCA} = 4.5$ to $5.5\text{ V}$ , $TXD = 1\text{ Mbps}$ 50% duty square wave		2.0	7.6	mA
		$V_{CCA} = 4.5$ to $5.5\text{ V}$ , $TXD = 5\text{ Mbps}$ 50% duty square wave		2.0	9	mA
$I_{CCB}$	Supply Current Side B	Bus dominant, $TXD = 0\text{ V}$ , $R_L = 60\ \Omega$		10	80	mA
		Bus recessive, $TXD = V_{CCA}$ , $R_L = 60\ \Omega$		1	6	mA
		$V_{CCB} = 4.5$ to $5.5\text{ V}$ , $TXD = 1\text{ Mbps}$ 50% duty square wave		10	50	mA
		$V_{CCB} = 4.5$ to $5.5\text{ V}$ , $TXD = 5\text{ Mbps}$ 50% duty square wave		10	60	mA
$UV_{VCCA}$	Rising under Voltage Detection, Side A		2	2.2	V	
$UV_{VCCA}$	Falling under Voltage Detection, Side A	1.7	1.85		V	
$V_{HYS(UVCCA)}$	Hysteresis Voltage on $V_{CCA}$ Undervoltage Lock-out <sup>(1)</sup>		150		mV	
$UV_{VCCB}$	Rising under Voltage Detection, side B		4.2	4.4	V	
$UV_{VCCB}$	Falling under Voltage Detection, side B	3.5	4.0		V	
$V_{HYS(UVCCB)}$	Hysteresis Voltage on $V_{CCB}$ Undervoltage Lock-out <sup>(1)</sup>		200		mV	
<b>TXD Terminal</b>						
$V_{IH}$	High Level Input Voltage		2		V <sub>CC</sub>	V
$V_{IL}$	Low Level Input Voltage		0		0.8	V
$I_{IH}$	High Level Input Leakage Current	$TXD = V_{CCA}$			5	uA
$I_{IL}$	Low Level Input Leakage Current	$TXD = 0\text{ V}$	-20			uA

**Isolated CAN Transceiver with Flexible Data Rate**

Parameter		Test Conditions	Min	Typ	Max	Unit
$C_i$	Input Capacitance <sup>(1)</sup>	$V_{IN} = 0.4 \times \sin(2 \times \pi \times 1E+6 \times t) + 2.5 \text{ V}$ , $V_{CCA} = 5 \text{ V}$		5		pF
$V_{OH} - V_{CCA}$	High Level Output Voltage	$I_o = -4 \text{ mA}$ for $4.5 \text{ V} \leq V_{CCA} \leq 5.5 \text{ V}$	-0.4			V
		$I_o = -2 \text{ mA}$ for $3.0 \text{ V} \leq V_{CCA} \leq 3.6 \text{ V}$	-0.2			V
		$I_o = -1 \text{ mA}$ for $2.25 \text{ V} \leq V_{CCA} \leq 2.75 \text{ V}$	-0.1			V
$V_{OL}$	Low Level Output Voltage	$I_o = 4 \text{ mA}$ for $4.5 \text{ V} \leq V_{CCA} \leq 5.5 \text{ V}$			0.4	V
		$I_o = 2 \text{ mA}$ for $3.0 \text{ V} \leq V_{CCA} \leq 3.6 \text{ V}$			0.2	V
		$I_o = 1 \text{ mA}$ for $2.25 \text{ V} \leq V_{CCA} \leq 2.75 \text{ V}$			0.1	V
<b>Driver Electrical Characteristics</b>						
$V_{O(DOM)}$	Bus Output Voltage (Dominant), CANH	TXD = 0 V, $50 \Omega \leq R_L \leq 65 \Omega$ , $C_L = \text{open}$	2.75		4.5	V
	Bus Output Voltage (Dominant), CANL	TXD = 0 V, $50 \Omega \leq R_L \leq 65 \Omega$ , $C_L = \text{open}$	0.5		2.25	V
$V_{O(REC)}$	Bus Output Voltage (recessive), CANH and CANL	TXD = $V_{CCA}$ , $R_L = \text{open}$	2.0	$0.5 \times V_{CCB}$	3.0	V

(1) Provided by bench test and design simulation

**Isolated CAN Transceiver with Flexible Data Rate**
**Electrical Characteristics - DC Specification**

All test conditions:  $V_{CCA} = 2.25\text{ V} \sim 5.5\text{ V}$ ,  $V_{CCB} = 4.5\text{ V} \sim 5.5\text{ V}$ ,  $T_A = -40^\circ\text{C}$  to  $125^\circ\text{C}$ . Typical value is in  $V_{CCA} = 3.3\text{ V}$ ,  $V_{CCB} = 5\text{ V}$ ,  $T_A = +25^\circ\text{C}$ , unless otherwise noted.

Parameter	Test Conditions	Min	Typ	Max	Unit	
<b>Power Supply</b>						
$V_{OD(DOM)}$	Differential Output Voltage, CANH – CANL (dominant)	TXD = 0 V, $45\ \Omega \leq R_L \leq 50\ \Omega$ , $C_L = \text{open}$	1.4		3.0	V
		TXD = 0 V, $50\ \Omega \leq R_L \leq 65\ \Omega$ , $C_L = \text{open}$	1.5		3.0	V
		TXD = 0 V, $R_L = 2240\ \Omega$ , $C_L = \text{open}$ , $V_{CCB} = 4.5\text{ V} \sim 5.25\text{ V}$	1.5		5.0	V
$V_{OD(REC)}$	Differential Output Voltage, CANH-CANL (recessive)	TXD = $V_{CCA}$ , $R_L = 60\ \Omega$ , $C_L = \text{open}$	-120		30	mV
		TXD = $V_{CCA}$ , $R_L = \text{open}$ , $C_L = \text{open}$	-50		50	mV
$V_{SYM\_DC}$	DC Output Symmetry ( $V_{CCB} - V_{O(CANH)} - V_{O(CANL)}$ )	$R_L = 60\ \Omega$ , $C_L = \text{open}$ , TXD = $V_{CCA}$ or 0 V	-400		400	mV
$I_{SO(SS\_DOM)}$	Short Circuit Current Steady State Output Current, dominant	$V_{CANH} = -5\text{ V}$ to $40\text{ V}$ , CANL = open, TXD = 0 V	-100			mA
		$V_{CANL} = -5\text{ V}$ to $40\text{ V}$ , CANH = open, TXD = 0 V			100	mA
$I_{SO(SS\_REC)}$	Short Circuit Current Steady State Output Current, recessive	$-27\text{ V} \leq V_{BUS} \leq 32\text{ V}$ , $V_{BUS} = \text{CANH} = \text{CANL}$ , TXD = $V_{CCA}$	-5.0		5.0	mA
<b>Receiver Electrical Characteristics</b>						
VIT	Differential Input Threshold Voltage	$ V_{CM}  \leq 20\text{ V}$	500		900	mV
		$20\text{ V} \leq  V_{CM}  \leq 30\text{ V}$	400		1000	
VHYS	Hysteresis Voltage for differential input threshold <sup>(1)</sup>		120		mV	
VCM	Input Common Mode Range		-30		30	V
$I_{OFF(LKG)}$	Power-off Bus Input Leakage Current	CANH = CANL = 5 V, $V_{CCB}$ to GND via 0 $\Omega$ and 47 k $\Omega$ resistor			4.8	$\mu\text{A}$
$C_i$	Input capacitance to ground (CANH or CANL) <sup>(1)</sup>	TXD = $V_{CCA}$		24.0	30	pF
$C_{iD}$	Differential Input Capacitance (CANH – CANL) <sup>(1)</sup>	TXD = $V_{CCA}$		12.0	15	pF
$R_{iD}$	Differential Input Resistance	TXD = $V_{CCA}$ ; $-30\text{ V} \leq V_{CM} \leq +30\text{ V}$	25		80	k $\Omega$
$R_{iN}$	Input Resistance (CANH or CANL)	TXD = $V_{CCA}$ ; $-30\text{ V} \leq V_{CM} \leq +30\text{ V}$	15		40	k $\Omega$

**Isolated CAN Transceiver with Flexible Data Rate**

Parameter		Test Conditions	Min	Typ	Max	Unit
R <sub>IN(M)</sub>	Input Resistance Matching: $(1 - R_{IN(CANH)}/R_{IN(CANL)}) \times 100\%$	V <sub>CANH</sub> = V <sub>CANL</sub> = 5 V	-2.0		2.0	%
<b>Thermal Shutdown</b>						
T <sub>TSD</sub>	Thermal Shutdown Temperature (1)			170		°C
T <sub>TSD_HYST</sub>	Thermal Shutdown Hysteresis (1)			5		°C

(1) Provided by bench test and design simulation.

**Isolated CAN Transceiver with Flexible Data Rate**
**Switching Characteristics**

All test conditions:  $V_{CCA} = 2.25\text{ V} \sim 5.5\text{ V}$ ,  $V_{CCB} = 4.5\text{ V} \sim 5.5\text{ V}$ ,  $T_A = -40^\circ\text{C}$  to  $125^\circ\text{C}$ . Typical value is in  $V_{CCA} = 3.3\text{ V}$ ,  $V_{CCB} = 5\text{ V}$ ,  $T_A = +25^\circ\text{C}$ ., unless otherwise noted.

Parameter	Conditions	Min	Typ	Max	Units		
<b>Switching Characteristics</b>							
$t_{\text{PROP(LOOP1)}}$	Total loop delay, driver input TXD to receiver RXD, recessive to dominant	$R_L = 60\ \Omega$ , $C_L = 100\ \text{pF}$ , $C_{L(\text{RXD})} = 15\ \text{pF}$ ; input rise/fall time (10% to 90%) on TXD < 5 ns; $2.25\text{ V} \leq V_{CCA} \leq 5.5\text{ V}$	80	110	200	ns	
$t_{\text{PROP(LOOP2)}}$	Total loop delay, driver input TXD to receiver RXD, dominant to recessive	$R_L = 60\ \Omega$ , $C_L = 100\ \text{pF}$ , $C_{L(\text{RXD})} = 15\ \text{pF}$ ; input rise/fall time (10% to 90%) on TXD < 5 ns; $2.25\text{ V} \leq V_{CCA} \leq 5.5\text{ V}$	80	120	200	ns	
$t_{\text{UV\_RE\_ENABLE}}$	Re-enable time after undervoltage event	Time for device to return to normal operation from $V_{CCA}$ or $V_{CCB}$ under voltage event		30	50	$\mu\text{s}$	
Static CMTI	Static Common mode transient immunity <sup>(1)</sup>	$V_{\text{CM}} = 1200\text{ V}_{\text{PK}}$	150	200		kV/ $\mu\text{s}$	
Dynamic CMTI	Dynamic Common mode transient immunity <sup>(1)</sup>	$V_{\text{CM}} = 1200\text{ V}_{\text{PK}}$	100	150		kV/ $\mu\text{s}$	
<b>Driver Switching Characteristics</b>							
$t_{\text{pHR}}$	Propagation delay time, HIGH TXD to driver recessive	$R_L = 60\ \Omega$ and $C_L = 100\ \text{pF}$ ; input rise/fall time (10% to 90%) on TXD < 5 ns		65	120	ns	
$t_{\text{pLD}}$	Propagation delay time, LOW TXD to driver dominant			55	120		
$t_{\text{sk(p)}}$	Pulse skew ( $ t_{\text{pHR}} - t_{\text{pLD}} $ ) <sup>(1)</sup>			12	30		
$t_{\text{R}}$	Differential output signal rise time <sup>(1)</sup>			40			
$t_{\text{F}}$	Differential output signal fall time <sup>(1)</sup>			40			
$V_{\text{SYM}}$	Output symmetry (dominant or recessive) ( $V_{O(\text{CANH})} + V_{O(\text{CANL})}$ ) / $V_{\text{CCB}}$	$R_{\text{TERM}} = 60\ \Omega$ , $C_{\text{SPLIT}} = 4.7\ \text{nF}$ , $C_L = \text{open}$ , $R_L = \text{open}$ , TXD = 250 kHz, 1 MHz	0.9		1.1	V/V	
$t_{\text{TXD\_DTO}}$	Dominant time out	$R_L = 60\ \Omega$ and $C_L = \text{open}$	1.2		3.8	Ms	
<b>Receiver Switching Characteristics</b>							
$t_{\text{pRH}}$	Propagation delay time, bus recessive input to RXD high output	$C_{L(\text{RXD})} = 15\ \text{pF}$		60	120	ns	
$t_{\text{pDL}}$	Propagation delay time, bus dominant input to RXD low output				55	120	ns
$t_{\text{R}}$	Output signal rise time (RXD) <sup>(1)</sup>				1	4	ns

**Isolated CAN Transceiver with Flexible Data Rate**

Parameter		Conditions	Min	Typ	Max	Units
$t_F$	Output signal fall time (RXD) <sup>(1)</sup>			1	4	ns
<b>CAN FD Timing parameters</b>						
$t_{BIT(BUS)}$	Bit time on CAN bus output pins with $t_{BIT(TXD)} = 500$ ns	$R_L = 60 \Omega$ , $C_L = 100$ pF, $C_{L(RXD)} = 15$ pF; input rise/fall time (10% to 90%) on TXD < 5 ns	435		530	ns
	Bit time on CAN bus output pins with $t_{BIT(TXD)} = 200$ ns	$R_L = 60 \Omega$ , $C_L = 100$ pF, $C_{L(RXD)} = 15$ pF; input rise/fall time (10% to 90%) on TXD < 5 ns	155		210	ns
$t_{BIT(RXD)}$	Bit time on RXD output pins with $t_{BIT(TXD)} = 500$ ns	$R_L = 60 \Omega$ , $C_L = 100$ pF, $C_{L(RXD)} = 15$ pF; input rise/fall time (10% to 90%) on TXD < 5 ns	400		550	ns
	Bit time on RXD output pins with $t_{BIT(TXD)} = 200$ ns	$R_L = 60 \Omega$ , $C_L = 100$ pF, $C_{L(RXD)} = 15$ pF; input rise/fall time (10% to 90%) on TXD < 5 ns	120		220	ns
$\Delta t_{REC}$	Receiver timing symmetry with $t_{BIT(TXD)} = 500$ ns	$R_L = 60 \Omega$ , $C_L = 100$ pF, $C_{L(RXD)} = 15$ pF; input rise/fall time (10% to 90%) on TXD < 5 ns; $\Delta t_{REC} = t_{BIT(RXD)} - t_{BIT(BUS)}$	-65.0		40	ns
	Receiver timing symmetry with $t_{BIT(TXD)} = 200$ ns	$R_L = 60 \Omega$ , $C_L = 100$ pF, $C_{L(RXD)} = 15$ pF; input rise/fall time (10% to 90%) on TXD < 5 ns; $\Delta t_{REC} = t_{BIT(RXD)} - t_{BIT(BUS)}$	-45.0		15	ns

(1) Provided by bench test and design simulation.

Test Circuits and Waveforms

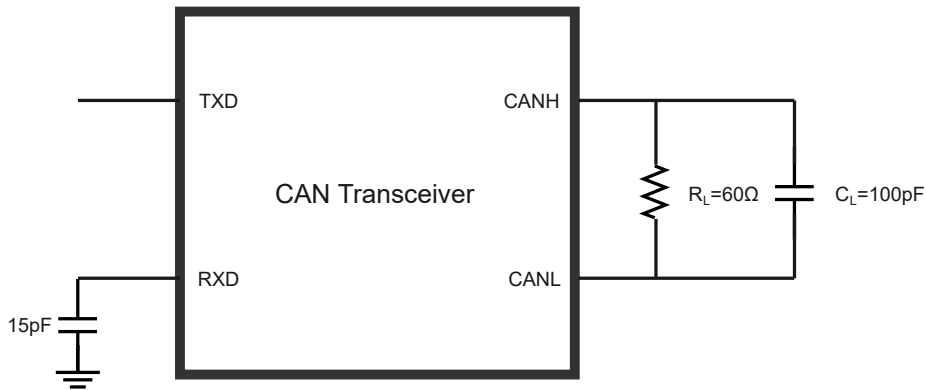

Figure 1. CAN Transceiver Timing Parameter Test Circuit

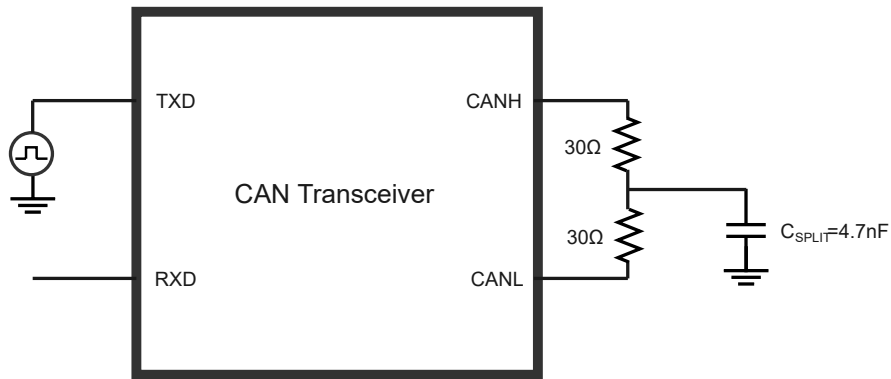

Figure 2. CAN Transceiver Driver Symmetry Test Circuit

Isolated CAN Transceiver with Flexible Data Rate

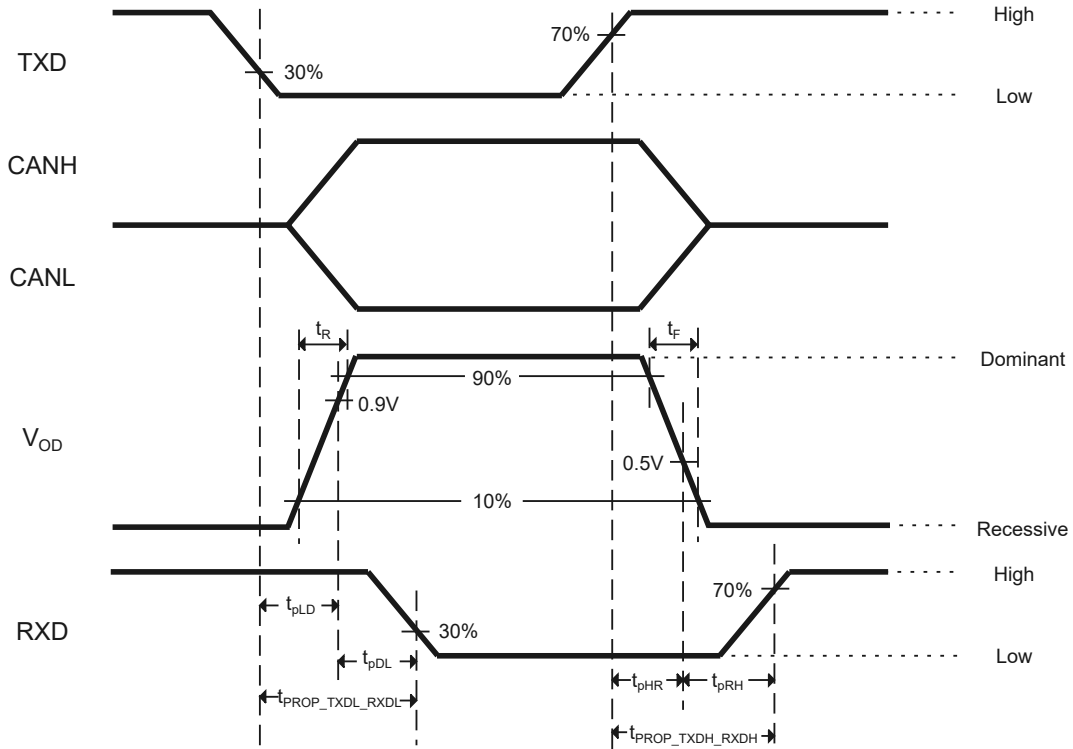

Figure 3. CAN Transceiver Timing Diagram

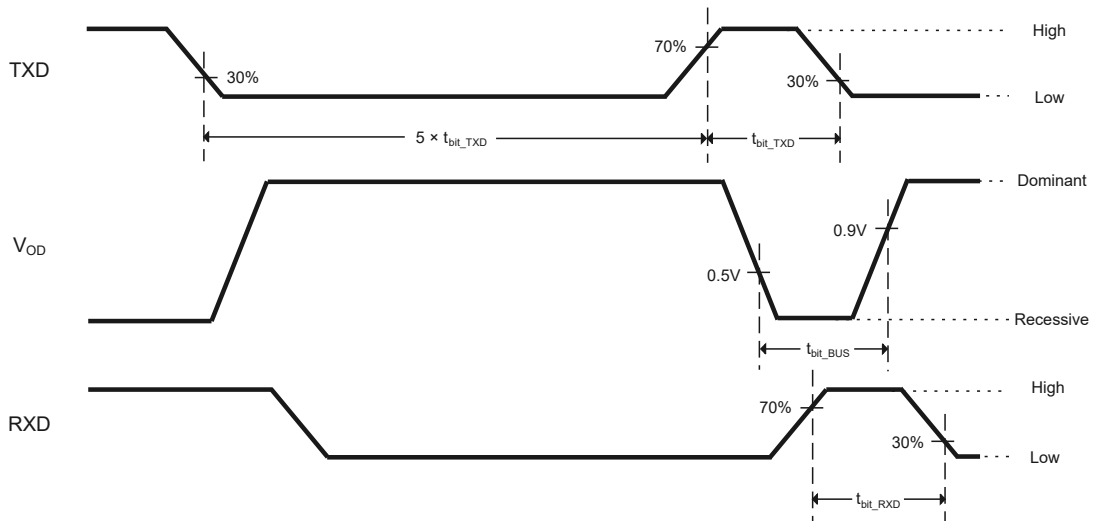

Figure 4. CAN FD Timing Parameter Diagram

Isolated CAN Transceiver with Flexible Data Rate

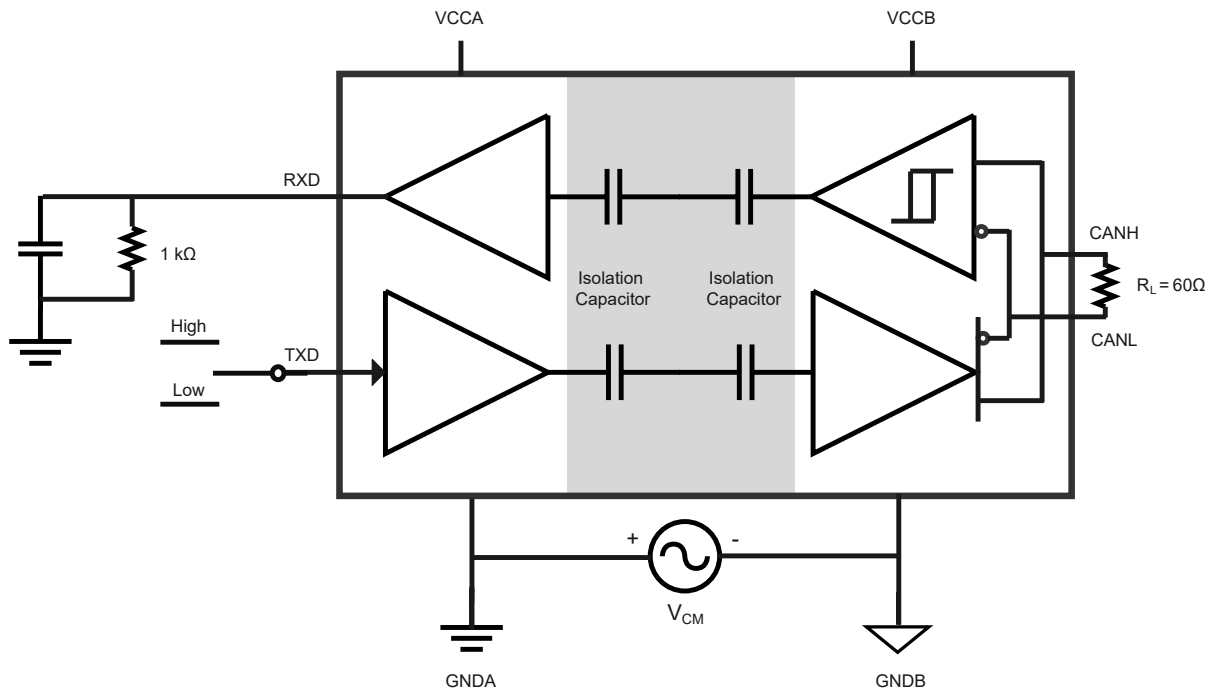

Figure 5. Common-Mode Transient Immunity Test Circuit

## Detailed Description

### Overview

The TPT71044 and TPT71050 devices are isolated CAN transceivers that meet the ISO11898 High-speed CAN (Controller Area Network) physical layer standard. The device utilize an ON-OFF Keying (OOK) modulation circuit to transmit the digital data through the isolation barrier. The transmitter sends a RF carrier to represent digital state one and sends no signal to represent the digital state zero. The devices also utilize advanced circuit design to maximise CMTI performance and minimise radiated emissions. The devices are designed to be applied in CAN FD networks up to 5 Mbps, and to enhance timing margin and higher data rates in long and high-loading networks. As the design, the device features cross-wire, overvoltage, and loss of ground protection from  $-42\text{ V}$  to  $+42\text{ V}$ , overtemperature shutdown, a  $-30\text{ V}$  to  $+30\text{ V}$  common-mode range. The VCCA is the power supply input for RXD and TXD I/O pins which support a wide range from 2.25 V to 5.5 V. The 2<sup>nd</sup> power supply VCCB of CAN BUS side supports a range from 4.5 V to 5.5 V. The difference between TPT71050 and TPT71044 is the TXD and RXD pin position.

### Functional Block Diagram

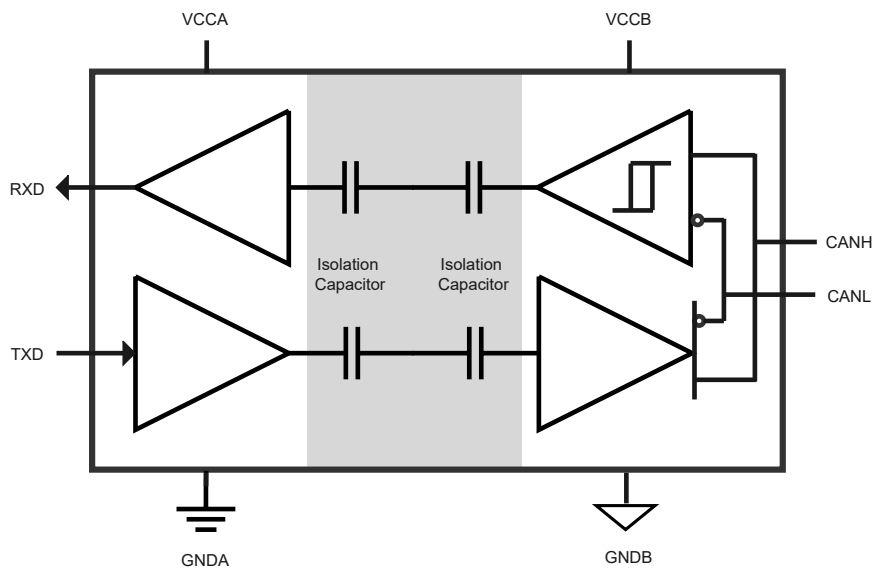

Figure 6. Block Diagram of Digital Capacitive Isolator

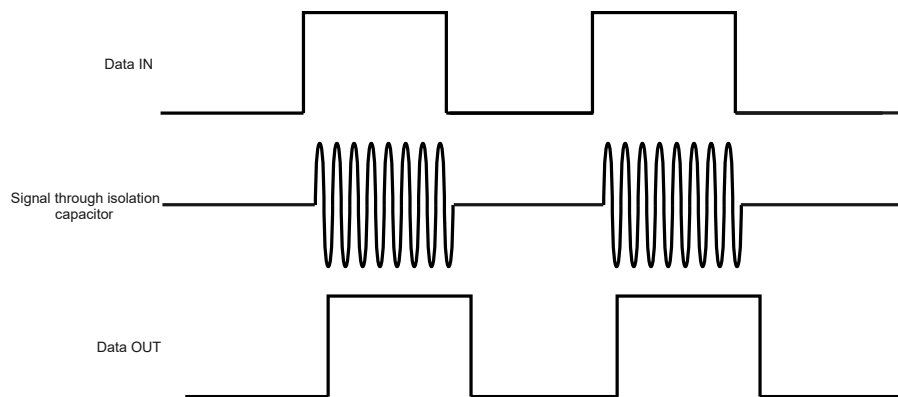

Figure 7. On-Off Keying (OOK) based Modulation Scheme

## Feature Description

### Under-voltage Lockout (UVLO)

The TPT710xx uses an under-voltage lockout circuit to keep the device in shutdown mode until the supply voltage is higher than the UVLO threshold.

### Over Temperature Protection (OTP)

The TPT710xx integrates foldback circuit and over-temperature protection to prevent device from over-heated and damage. When the junction temperature is higher than  $T_{OTP}$ , 150°C, a current thermal foldback circuit starts to work and decrease the device output charge current gradually with  $T_J$  rise. If  $T_J$  still rises and reaches 180°C, the device will shut down charging loop until  $T_J$  drops below 100°C.

### Time-out Function in TXD Dominant Mode

When the TXD pin is set to low, the timer of 'TXD dominant time-out' is started. If the low state on TXD persists for longer than  $t_{TXD\_DTO}$ , the transmitter is disabled and the bus lines are in recessive state. This function prevents a hardware and/or software application failure from driving the bus lines to a permanent dominant state which will block all network communications. The TXD dominant time-out timer is reset as TXD is pulled to high.

### Over-Temperature Protection (OTP)

The output drivers are protected against over-temperature conditions. If the virtual junction temperature exceeds the shutdown junction temperature  $T_{OTP}$ , the output drivers will be disabled until the virtual junction temperature falls below  $T_{OTP}$  and TXD becomes recessive again. Including the TXD condition to ensures output driver oscillation due to temperature drift is avoided.

**Isolated CAN Transceiver with Flexible Data Rate**
**Table 3. Driver Function Table**

Device	Inputs	Outputs		Driven BUS State
	TXD	CANH	CANL	
All Devices	L	H	L	Dominant
	H or Open	Z	Z	Recessive
	X	Z	Z	Recessive

**Table 4. Receiver Function Table**

Device Mode	CAN Differential Inputs $V_{ID}$ $= V_{CANH} - V_{CANL}$	Bus State	RXD Terminal
Normal	$V_{ID} \geq V_{IT+(MAX)}$	Dominant	L
	$V_{IT-(MIN)} < V_{ID} < V_{IT+(MAX)}$	Indeterminate	Indeterminate
	$V_{ID} \leq V_{IT-(MIN)}$	Recessive	H
	Open ( $V_{ID} \approx 0 V$ )	Open	H

## Application and Implementation

### Note

Information in the following application sections is not part of the 3PEAK's component specification and 3PEAK does not warrant its accuracy or completeness. 3PEAK's customers are responsible for determining suitability of components for their purposes. Customers should validate and test their design implementation to confirm system functionality.

## Application Information

The TPT710xx can be used with other components such as a microcontroller, a transformer driver, and a linear voltage regulator to form a fully isolated CAN interface.

## Typical Application

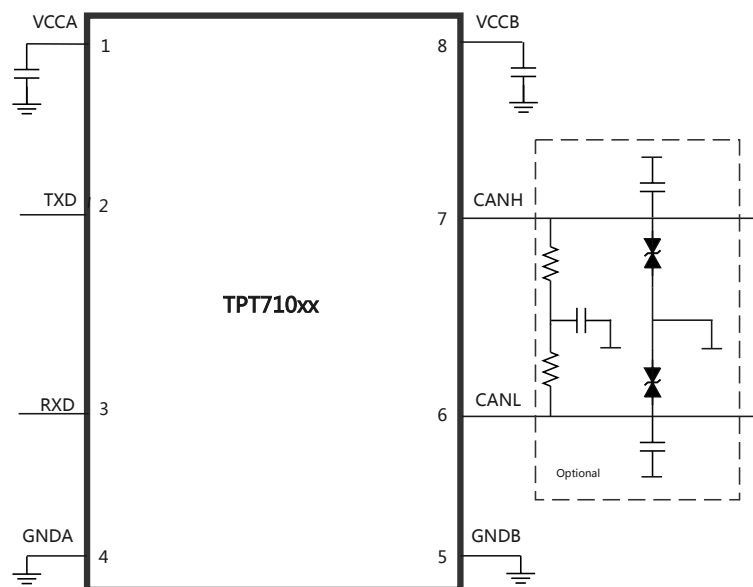

### Tape and Reel Information

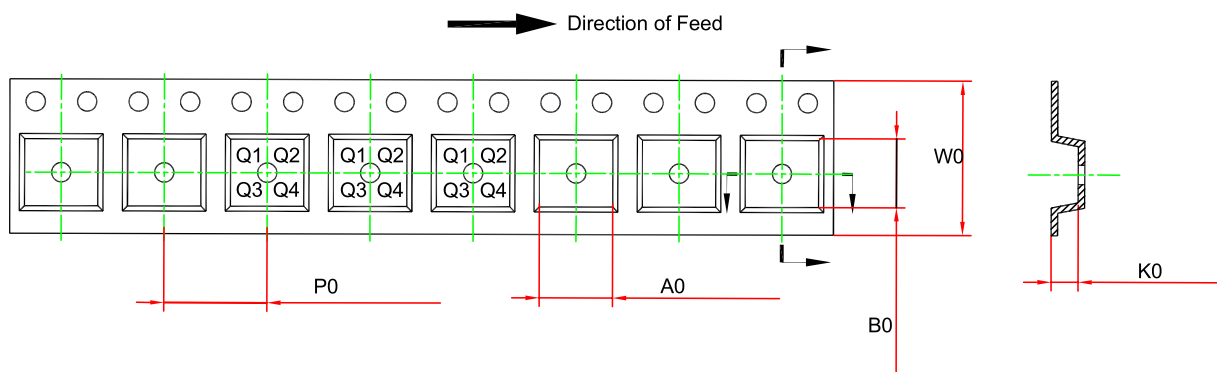
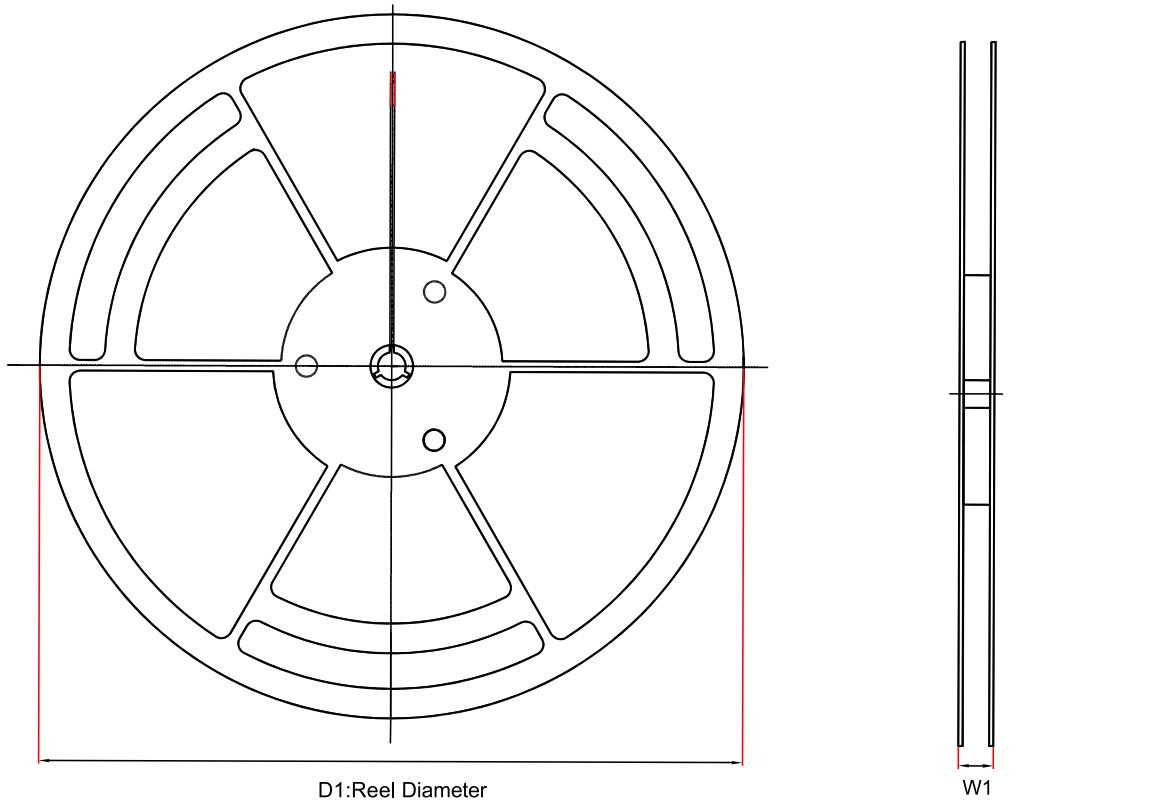

Order Number	Package	D1 (mm)	W1 (mm)	A0 (mm)	B0 (mm)	K0 (mm)	P0 (mm)	W0 (mm)	Pin1 Quadrant
TPT71050-SOBR	WSOP16	330	22.4	10.9	10.8	3.0	12.0	16.0	Q1
TPT71050-SM1R	SMP8	330	29.0	10.9	9.6	4.3	16.0	24.0	Q1
TPT71044-SOAR	WSOP8	330	21.6	11.95	6.2	3.0	16.0	16.0	Q1
TPT71044-SOBR	WSOP16	330	22.4	10.9	10.8	3.0	12.0	16.0	Q1

Package Outline Dimensions

WSOP8-B

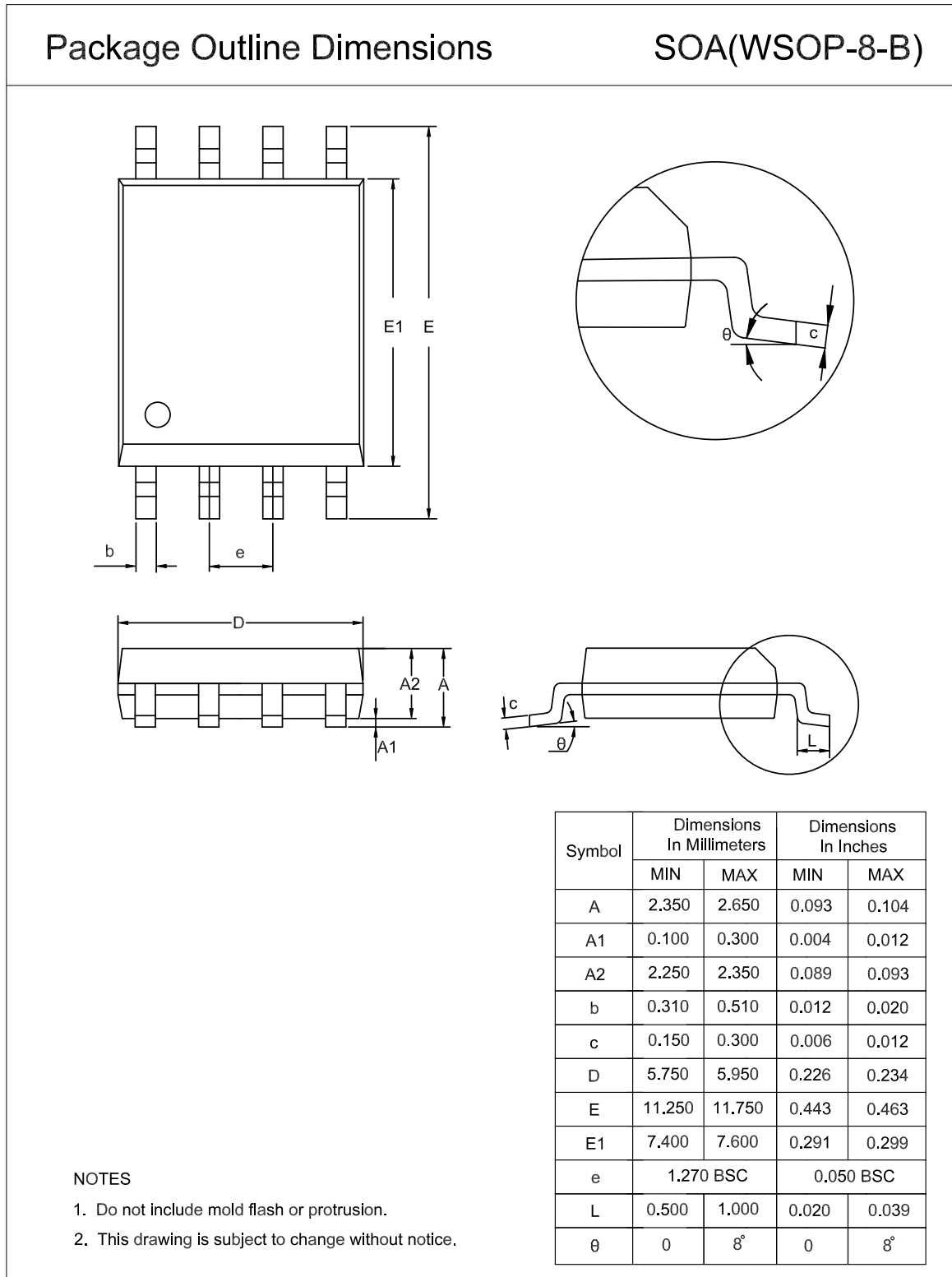

WSOP16

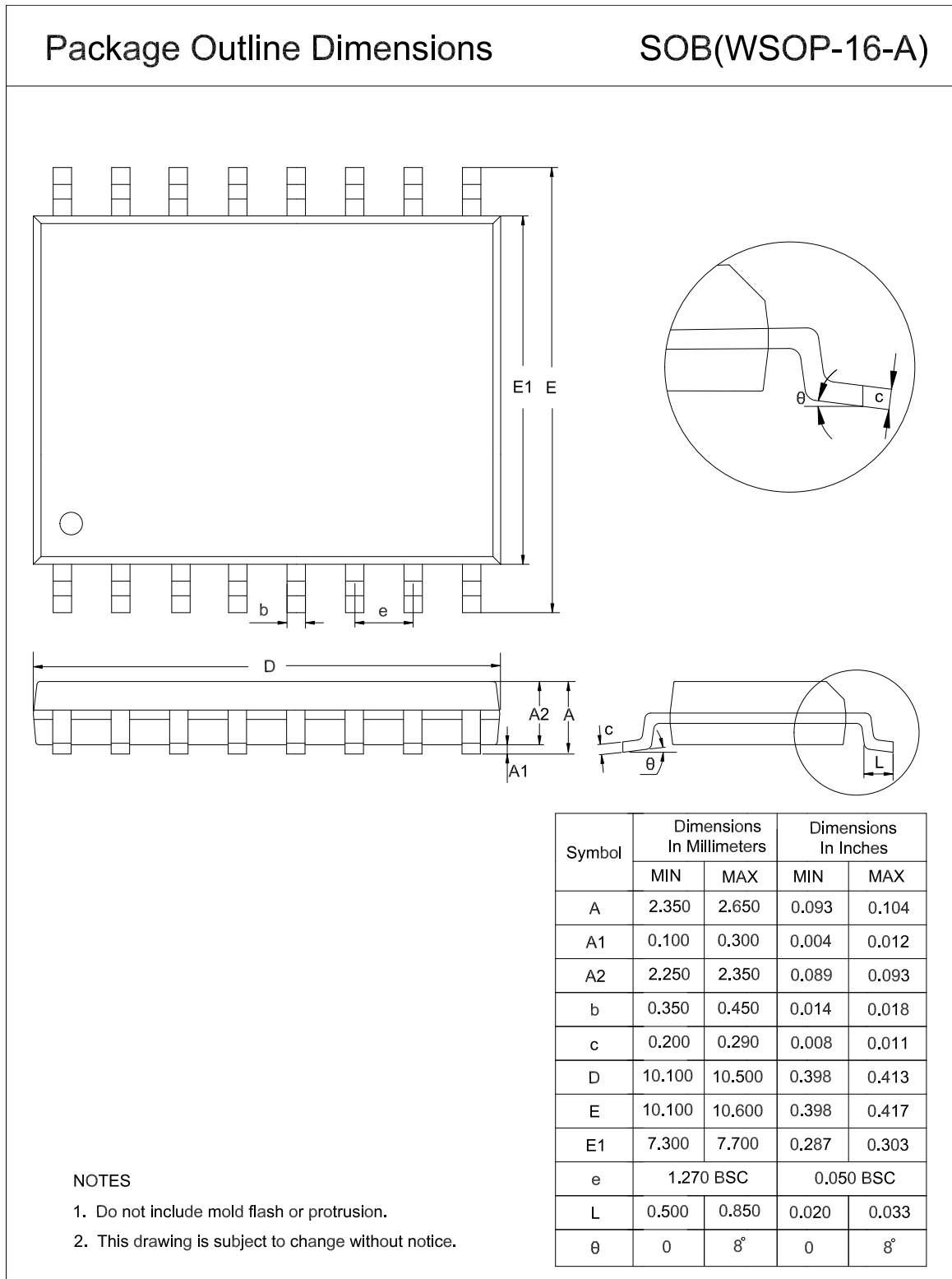

SMP-8

Package Outline Dimensions

SM1(SMP-8-A)

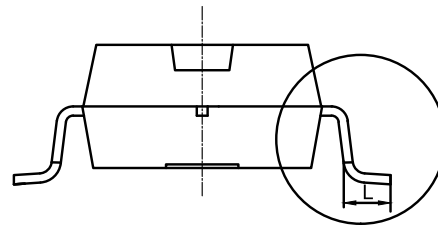
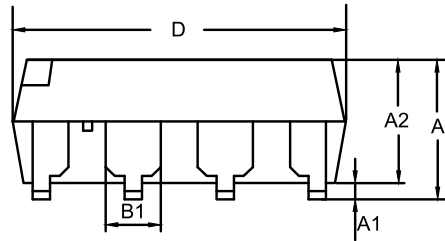
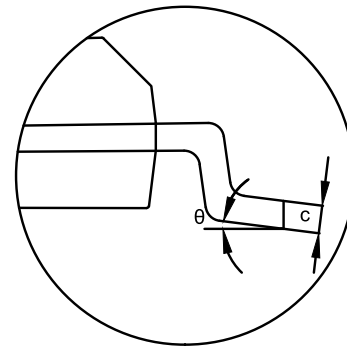
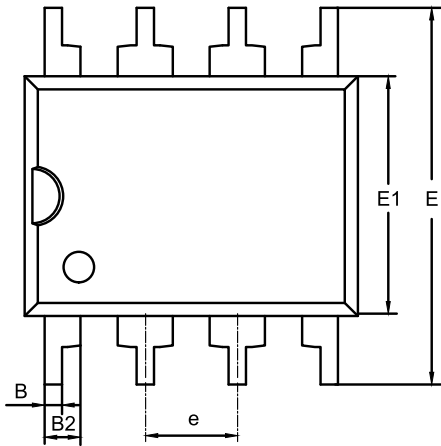

Symbol	Dimensions In Millimeters		Dimensions In Inches	
	MIN	MAX	MIN	MAX
A	3.674	4.026	0.145	0.159
A1	0.350	0.550	0.014	0.022
A2	3.324	3.476	0.131	0.137
B1	1.464	1.584	0.058	0.062
B2	0.930	1.050	0.037	0.041
B	0.420	0.540	0.017	0.021
c	0.204	0.304	0.008	0.012
D	9.100	9.300	0.358	0.366
E	10.100	10.700	0.398	0.421
E1	6.370	6.870	0.251	0.270
e	2.540 BSC		0.100 BSC	
L	1.150	1.450	0.045	0.057
$\theta$	0	8°	0	8°

NOTES

1. Do not include mold flash or protrusion.
2. This drawing is subject to change without notice.

## Order Information

Order Number	Operating Temperature Range	Package	Marking Information	MSL	Transport Media, Quantity	Eco Plan
TPT71050-SM1R	-40 to 125°C	SMP8	71050	MSL3	Tape and Reel, 800	Green
TPT71050-SOBR	-40 to 125°C	WSOP16	71050	MSL3	Tape and Reel, 1500	Green
TPT71044-SOAR	-40 to 125°C	WSOP8	71044	MSL3	Tape and Reel, 1000	Green
TPT71044-SOBR	-40 to 125°C	WSOP16	71044	MSL3	Tape and Reel, 1500	Green

**Green:** 3PEAK defines "Green" to mean RoHS compatible and free of halogen substances.

## **IMPORTANT NOTICE AND DISCLAIMER**

**Copyright**© 3PEAK 2012-2023. All rights reserved.



**Trademarks.** Any of the 思瑞浦 or 3PEAK trade names, trademarks, graphic marks, and domain names contained in this document /material are the property of 3PEAK. You may NOT reproduce, modify, publish, transmit or distribute any Trademark without the prior written consent of 3PEAK.

**Performance Information.** Performance tests or performance range contained in this document/material are either results of design simulation or actual tests conducted under designated testing environment. Any variation in testing environment or simulation environment, including but not limited to testing method, testing process or testing temperature, may affect actual performance of the product.





**Disclaimer.** 3PEAK provides technical and reliability data (including data sheets), design resources (including reference designs), application or other design recommendations, networking tools, security information and other resources "As Is". 3PEAK makes no warranty as to the absence of defects, and makes no warranties of any kind, express or implied, including without limitation, implied warranties as to merchantability, fitness for a particular purpose or non-infringement of any third-party's intellectual property rights. Unless otherwise specified in writing, products supplied by 3PEAK are not designed to be used in any life-threatening scenarios, including critical medical applications, automotive safety-critical systems, aviation, aerospace, or any situations where failure could result in bodily harm, loss of life, or significant property damage. 3PEAK disclaims all liability for any such unauthorized use.

## Looking for pricing, stock, or lifecycle information?

Click below to explore more details on WIN SOURCE:

-  [View TPT71044-SOBR on WIN SOURCE](#)
-  [3Peak Information](#)

## Optimize Your Supply Chain with WIN SOURCE Solutions

-  Global Sourcing Solution
-  Obsolete Management
-  Cost Control Management
-  Shortage Management
-  Alternative Solution
-  Excess Inventory Management