



**THE DATASHEET OF
10018784-10013TLF**





	Type	PRODUCT SPECIFICATION	NUMBER	GS-12-233
	TITLE	PCI EXPRESS™ CONNECTOR		PAGE 1 of 11 REV. H AUTHORIZED BY Richard Chiu DATE 07/04/08

TABLE OF CONTENTS

SECTION 1	INTRODUCTION
SECTION 2	GENERAL REQUIREMENTS
SECTION 3	MECHANICAL
	3.1 EXAMINATION OF PRODUCT
	3.2 INSERTION/WITHDRAWAL FORCES - ADD IN CARD
	3.3 CONTACT RETENTION
	3.4 BOARD INSERTION/RETENTION FORCE
	3.5 SOLDERABILITY
SECTION 4	ELECTRICAL
	4.1 LOW LEVEL CONTACT RESISTANCE
	4.2 INSULATION RESISTANCE
	4.3 DIELECTRIC WITHSTANDING
	4.4 CONTACT CURRENT RATING
	4.5 INSERTION LOSS
	4.6 RETURN LOSS
	4.7 CROSSTALK
SECTION 5	ENVIRONMENTAL
	5.1 THERMAL SHOCK
	5.2 CYCLIC TEMPERATURE AND HUMIDITY
	5.3 TEMPERATURE LIFE (PRE-CONDITIONING)
	5.4 TEMPERATURE LIFE
	5.5 VIBRATION
	5.6 DURABILITY (PRE-CONDITIONING)
	5.7 DURABILITY
	5.8 MIXED FLOWING GAS
	5.9 RESEATING
	5.10 RESISTANCE TO SOLDER HEAT
SECTION 6	TEST MATRIX

This document is the property of and embodies CONFIDENTIAL and PROPRIETARY information of FCI. No part of the information shown on the document may be used in any way or disclosed to others without the written consent of FCI. Copyright FCI.

	Type	PRODUCT SPECIFICATION	NUMBER	GS-12-233	
	TITLE	PCI EXPRESS™ CONNECTOR		PAGE	2 of 11
			AUTHORIZED BY	REV.	H
			Richard Chiu	DATE	07/04/08

1.0 INTRODUCTION

1.1 SCOPE

This document describes the functional and test requirements for the PCI Express™ card-edge connector. The connector is designed to meet the requirements of the PCI Express Card Electromechanical Specification and certain customer specifications not covered by the PCI-SIG document.

1.2 APPLICABLE DOCUMENTS

- 1.2.1 Solderability : BUS-19-002/A
- 1.2.2 PCI Express Card Electromechanical Specification
- 1.2.3 EIA -90, EIA-364-
09,17,20,21,28,31,32,65,70,101,108,638
- 1.2.4 PCI Express Connector High Speed Electrical Test Procedure.
- 1.2.5 FCI drawing, PCI Express connector, inspection & customer copy.
- 1.2.6 FCI drawing, solder washer, 78523 : inspection copy.

1.3 DRAWING PRECEDENCE

In the event of conflict between this document and product prints, the product prints shall take precedence.

2.0 GENERAL REQUIREMENTS

- 2.1 The connector has the following characteristics:
1.00m(0.040") pitch, X1, X4, X8, X16 sizes, through hole or straddle mount configuration, rectangular outline, plastic peg or two forklock holdowns requiring TH holes on PCB.
- 2.2 Visual examination, unless otherwise specified, shall be made at 7X.
- 2.3 Silicone compounds (mold releases, lubricants, etc.) May not be used in the manufacturing processes.
- 2.4 Flammability to be rated UL 94V-0.
- 2.5 Unless otherwise specified, tests that require the use of a pc edge card shall use the following
 - 2.5.1 Card material: FR-4 glass epoxy.
 - 2.5.2 Thickness: 1.57 +/- 0.13 (0.062 +/- 0.005 inch)
 - 2.5.3 Trace material: 0.035 (0.0014 inches), copper.
 - 2.5.4 Trace plating: 0.76 micrometers (30 microinches)
minimum gold over 1.27 micrometers (50 microinches)
minimum unbrushed nickel

This document is the property of and embodies CONFIDENTIAL and PROPRIETARY information of FCI. No part of the information shown on the document may be used in any way or disclosed to others without the written consent of FCI. Copyright FCI.

	Type	PRODUCT SPECIFICATION	NUMBER	GS-12-233	
	TITLE	PCI EXPRESS™ CONNECTOR		PAGE	3 of 11
			AUTHORIZED BY	REV.	H
			Richard Chiu	DATE	07/04/08

2.5.5 Pad and trace design: pad and trace design shall follow PCI Express standard as depicted in customer drawing.

2.6 SOLDER TAIL TERMINATION

Tests requiring termination of the soldertails to a PC board shall be prepared as follows:

- 2.6.1A 2.4mm +/- 0.13 (0.094 +/- 0.005) thick FR-4 glass epoxy board having no internal ground planes with plated thru holes in the pattern specified in AFCI customer drawing, shall be used.
- 2.6.2 Solder washers, AFCI part number 78523-001, shall be applied to the tails, and the connector vapor phase reflowed at 215°C (419°F) for a time not to exceed 2 minutes.

3.0 MECHANICAL REQUIREMENTS

3.1 EXAMINATION OF PRODUCT

Samples must comply to applicable FCI product prints.

3.2 INSERTION / WITHDRAWAL FORCE- ADD IN CARD PER EIA-364-13

Mating cycle is with maximum/minimum thickness gage at a rate of 25.4 mm/minute.

- 3.2.1 Maximum insertion force is 1.15 N max. per contact pair when measured with a 1.70 +0.00/-0.01 (0.067 +0.000/-0.004 inches) thick hardened steel card made to the dimensions shown for the PCI Express expansion board in the FCI customer drawing. The card has a R0.05 min., R0.10 max. (sharp edge) and the surface roughness in connector area to be 0.10 micrometers (4 microinches) maximum.
- 3.2.2 Withdrawal force is 0.15N minimum per contact pair when measured with a 1.44 +0.01/-0.00 (0.067 +0.004/-0.000 inches) thick hardened steel card made to the dimensions shown for the PCI Express expansion board in the FCI customer drawing. The card has a R0.05 min., R0.10 max (sharp edge) and the surface roughness in the connector area to be 0.10 micrometers (4 microinches) maximum.

3.3 CONTACT RETENTION

This document is the property of and embodies CONFIDENTIAL and PROPRIETARY information of FCI. No part of the information shown on the document may be used in any way or disclosed to others without the written consent of FCI. Copyright FCI.

	Type	PRODUCT SPECIFICATION	NUMBER	GS-12-233
	TITLE	PCI EXPRESS™ CONNECTOR		PAGE 4 of 11 REV. H AUTHORIZED BY Richard Chiu DATE 07/04/08

Minimum retention force of terminals in the connector housing to be 5N each. Pull rate to be 1.27 mm/min.

3.4 BOARD RETENTION / INSERTION FORCES

3.4.1 Board retention / insertion forces should be checked on an 1.57 +/- 0.13 (0.062 +/- 0.005 inch) thick segment of FR-4 glass / epoxy circuit board segment with a hole of diameter as described below drilled through. Connectors should have all contacts present. Forces apply to connectors with plastic pegs and metal board locks.

3.4.2 Maximum insertion force(including all types post or straddle mount solder tails) to seat connector in PCB(including straddle mount or through PCB)are:

36 pos	2.14 kg max.
64 pos	3.91 kg max.
98 pos	7.45 kg max.
164 pos	7.45 kg max.

3.5 SOLDERABILITY

Per J-STD-002

- steam age for 1 hour
- contact areas evaluated shall meet 95% minimum coverage.

4.0 ELECTRICAL REQUIREMENTS

Unless otherwise specified, all measurements should be performed in the following ambients:

relative humidity:	50% or less
temperature:	25°C +/- 5°C
barometric pressure:	711 to 812 mm mercury (at sea level)

4.1 LOW LEVEL CONTACT RESISTANCE EIA-364-23

This document is the property of and embodies CONFIDENTIAL and PROPRIETARY information of FCI. No part of the information shown on the document may be used in any way or disclosed to others without the written consent of FCI. Copyright FCI.

Form E-3005
Rev E

GS-01-001

	Type	PRODUCT SPECIFICATION	NUMBER	GS-12-233		
	TITLE	PCI EXPRESS™ CONNECTOR		PAGE	5 of 11	
			AUTHORIZED BY	Richard Chiu	REV.	H
				DATE	07/04/08	

- 4.1.1 Solder connector to pc board per section 2.6 and insert card per section 2.5
- 4.1.2 Resistance measurements should be made from the underside of the pc board to the PTH in the add-in card above the contact pad. The test current shall be 100 milliamperes d.c. max. with a maximum open circuit voltage of 20 millivolts D.C. See figure 1.0 for attachment of current and voltage leads.
- 4.1.3 Requirement is 30 milliohms maximum initial, with change of 10 milliohms maximum after exposure testing.

**CONTACT RESISTANCE TEST SET UP
THROUGH HOLE
FIGURE 1**

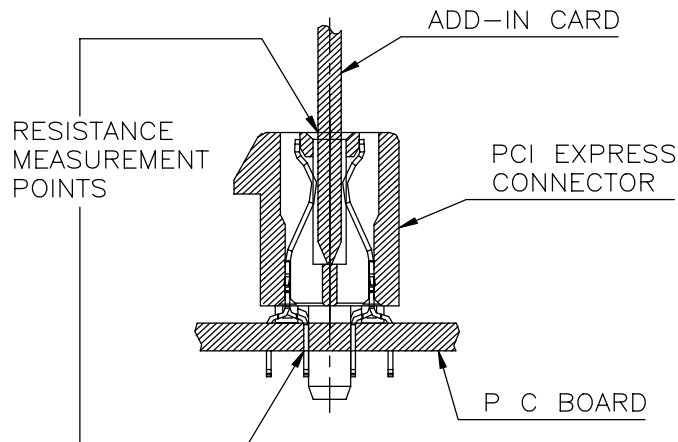

This document is the property of and embodies CONFIDENTIAL and PROPRIETARY information of FCI. No part of the information shown on the document may be used in any way or disclosed to others without the written consent of FCI. Copyright FCI.

Form E-3005
Rev E

GS-01-001

	Type	PRODUCT SPECIFICATION	NUMBER	GS-12-233
	TITLE	PCI EXPRESS™ CONNECTOR		PAGE
			AUTHORIZED BY	Richard Chiu
			DATE	07/04/08

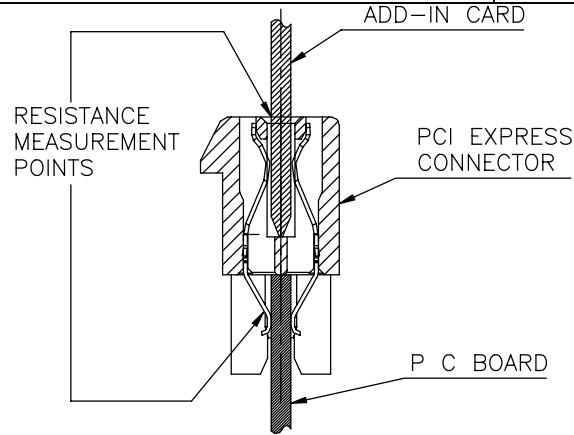

CONTACT RESISTANCE TEST SET UP
STRADDLE MOUNT
FIGURE 2

4.2 INSULATION RESISTANCE

Requirement is 1000 megohm minimum at 100 + / - 10% vdc when tested to EIA-364-21 per spec. The connector shall not be mated during insulation resistance measurement.

4.3 DIELECTRIC WITHSTANDING

Per EIA-364-20 method B per spec. Test potential to be 300 VAC RMS, 60 HZ, and applied for 1 minute. No breakdown should occur. Test is performed with connector unmated.

4.4 CONTACT CURRENT RATING

1.1 amp per contact minimum per EIA-364-70, method 2 and *PCI Express Connector High Speed Electrical Test Procedure*. The temperature rise shall not exceed 30 degree C. Ambient condition is still air at 25°C.

4.5 INSERTION LOSS

Per EIA-364-101 and *PCI Express Connector High Speed Electrical Test Procedure*.
Requirements:

Less than or equal to 1dB up to 1.25 GHz

This document is the property of and embodies CONFIDENTIAL and PROPRIETARY information of FCI. No part of the information shown on the document may be used in any way or disclosed to others without the written consent of FCI. Copyright FCI.

	Type	PRODUCT SPECIFICATION	NUMBER	GS-12-233
	TITLE	PCI EXPRESS™ CONNECTOR		PAGE 7 of 11 REV. H AUTHORIZED BY Richard Chiu DATE 07/04/08

Less than or equal to $1.6 \times (F-1.25)+1$ db between
 1.25GHz and 3.75GHz.
 Less than or equal to 5 dB at 3.75 GHz

4.6 RETURN LOSS

Per EIA-364-108 and *PCI Express Connector High Speed Electrical Test Procedure*.

Requirements:

Less than or equal to -12dB up to 1.3 GHz
 Less than or equal to -7dB up to 2.0 GHz
 Less than or equal to -4dB up to 3.75 GHz

4.7 CROSSTALK: NEXT

Per EIA-90 and *PCI Express Connector High Speed Electrical Test Procedure*.

Requirements:

Less than or equal to -32 dB max up to 1.25 GHz
 Less than or equal to $-(32 - 2.4 \times (F-1.25))$ db between 1.25 GHz and 3.75GHz.
 Less than or equal to -26 dB max up to 3.75 GHz

5.0 ENVIRONMENTAL REQUIREMENTS (Per EIA-364-1000.01)

5.1 THERMAL SHOCK

Per EIA-364-32, test condition I, 10 cycles

5.2 CYCLIC TEMPERATURE AND HUMIDITY

Per EIA-364-31, 24 cycles

5.3 TEMPERATURE LIFE (Pre-conditioning)

Per EIA-364-17, method A, 92 hours at 105°C

5.4 TEMPERATURE LIFE

Per EIA-364-17, method A, 168 hours at 105°C

5.5 VIBRATION

Per EIA-364-28, test condition VII, test condition letter D.
 Requirements: no evidence of physical damage

5.6 DURABILITY (Pre-conditioning)

CYCLE RATE : 500 MATING / HOUR

Per EIA-364-09, 20 cycles

This document is the property of and embodies CONFIDENTIAL and PROPRIETARY information of FCI. No part of the information shown on the document may be used in any way or disclosed to others without the written consent of FCI. Copyright FCI.

	Type PRODUCT SPECIFICATION	NUMBER GS-12-233	
TITLE PCI EXPRESS™ CONNECTOR		PAGE 8 of 11	REV. H
		AUTHORIZED BY Richard Chiu	DATE 07/04/08

5.7 DURABILITY

CYCLE RATE : 500 MATING / HOUR
Per EIA-364-09, 50 cycles

5.8 MIXED FLOWING GAS

Per EIA-364-65, class IIA, 10 days exposure. Expose connectors unmated for 2/3 of the total duration. Mate each connector to the same add-in card that it was mated to in temperature life (preconditioning) and expose for the remainder of the test duration.

5.9 RESEATING

Manually plug/unplug the card and connector, 3 cycles.

5.10 RESISTANCE TO SOLDERING HEAT

Per EIA-364-56 procedure 3, test condition C.
260°±5°C 10±2 seconds

This document is the property of and embodies CONFIDENTIAL and PROPRIETARY information of FCI. No part of the information shown on the document may be used in any way or disclosed to others without the written consent of FCI. Copyright FCI.

	Type	PRODUCT SPECIFICATION	NUMBER	GS-12-233	
	TITLE	PCI EXPRESS™ CONNECTOR		PAGE	9 of 11
			AUTHORIZED BY	REV. H	
			Richard Chiu	DATE	07/04/08

6.0 Test Matrix for 1X,4X,8X,& 16X

TABLE 1 - QUALIFICATION TESTING MATRIX

	TEST GROUP	TEST GROUP	TEST GROUP	TEST GROUP	TEST GROUP	TEST GROUP	TEST GROUP	TEST GROUP	TEST GROUP	TEST GROUP
		1	2	3	4	5	6	7	8	9
TEST	PARA	TEST SEQUENCE								
Examination of Product	3.1	1	1	1	1	1	1	1	1	1
Insertion/Withdrawal Force - Add In Card	3.2					3				
Contact Retention	3.3					5				
Board Retention /Insertion Forces	3.4					2				
Solderability	3.5					4				
Low Level Contact Resistance	4.1	2,5,7	2,5,8,10	2,5,7	2,5,7,9,11			3,5		
Insulation Resistance	4.2		7							
DWV	4.3							2,6		
Contact Current Rating	4.4								2	
Insertion Loss	4.5						2			
Return Loss	4.6						3			
Crosstalk	4.7						4			
Thermal Shock	5.1		4		8					
Cyclic Temp and Humidity	5.2		6							
Temperature Life (pre-conditioning)	5.3			4	4					
Temperature Life	5.4	4								
Vibration	5.5			6						
Durability (pre-conditioning)	5.6	3	3	3	3					
Durability	5.7							4		
Mixed Flowing Gas	5.8				6					
Reseating	5.9	6	9		10					
Resistance to soldering heat	5.10									2
Sample Quantity / Group		16X-5 ⁽¹⁾ 200-5 ⁽¹⁾ 280-5 ⁽¹⁾	16X-5	16X-5 200-5 280-5	16X-10 ⁽²⁾	16X-10,8X-10, 4X-10,1X-10 ⁽³⁾ 200-10, 280-10	4X-3	16X-10 ⁽⁴⁾ 200-10 ⁽¹⁾ 280-10 ⁽¹⁾	16X-4 ⁽⁵⁾	16X-3 Plastic peg 16X-3 board lock

This document is the property of and embodies CONFIDENTIAL and PROPRIETARY information of FCI. No part of the information shown on the document may be used in any way or disclosed to others without the written consent of FCI. Copyright FCI.

	Type PRODUCT SPECIFICATION	NUMBER GS-12-233	
TITLE PCI EXPRESS™ CONNECTOR		PAGE 10 of 11	REV. H
		AUTHORIZED BY Richard Chiu	DATE 07/04/08

Notes:

1. samples for test groups 1,2,3,6 & 8 have metal hold downs, phos bronze contacts and 0.38 micrometers (15 u") gold plate, and black housings.
2. samples for test group 4:
 - a. 5 each same as note 1
 - b. 5 each same as note except with 0.76 micrometers (30u") gold plate.
3. samples for test group 5:
 - a. 5 each same as note 1
 - b. 5 each same as note except with plastic locating pegs.
4. samples for test group 7:
 - a. 5 each same as note 1
 - b. 5 each same as note except with 0.76 micrometers (30U") gold plate.
5. samples for test group 8:
 - a. 2 each same as note 1
 - b. 2 each same as note except with 0.76 micrometers (30U") gold plate.

This document is the property of and embodies CONFIDENTIAL and PROPRIETARY information of FCI. No part of the information shown on the document may be used in any way or disclosed to others without the written consent of FCI. Copyright FCI.

	Type	PRODUCT SPECIFICATION	NUMBER	GS-12-233
	TITLE	PCI EXPRESS™ CONNECTOR		PAGE 11 of 11 REV. H AUTHORIZED BY Richard Chiu DATE 07/04/08



REVISION RECORD

REV	PAGE	DESCRIPTION	ECR #	DATE
A	ALL	RELEASED	T03-0302	07/21/2003
B	ALL	Add 5.10 on Sheet 7 Add group 9 on sheet 8	T03-0463	10/17/03
c	ALL	Modify 5.8 on sheet 7	T03-0513	11/24/03
D	ALL	3.2 add PER EIA-364-13 & cycle rate 4.1 add PER EIA-364-23 5.6 & 5.7 add cycle rate	T04-0114	03/10/04
E	ALL	ADD STRADDLE MOUNT TYPE	T04-0341	08/04/04
F	ALL	ADD 3.4.3	T04-0414	11/23/04
G	ALL	MODIFY 3.4.2, REMOVE 3.4.3 AND CHANGE FORM	T06-0120	06/20/06
H	4	SOLDERABILITY-REFERENCE DOCUMENT WAS REPLACED BY "J-STD-002"	T08-1128	07/04/08

This document is the property of and embodies CONFIDENTIAL and PROPRIETARY information of FCI. No part of the information shown on the document may be used in any way or disclosed to others without the written consent of FCI. Copyright FCI.

Looking for pricing, stock, or lifecycle information?

Click below to explore more details on WIN SOURCE:

-  [View 10018784-10013TLF on WIN SOURCE](#)
-  [Amphenol Information](#)

Optimize Your Supply Chain with WIN SOURCE Solutions

-  Global Sourcing Solution
-  Obsolete Management
-  Cost Control Management
-  Shortage Management
-  Alternative Solution
-  Excess Inventory Management