



**THE DATASHEET OF  
E-TEA3718SFP**



### Features

- Half-step and full-step mode
- Bipolar drive of stepper motor for maximum motor performance
- Built-in protection diodes
- Wide range of current control 5 to 1500 mA
- Wide voltage range 10 to 50 V
- Designed for unstabilized motor supply voltage
- Current levels can be selected in steps or varied continuously
- Thermal overload protection
- Alarm output or pre-alarm output

### Applications

The TEA3718 is a bipolar monolithic integrated circuit intended to control and drive the current in one winding of a bipolar stepper motor.

### Description

The circuits consist of an LS-TTL compatible logic input, a current sensor, a monostable and an output stage with built-in protection diodes. Two TEA3718 ICs and a few external components form a complete control and drive unit for LS-TTL or microprocessor-controlled stepper motor systems.

**Table 1. Device summary**

Order code	Package
E-TEA3718SDP	Power DIP
E-TEA3718DP	
E-TEA3718SFP	SO20
E-TEA3718SFPTR	SO20 (tape and reel)
E-TEA3718SP	Multiwatt™ 15

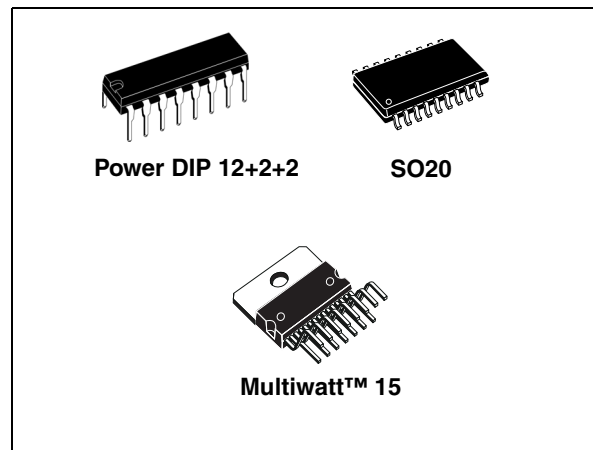

**Figure 1. Block diagram**

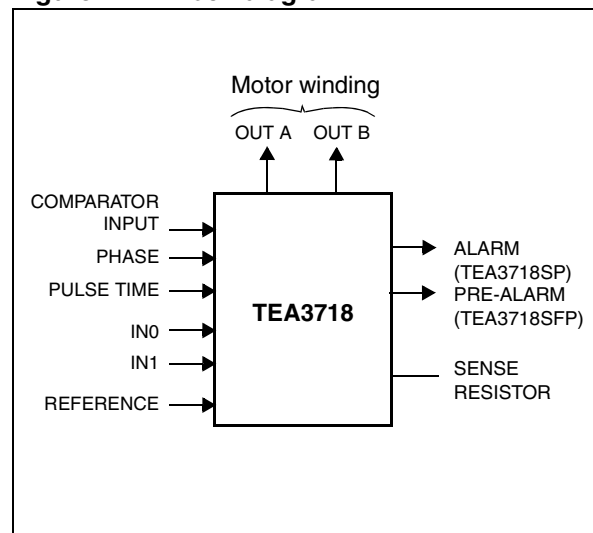

TM: Multiwatt is a trademark of STMicroelectronics

# 1 Pin connections

Figure 2. Package pin locations (top views)

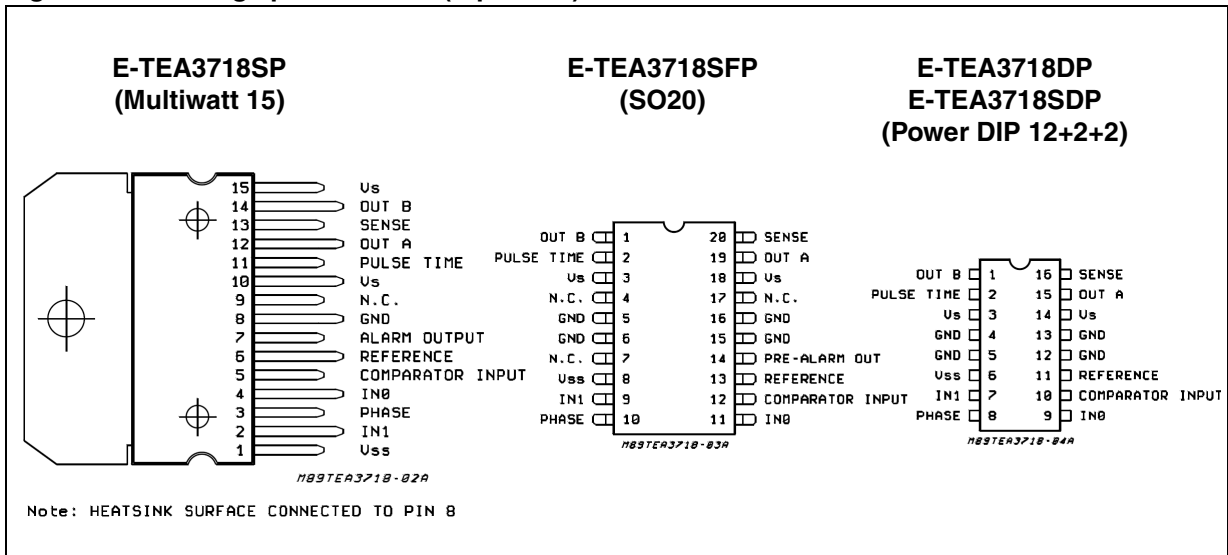

---

# Contents

<b>1</b>	<b>Pin connections</b> .....	<b>2</b>
<b>2</b>	<b>Device diagrams</b> .....	<b>5</b>
<b>3</b>	<b>Electrical specifications</b> .....	<b>7</b>
3.1	Absolute maximum ratings .....	7
3.2	Recommended operating conditions .....	7
3.3	Thermal data .....	8
3.4	Electrical characteristics .....	10
<b>4</b>	<b>Functional blocks</b> .....	<b>13</b>
4.1	Alarm output (TEA3718SP, TEA3718DP and TEA3718SDP) .....	14
4.2	Pre-alarm output (TEA3718SFP) .....	15
4.3	Current reduction in alarm condition .....	15
4.4	Typical application .....	16
<b>5</b>	<b>Functional description</b> .....	<b>17</b>
5.1	Input logic .....	17
5.2	Phase input .....	17
5.3	Current sensor .....	17
5.4	Single-pulse generator .....	18
5.5	Output stage .....	18
5.6	$V_{SS}$ , $V_S$ and $V_R$ .....	18
5.7	Analog control .....	18

## Contents

---

<b>6</b>	<b>Application notes</b> .....	<b>19</b>
6.1	Motor selection .....	19
6.2	Unused inputs .....	19
6.3	Interference .....	19
6.4	Operating sequence .....	20
<b>7</b>	<b>Package mechanical data</b> .....	<b>21</b>
	<b>Revision history</b> .....	<b>25</b>

## 2 Device diagrams

Figure 3. Detailed block diagram (TEA3718SFP)

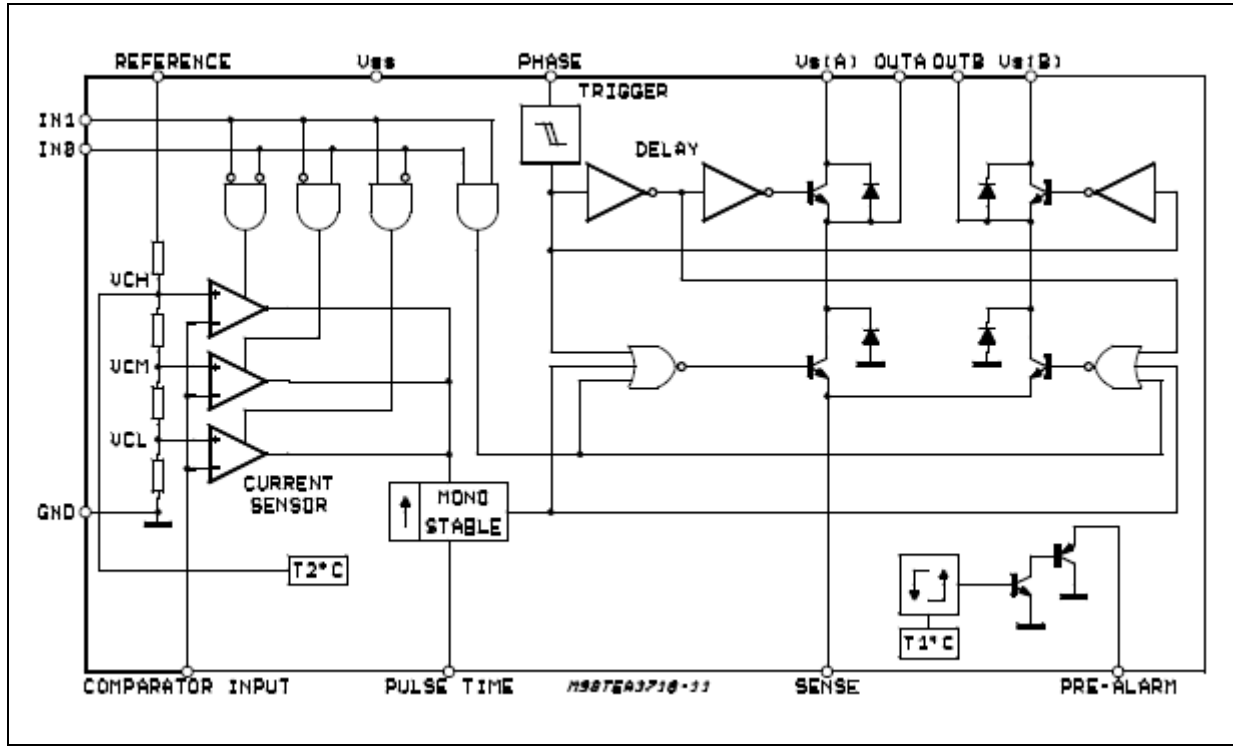
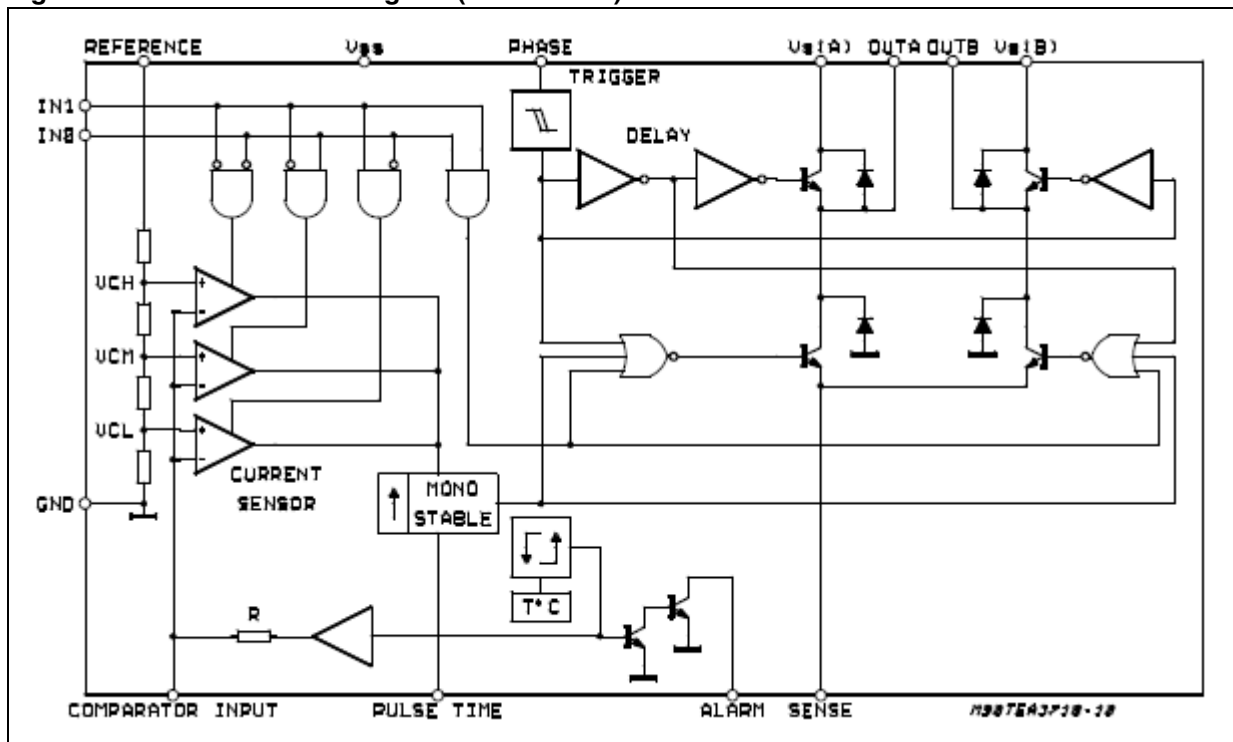

Figure 4. Detailed block diagram (TEA3718SP)



## Device diagrams

**Table 2. Pin functions**

Name	Function
OUTB	Output connection (with pin OUT A). The output stage is a "H" bridge formed by four transistors and four diodes suitable for switching applications.
PULSE TIME	A parallel RC network connected to this pin sets the OFF time of the lower power transistors. The pulse generator is a monostable triggered by the rising edge of the output of the comparators ( $t_{off} = 0.69 R_T C_T$ ).
V <sub>S</sub> (B)	Supply voltage input for half output stage
GND	Ground connection. In SO20 and power DIP these pins also conduct heat from die to printed circuit copper.
V <sub>SS</sub>	Supply voltage input for logic circuitry
IN1	This pin and pin IN0 are logic inputs which select the outputs of three comparators to set the current level. Current also depends on the sensing resistor and reference voltage. See <a href="#">Table 8: Truth table</a> .
PHASE	This TTL-compatible logic input sets the direction of current flow through the load. A high level causes current to flow from OUT A (source) to OUT B (sink). A Schmidt trigger on this input provides good noise immunity and a delay circuit prevents output stage short circuits during switching.
IN0	See IN1
COMPARATOR INPUT	Input connected to the three comparators. The voltage across the sense resistor is feedback to this input through the low pass filter RCCC. The lower power transistor are disabled when the sense voltage exceeds the reference voltage of the selected comparator. When this occurs the current decays for a time set by $R_T C_T$ , $T_{off} = 0.69 R_T C_T$ .
REFERENCE	A voltage applied to this pin sets the reference voltage of the three comparators. Reference voltage with the value of R <sub>S</sub> and the two inputs IN0 and IN1 determines the output current.
V <sub>S</sub> (A)	Supply voltage input for half output stage
OUTA	See pin OUT B
SENSE RESISTOR	Connection to lower emitters of output stage for insertion of current sense resistor
ALARM	When T <sub>j</sub> reaches T1 °C the alarm output becomes low (TEA3718SP)
PRE-ALARM	When T <sub>j</sub> reaches T2 °C the pre-alarm output becomes low (T2<T1) (TEA3718SFP)

**Table 3. Device comparison table**

Device	Current	Package	Alarm	Pre-alarm
TEA3718SDP	1.5 A	Power DIP 12+2+2		Not connected
TEA3718SFP	1.5 A	SO20		Connected
TEA3718SP	1.5 A	Multiwatt 15	Connected	
TEA3718DP	1.5 A	Power DIP 12+2+2	Not connected	

## 3 Electrical specifications

### 3.1 Absolute maximum ratings

Table 4. Absolute maximum ratings

Symbol	Parameters	Value	Unit
$V_{SS}$ $V_S$	Supply voltage	7 50	V
$V_I$	Input voltage: – logic inputs – analog inputs – reference input	6 $V_{SS}$ 15	V
$i_i$	Input current: – logic inputs – analog inputs	-10 -10	mA
$I_O$	Output current	$\pm 1.5$	A
$T_J$	Junction temperature	+150	$^{\circ}\text{C}$
$T_{op}$	Operating ambient temperature range	0 to 70	$^{\circ}\text{C}$
$T_{stg}$	Storage temperature range	-55 to +150	$^{\circ}\text{C}$

### 3.2 Recommended operating conditions

Table 5. Recommended operating conditions

Symbol	Parameters	SO20	Power DIP	Multiwatt 15	Unit
$V_{SS}$	Supply voltage	4.75	5	5.25	V
$V_S$	Supply voltage	10	-	45	V
$I_m$	Output current	0.020	-	1.2	A
$T_{amb}$	Ambient temperature	0	-	70	$^{\circ}\text{C}$
$t_r$	Rise time for logic inputs	-	-	2	$\mu\text{s}$
$t_f$	Fall time for logic inputs	-	-	2	$\mu\text{s}$

### 3.3 Thermal data

Table 6. Thermal data

Symbol	Parameters	SO20	Power DIP	Multiwatt 15	Unit
$R_{th(j-c)}$	Maximum junction-case thermal resistance	16	11	3	$^{\circ}\text{C}/\text{W}$
$R_{th(j-a)}$	Maximum junction-ambient thermal resistance	60 <sup>(1)</sup>	45 <sup>(1)</sup>	40	$^{\circ}\text{C}/\text{W}$

1. Soldered on a 35  $\mu\text{m}$  thick 4  $\text{cm}^2$  PC board copper area

Figure 5. Maximum power dissipation

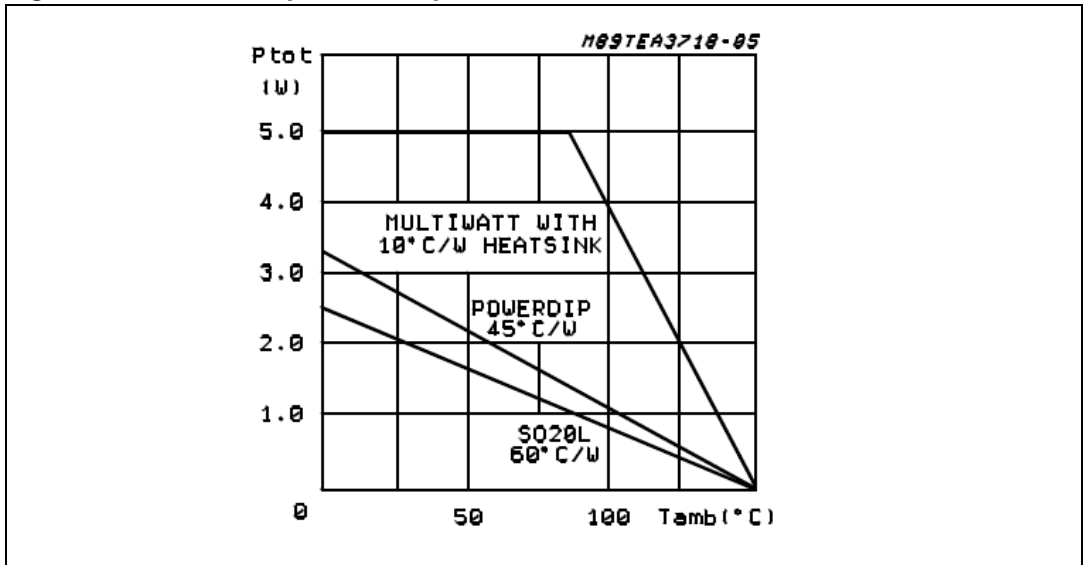

Figure 6. Typical external component configuration

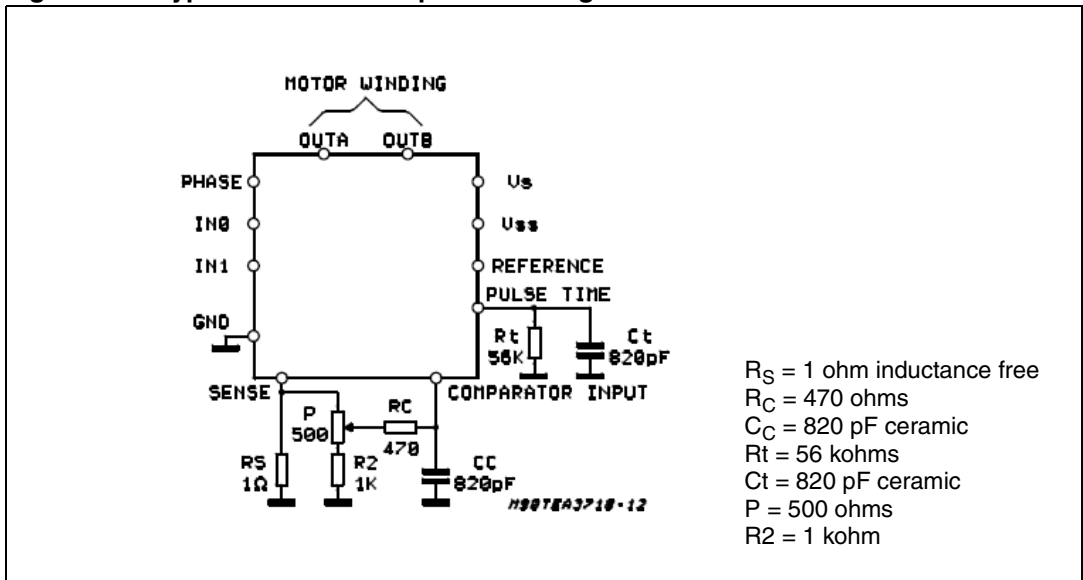
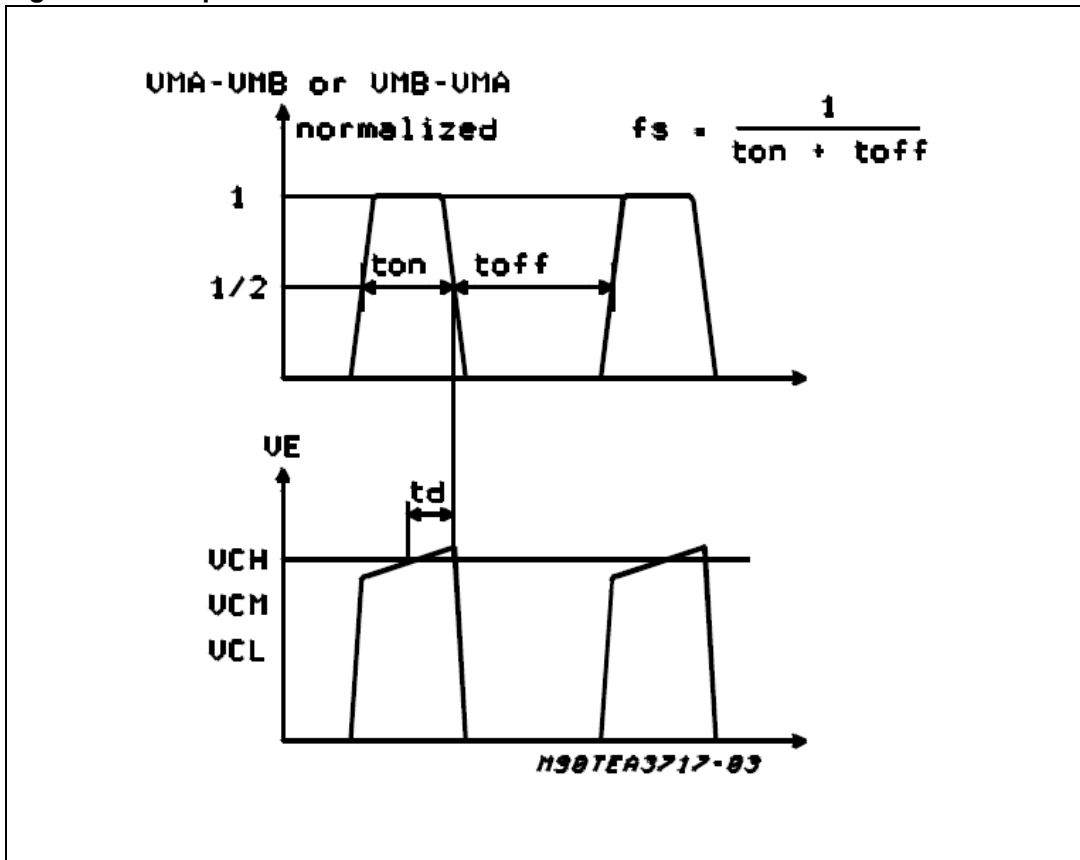

Figure 7. Output waveforms



### 3.4 Electrical characteristics

**Table 7. Electrical characteristics<sup>(1)</sup>**

Symbol	Parameter	Min. <sup>(2)</sup>	Typ. <sup>(2)</sup>	Max. <sup>(2)</sup>	Unit	
I <sub>CC</sub>	Supply current	-	-	25	mA	
V <sub>IH</sub>	High level input voltage - logic inputs 2	2	-	-	V	
V <sub>IL</sub>	Low level input voltage - logic inputs	-	-	0.8	V	
I <sub>IH</sub>	High level input current - logic inputs	-	-	20	μA	
I <sub>IL</sub>	Low level input current - logic inputs (V <sub>I</sub> = 0.4 V)	-0.4	-	-	mA	
V <sub>CH</sub> V <sub>CM</sub> V <sub>CL</sub>	Comparator threshold voltage (VR = 5V) I <sub>O</sub> = 0, I <sub>I</sub> = 0 I <sub>O</sub> = 0, I <sub>I</sub> = 0 I <sub>O</sub> = 0, I <sub>I</sub> = 0	390 230 65	420 250 80	440 270 90	mV	
I <sub>CO</sub>	Comparator input current	-20	-	20	μA	
I <sub>off</sub>	Output leakage current (I <sub>O</sub> = 0, I <sub>I</sub> = 1 T <sub>amb</sub> = 25°C)	-	-	100	μA	
V <sub>sat(total)</sub>	Total saturation voltage drop (I <sub>m</sub> = 1 A) SO20/Power DIP Multiwatt	- -	- -	2.8 3.2	V	
P <sub>tot</sub>	Total power dissipation - I <sub>m</sub> = 1 A, f <sub>s</sub> = 30 kHz	-	3.1	3.6	W	
t <sub>off</sub>	Cut off time (see <a href="#">Figure 6</a> and <a href="#">Figure 7</a> , V <sub>mm</sub> = 10 V V <sub>ton</sub> > 5 μs)	25	30	35	ms	
t <sub>d</sub>	Turn off delay (see <a href="#">Figure 6</a> and <a href="#">Figure 7</a> ) T <sub>amb</sub> = 25°C, dVC/dt > 50 mV/μs)	-	1.6	-	μs	
V <sub>sat(alarm)</sub>	Alarm output saturation voltage I <sub>O</sub> = 2 mA (Multiwatt)	-	0.8	-	V	
I <sub>ref</sub>	Reference input current, VR = 5 V	-	0.4	1	mA	
V <sub>sat(source)</sub>	Source diode transistor pair saturation voltage	Power DIP I <sub>m</sub> = 0.5 A	-	1.05	1.2 (1.3)	V
		Power DIP I <sub>m</sub> = 1 A	-	1.35	1.5 (1.7)	
		Multiwatt I <sub>m</sub> = 0.5 A	-	-	1.3	V
		Multiwatt I <sub>m</sub> = 1 A	-	-	1.7	
V <sub>f(source diode)</sub>	Source diode forward voltage	I <sub>f(source)</sub> = 0.5 A	-	1.1	1.5 (1.6)	V
		I <sub>f(source)</sub> = 1 A	-	1.25	1.7 (1.9)	
I <sub>sub</sub>	Substrate leakage current	I <sub>f</sub> = 1 A	-	-	5	mA
V <sub>sat(sink)</sub>	Sink diode transistor pair saturation	Power DIP I <sub>m</sub> = 0.5 A	-	1	1.2 (1.3)	V
		Power DIP I <sub>m</sub> = 1 A	-	1.2	1.3 (1.5)	
		Multiwatt I <sub>m</sub> = 0.5 A	-	-	1.3	V
		Multiwatt I <sub>m</sub> = 1 A	-	-	1.5	
V <sub>f(sink diode)</sub>	Sink diode forward voltage	I <sub>f(sink)</sub> = 0.5 A	-	1	1.4 (1.6)	V
		I <sub>f(sink)</sub> = 1 A	-	1.1	1.5 (1.9)	

- V<sub>s</sub> = V<sub>ss</sub> = 5 V, ± 5%, V<sub>mm</sub> = 10 V to 45V, T<sub>amb</sub> = 0 to 70oC (T<sub>amb</sub> = 25 °C for TEA3718SFP) unless otherwise specified.
- Values in parentheses apply only to E-TEA3718SFP and E-TEA3718SFPTR mounted in SO20 package.

Figure 8. Sink driver  $V_{CE\ sat}$  against  $I_{out}$  and  $T_j$

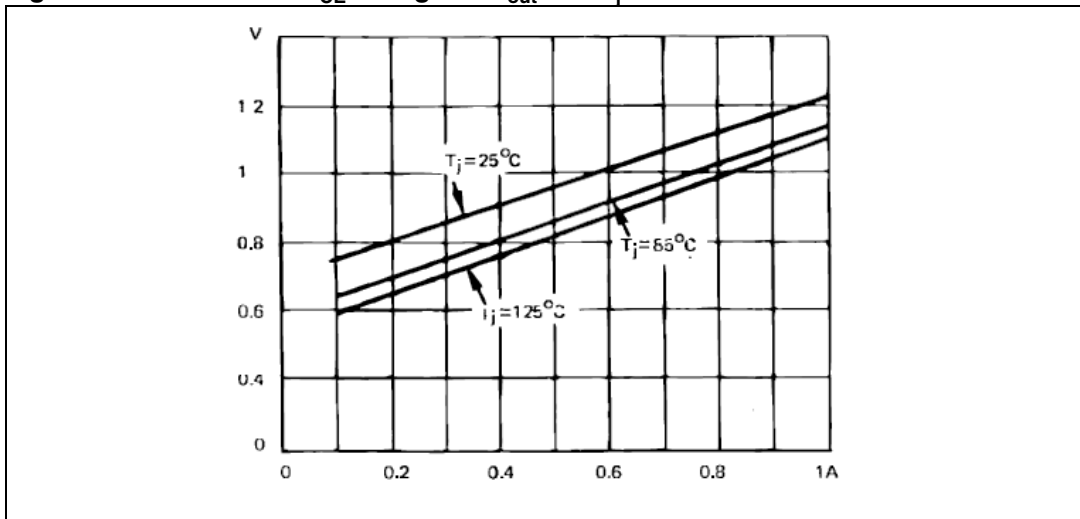

Figure 9. Lower diode  $V_f$  against  $I_{OUT}$  and  $T_j$

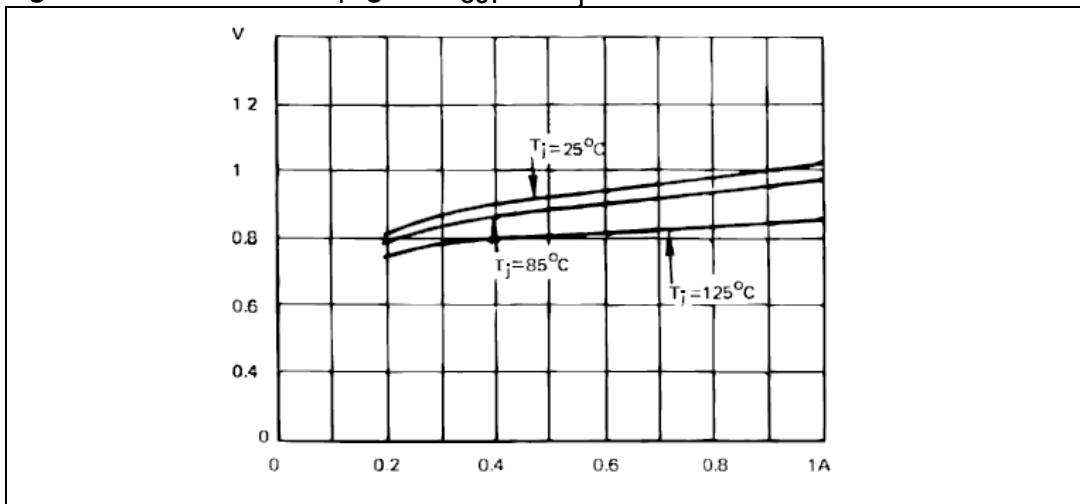

Figure 10. Source driver  $V_{CE\ sat}$  against  $I_{OUT}$  and  $T_j$

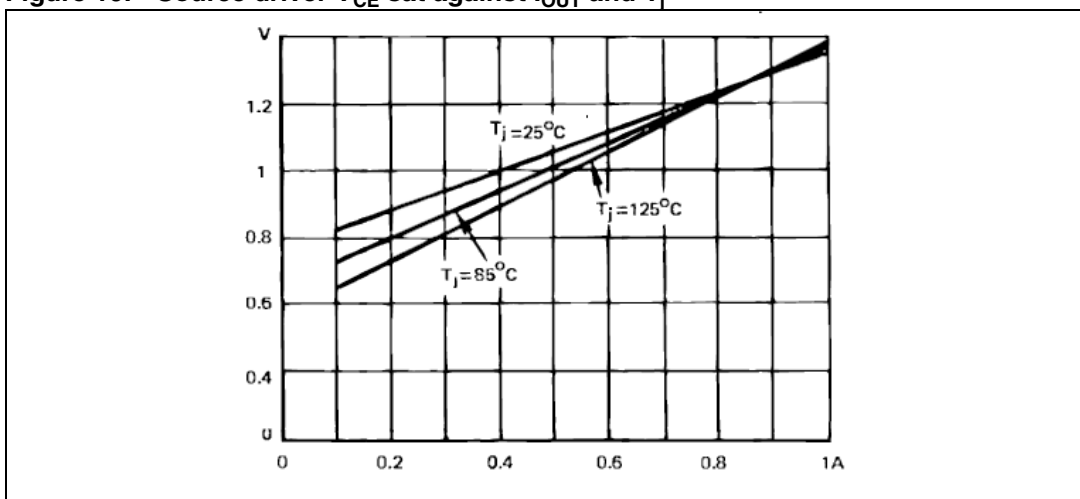

Figure 11. Upper diode  $V_f$  against  $I_{OUT}$  and  $T_j$

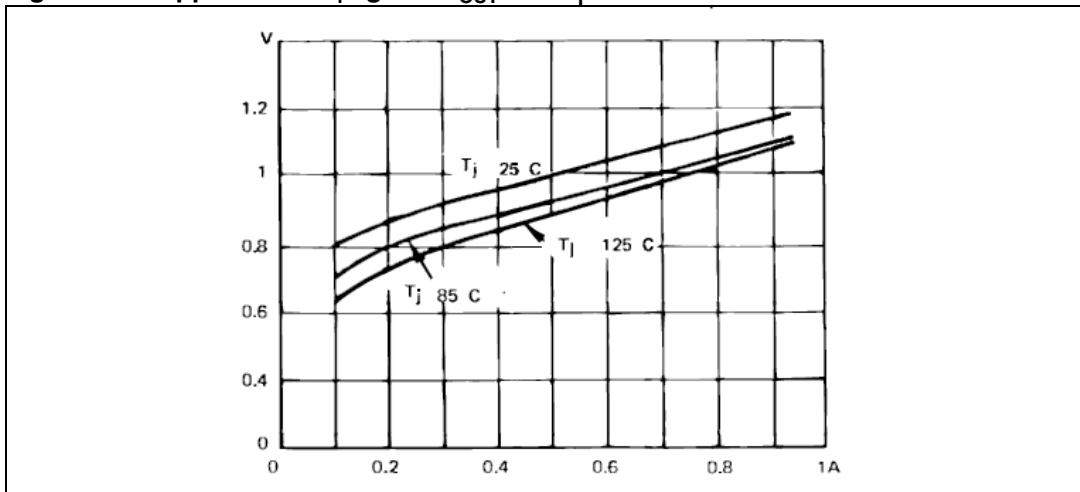

Figure 12.  $I_{ref}$  against junction temperature

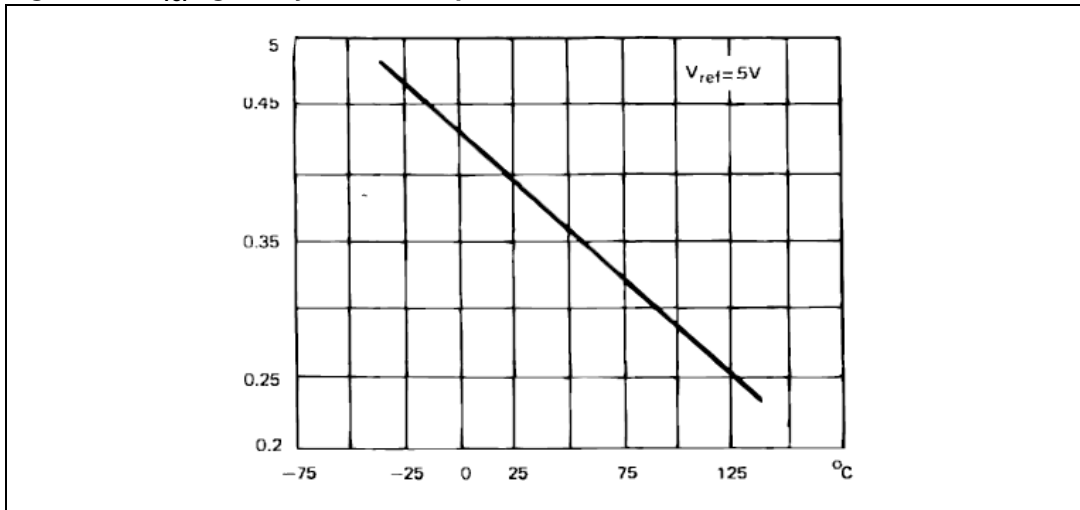
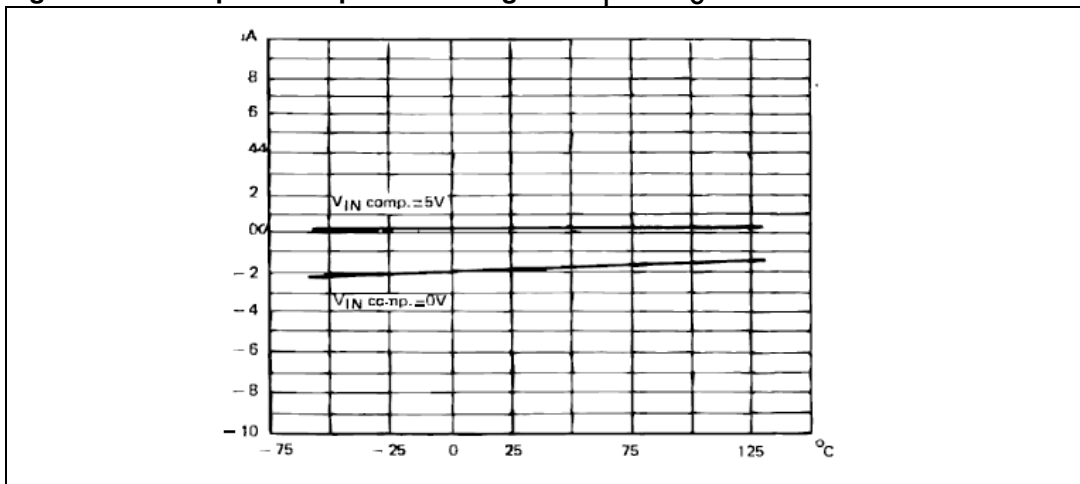

Figure 13. Comparator input current against  $T_j$  and  $V_C$





### 4.1 Alarm output (TEA3718SP, TEA3718DP and TEA3718SDP)

The ALARM output pin becomes low when the junction temperature reaches T °C. When an alarm condition occurs, parts of the supply voltage (dividing bridge R - R<sub>C</sub>) is fed to the comparator input pin (Figure 16). Depending on the R<sub>C</sub> value the behavior of the circuit on an alarm condition is as follows:

- R<sub>C</sub> > 80 ohms, the output stage is switched off
- R<sub>C</sub> > 60 ohms, the current in the motor windings is reduced according to the approximate formula: (see also Figure 18 and Figure 19)

$$I_m = \frac{V_{TH}}{R_S} - \frac{V_{CC}}{R + R_C} \cdot \frac{R_C}{R_S}$$

with V<sub>TH</sub> = threshold of the comparator (V<sub>CH</sub>, V<sub>CM</sub>, V<sub>CL</sub>) R = 700 ohms (typical).

For several Multiwatt packages a common detection can be obtained as in Figure 17.

Figure 16. Alarm detection for power DIP package

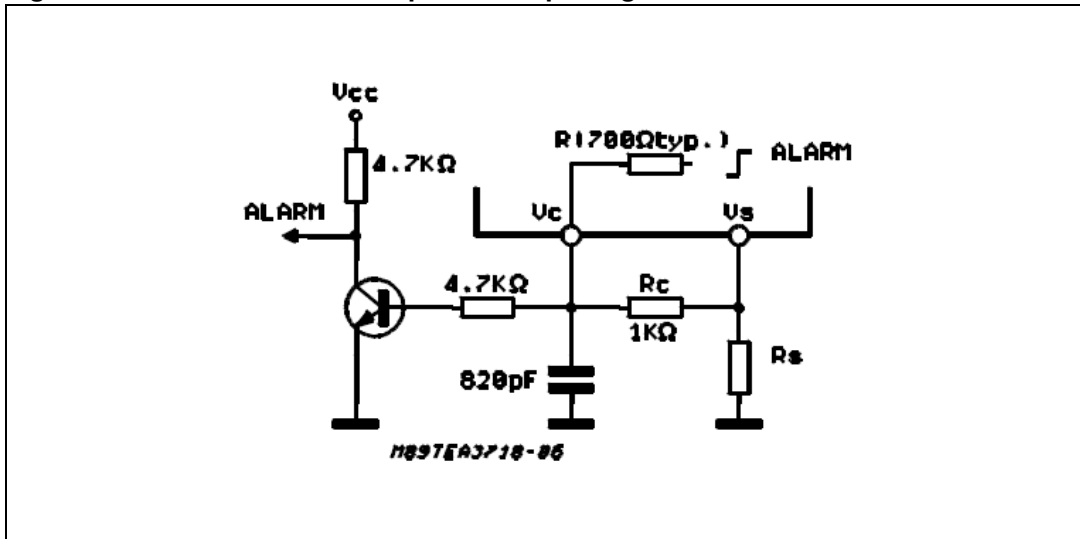
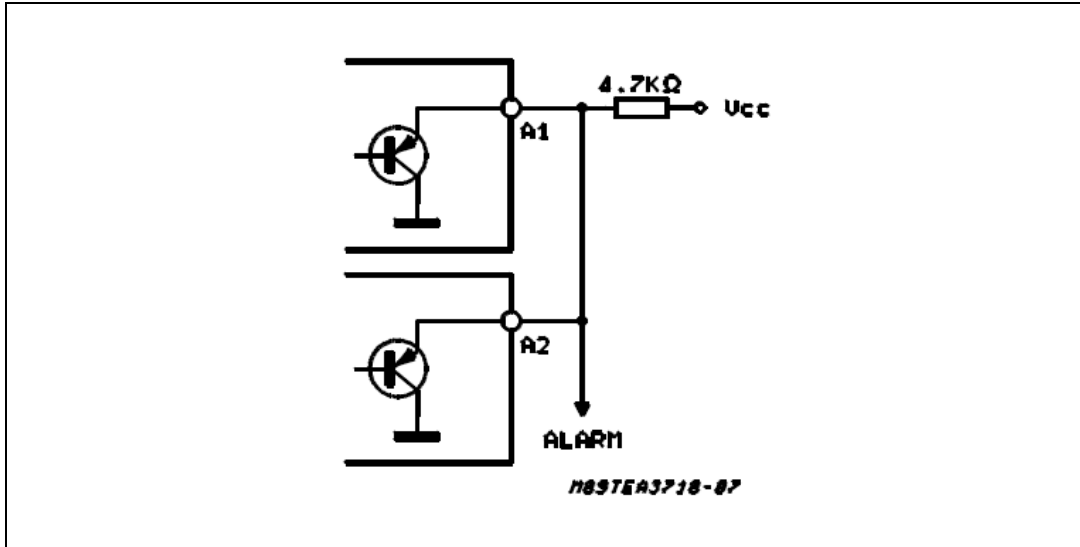

Figure 17. Common detection for several Multiwatt packages



#### 4.2 Pre-alarm output (TEA3718SFP)

When the junction temperature reaches  $T1^{\circ}\text{C}$  (typically =  $170^{\circ}\text{C}$ ) a pre-alarm signal is generated on the PRE-ALARM output pin.

Soft thermal protection occurs when function temperature reaches  $T2$  ( $T2 > T1$ ).

#### 4.3 Current reduction in alarm condition

Note: The resistance values given in this section are for the  $V_{CH}$  threshold. They should be adjusted when using other comparator thresholds or  $V_{ref}$  values.

Figure 18. Current reduction in the motor on alarm condition (typical curve)

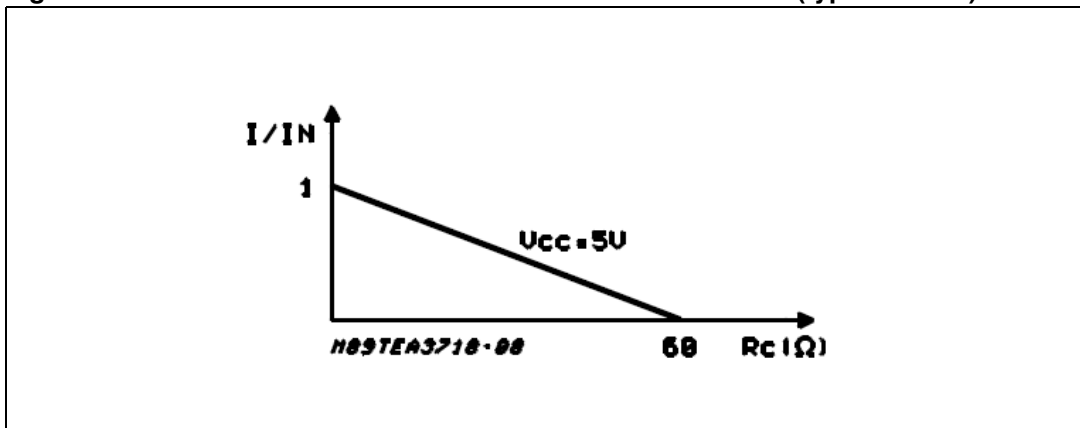
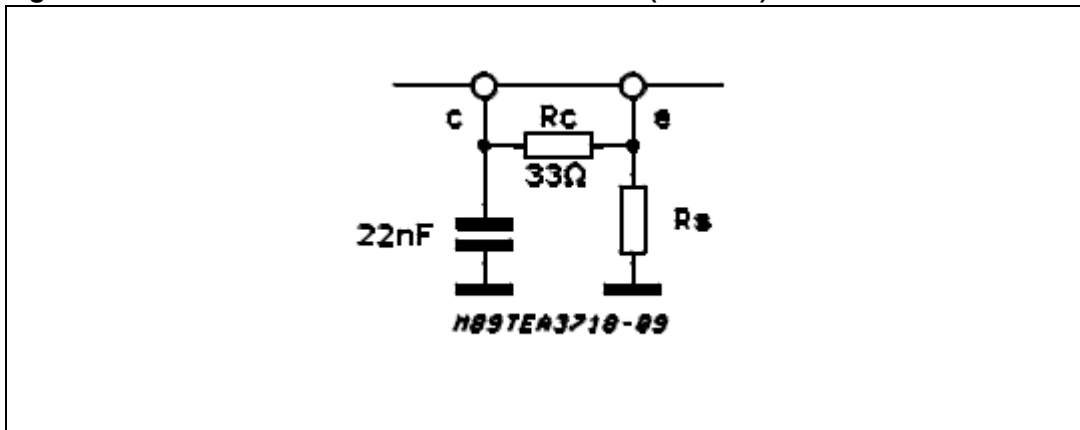
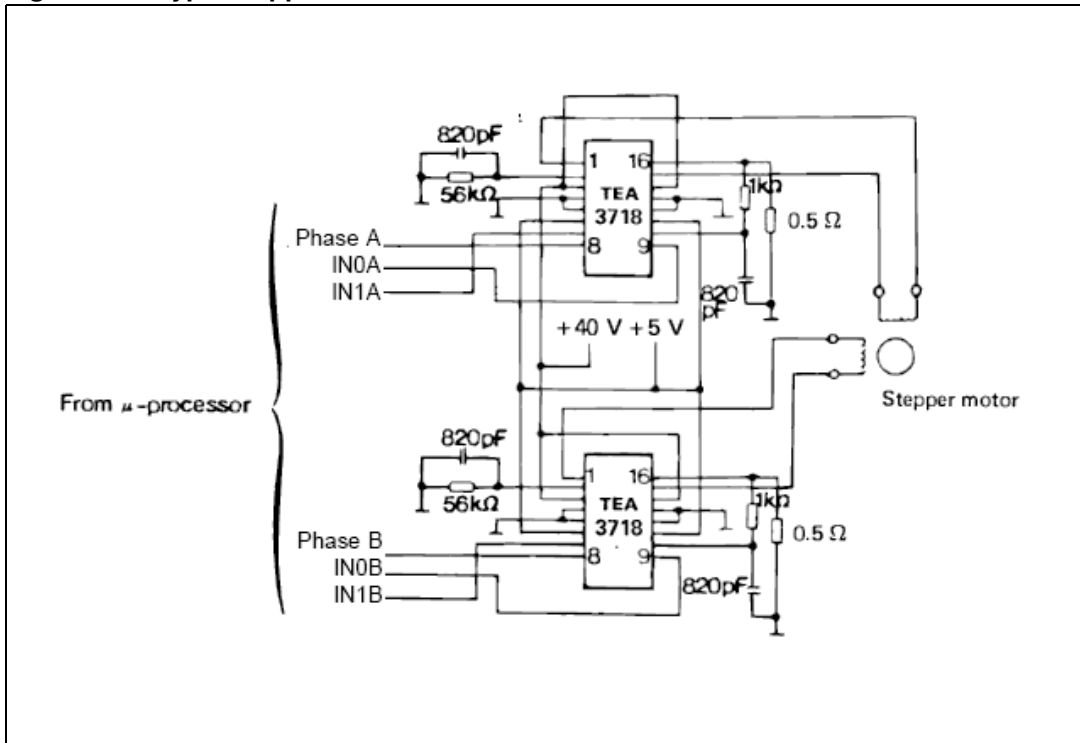

Figure 19. Half-current on alarm condition circuit ( $V_{ref} = 5\text{ V}$ )



#### 4.4 Typical application

Figure 20. Typical application circuit



## 5 Functional description

The circuit is intended to drive a bipolar constant current through one motor winding. The constant current is generated through switch mode regulation.

There is a choice of three different current levels with the two logic inputs IN0 and IN1. The current can also be switched off completely.

### 5.1 Input logic

If any logic input is left open, the circuit treats it as a high-level input.

**Table 8. Truth table**

IN0	IN1	Current level
H	H	No current
L	H	Low current
H	L	Medium current
L	L	Maximum current

### 5.2 Phase input

The PHASE input pin determines the direction of current flow in the winding, depending on the motor connections. The signal is fed through a Schmidt trigger for noise immunity, and through a time delay in order to guarantee that no short-circuit occurs in the output stage during phase-shift. A high level on the PHASE input causes the motor current flow from OUTA through the winding to OUTB.

The IH0 and IH1 input pins select the current level in the motor winding. The values of the different current levels are determined by the reference voltage VR together with the value of the sensing resistor  $R_S$ .

### 5.3 Current sensor

This part contains a current sensing resistor ( $R_S$ ), a low pass filter ( $R_C$ ,  $C_C$ ) and three comparators. Only one comparator is active at a time. It is activated by the input logic according to the current level chosen with signals IN0 and IN1. The motor current flows through the sensing resistor RS. When the current has increased so that the voltage across RS becomes higher than the reference voltage on the other comparator input, the comparator output goes high, which triggers the pulse generator and its output goes high during a fixed pulse time ( $t_{off}$ ), thus switching off the power feed to the motor winding, and causing the motor current to decrease during  $t_{off}$ .

### 5.4 Single-pulse generator

The pulse generator is a monostable triggered on the positive going edge of the comparator output. The monostable output is high during the pulse time,  $t_{off}$ , which is determined by the timing components  $R_T$  and  $C_T$ .  $t_{off} = 0.69 \cdot R_T \cdot C_T$

The single pulse switches off the power feed to the motor winding, causing the winding current to decrease during  $t_{off}$ . If a new trigger signal should occur during  $t_{off}$ , it is ignored.

### 5.5 Output stage

The output stage contains four Darlington transistors and four diodes, connected in an H-bridge. The two sinking transistors are used to switch the power supplied to the motor winding, thus driving a constant current through the winding.

*Note: It is not permitted to short circuit the outputs.*

### 5.6 $V_{SS}$ , $V_S$ and $V_R$

The circuit stands any order of turn-on or turn-off the supply voltages  $V_{SS}$  and  $V_S$ . Normal  $dV/dt$  values are then assumed.

Preferably,  $V_R$  should track  $V_{SS}$  during power on and power off if  $V_S$  is established.

### 5.7 Analog control

The current levels can be varied continuously if  $V_R$  is varied with a circuit varying the voltage on the comparator terminal.

**Figure 21. Power losses against output current**

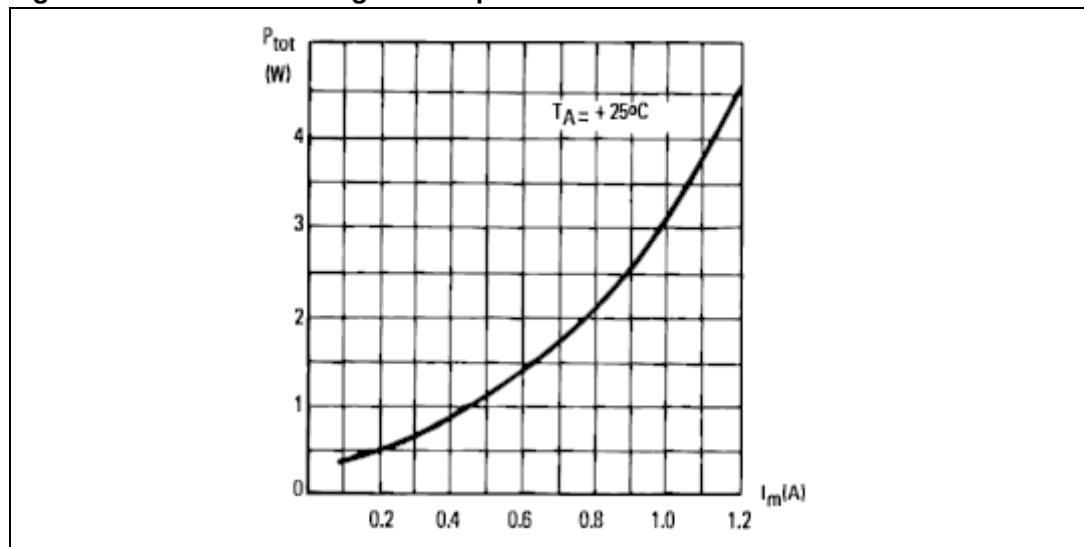

## 6 Application notes

### 6.1 Motor selection

Some stepper motors are not designed for continuous operation at maximum current. As the circuit drives a constant current through the motor, its temperature might increase excessively both at low and high speed operation.

Also, some stepper motors have such high core losses that they are not suited for switch mode current regulation.

### 6.2 Unused inputs

Unused inputs should be connected to proper voltage levels in order to get the highest noise immunity.

### 6.3 Interference

As the circuit operates with switch mode current regulation, interference generation problems might arise in some applications. A good measure might then be to decouple the circuit with a 15 nF ceramic capacitor, located near the package between power

line  $V_S$  and ground. The ground lead between  $R_S$ ,  $C_C$  and circuit GND should be kept as short as possible. This applies also to the lead between the sensing resistor  $R_S$  and point S. See [Section 4: Functional blocks](#).

## 6.4 Operating sequence

Figure 22. Principal operating sequence

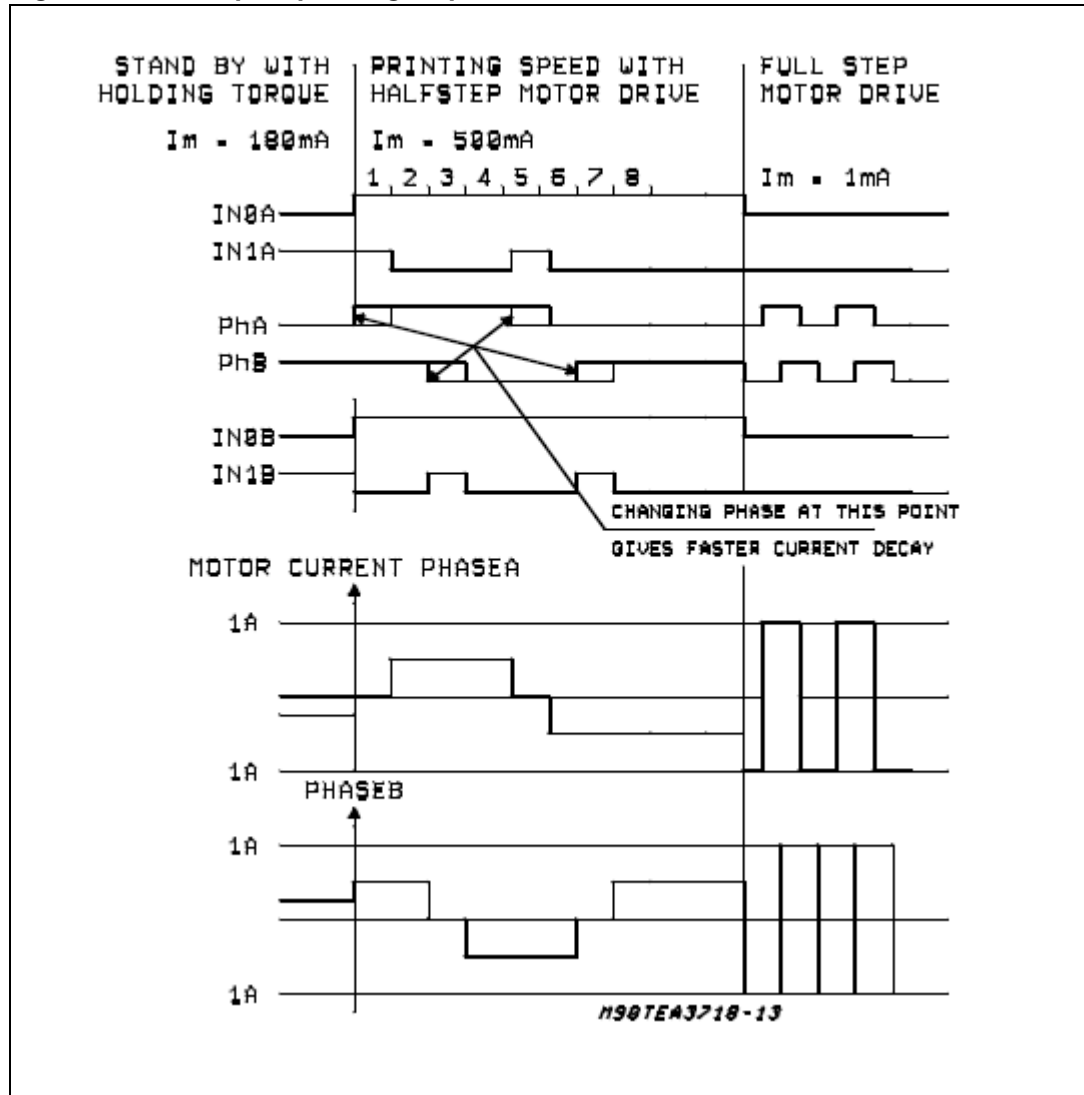

## 7 Package mechanical data

In order to meet environmental requirements, ST offers these devices in different grades of ECOPACK® packages, depending on their level of environmental compliance. ECOPACK® specifications, grade definitions and product status are available at: [www.st.com](http://www.st.com). ECOPACK® is an ST trademark.

Package mechanical data

DIM.	mm			inch		
	MIN.	TYP.	MAX.	MIN.	TYP.	MAX.
A			5			0.197
B			2.65			0.104
C			1.6			0.063
D		1			0.039	
E	0.49		0.55	0.019		0.022
F	0.66		0.75	0.026		0.030
G	1.02	1.27	1.52	0.040	0.050	0.060
G1	17.53	17.78	18.03	0.690	0.700	0.710
H1	19.6			0.772		
H2			20.2			0.795
L	21.9	22.2	22.5	0.862	0.874	0.886
L1	21.7	22.1	22.5	0.854	0.870	0.886
L2	17.65		18.1	0.695		0.713
L3	17.25	17.5	17.75	0.679	0.689	0.699
L4	10.3	10.7	10.9	0.406	0.421	0.429
L7	2.65		2.9	0.104		0.114
M	4.25	4.55	4.85	0.167	0.179	0.191
M1	4.63	5.08	5.53	0.182	0.200	0.218
S	1.9		2.6	0.075		0.102
S1	1.9		2.6	0.075		0.102
Dia1	3.65		3.85	0.144		0.152

**OUTLINE AND MECHANICAL DATA**

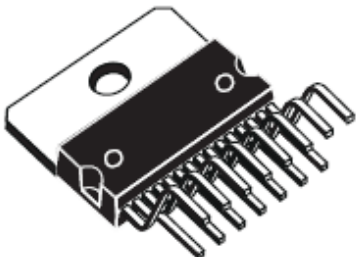

**Multiwatt15 V**

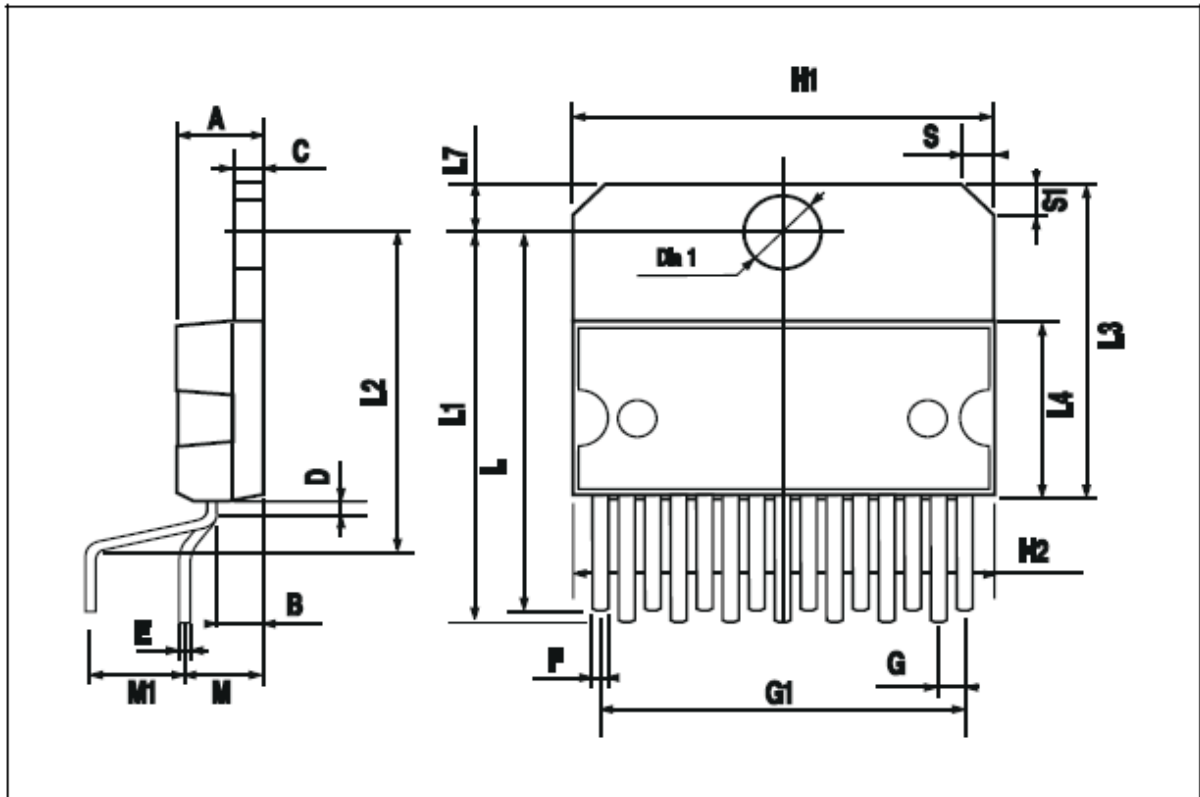

DIM.	mm			inch		
	MIN.	TYP.	MAX.	MIN.	TYP.	MAX.
a1	0.51			0.020		
B	0.85		1.40	0.033		0.055
b		0.50			0.020	
b1	0.38		0.50	0.015		0.020
D			20.0			0.787
E		8.80			0.346	
e		2.54			0.100	
e3		17.78			0.700	
F			7.10			0.280
I			5.10			0.201
L		3.30			0.130	
Z			1.27			0.050

OUTLINE AND MECHANICAL DATA

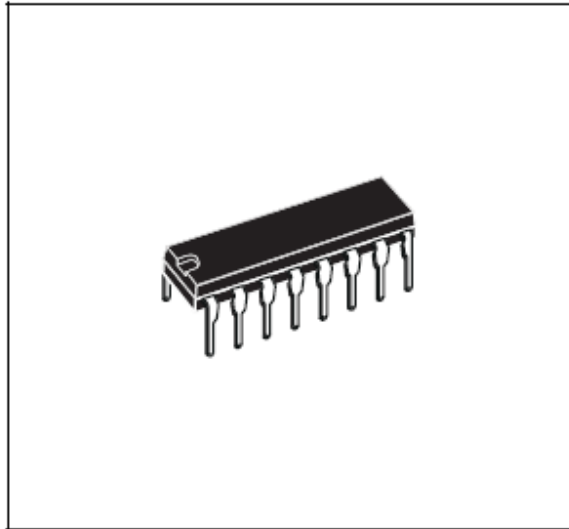

Powerdip 16

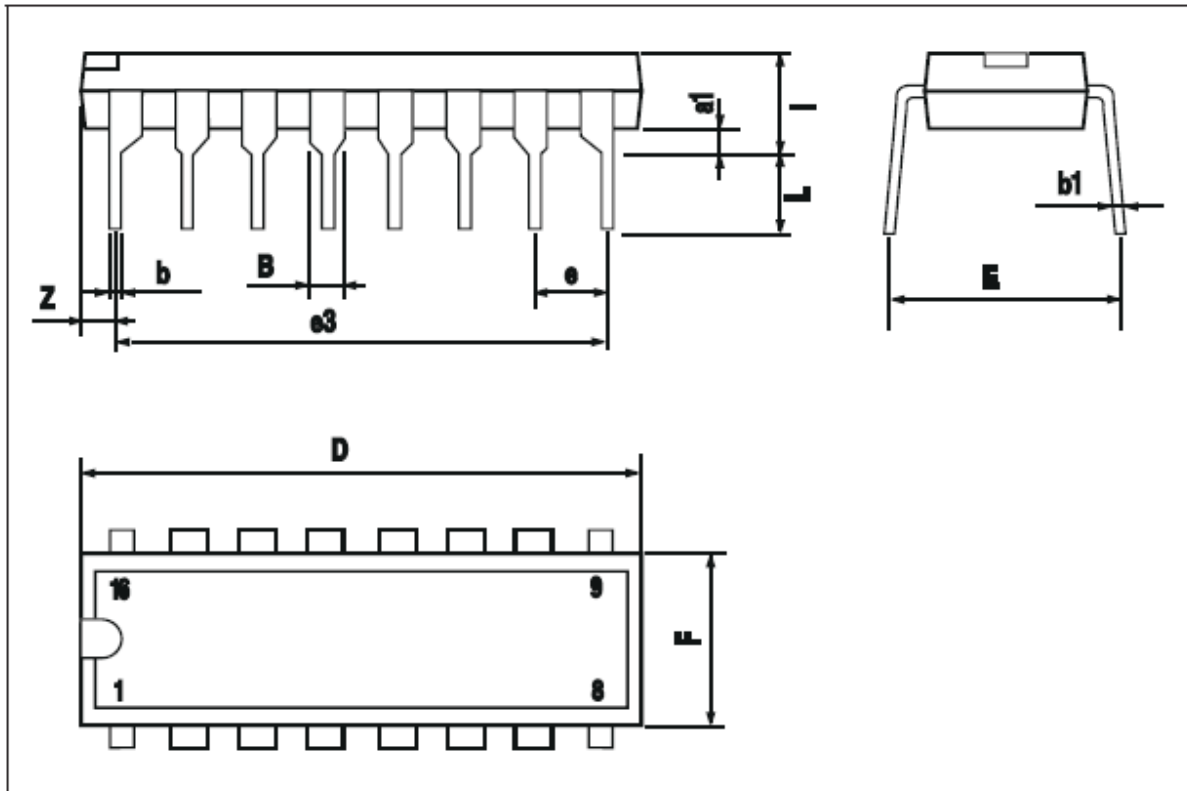

Package mechanical data

DIM.	mm			inch		
	MIN.	TYP.	MAX.	MIN.	TYP.	MAX.
A	2.35		2.65	0.093		0.104
A1	0.1		0.3	0.004		0.012
B	0.33		0.51	0.013		0.020
C	0.23		0.32	0.009		0.013
D	12.6		13	0.496		0.512
E	7.4		7.6	0.291		0.299
e		1.27			0.050	
H	10		10.65	0.394		0.419
h	0.25		0.75	0.010		0.030
L	0.4		1.27	0.016		0.050
K	0° (min.)8° (max.)					

OUTLINE AND MECHANICAL DATA

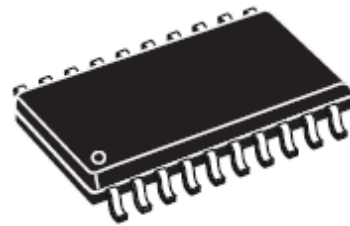

SO20

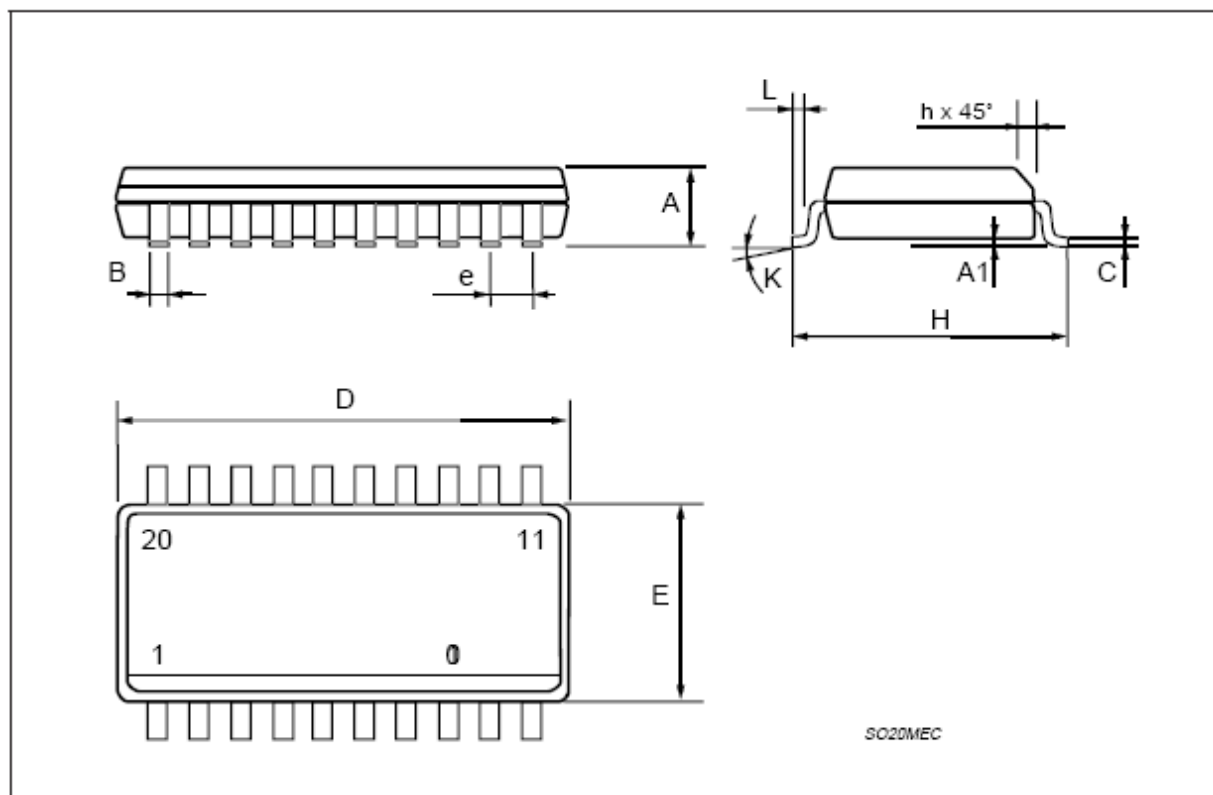

---

## Revision history

**Table 9. Document revision history**

Date	Revision	Changes
24-Jan-2006	1	Initial release.
21-Jan-2009	2	Document reformatted. Added <i>Figure 1</i> .

---

**Please Read Carefully:**

Information in this document is provided solely in connection with ST products. STMicroelectronics NV and its subsidiaries ("ST") reserve the right to make changes, corrections, modifications or improvements, to this document, and the products and services described herein at any time, without notice.

All ST products are sold pursuant to ST's terms and conditions of sale.

Purchasers are solely responsible for the choice, selection and use of the ST products and services described herein, and ST assumes no liability whatsoever relating to the choice, selection or use of the ST products and services described herein.

No license, express or implied, by estoppel or otherwise, to any intellectual property rights is granted under this document. If any part of this document refers to any third party products or services it shall not be deemed a license grant by ST for the use of such third party products or services, or any intellectual property contained therein or considered as a warranty covering the use in any manner whatsoever of such third party products or services or any intellectual property contained therein.

**UNLESS OTHERWISE SET FORTH IN ST'S TERMS AND CONDITIONS OF SALE ST DISCLAIMS ANY EXPRESS OR IMPLIED WARRANTY WITH RESPECT TO THE USE AND/OR SALE OF ST PRODUCTS INCLUDING WITHOUT LIMITATION IMPLIED WARRANTIES OF MERCHANTABILITY, FITNESS FOR A PARTICULAR PURPOSE (AND THEIR EQUIVALENTS UNDER THE LAWS OF ANY JURISDICTION), OR INFRINGEMENT OF ANY PATENT, COPYRIGHT OR OTHER INTELLECTUAL PROPERTY RIGHT.**

**UNLESS EXPRESSLY APPROVED IN WRITING BY AN AUTHORIZED ST REPRESENTATIVE, ST PRODUCTS ARE NOT RECOMMENDED, AUTHORIZED OR WARRANTED FOR USE IN MILITARY, AIR CRAFT, SPACE, LIFE SAVING, OR LIFE SUSTAINING APPLICATIONS, NOR IN PRODUCTS OR SYSTEMS WHERE FAILURE OR MALFUNCTION MAY RESULT IN PERSONAL INJURY, DEATH, OR SEVERE PROPERTY OR ENVIRONMENTAL DAMAGE. ST PRODUCTS WHICH ARE NOT SPECIFIED AS "AUTOMOTIVE GRADE" MAY ONLY BE USED IN AUTOMOTIVE APPLICATIONS AT USER'S OWN RISK.**

Resale of ST products with provisions different from the statements and/or technical features set forth in this document shall immediately void any warranty granted by ST for the ST product or service described herein and shall not create or extend in any manner whatsoever, any liability of ST.

ST and the ST logo are trademarks or registered trademarks of ST in various countries.

Information in this document supersedes and replaces all information previously supplied.

The ST logo is a registered trademark of STMicroelectronics. All other names are the property of their respective owners.

© 2009 STMicroelectronics - All rights reserved

STMicroelectronics group of companies

Australia - Belgium - Brazil - Canada - China - Czech Republic - Finland - France - Germany - Hong Kong - India - Israel - Italy - Japan - Malaysia - Malta - Morocco - Singapore - Spain - Sweden - Switzerland - United Kingdom - United States of America

[www.st.com](http://www.st.com)



## Looking for pricing, stock, or lifecycle information?

Click below to explore more details on WIN SOURCE:

 [View E-TEA3718SFP](#) on WIN SOURCE

 [STMicroelectronics](#) Information

## Optimize Your Supply Chain with WIN SOURCE Solutions

-  Global Sourcing Solution
-  Obsolete Management
-  Cost Control Management
-  Shortage Management
-  Alternative Solution
-  Excess Inventory Management