



【4. 性能 PERFORMANCE】

4 - 1. 電気的性能 Electrical Performance

項目 Item		条件 Test Condition	規格 Requirement
4-1-1	接触抵抗 Contact Resistance	適合FPCを嵌合させ、開放電圧20mV以下、短絡電流10mA以下にて測定する。 (JIS C5402 5.4) Mate applicable FPC, measured at the open circuit voltage 20mV MAXIMUM and short circuit 10mA MAXIMUM. (JIS C5402 5.4)	40 milliohms MAXIMUM.
4-1-2	絶縁抵抗 Insulation Resistance	適合FPCを嵌合させ、隣接するターミナル間及びターミナル、アース間に、DC 500Vを印加し測定する。 (JIS C5402 5.2/MIL-STD-202 試験法 302) Mate applicable FPC, measured by applying DC 500V between adjacent terminal or terminal and ground. (JIS C5402 5.2/MIL-STD-202, Method 302)	50 Megohms MINIMUM.
4-1-3	耐電圧 Dielectric Strength	適合FPCを嵌合させ、隣接するターミナル間及びターミナル、アース間に、AC500V(実効値)を1分間印加する。感度電流は、2mAとする。 (JIS C5402 5.1/MIL-STD-202 試験法 301) Mate applicable FPC, applying AC 500V (effective value) between adjacent terminal or terminal and ground. Induced current is 2mA. (JIS C5402 5.1/MIL-STD-202, Method 301)	異常なきこと No Breakdown

4 - 2. 機械的性能 Mechanical Performance

項目 Item		条件 Test Condition	規格 Requirement
4-2-1	FPC保持力 FPC Retention Force	適合FPCを嵌合し、アクチュエータを閉じた状態にてFPCを嵌合軸方向に対して真っ直ぐ引き抜く。 Mate applicable FPC, close actuator, and pull the FPC .	第 7 項 参 照 Refer to paragraph 7
4-2-2	端子保持力 Terminal/Housing Retention Force	ハウジングに装着された各端子を引き抜く。 Pull out the each terminal assembled in the housing.	0.25N {0.025kgf} MIN.
4-2-3	金具保持力 Fitting Nail/Housing Retention Force	ハウジングに装着された各金具を引き抜く。 Pull out the each fitting nail assembled in the housing.	1.0N {0.1kgf} MIN.

REVISE ON PC ONLY		TITLE 0.5mm PITCH FPC Conn F/F E/O (LOWER CONTACT) 製品仕様書
<b>A</b>	SEE SHEET 1 OF 16	
REV.	DESCRIPTION	THIS DOCUMENT CONTAINS INFORMATION THAT IS PROPRIETARY TO MOLEX INC. AND SHOULD NOT BE USED WITHOUT WRITTEN PERMISSION

DOCUMENT NUMBER  
**PS-51296-009**

FILE NAME  
PS51296009.docx

SHEET  
2 OF 16

4-3. その他 Environmental Performance and Others

項目 Item		条件 Test Condition	規格 Requirement	
4-3-1	アクチュエータ 繰り返し動作 Durability of Actuator Operation	無通電状態にて、1分間に10回以下の速さでFPCの挿入、アクチュエータの開閉、FPCの抜去の動作を10回繰り返す。  Insert FPC, close and open actuator, withdraw FPC to 10 cycles, at the speed rate of less than 10 cycles per minute in power-off state.	接触抵抗 Contact Resistance	60 milliohm MAXIMUM
4-3-2	温度上昇 Temperature Rise	適合するFPCを嵌合させ、最大許容電流を通電し、コネクタの温度上昇分を測定する。 (UL 498)  Mate applicable FPC, measure the temperature rise of contact when the maximum AC rated current is passed. (UL 498)	温度上昇 Temperature Rise	30 °C MAXIMUM
4-3-3	耐振動性 Vibration	DC1mA通電状態にて、嵌合軸を含む互いに垂直な3方向に掃引割合10~55~10Hz/分、全振幅1.5mmの振動を各2時間(計6時間)加える。 (JIS C 60068-2-6 /MIL-STD-202 試験法 201)  Mate applicable FPC, add to each 2 hours (total:6 hours), with ratio sweep 10-55-10 Hz per minute and total amplitude 1.5 mm vibration at 3 directions mutually vertical including fitting axis in DC 1 mA electricity state. (JIS C60068-2-6/MIL-STD-202, Method 201)	外観 Appearance	異状なきこと No Damage
			接触抵抗 Contact Resistance	60 milliohm MAXIMUM
			瞬断 Discontinuity	1.0 microsecond MAXIMUM
4-3-4	耐衝撃性 Shock	DC 1mA通電状態にて、嵌合軸を含む互いに垂直な6方向に、490m/s <sup>2</sup> {50G}の衝撃を作用時間11millisecondで各3回加える。 (JIS C60068-2-27 / MIL-STD-202試験法 213)  Mate applicable FPC, add to each 3 times with impact of 490m/s <sup>2</sup> on action time 11 milliseconds at 6 directions mutually vertical including fitting axis in DC 1 mA electricity state (JIS C60068-2-27 / MIL-STD-202Method 213)	外観 Appearance	異状なきこと No Damage
			瞬断 Discontinuity	1.0 microsecond MAXIMUM
			接触抵抗 Contact Resistance	60 milliohm MAXIMUM

REVISE ON PC ONLY

**A**

SEE SHEET 1 OF 16

TITLE

0.5mm PITCH FPC Conn F/F E/O  
(LOWER CONTACT)

製品仕様書

REV.

DESCRIPTION

THIS DOCUMENT CONTAINS INFORMATION THAT IS PROPRIETARY TO MOLEX INC. AND SHOULD NOT BE USED WITHOUT WRITTEN PERMISSION

DOCUMENT NUMBER  
**PS-51296-009**

FILE NAME

PS51296009.docx

SHEET

3 OF 16

項目 Item		条件 Test Condition	規格 Requirement	
4-3-5	耐熱性 Heat Resistance	適合FPCを勘合させ、85±2℃の雰囲気中に96時間放置する。試験後、評価前に1～2時間室温に放置する。 (JIS C60068-2-2/MIL-STD-202 試験法 108 )  Mate applicable FPC, exposing for 96 hours in the atmosphere of 85+/-2 degree C. After the test, allowed to stand at room temperature for 1 to 2 hours before checking functionality. (JIS C60068-2-2/MIL-STD-202 Method 108)	外観 Appearance	異状なきこと No Damage
			接触抵抗 Contact Resistance	60 milliohm MAXIMUM
4-3-6	耐寒性 Cold Resistance	適合FPCを勘合させ、-40±3℃の雰囲気中に96時間放置する。試験後、評価前に1～2時間室温に放置する。 (JIS C60068-2-1)  Mate applicable FPC, exposing for 96 hours in the atmosphere of -40+/-3 degree C. After the test, allowed to stand at room temperature for 1 to 2 hours before checking functionality. (JIS C60068-2-1)	外観 Appearance	異状なきこと No Damage
			接触抵抗 Contact Resistance	60 milliohm MAXIMUM
4-3-7	耐湿性 Humidity	適合FPCを嵌合させ、60±2℃ 相対湿度 90～95% の雰囲気中に 96時間 放置する。試験後、評価前に1～2時間 室温に放置する。 (JIS C60068-2-78/MIL-STD-202 試験方法103)  Mate applicable FPC, exposing for 96 hours in an atmosphere of 60+/-2 degree C, relative humidity 90 to 95%. After the test, allowed to stand at room temperature for 1 to 2 hours before checking functionality. (JIS C60068-2-78/MIL-STD-202 Method 103)	外観 Appearance	異状なきこと No Damage
			接触抵抗 Contact Resistance	60 milliohm MAXIMUM
			耐電圧 Dielectric Strength	4-1-3項 満足のこと Must meet 4-1-3
絶縁抵抗 Insulation Resistance	20 Megohms MINIMUM			
4-3-8	温度サイクル Temperature Cycling	適合するFPCを嵌合させ、-40±3℃に30分、+85±2℃に30分、これを1サイクルとし、5サイクル繰り返す。但し、温度移行時間は、5分以内とする。試験後1～2時間室温に放置する。 (JIS C60068-2-14)  Mate applicable FPC, exposing to 85+/-2 degree C and -40+/-3 degree C temperature extermis for 30 minutes each including a 0-5 minutes transition time. The above-mentioned condition is repeated 5 cycles. After the test, allowed to stand at the room temperature for 1 to 2 hours before checking functionality. (JIS C60068-2-14)	外観 Appearance	異状なきこと No Damage
			接触抵抗 Contact Resistance	60 milliohm MAXIMUM

REVISE ON PC ONLY

**A**

SEE SHEET 1 OF 16

TITLE

0.5mm PITCH FPC Conn F/F E/O  
(LOWER CONTACT)

製品仕様書

REV.

DESCRIPTION

THIS DOCUMENT CONTAINS INFORMATION THAT IS PROPRIETARY TO MOLEX INC. AND SHOULD NOT BE USED WITHOUT WRITTEN PERMISSION

DOCUMENT NUMBER  
**PS-51296-009**

FILE NAME

PS51296009.docx

SHEET

4 OF 16

# molex PRODUCT SPECIFICATION

LANGUAGE

JAPANESE  
ENGLISH

項目 Item		条件 Test Condition	規格 Requirement	
4-3-9	塩水噴霧 Salt Spray	<p>適合するFPCを嵌合させ、35±2℃にて、重量比5±1%の塩水を48時間噴霧し、試験後常温で水洗いした後、室温で乾燥させる。 (JIS C60068-2-11/MIL-STD-202 試験方法101)</p> <p>Mate applicable FPC, exposing to the atmosphere where salt mist is diffused in. Other condition is written below. NaCl solution : 5+/-1% by weight Temperature : 35+/-2 degree C Duration : 48 hours After the test, they should be washed well by water and dried at room temperature before checking functionality. (JIS C60068-2-11/MIL-STD-202 Method 101)</p>	外観 Appearance	異状なきこと No Damage
			接触抵抗 Contact Resistance	60 milliohm MAXIMUM
4-3-10	亜硫酸ガス SO <sub>2</sub> Gas	<p>適合するFPCを嵌合させ、40±2℃、25±5ppm、相対湿度75%R.H.の亜硫酸ガス中に96時間放置する。</p> <p>Mate applicable FPC, exposing to the atmosphere is written below. Gas Concentration : SO<sub>2</sub>=25+/-5ppm Temperature : 40+/-2 degree C Humidity : 75%R.H. Duration : 96hours</p>	外観 Appearance	異状なきこと No Damage
			接触抵抗 Contact Resistance	60 milliohm MAXIMUM
4-3-11	硫化水素ガス H <sub>2</sub> S Gas	<p>適合するFPCを嵌合させ、40±2℃、3±1ppm、相対湿度75%R.H.の硫化水素ガス中に96時間放置する。</p> <p>Mate applicable FPC, exposing to the atmosphere is written below. Gas Concentration : H<sub>2</sub>S=3+/-1ppm Temperature : 40+/-2 degree C Humidity : 75%R.H. Duration : 96hours</p>	外観 Appearance	異状なきこと No Damage
			接触抵抗 Contact Resistance	60 milliohm MAXIMUM
4-3-12	耐アンモニア性 NH <sub>3</sub> Gas	<p>適合するFPCを嵌合させ、濃度28%のアンモニア水から発生させたアンモニアガス中に40分間放置する。</p> <p>Mate applicable FPC, allow to stand for 40 minutes in a container filled with NH<sub>3</sub> gas(from density 28% ammonia water).</p>	外観 Appearance	異状なきこと No Damage
			接触抵抗 Contact Resistance	60 milliohm MAXIMUM

REVISE ON PC ONLY

**A**

SEE SHEET 1 OF 16

TITLE

0.5mm PITCH FPC Conn F/F E/O  
(LOWER CONTACT)

製品仕様書

REV.

DESCRIPTION

THIS DOCUMENT CONTAINS INFORMATION THAT IS PROPRIETARY TO MOLEX INC. AND SHOULD NOT BE USED WITHOUT WRITTEN PERMISSION

DOCUMENT NUMBER  
**PS-51296-009**

FILE NAME

PS51296009.docx

SHEET

5 OF 16

EN-037(2013-04 rev.1)

項目 Item		条件 Test Condition	規格 Requirement	
4-3-13	半田付け性 Solder Ability	端子先端より0.2mm、金具先端より0.2mmの位置まで、245±5℃の半田に3±0.5秒浸す。 Dip 0.2mm from the tip of the solder tails and 0.2mm from fitting nail into the molten solder which is held at 245 +/-5 degree C for 3+/-0.5 seconds.	濡れ性 Solder Wetting	浸漬面積の90%以上90% of immersed area must show no voids, pin holes.
4-3-14	半田耐熱性 Resistance to Soldering Heat	赤外線リフロー時 (Reflow by Infrared Reflow Machine) 第5項に示す推奨温度プロファイル条件にて、リフローを行う。 The product is reflowed using the reflow profile as shown paragraph 5.	外観 Appearance	異状無き事 No Damage
		手半田時 (Reflow by Manual Soldering iron) 端子先端、及び金具先端より0.2mmの位置まで、350±10℃の半田ゴテにて3±1秒加熱する。但し、異常な加圧のないこと。 Using a soldering iron (350+/-10 degrees C for 3+/-1 seconds)heat up the area 0.2mm from the tip of the solder tails and fitting nails. However, do not apply excessive pressure to either the terminals or fitting nails.		

( ) : 参考規格 Reference Standard

{ } : 参考単位 Reference Unit

\* 各項目の評価サンプルは、製品図面に記載されている推奨基板レイアウト、推奨メタルマスクにて実装しています。リフロー条件は4-3-14の推奨温度プロファイルにて実装しております。半田ペーストは、無鉛半田 (Sn-3Ag-0.5Cu) を使用しています。

The evaluation samples of each specification test are reflowed according to the recommended Print Circuit Board layout and the recommended metal mask thickness specified in the sales drawing. The reflow conditions followed are specified in the reflow profile in section 4-3-14. Lead free solder (Sn-3Ag-0.5Cu) was used as the soldering paste

A	REVISE ON PC ONLY	TITLE 0.5mm PITCH FPC Conn F/F E/O (LOWER CONTACT) 製品仕様書	
	SEE SHEET 1 OF 16		
REV.	DESCRIPTION	THIS DOCUMENT CONTAINS INFORMATION THAT IS PROPRIETARY TO MOLEX INC. AND SHOULD NOT BE USED WITHOUT WRITTEN PERMISSION	
DOCUMENT NUMBER PS-51296-009		FILE NAME PS51296009.docx	SHEET 6 OF 16
EN-037(2013-04 rev.1)			

【5. 赤外線リフロー条件 INFRARED REFLOW CONDITION】

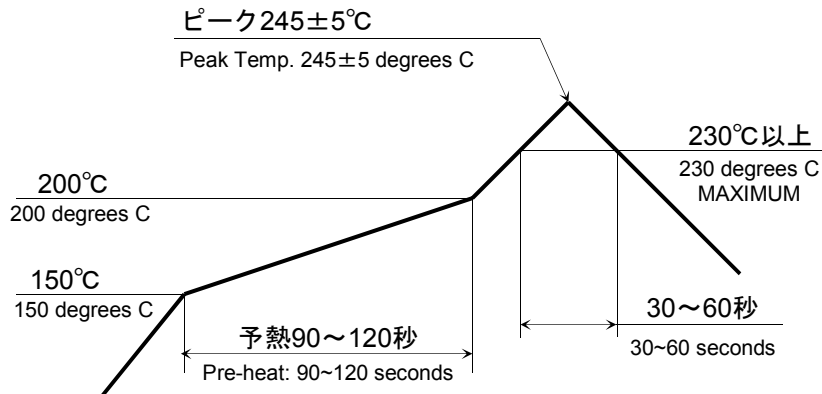

温度条件グラフ  
TEMPERATURE CONDITION GRAPH

半田接合部の基板表面にて測定

(Temperature is measured at the soldering area on the surface of the print circuit board)

注記：本リフロー条件に関しては、温度プロファイル、半田ペースト、大気、N<sub>2</sub>リフロー、基板などにより条件が異なりますので事前に実装評価(リフロー評価)を必ず実施願います。実装条件によっては、製品性能に影響を及ぼす場合があります。

NOTE: Please investigate the mounting condition (reflow soldering condition) on your own devices beforehand. The mounting conditions may change due to the soldering temperature, soldering paste, air reflow machine, Nitrogen reflow machine, and the type of printed circuit board. The different mounting conditions may have an influence on the product's performance.

【6. 外観形状、寸法及び材質 PRODUCT SHAPE, DIMENSIONS AND MATERIALS】

製品はELV及びRoHSを満たしております。 Product fulfills ELV and RoHS.

他の情報については図面を参照願います。 Refer to the drawing about any other information.

REVISE ON PC ONLY		TITLE	
<b>A</b>	SEE SHEET 1 OF 16	0.5mm PITCH FPC Conn F/F E/O (LOWER CONTACT)	
	REV.	DESCRIPTION	製品仕様書
		THIS DOCUMENT CONTAINS INFORMATION THAT IS PROPRIETARY TO MOLEX INC. AND SHOULD NOT BE USED WITHOUT WRITTEN PERMISSION	
DOCUMENT NUMBER <b>PS-51296-009</b>		FILE NAME PS51296009.docx	SHEET 7 OF 16
EN-037(2013-04 rev.1)			

**【7. FPC保持力 FPC RETENTION FORCE】**

下記に示した表は、0.3mm厚のFPCを使用したときのFPC保持力のデータを示しております。ただし、FPCの仕様がFPC保持力に影響を与えるため、下記に示したFPC保持力の仕様を満たさない場合があります。

Table shown below is a data of FPC retention force when using a thickness of 0.3mm FPC. But, there's a case which FPC retention force doesn't fulfill the data value shown below, because FPC specification affects the result of FPC retention force.

極数 No. of Ckt	単位 UNIT	保持力(最小値) Retention Force (MIN.)	
		初回 1st	10回 10th
8	N {kgf}	2.4 {0.24}	1.9 {0.19}
12	N {kgf}	3.6 {0.36}	3.1 {0.31}
14	N {kgf}	4.2 {0.42}	3.7 {0.37}
18	N {kgf}	5.4 {0.54}	4.9 {0.49}
34	N {kgf}	10.2 {1.02}	9.7 {0.97}
40	N {kgf}	12.0 {1.20}	11.5 {1.15}
45	N {kgf}	13.5 {1.35}	13.0 {1.30}
50	N {kgf}	14.0 {1.40}	13.5 {1.35}
60	N {kgf}	14.5 {1.45}	14.0 {1.40}

REVISE ON PC ONLY		TITLE	
<b>A</b>	SEE SHEET 1 OF 16	0.5mm PITCH FPC Conn F/F E/O (LOWER CONTACT)	
		製品仕様書	
REV.	DESCRIPTION	THIS DOCUMENT CONTAINS INFORMATION THAT IS PROPRIETARY TO MOLEX INC. AND SHOULD NOT BE USED WITHOUT WRITTEN PERMISSION	
DOCUMENT NUMBER <b>PS-51296-009</b>		FILE NAME PS51296009.docx	SHEET 8 OF 16
EN-037(2013-04 rev.1)			

**【8. 注意事項 NOTES】**

8-1 外観

8-1-1

本製品の樹脂部に黒点、ウエルド部の線、多少の傷が確認される事がありますが、製品性能には影響ございません。  
Although this product may have a small black mark, a weld line or a scratch on the housing, these will not have any influence on the product's performance.

8-1-2

本製品の端子、ネイルは錫系めっきを使用しているため、外観に摺動痕がつく場合が御座いますが、製品性能に影響はありません。

Because we plate the terminal and fitting nails with Tin, there may be scratch marks on the surface. However, these scratches will have no influence on the product's performance.

8-1-3

成形品の色相に多少の違いを生じる場合がありますが、製品性能には影響ありません。

There may be slight differences in the housing coloring, but there will be no influence on the product's performance.

8-1-4

紫外線によりアクチュエータが変色する場合がありますが、製品性能に影響ありません。

Although the ultraviolet light may potentially change the actuator color, this change has no on the product's performance.

8-2 実装

8-2-1

実装性能(平坦度)は、実装基板の反りの影響を含まないものと致します。基板の反りはコネクタ両端部を基準とし、コネクタ中央部にて Max0.02mmとして下さい。

The mounting specification for coplanarity does not include the influence of warpage of the printed circuit board. The warpage of the printed circuit board should be a maximum of 0.02mm if measuring from one connector edge to the other.

8-2-2

本製品の一般性能確認はリジッド基板にて実施おります。フレキシブル基板等の特殊な基板へ実装する場合は、事前に実装確認等を行った上でご使用願います。

The product performance was tested using rigid printed circuit board. In case the product needs to be reflowed onto flexible circuit board, please conduct a reflow test on the flexible circuit board in advance.

8-2-3

フレキシブル基板に実装する場合は、基板の変形を防止するため、補強板をご使用願います。

Please add a stiffener on the flexible printed circuit (FPC) when you mount the connector onto FPC in order to prevent deformation of the FPC.

8-2-4

リフロー条件によっては、樹脂部の変色や端子めっき部にヨリが発生する場合がありますが、製品性能に影響はございません。

Depending on the reflow conditions, there may be the possibility of a color change in the housing. However, this color change does not have any effect on the product's performance.

REVISE ON PC ONLY		TITLE	
<b>A</b>	SEE SHEET 1 OF 16	0.5mm PITCH FPC Conn F/F E/O (LOWER CONTACT) <b>製品仕様書</b>	
	REV.		
		THIS DOCUMENT CONTAINS INFORMATION THAT IS PROPRIETARY TO MOLEX INC. AND SHOULD NOT BE USED WITHOUT WRITTEN PERMISSION	
DOCUMENT NUMBER <b>PS-51296-009</b>		FILE NAME PS51296009.docx	SHEET 9 OF 16
EN-037(2013-04 rev.1)			

8-2-5

半田実装部の未半田は、ターミナル脱落、ピン間ショート、ターミナル座屈、またコネクタの基板からの外れが懸念されます。従って全てのターミナルテール部及び、ネイル部に半田付けを行って下さい。

If you leave any soldering area on this product open, there may be the possibility of a missing terminal short circuiting between pins, terminal buckling or the potential for the connector to come off of the printed circuit board. Therefore, please solder all of the terminals and fitting nails on the printed circuit board.

8-2-6

実装機によってコネクタに負荷が加わると変形、破損する場合がありますので事前にご確認下さい。

If there is accidental contact with the connector while it is going through the reflow machine, there may be deformation or damage caused to the connector. Please check to prevent this.

8-2-7

本製品のアクチュエータ材料は耐熱性ナイロンを使用しており、アクチュエータの吸水状態、或いは、はんだ付け条件によっては、リフローはんだ付け時にアクチュエータ表面に「ふくれ」が発生する可能性があります。この「ふくれ」に関しましては、ナイロン材の物性変化を伴うものではなく、製品機能を損なうものではありません。

The actuator material of this product is made from a high heat resistant Nylon. The soldering condition and the water absorption properties of the actuator material may cause blistering on the actuator surface.

Because this blister is not caused by property change, it does not damage the product's features.

8-3 製品の仕様について

8-3-1

コネクタの性能を損なう恐れがある為、コネクタの洗浄は、行わないで下さい。

Please do not conduct any "washing process" on the connector because it may damage the product's function.

8-3-2

適合するFPCの導体部は、錫系めっき(ニッケル下地)品を使用願います。

Please make sure to use the appropriate FPC which has Tin plating (Nickel under plating) on the contact area.

8-3-3

量産前にご使用になるFPCとの相性確認を行った上で、ご使用をお願い致します。

Please check the compatibility between the connector and the FPC prior to moving to mass production.

REVISE ON PC ONLY		TITLE	
<b>A</b>	SEE SHEET 1 OF 16	0.5mm PITCH FPC Conn F/F E/O (LOWER CONTACT) <b>製品仕様書</b>	
	REV.		
		THIS DOCUMENT CONTAINS INFORMATION THAT IS PROPRIETARY TO MOLEX INC. AND SHOULD NOT BE USED WITHOUT WRITTEN PERMISSION	
DOCUMENT NUMBER <b>PS-51296-009</b>		FILE NAME PS51296009.docx	SHEET 10 OF 16
EN-037(2013-04 rev.1)			

8-3-4

コネクタにFPCを装着した状態で、FPCに過度の負荷が加わらないようにご注意頂き、御社基板のスペース上、コネクタに負担の掛かる位置への取り付けはしないで下さい。コネクタのロックが解除されたり、FPCの抜け、断線、破損や接触不良の原因になります。特に、連続的に加わる場合はFPCを固定するようにして下さい。また、基板に対して垂直上下方向の引張荷重、コンタクトピッチ方向のこじり荷重を与えない様にご注意願います。

Please pay special attention not to have any pulling force/tension on the FPC when it is inserted into the connector. This can cause; the actuator to be unlocked, the actuator to come off, cut the traces on the FPC, and/or damage the FPC. Please be especially careful to avoid placing the FPC in a location where it will have a constant force applied on the FPC. If necessary, please fix the FPC directly on the chassis. Also, please avoid pulling the FPC vertically or twisting the FPC back and force horizontally while it is inserted in the connector.



図1-1  
Figure 1-1



図1-2  
Figure1-2

8-3-5

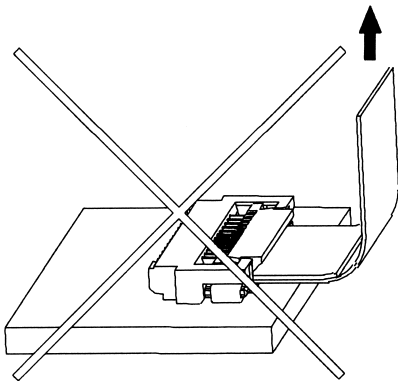
本製品をご使用時に取り付けられた電線・プリント基板の共振や、機器の回転構造や可動部分の動作によりコネクタ嵌合部(接点部)が常に動いてしまう状態での御使用は避けて下さい。接触部の摺動磨耗等による接触不良の原因となります。従って、機器内で電線・プリント基板を固定し、共振を抑える等の処置をお願い致します。

Please do not use the connector in a condition where the wire, the printed circuit board, or the contact area is experiencing a sympathetic vibration of wires and printed circuit board, and constant movement of devices. This may cause a defect in the contact due to the contact area being worn down. Therefore, please fix wires and printed circuit board on the chassis, and reduces sympathetic vibration.

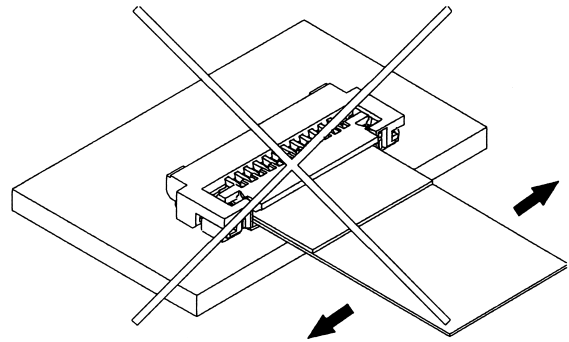
8-3-6

活電状態の電気回路で、挿入、抜去ができることを前提に作られていません。スパーク等による危険の発生、性能不良につながりますので、活電状態での挿入、抜去はしないで下さい。

This product is not designed for the mating and unmating of the connectors to be performed under the condition of an active electrical circuit. It may cause a spark and product defect if the connectors are mated and unmated in this way.

8-3-7

本製品の端子は錫メッキを使用しております。ご使用になるFPCとの相性確認としてウイスキー評価の実施を推奨いたします。

The terminals for this product are tin plated. We recommend that a Tin whiskering test is performed between your FPC and the connector beforehand to ensure that they are compatible.

REVISE ON PC ONLY		TITLE	
<b>A</b>	SEE SHEET 1 OF 16	0.5mm PITCH FPC Conn F/F E/O (LOWER CONTACT)	
		<b>製品仕様書</b>	
REV.	DESCRIPTION	THIS DOCUMENT CONTAINS INFORMATION THAT IS PROPRIETARY TO MOLEX INC. AND SHOULD NOT BE USED WITHOUT WRITTEN PERMISSION	
DOCUMENT NUMBER <b>PS-51296-009</b>		FILE NAME PS51296009.docx	SHEET 11 OF 16
EN-037(2013-04 rev.1)			

8-3-8

コネクタに外力が加わらないようにクリアランスをあげた筐体構造にしてください。

Please keep enough clearance between connector and chassis of your application in order not to apply pressure on the connector.

8-3-9

基板実装後に基板を直接積み重ねない様に注意してください。

Please do not stack the printed circuit board directly after mounted the connector on it.

8-4 製品操作

8-4-1

基板実装前後に端子、補強金具に触らないでください。

Please do not touch the terminals and fitting nails before or after reflowing the connector onto the printed circuit board.

8-4-2

FPC挿入する際は、アクチュエータが完全に開いた状態で行い、FPCがハウジングに突き当たるまで確実に挿入してください。左右斜めの状態で挿入すると、ピッチずれによるショート不良になったり、角がターミナルに引っ掛かりターミナルの変形やFPC導体めくれに至るケースがあります。

When inserting the FPC into the connector, please ensure that the actuator is completely open during insertion. Please also ensure that the FPC is completely inserted until the end of the FPC touches the housing. Diagonal insertion of the FPC into the connector can cause a short circuit due to the misaligned pitch. Diagonal insertion can also deform the terminal and/or damage the FPC contact area because the FPC edge may contact the terminal.

8-4-3

アクチュエータの開閉は、コネクタを基板に実装しFPCを挿入した状態で行ってください。FPCを挿入しない状態でのアクチュエータの開閉は、アクチュエータが外れる恐れがありますので行わないでください。

Please only open or close the actuator while the FPC is fully inserted. Please do not open and close the actuator without first inserting the FPC in the connector. This may damage the actuator.

8-4-4

アクチュエータ操作時にはピンセット等の先端が鋭利な物は使用しないでください。コネクタの破損、半田付け部の損傷の原因になります。

When opening and closing the actuator, please do not use a sharp edged tool such as tweezers. This may cause to damage the connector or to the soldering area.

REVISE ON PC ONLY		TITLE	
<b>A</b>	SEE SHEET 1 OF 16	0.5mm PITCH FPC Conn F/F E/O (LOWER CONTACT) <b>製品仕様書</b>	
	REV.		
		THIS DOCUMENT CONTAINS INFORMATION THAT IS PROPRIETARY TO MOLEX INC. AND SHOULD NOT BE USED WITHOUT WRITTEN PERMISSION	
DOCUMENT NUMBER <b>PS-51296-009</b>		FILE NAME PS51296009.docx	SHEET 12 OF 16
EN-037(2013-04 rev.1)			

8-4-5

アクチュエータを開閉する際は、左右均等に力が加わるように中央部を回転させて丁寧に操作するように、お願いします(図2-1参照)。荷重が一点に集中するような片側に偏った位置での操作は行わないで下さい(図2-2参照)。コネクタの破損の原因になります。

When opening and closing the actuator, please gently pull the center of the actuator by applying an even force across the actuator and rotating carefully. (See Figure 2-1) Please do not apply a force only to one side of actuator because it may cause to damage the connector. (See Figure 2-2)

**Good**

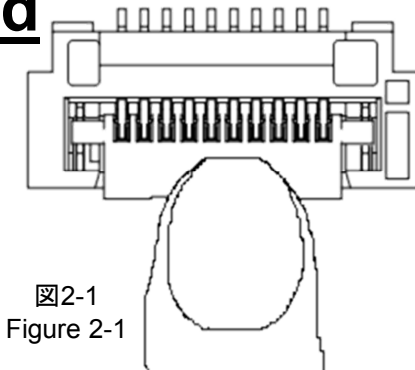

**No Good**

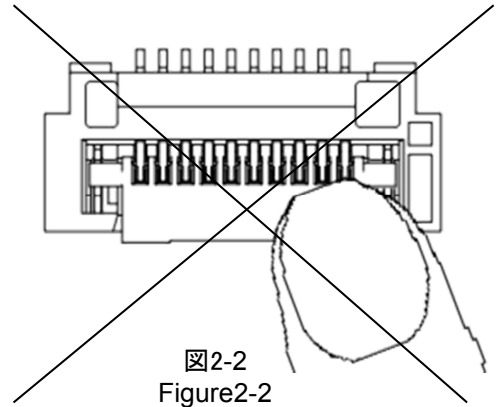

8-4-6

アクチュエータを閉じる際は、下図(図3)の様に回転する方向に軽く荷重が掛かる様に閉じて下さい。また、アクチュエータが外れる(押し出す)方向への荷重が加わらない様にご注意下さい。破損・外れの原因となります。

When closing the actuator, please press down on the actuator with soft pressure in the direction of the rotary axis as shown in the figure below, figure 3. Please do not push the actuator closed from the direction that the FPC is inserted. This may cause damage or disengagement of the actuator.

**Good**

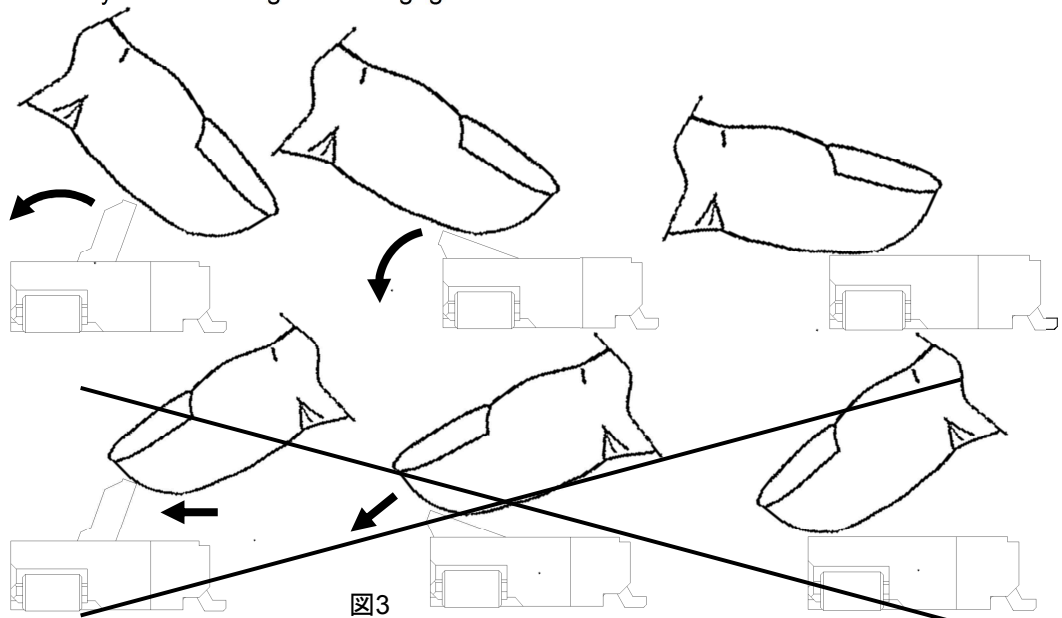

**No Good**

図3  
Figure 3

REVISE ON PC ONLY		TITLE	
<b>A</b>	SEE SHEET 1 OF 16	0.5mm PITCH FPC Conn F/F E/O (LOWER CONTACT)	
		<b>製品仕様書</b>	
REV.	DESCRIPTION	THIS DOCUMENT CONTAINS INFORMATION THAT IS PROPRIETARY TO MOLEX INC. AND SHOULD NOT BE USED WITHOUT WRITTEN PERMISSION	
DOCUMENT NUMBER <b>PS-51296-009</b>		FILE NAME PS51296009.docx	SHEET 13 OF 16
EN-037(2013-04 rev.1)			

8-4-7

アクチュエータを閉じた後は、下図のようにアクチュエータを確実にロックする為に表面を軽く押さえて下さい(図4参照)。  
After the actuator is closed, please apply soft pressure to ensure that the actuator is completely locked (as shown in figure below)(See Figure 4)



図4  
Figure4

8-4-8

アクチュエータのロックを解除する際は、アクチュエータに均等な力が加わるように、上方向へ押し上げて下さい。  
押し上げの際には、中央部を跳ね上げるように操作願います。アクチュエータが回転運動をして開きます。また、アクチュエータが変形及び破壊する方向（開く方向）への過大な負荷を掛けない様にご注意下さい。破損・外れの原因となります。  
When unlocking the actuator, please pull up on the center of actuator in the direction of actuator rotation, which delivers even force to both edges of actuator. Please do not apply any force in any other direction as this may deform or damage the actuator.

8-4-9

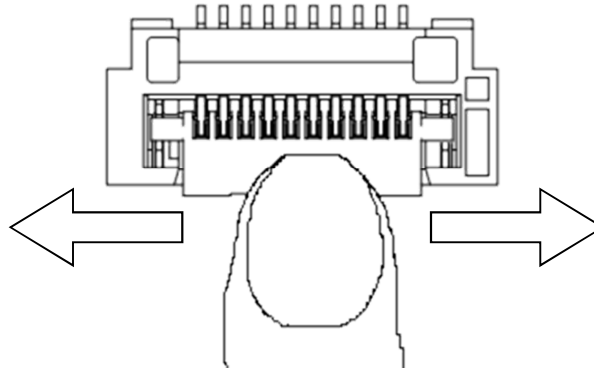
FPCを抜く時は、アクチュエータが完全に開いた状態で行って下さい。万が一、アクチュエータが完全に開いていない状態でFPCを抜いた時は、コンタクト部に付着物が無いか確認の上、再装着願います。  
When withdrawing the FPC, please make sure that the actuator is completely open. If the FPC is withdrawn without the actuator being fully open, please check to make sure that there is no debris on the contact area before inserting the FPC again.



図5  
Figure 5

8-4-10

嵌合後、コネクタピッチ方向への負荷がかかるような動作またはセットはしないでください。コネクタ破壊やはんだクラックを引き起こします。  
After mated the connector, please do not allow the printed circuit boards to apply pressure on the connector in either the pitch direction. It may cause damage to the connector and may crack the soldering.

REVISE ON PC ONLY		TITLE	
<b>A</b>	SEE SHEET 1 OF 16	0.5mm PITCH FPC Conn F/F E/O (LOWER CONTACT) <b>製品仕様書</b>	
	REV.		
DOCUMENT NUMBER <b>PS-51296-009</b>		FILE NAME PS51296009.docx	SHEET 14 OF 16
EN-037(2013-04 rev.1)			

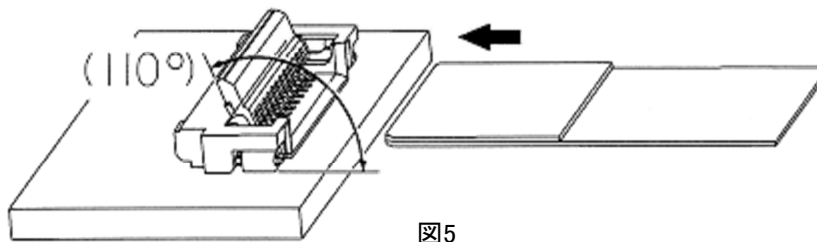
8-5 リペア

8-5-1

実装後において半田ゴテによる手修正を行う際は、必ず仕様書掲載の条件以内で行って下さい。条件を超えて実施した場合、端子の抜け、接点ギャップの変化、モールドの変形、溶融等、破損の原因になります。

When conducting manual repairs using a soldering iron, please follow the soldering conditions shown in the product specification. If the conditions in the product spec are not followed, it may cause the terminals to fall off, a change in the contact gap, a deformation of the housing, melting of the housing, and damage the connector.

8-5-2

半田ゴテによる手修正を行なう際、過度の半田やフラックスを使用しないで下さい。半田上がりやフラックス上がりにより接触、機能不良に至る場合があります。

When conducting manual repairs using a soldering iron, please do not use more solder and flux than needed. This may cause solder wicking and flux wicking issues, and it will eventually cause a contact defect and functional issues.

	REVISE ON PC ONLY		TITLE 0.5mm PITCH FPC Conn F/F E/O (LOWER CONTACT) 製品仕様書
	<b>A</b>	SEE SHEET 1 OF 16	
REV.	DESCRIPTION		THIS DOCUMENT CONTAINS INFORMATION THAT IS PROPRIETARY TO MOLEX INC. AND SHOULD NOT BE USED WITHOUT WRITTEN PERMISSION
DOCUMENT NUMBER <b>PS-51296-009</b>			FILE NAME PS51296009.docx
			SHEET 15 OF 16
EN-037(2013-04 rev.1)			



## Looking for pricing, stock, or lifecycle information?

Click below to explore more details on WIN SOURCE:

 [View 0512961233 on WIN SOURCE](#)

 [Molex, LLC Information](#)

## Optimize Your Supply Chain with WIN SOURCE Solutions

-  Global Sourcing Solution
-  Obsolete Management
-  Cost Control Management
-  Shortage Management
-  Alternative Solution
-  Excess Inventory Management