



THE DATASHEET OF PSP-600-48





■ Features :

- Universal AC input / Full range
- Built-in active PFC function
- Protections: Short circuit / Overload / Over voltage / Over temperature
- Forced air cooling by built-in DC fan
- With DC OK Signal output
- Current sharing up to 2400W(3+1)
- Built-in remote ON-OFF control
- Built-in remote sense function
- Fixed switching frequency at PFC:88KHz PWM:100KHz
- Operating altitude up to 3000 meters (Note.6)
- 3 years warranty



■ GTIN CODE

MW Search: <https://www.meanwell.com/serviceGTIN.aspx>



SPECIFICATION

MODEL	PSP-600-5	PSP-600-12	PSP-600-13.5	PSP-600-15	PSP-600-24	PSP-600-27	PSP-600-48	
OUTPUT	DC VOLTAGE	5V	12V	13.5V	15V	24V	27V	48V
	RATED CURRENT	80A	50A	44.5A	40A	25A	22.2A	12.5A
	CURRENT RANGE	0 ~ 80A	0 ~ 50A	0 ~ 44.5A	0 ~ 40A	0 ~ 25A	0 ~ 22.2A	0 ~ 12.5A
	RATED POWER	400W	600W	600.75W	600W	600W	599.4W	600W
	RIPPLE & NOISE (max.) Note.2	180mVp-p	240mVp-p	240mVp-p	240mVp-p	240mVp-p	240mVp-p	300mVp-p
	VOLTAGE ADJ. RANGE	4.75 ~ 5.5V	10 ~ 13.2V	12 ~ 15V	13.5 ~ 18V	20 ~ 26.4V	24 ~ 30V	41 ~ 56V
	VOLTAGE TOLERANCE Note.3	±2.0%	±1.0%	±1.0%	±1.0%	±1.0%	±1.0%	±1.0%
	LINE REGULATION	±0.5%	±0.5%	±0.5%	±0.5%	±0.5%	±0.5%	±0.5%
	LOAD REGULATION	±1.0%	±0.5%	±0.5%	±0.5%	±0.5%	±0.5%	±0.5%
	SETUP, RISE TIME	1500ms, 50ms at full load						
HOLD UP TIME (Typ.)	20ms at full load							
INPUT	VOLTAGE RANGE Note.5	88 ~ 264VAC	124 ~ 370VDC					
	FREQUENCY RANGE	47 ~ 63Hz						
	POWER FACTOR (Typ.)	0.95/230VAC	0.99/115VAC at full load					
	EFFICIENCY(Typ.)	79%	84%	85%	85%	86%	86%	87%
	AC CURRENT (Typ.)	6.8A/115VAC	3.4A/230VAC					
	INRUSH CURRENT (Typ.)	20A/115VAC	40A/230VAC					
LEAKAGE CURRENT	<1.3mA/240VAC							
PROTECTION	OVERLOAD	105 ~ 135% rated output power Protection type : Constant current limiting, recovers automatically after fault condition is removed						
	OVER VOLTAGE	5.75 ~ 6.75V	13.8 ~ 16.2V	15.5 ~ 18.2V	18 ~ 21V	27.6 ~ 32.4V	31 ~ 36.5V	57.6 ~ 67.2V
	OVER TEMPERATURE	Shut down o/p voltage, re-power on to recover						
FUNCTION	REMOTE CONTROL	RC+/RC-: Short = power on ; Open = power off						
	POK SIGNAL	PSU turn on: 3.3V ~ 5.6V PSU turn off: 0V ~ 1V						
ENVIRONMENT	WORKING TEMP.	-20 ~ +60°C (Refer to "Derating Curve")						
	WORKING HUMIDITY	20 ~ 90% RH non-condensing						
	STORAGE TEMP., HUMIDITY	-40 ~ +85°C, 10 ~ 95% RH non-condensing						
	TEMP. COEFFICIENT	±0.03%/°C (0 ~ 50°C)						
SAFETY & EMC (Note 4)	VIBRATION	10 ~ 500Hz, 2G 10min./1cycle, period for 60min. each along X, Y, Z axes						
	SAFETY STANDARDS	UL62368-1, TUV BS EN/EN62368-1, CCC GB4943.1, BSMI CNS15598-1, AS/NZS62368.1, EAC TP TC 004 approved						
	WITHSTAND VOLTAGE	I/P-O/P:3KVAC I/P-FG:2KVAC O/P-FG:0.5KVAC						
	ISOLATION RESISTANCE	I/P-O/P, I/P-FG, O/P-FG:100M Ohms / 500VDC / 25°C / 70% RH						
	EMC EMISSION	Compliance to BS EN/EN55032 (CISPR32) Class B, BS EN/EN61000-3-2,-3, GB9245, GB17625.1, BSMI CNS15936, EAC TP TC 020						
OTHERS	EMC IMMUNITY	Compliance to BS EN/EN61000-4-2,3,4,5,6,8,11, BS EN/EN55035, light industry level, EAC TP TC 020						
	MTBF	1132.9K hrs min. Telcordia SR-332 (Bellcore) ; 142.2K hrs min. MIL-HDBK-217F (25°C)						
	DIMENSION	170*120*93mm (L*W*H)						
NOTE	PACKING 1.9Kg; 8pcs/15.5Kg/1.00CUFT							
NOTE	<p>1. All parameters NOT specially mentioned are measured at 230VAC input, rated load and 25°C of ambient temperature.</p> <p>2. Ripple & noise are measured at 20MHz of bandwidth by using a 12" twisted pair-wire terminated with a 0.1uf & 47uf parallel capacitor.</p> <p>3. Tolerance : includes set up tolerance, line regulation and load regulation.</p> <p>4. The power supply is considered a component which will be installed into a final equipment. All the EMC tests are been executed by mounting the unit on a 360mm*360mm metal plate with 1mm of thickness. The final equipment must be re-confirmed that it still meets EMC directives. For guidance on how to perform these EMC tests, please refer to "EMI testing of component power supplies." (as available on https://www.meanwell.com/Upload/PDF/EMI_statement_en.pdf)</p> <p>5. Derating may be needed under low input voltages. Please check the derating curve for more details.</p> <p>6. The operating altitude is 2000 meters for CCC, 3000 meters for UL,TUV. The ambient temperature derating of 5°C/1000m is needed for operating altitude greater than 2000m (6500ft).</p> <p>※ Product Liability Disclaimer : For detailed information, please refer to https://www.meanwell.com/serviceDisclaimer.aspx</p>							

Mechanical Specification

(Unit: mm, tolerance $\pm 0.5\text{mm}$)

RS Connector(CN5) : JST B-XH or equivalent

Pin No.	Assignment	Mating Housing	Terminal
1	RS+	JST XHP or equivalent	JST SXH-001T or equivalent
2	RS-		

Terminal Pin No. Assignment

Pin No.	Assignment
1	AC/L
2	AC/N
3	FG \perp
4	P(Current Share)
5	POK
6	R.C.G
7	R.C.
8~11	DC OUTPUT +V
12~15	DC OUTPUT -V

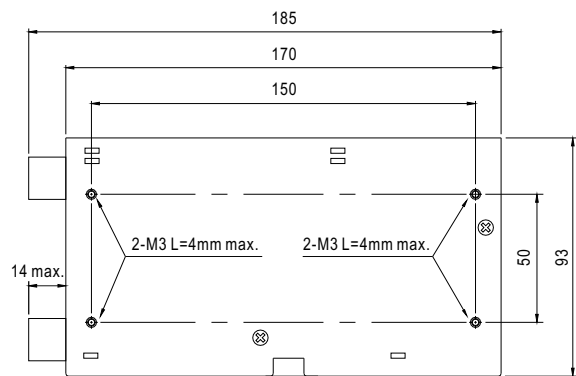
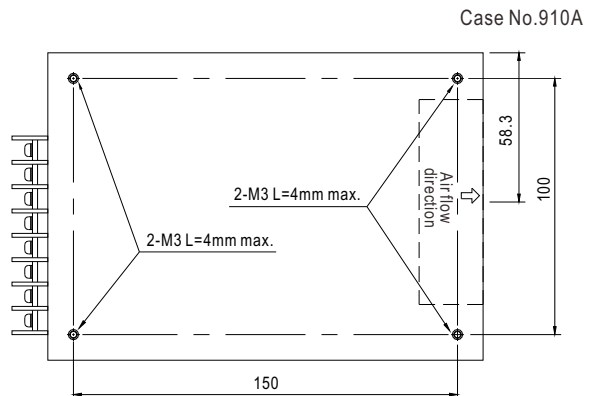
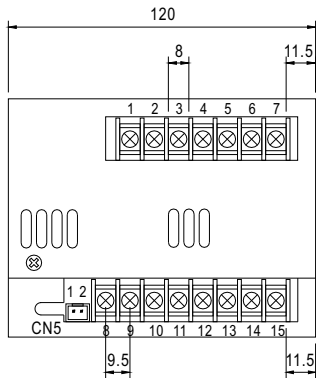

Case No.910A

Block Diagram

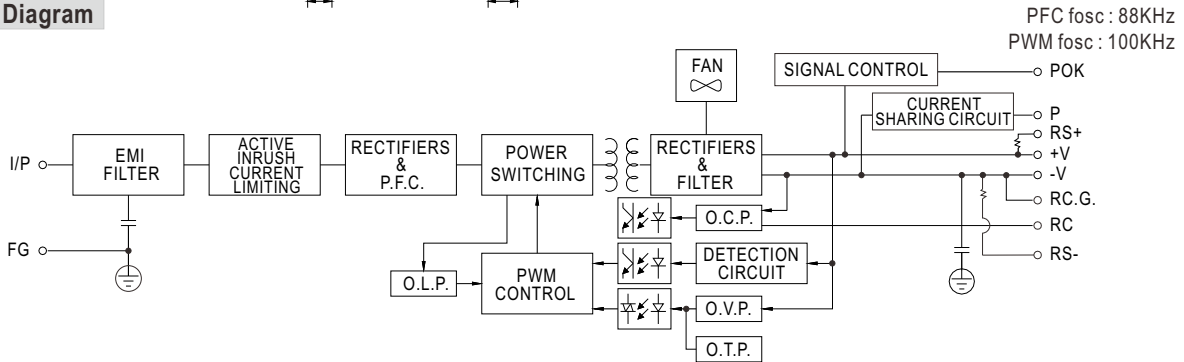

Derating Curve

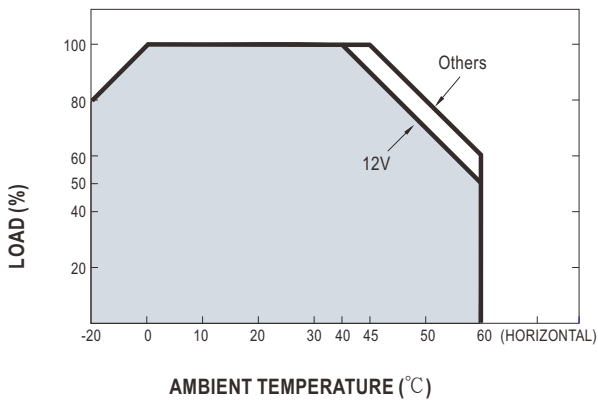

Output Derating VS Input Voltage

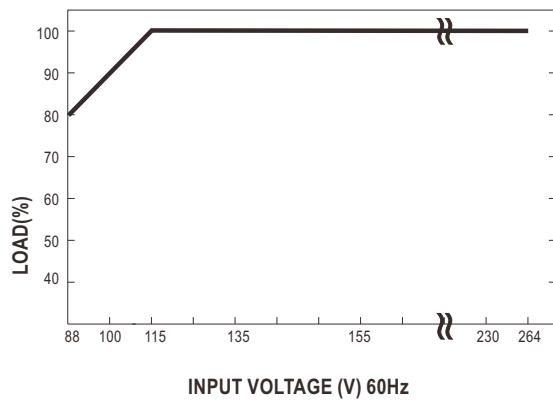

Control Terminal Instruction Manual

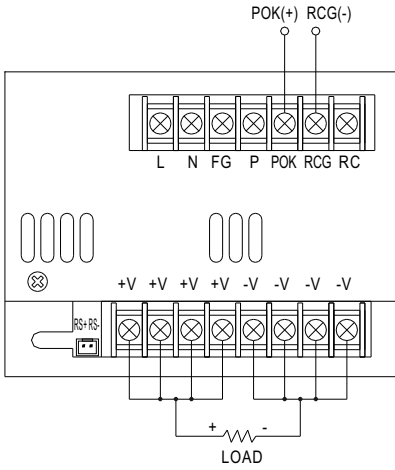

POK Signal

POK Signal is the voltage difference between "RCG" and "POK" pin output POK Signal for TTL level signal
 PSU turn on: 3.3V ~ 5.6V
 PSU turn off: 0V ~ 1V

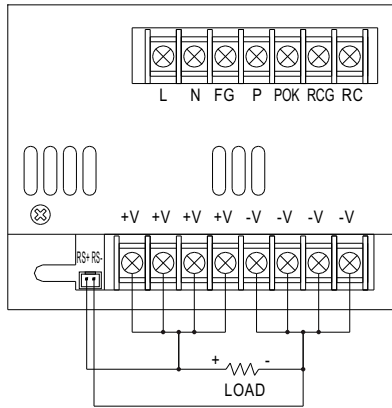

Remote Sensing

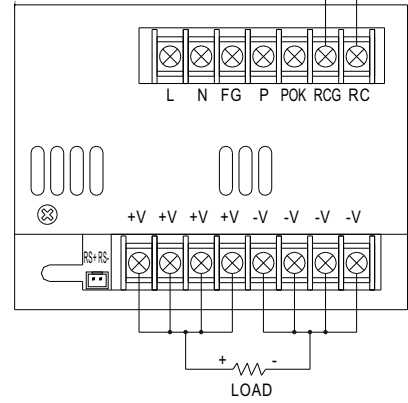

Remote Control

Power ON: RCG and RC for short
 Power OFF: RCG and RC for open

Parallel Operation with Remote Sensing

- (1) Parallel operation is available by connecting the units shown as below (+S, -S and P are connected mutually in parallel) :
- (2) The voltage difference among each output should be minimized that less than 0.2V is required.
- (3) The total output current must not exceed the value determined by the following equation (Output current at parallel operation)
 = (The rated current per unit) x (Number of unit) x 0.9.
- (4) In parallel operation 4 units is the maximum, please consult the manufacture for other applications.
- (5) When remote sensing is used in parallel operation, the sensing wire must be connected only to the master unit.
- (6) When in parallel operation, the minimum output load should be greater than 3% of total output load.
 (Min. load > 3% rated current per unit x number of unit)

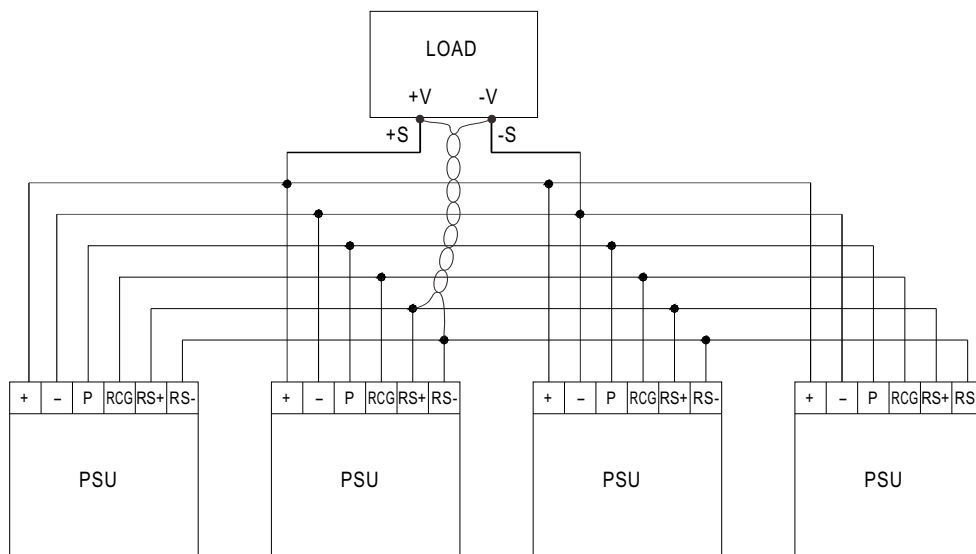

Looking for pricing, stock, or lifecycle information?

Click below to explore more details on WIN SOURCE:

- [View PSP-600-48 on WIN SOURCE](#)
- [Mean Well Enterprises Co., Ltd. Information](#)

Optimize Your Supply Chain with WIN SOURCE Solutions

- ✓ Global Sourcing Solution
- ✓ Obsolete Management
- ✓ Cost Control Management
- ✓ Shortage Management
- ✓ Alternative Solution
- ✓ Excess Inventory Management