

◆ Product Description

The GH1120 is a Hall-effect latch designed in CMOS technology. The IC internally includes a voltage regulator, Hall sensor with dynamic offset cancellation system, Schmitt trigger and an open-drain output driver. With no magnetic field present, the output is in the “on” state(Low). While the magnetic flux density(B) is larger than operate point(Bop),the output will be turned off(High) and the output is latched “off” state until the magnetic flux density (B) is lower than release point(Brp),then turn on(Low). It has wide operating voltage range and extended choice of temperature range, it is quite suitable for use in automotive, industrial and consumer applications.

◆ Features

- 3.5V to 24V DC Operation Voltage
- CMOS Technology
- Chopper-stabilized amplifier stage
- 25mA Output Sink Current
- Operating Temperature: -40~ +125°C
- High Magnetic Sensitivity: B_{hys}=60Gauss(Typ.)
- Lead Free Package: SIP-3L and SC59
(Commonly known as TO-92S and SOT-23-3L in Asia)
- Lead Free Finish/RoHS Compliant

◆ Application

- Rotor Position Sensing
- Current Switch
- Encoder
- RPM Detection

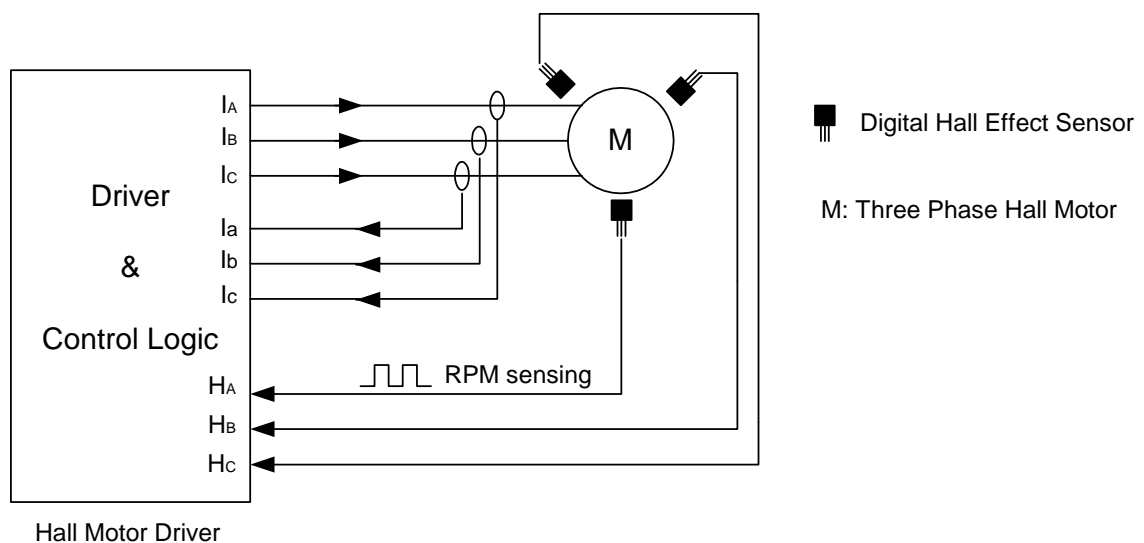

Fig.1 Functional Application Circuit in 3-Phase Hall Motor

◆ Pin Description

Table 1-1 Pin definition and description for SIP-3L(TO-92S)

| PIN # | NAME | P/I/O | FUNCTION DESCRIPTION |
|-------|------|-------|----------------------------|
| 1 | VDD | P | Input Power Supply |
| 2 | GND | P | Ground |
| 3 | OUT | O | Output Stage of Open Drain |

Table 1-2 Pin definition and description for SC59(SOT-23-3L)

| PIN # | NAME | P/I/O | FUNCTION DESCRIPTION |
|-------|------|-------|----------------------------|
| 1 | VDD | P | Input Power Supply |
| 2 | OUT | O | Output Stage of Open Drain |
| 3 | GND | P | Ground |

◆ Pin Configuration

(Top View)

UA:SIP-3L(TO-92S)

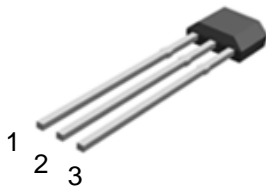

SW:SOT-23-3L

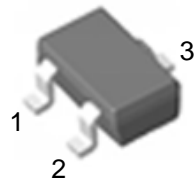

SE:SOT23

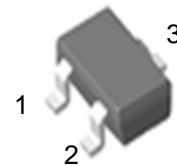

◆ **Absolute Maximum Rating** (Note 1)

| SYMBOL | PARAMETER | RATING |
|------------|--------------------------------------|--|
| VDD | Supply Voltage | +28VDC |
| Vout (off) | Voltage externally applied to output | +28VDC max, OFF condition only -0.5 V min., OFF or ON condition |
| Io (sink) | Output "ON" Current | 50 mA |
| PD | Power Dissipation | 450mW(SIP-3L);230mW(SC59) |
| Top | Operation Temperature Range | -40 to +125 °C |
| Tst | Storage Temperature Range | -65 to +150 °C |
| B | Magnetic Flux | No limit. |

Note 1: Absolute Maximum Ratings are those values beyond which the life of a device may be impaired.

◆ **Electrical Characteristics** (TA = 25°C)

| SYMBOL | PARAMETER | CONDITIONS | MIN | TYP | MAX | UNIT |
|-----------------|--|-----------------------------------|------------------|-----|------|------|
| VDD | Supply Voltage | Operating | 3.5 | | 24 | V |
| VO(SAT) | Output Saturation Voltage | VDD = 12V, OUT "ON", Io = 10mA | | | 300 | mV |
| | | VDD = 12V, OUT "ON", Io = 20mA | | | 500 | mV |
| IDD | Supply Current | VDD =3.5~24V, OUT "OFF" | | 2.0 | 5.0 | mA |
| ILE | Output Leakage Current (Leakage into sensor output) | Released | | | 10 | μA |
| Tr | Output Switching Time | Rise Time | RL=820Ω, CL=20pF | | 0.45 | μS |
| | | Fall Time | RL=820Ω, CL=20pF | | 0.45 | μS |
| F _{SW} | Maximum Switching Frequency | | | 10 | | KHz |

◆ **Magnetic Characteristics** (TA = 25°C, VDD=12V)

| SYMBOL | PARAMETER | MIN. | TYP. | MAX. | UNIT |
|--------|-----------------|------|------|------|-------|
| Bop | Operation Point | 5 | 30 | 80 | Gauss |
| Brp | Release Point | -80 | -30 | -5 | Gauss |
| Bhy | Hysteresis | 30 | 60 | 90 | Gauss |

◆ Functional Block Diagram

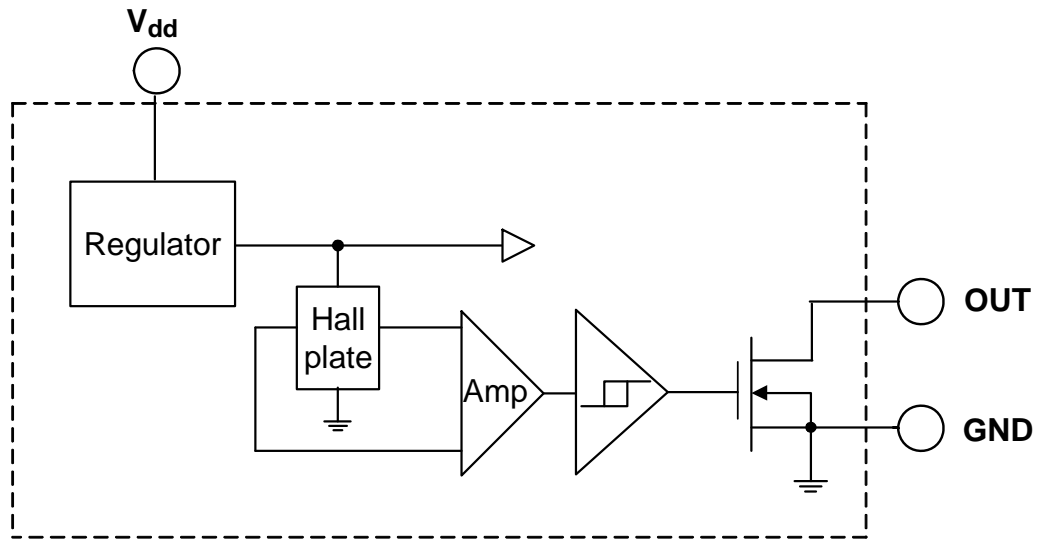

Figure 1. Function Block Diagram of GH1120

◆ Operating Characteristics

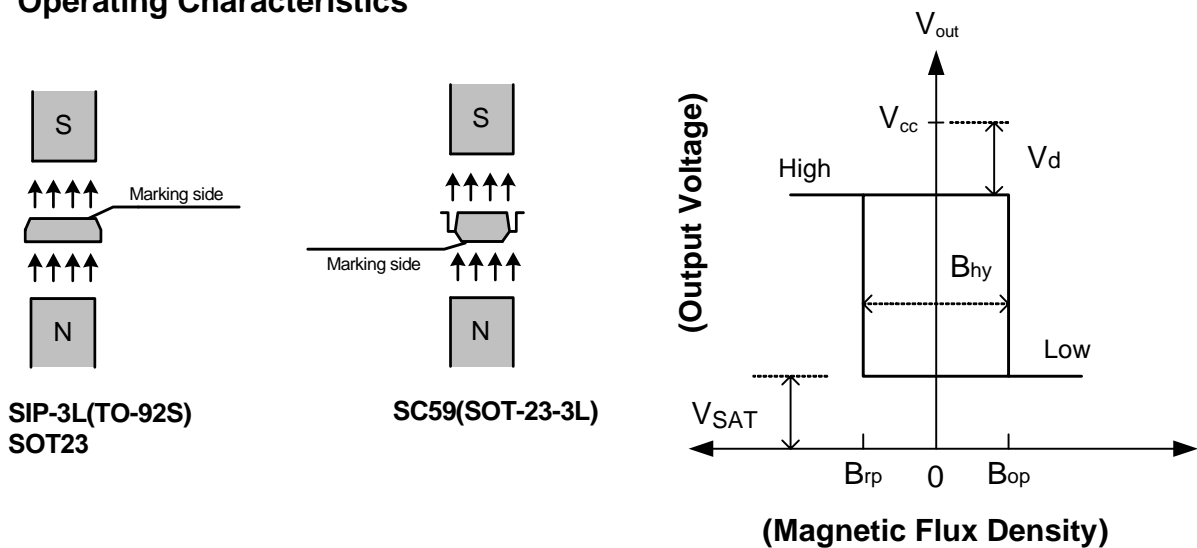

Figure 2. Operating Characteristics of GH1120

Table 2: Switching Function

| Parameter | Pole | OUT | Pole | OUT |
|------------|------------------|------|-----------------|------|
| | (SC59/SOT-23-3L) | | (SIP-3L/TO-92S) | |
| South Pole | $B < B_{RP}$ | High | $B > B_{OP}$ | Low |
| North Pole | $B > B_{OP}$ | Low | $B < B_{RP}$ | High |

◆ Typical Characteristics

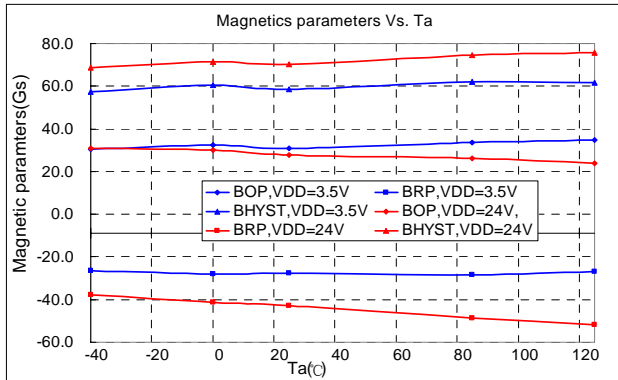

Figure 3-1. Magnetic parameters Vs. Ta

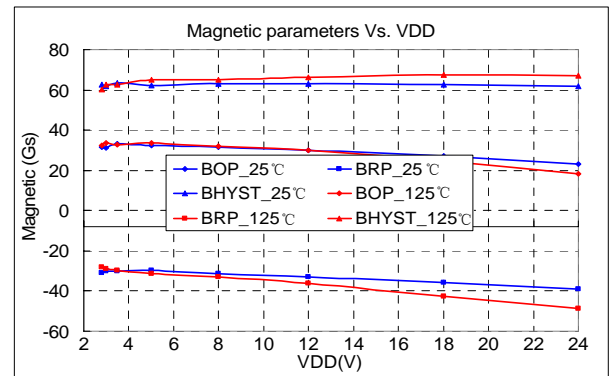

Figure 3-2. Magnetic parameters Vs. VDD

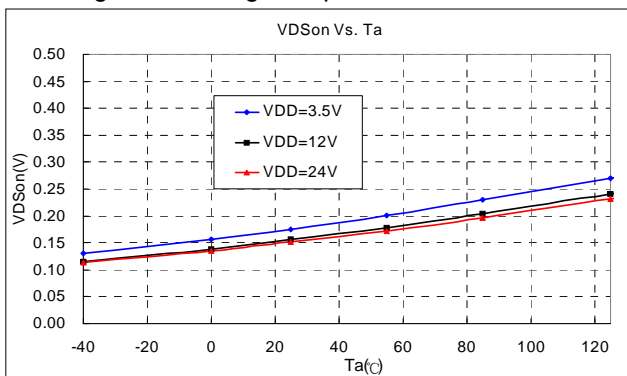

Figure 3-3. VDSon Vs. Ta

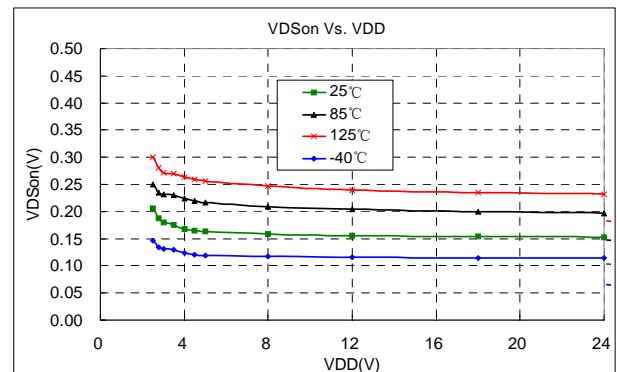

Figure 3-4. VDSon Vs. VDD

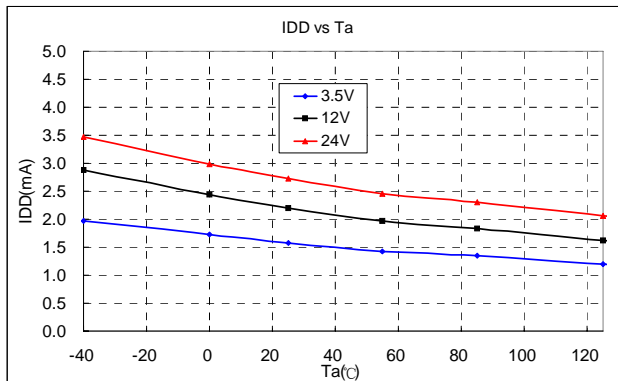

Figure 3-5. IDD Vs. Ta

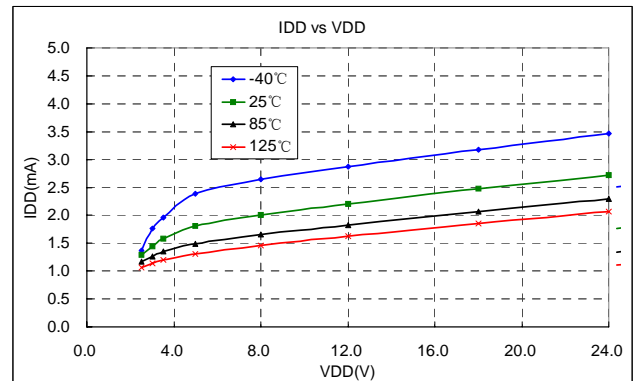

Figure 3-6. IDD Vs. VDD

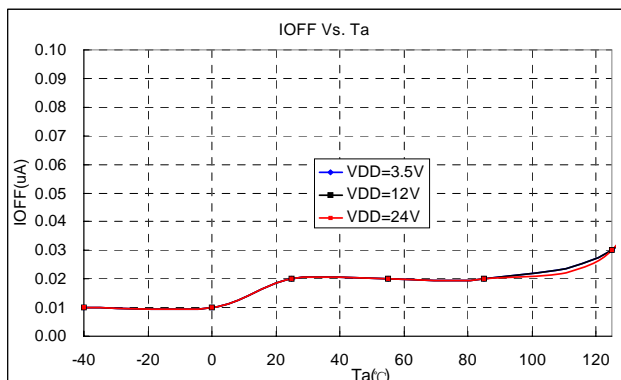

Figure 3-7. IOFF Vs. Ta

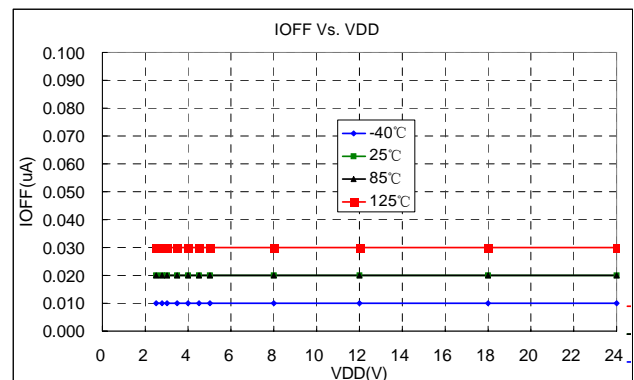
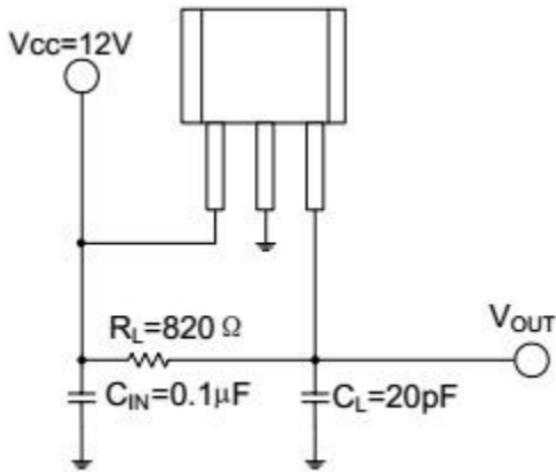

Figure 3-8. IOFF Vs. VDD

◆ Typical Application Circuit



Note: C_{IN} is used to stabilize external power supply. R_L is the pull-up resistance necessary for open collector output, with a value range of $820\Omega \sim 100K\Omega$, depending on the current capacity required by the back-end input; C_L is used to filter out the output noise. This capacitor will affect the rise time of the waveform

◆ Marking Information

(1) SIP-3L(TO-92S)

(Top View)

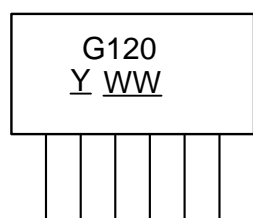

Y : Year : "1" = 2011

WW : Nth Week 01~52

(2) SOT-23-3L/SOT23

(Top View)

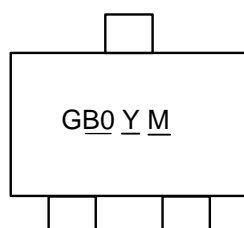

GB0: Part No. GH1120

Y : Year 0~9

M : Month A~L

◆ **Package Information** (unit: mm)

(1) UA: SIP-3L(TO-92S) for Bulk only

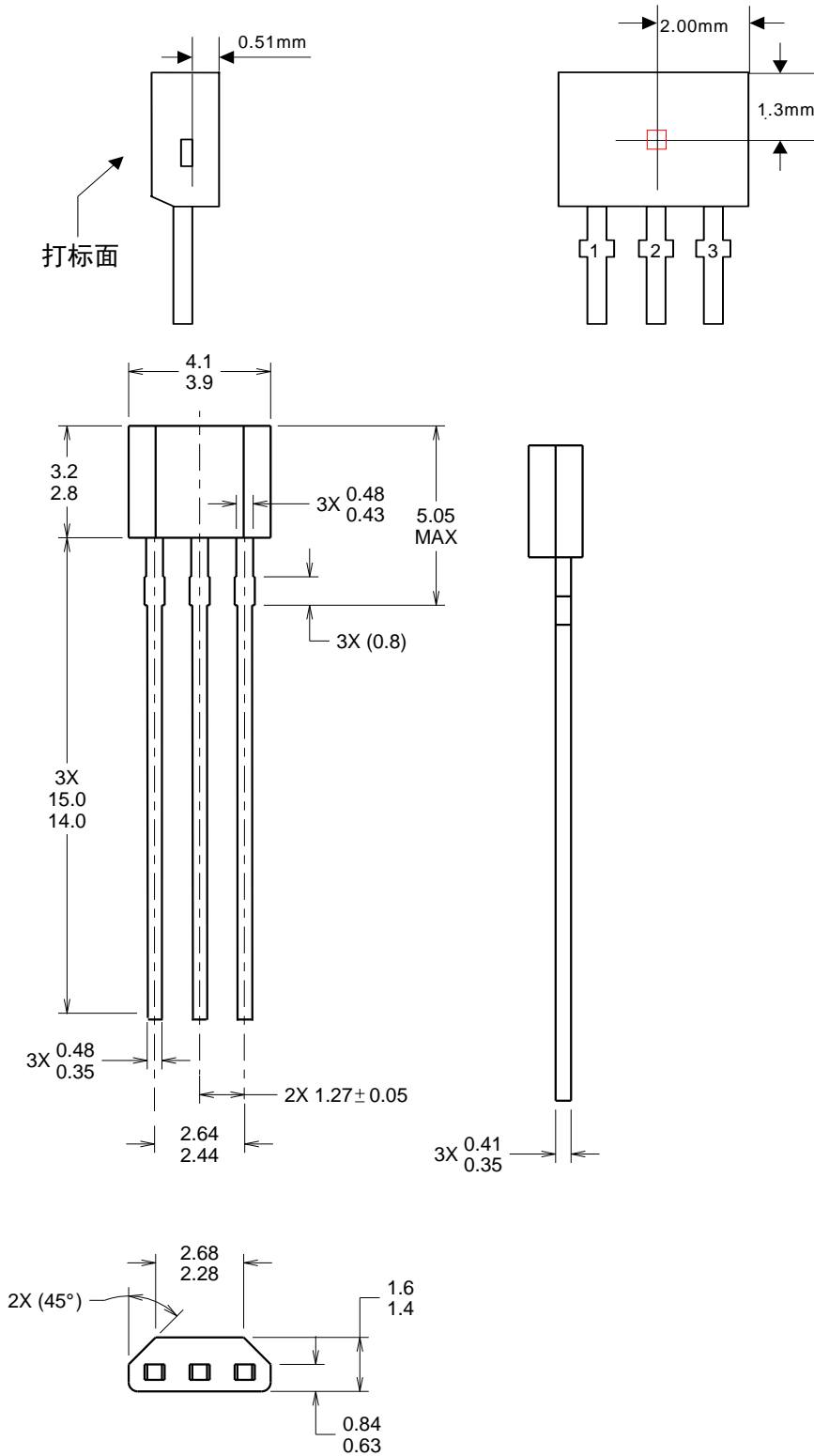

(2) SW: SOT-23-3L

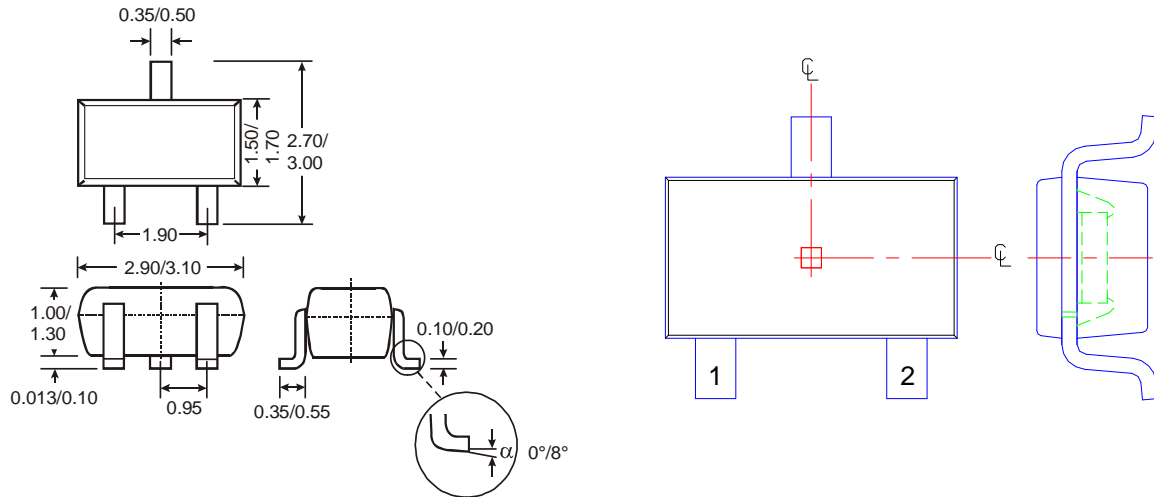

(3) SE: SOT23

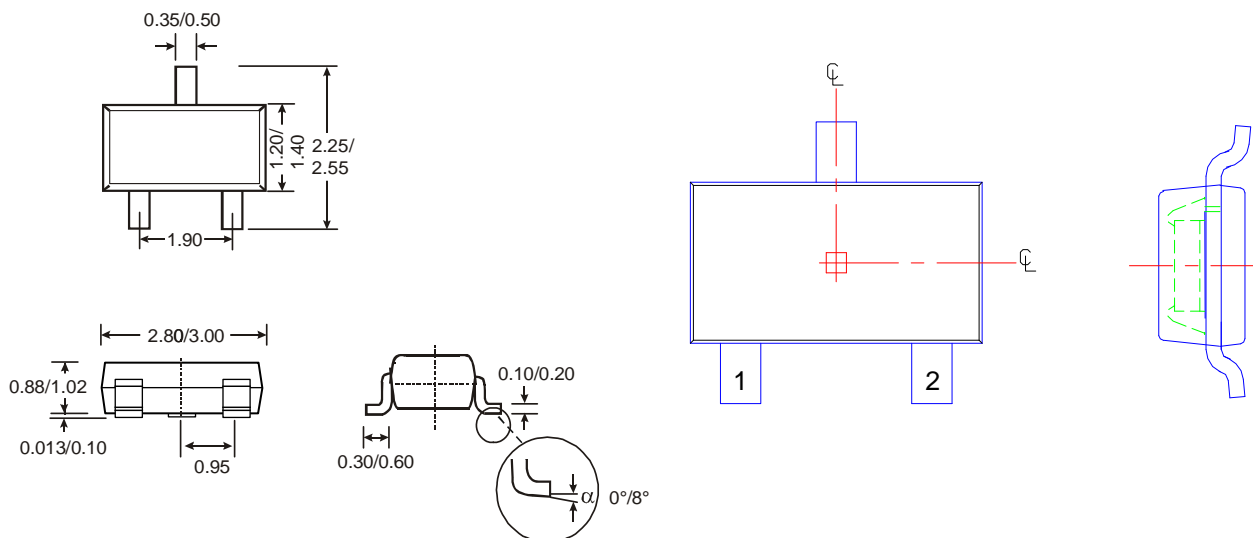

Looking for pricing, stock, or lifecycle information?

Click below to explore more details on WIN SOURCE:

- ⊖ [View GH1120KSE on WIN SOURCE](#)
- ⊖ [GoChip Information](#)

Optimize Your Supply Chain with WIN SOURCE Solutions

- ✓ Global Sourcing Solution
- ✓ Obsolete Management
- ✓ Cost Control Management
- ✓ Shortage Management
- ✓ Alternative Solution
- ✓ Excess Inventory Management