

## ◆ General Description

The GH1187 is an integrated Hall Effect latched sensor designed for electronic commutation of brush-less DC motor applications. The device includes an on-chip Hall voltage generator for magnetic sensing, a comparator that amplifies the Hall voltage, and a Schmitt to provide switching hysteresis for noise rejection, and open-collector output. An internal bandgap regulator is used to provide temperature compensated supply voltage for internal circuits and allows a wide operating supply range.

In the absence of a magnetic field, the output pin is "OFF" (High). A north pole of sufficient strength will turn the output "ON" (Low). While the magnetic flux density (B) is larger than threshold  $B_{op}$ , the output pin is "ON". If B removed toward  $B_{rp}$ , the output pin is latched "ON" state prior to  $B < B_{rp}$ . When  $B < B_{rp}$ , the output pin goes into "OFF" state.

## ◆ Typical Application

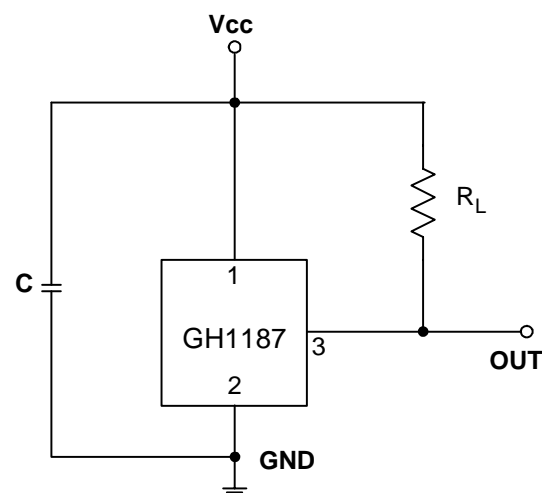
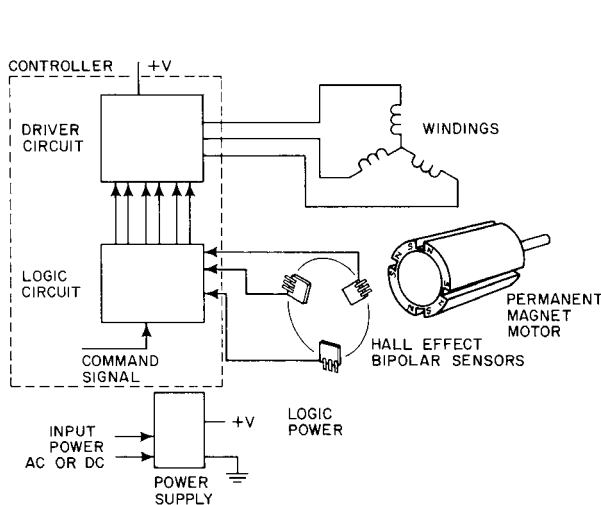

Fig.1 Typical Application of GH1187 in Brush-less DC Motor

## ◆ Features

- Bipolar Hall Effect Latch Sensor
- Wide operating voltage range: 3.8V~30V
- Open Collector Pre-Driver
- Maximum output sink current: 50mA
- Chip Power Reverse-Connection Protection
- Operating Temperature:  $-40^{\circ}\text{C}\sim+150^{\circ}\text{C}$
- Package: SIP3L (TO-92S)

## ◆ Applications

- Rotor Position Sensing
- Current Switch
- Encoder
- RPM Detection
- Brush-less DC Motor
- Brush-less DC Fan
- Revolution counting
- Speed measurement

◆ **Absolute Maximum Rating** (Note 1)

SYMBOL	PARAMETER	RATING
VCC	Supply Voltage	-30V to +30VDC
Vout (off)	Voltage externally applied to output	+40VDC max, OFF condition only -0.5 V min., OFF or ON condition
Io (sink)	Output "ON" Current	50 mA
PD	Power Dissipation	450 mW
Top	Operation Temperature Range	-40 to +150 °C
Tst	Storage Temperature Range	-65 to +160 °C
B	Magnetic Flux	No limit.

**Note 1:** Absolute Maximum Ratings are those values beyond which the life of a device may be impaired.

◆ **Pin Description**

PIN #	NAME	P/I/O	FUNCTION DESCRIPTION
1	VCC	P	Input Power Supply
2	GND	P	Ground
3	OUT	O	Output Stage of Open Collector

◆ **Pin Configuration**

SIP-3L(TO-92S)

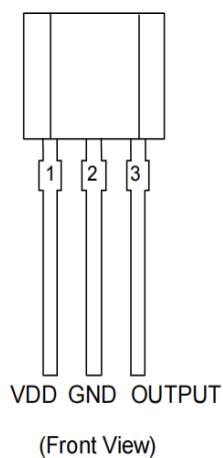

SOT23

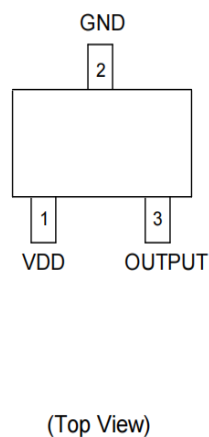

◆ Functional Block Diagram

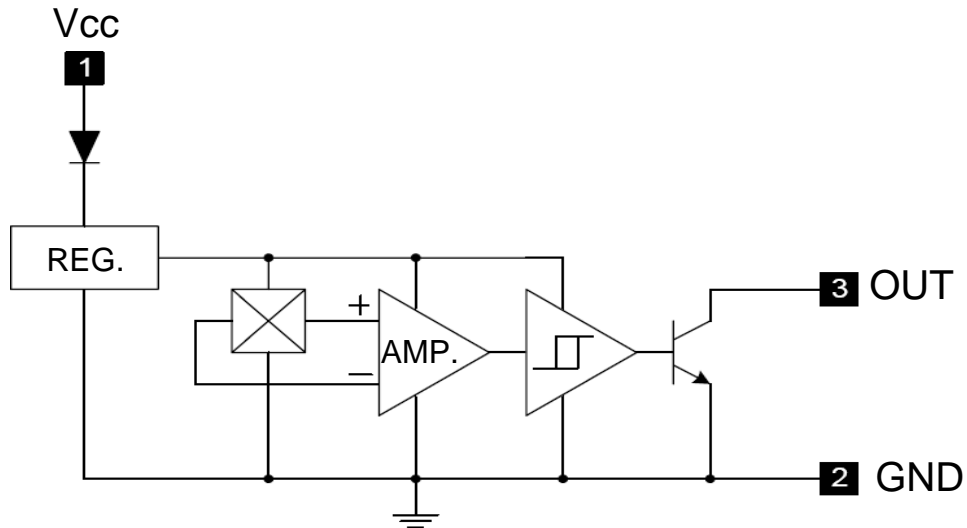

Figure 2. Function Block Diagram of GH1187

◆ Electrical Characteristics (TA = 25°C)

SYMBOL	PARAMETER	CONDITIONS	MIN.	TYP.	MAX.	UNIT
Vcc	Supply Voltage	Operating	3.8		30	V
VO(SAT)	Output Saturation Voltage	Vcc = 12V, OUT "ON", Io = 25mA	100		250	mV
		Vcc = 12V, OUT "ON", Io = 50mA	250		600	mV
Icc	Supply Current	Vcc = 3.8V~30V, OUT "OFF"		3.2	7.5	mA
I <sub>LE</sub>	Output Leakage Current (Leakage into sensor output)	Released			10	μA
Tr	Output Switching Time	Rise Time		0.2		μS
Tf		Fall Time		0.5		μS

◆ Test Circuit

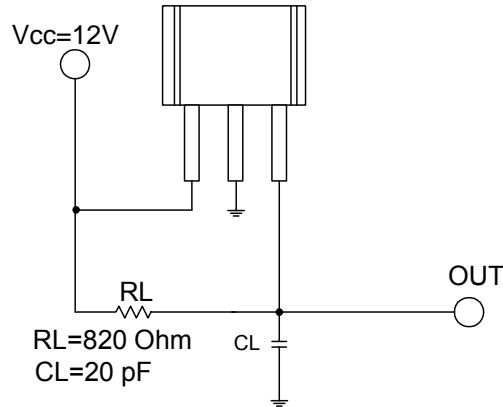
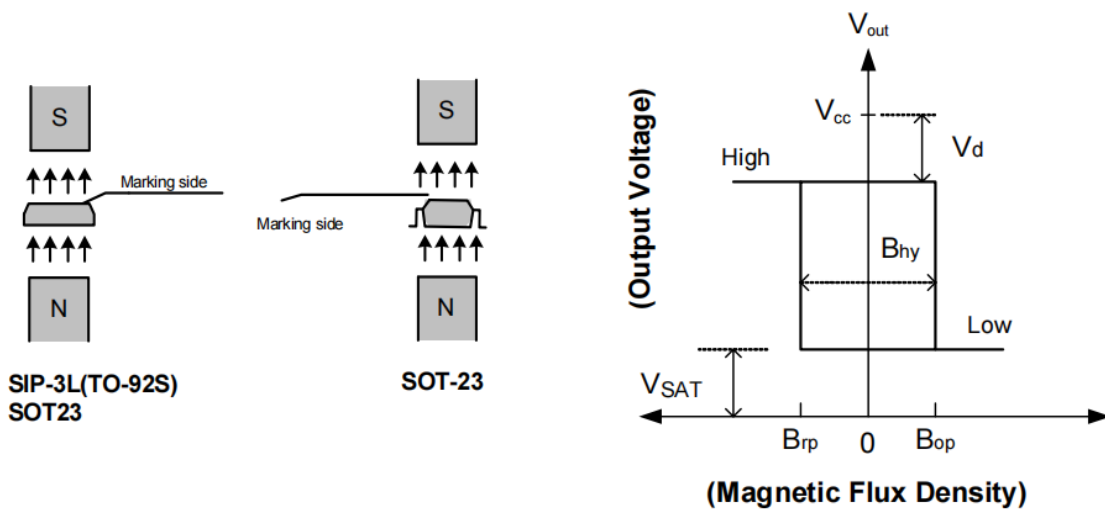

Fig 3. Test Circuit

◆ Magnetic Characteristics (TA = 25°C, Vcc = 12V)

SYMBOL	PARAMETER	MIN.	TYP.	MAX.	UNIT
Bop	Operation Point	25	100	-	Gauss
Brp	Release Point	-	-100	-25	Gauss
Bhy	Hysteresis		200		Gauss

◆ Operating Characteristics



◆ Marking Information

SIP-3L

( Top View )

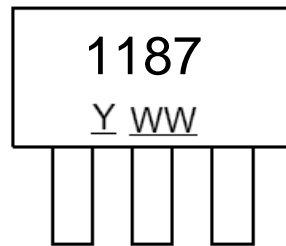

Y : Year : "8" = 2008

WW : Nth Week 01~52

◆ Package Information (unit: mm)

Package Type: SIP-3L for Bulk pack

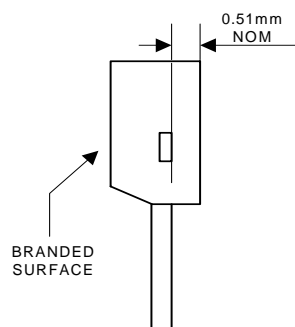

Active Area Depth

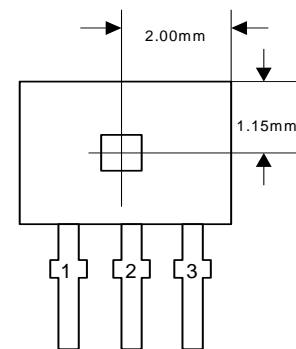

Sensor Location

Package Dimension

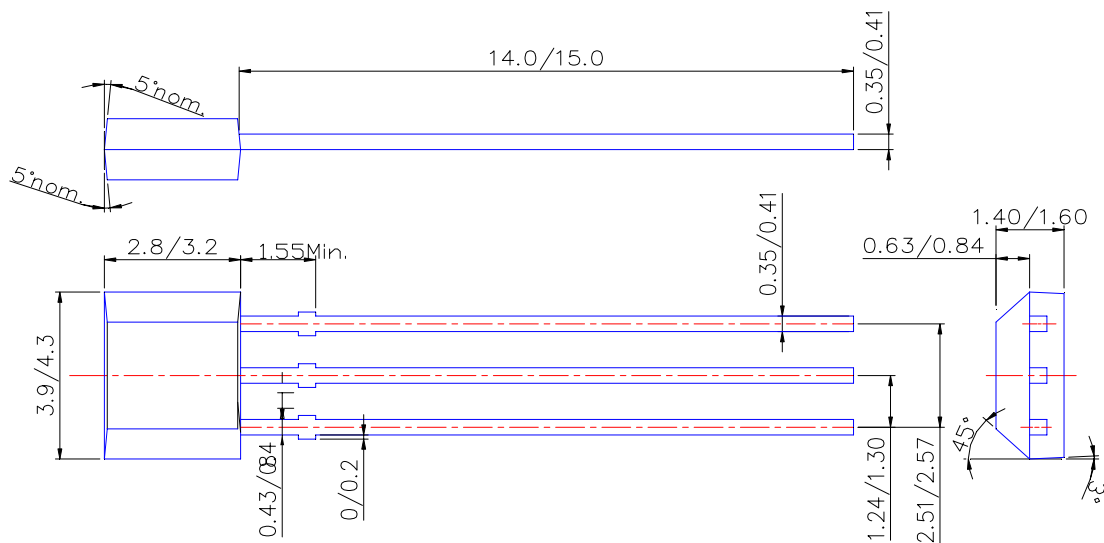

(2) SW: SOT-23-3L

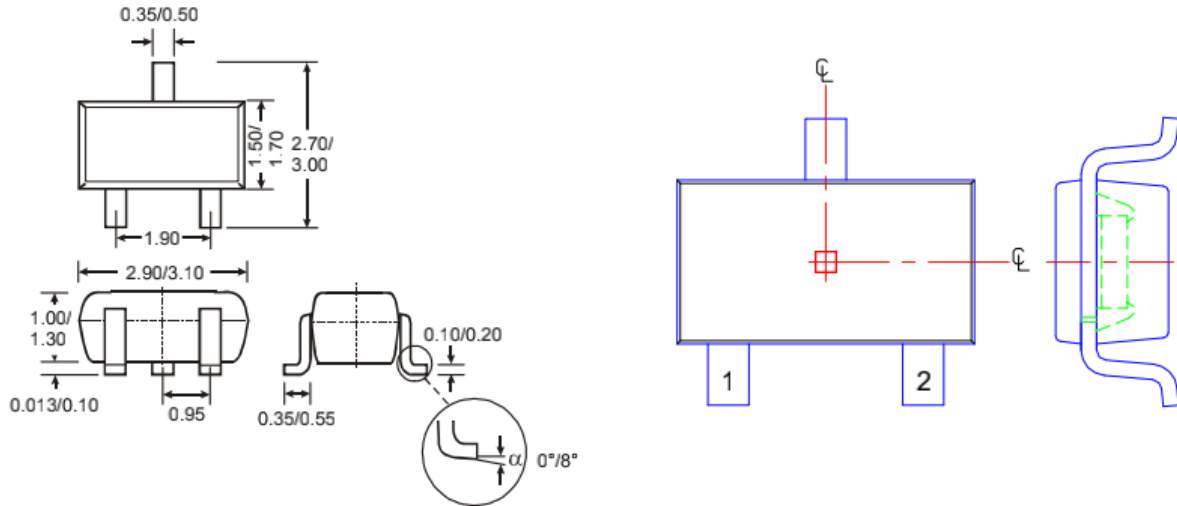

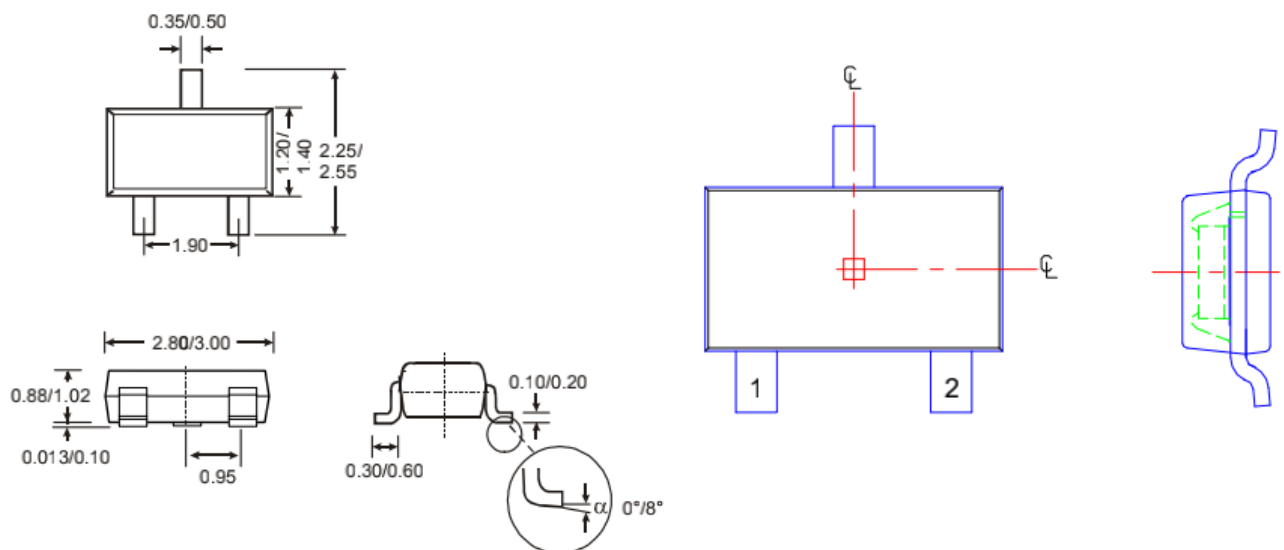

(3) SE: SOT23



## Looking for pricing, stock, or lifecycle information?

Click below to explore more details on WIN SOURCE:

-  [View GH1187 on WIN SOURCE](#)
-  [GoChip Information](#)

## Optimize Your Supply Chain with WIN SOURCE Solutions

-  Global Sourcing Solution
-  Obsolete Management
-  Cost Control Management
-  Shortage Management
-  Alternative Solution
-  Excess Inventory Management