

## ◆ General Description

The GH177 is an integrated Hall Effect latch sensor designed for electronic commutation of brush-less DC motor applications. The device includes an on-chip Hall voltage generator for magnetic sensing, a comparator that amplifies the Hall voltage, and a Schmitt to provide switching hysteresis for noise rejection, and open-collector output. An internal bandgap regulator is used to provide temperature compensated supply voltage for internal circuits and allows a wide operating supply range.

A north pole of sufficient strength will turn the output "ON" (Low). While the magnetic flux density (B) is larger than threshold  $B_{op}$ , the output pin is "ON". If B removed toward  $B_{rp}$ , the output pin is latched "ON" state prior to  $B < B_{rp}$ . When  $B < B_{rp}$ , the output pin goes into "OFF" state.

The GH177 is available in SIP-3L(TO-92S) package.

## ◆ Features

- Bipolar Hall Effect Latch Sensor
- Wide operating voltage range: 3.5V~24V
- Open Collector Pre-Driver
- Maximum output sink current: 40mA
- Chip Power Reverse-Connection Protection
- Operating Temperature: -40°C ~+125 °C
- Package: SIP3L (TO-92S)

## ◆ Applications

- Rotor Position Sensing
- Current Switch
- Encoder
- RPM Detection
- Brush-less DC Motor
- Brush-less DC Fan
- Revolution counting
- Speed measurement

## ◆ Typical Applications

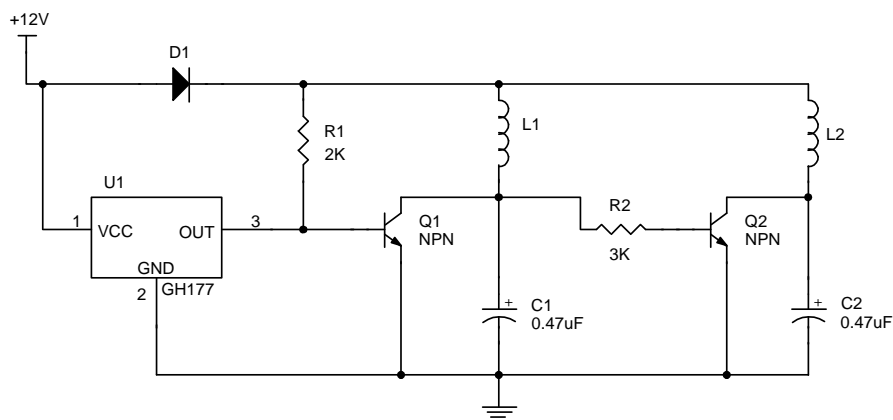

Figure 1. Typical Application of GH177 in Brush-less DC Fan.

### ◆ Pin Configuration

SIP-3L (TO-92S)

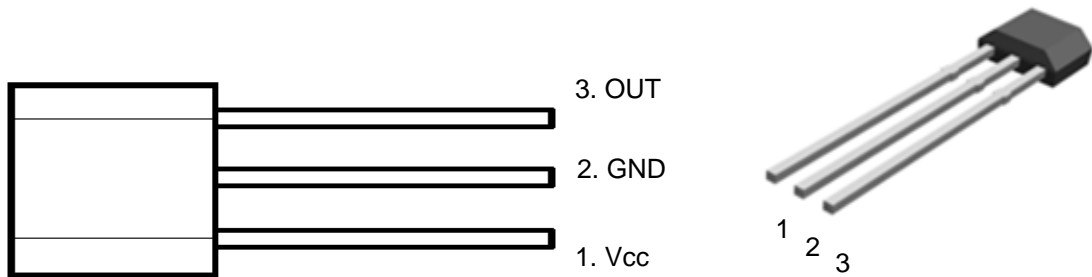

Figure 2. Pin Configuration of GH177 (Front View)

### ◆ Pin Description

PIN #	NAME	P/I/O	FUNCTION DESCRIPTION
1	VCC	P	Input Power Supply
2	GND	P	Ground
3	OUT	O	Output Stage of Open Collector

### ◆ Functional Block Diagram

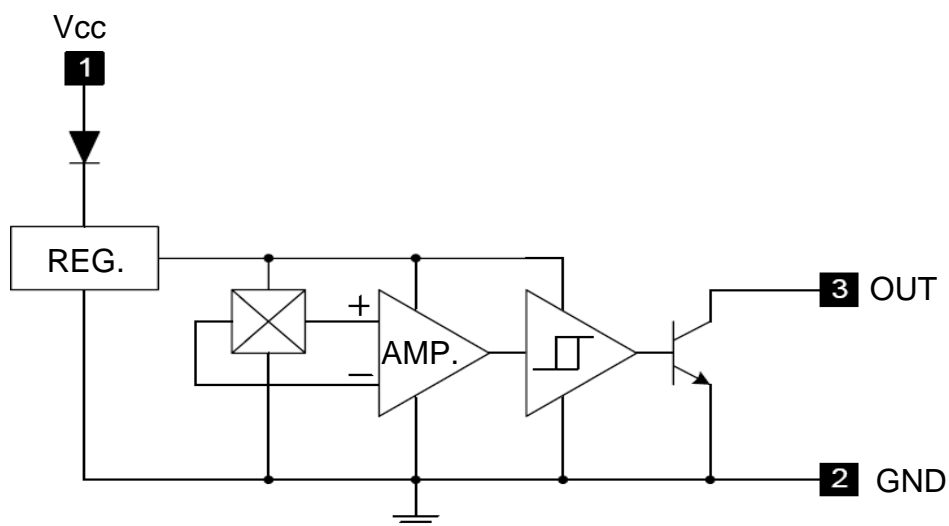

Figure 3. Function Block Diagram of GH177

◆ **Absolute Maximum Ratings (Note 1)**

( $T_A=25^{\circ}\text{C}$ )

SYMBOL	PARAMETER	RATING
VCC	Supply Voltage	-20V to +28VDC
Vout (off)	Voltage externally applied to output	+40VDC max, OFF condition only -0.5 V min., OFF or ON condition
Io (sink)	Output "ON" Current	40 mA
PD	Power Dissipation	450 mW
Top	Operation Temperature Range	-40 to +125 °C
Tst	Storage Temperature Range	-65 to +150 °C
B	Magnetic Flux	No limit.

**Note 1:** Absolute Maximum Ratings are those values beyond which the life of a device may be impaired.

◆ **Electrical Characteristics ( $T_A=25^{\circ}\text{C}$ )**

SYMBOL	PARAMETER	CONDITIONS	MIN.	TYP.	MAX.	UNIT
Vcc	Supply Voltage	Operating	3.5		24	V
V <sub>O(SAT)</sub>	Output Saturation Voltage	Vcc = 14V, OUT "ON", Io = 25mA	100		250	mV
		Vcc = 14V, OUT "ON", Io = 40mA	250		600	mV
Icc	Supply Current	Vcc = 3.5V~24V, OUT "OFF"		3.2	7.5	mA
I <sub>LE</sub>	Output Leakage Current (Leakage into sensor output)	Released			10	μA
Tr	Output Switching Time	Rise Time	RL=820Ω, CL=20pF	0.2		μS
Tf		Fall Time	RL=820Ω, CL=20pF	0.5		μS

◆ Test Circuit

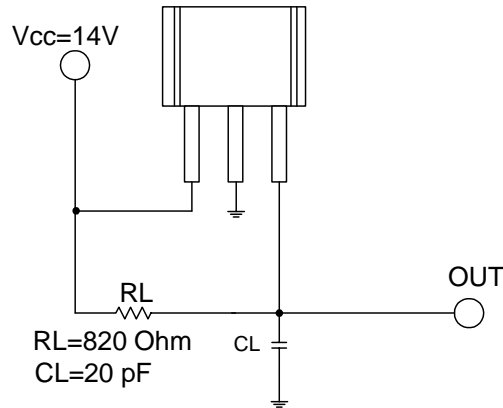

Figure 4. Test Circuit

◆ Magnetic Characteristics (TA = 25°C, Vcc = 12V)

A grade

SYMBOL	PARAMETER	MIN.	TYP.	MAX.	UNIT
Bops(south pole to brand side)	Operation Point	5		70	Gauss
Brps(south pole to brand side)	Release Point	-70		-5	Gauss
Bhy( Bopx - Brpx )	Hysteresis	-	80	-	Gauss

B grade

SYMBOL	PARAMETER	MIN	TYP.	MAX.	UNIT
Bops(south pole to brand side)	Operation Point	-	-	100	Gauss
Brps(south pole to brand side)	Release Point	-100	-	-	Gauss
Bhy( Bopx - Brpx )	Hysteresis	-	80	-	Gauss

◆ Operating Characteristics

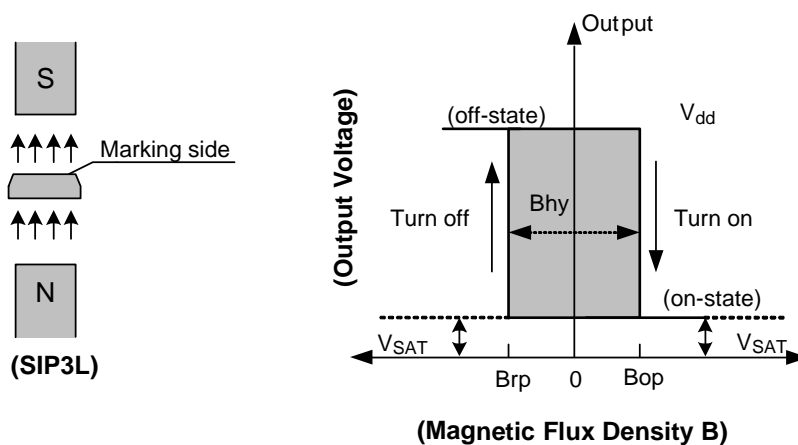
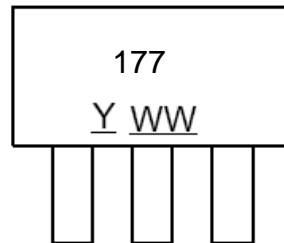

Figure 5. Operating Characteristics of GH177

◆ Marking Information

SIP-3L

( Top View )



Y : Year: "2" = 2012

WW : Nth Week 01~52

◆ Package Information (unit:mm)

Package Type: SIP-3L for Bulk pack

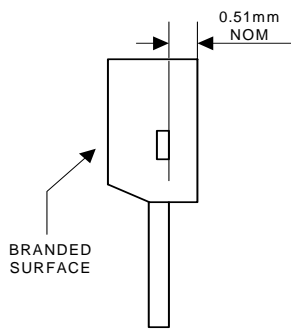

Active Area Depth

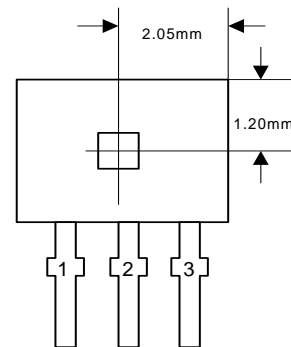

Sensor Location

Package Dimension

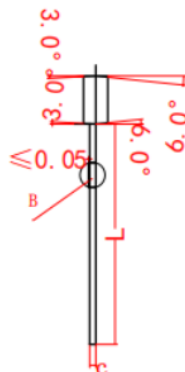
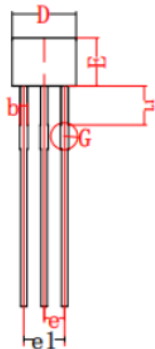
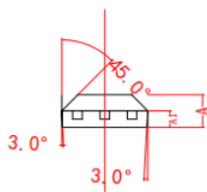

COMMON DIMENSIONS (mm)			
SYMBOL	MIN.	NOM.	MAX.
A	1.40	1.50	1.60
A1	0.70	0.77	0.85
b	0.40	0.45	0.50
c	0.36	0.38	0.40
D	3.95	4.05	4.15
e	-	1.27	-
E	2.44	2.54	2.64
L	14.0	14.5	15.0
L1	1.00	1.05	1.10

## Looking for pricing, stock, or lifecycle information?

Click below to explore more details on WIN SOURCE:

 [View GH177A on WIN SOURCE](#)

 [GoChip Information](#)

## Optimize Your Supply Chain with WIN SOURCE Solutions

-  Global Sourcing Solution
-  Obsolete Management
-  Cost Control Management
-  Shortage Management
-  Alternative Solution
-  Excess Inventory Management