

## DUAL CHANNEL DYNAMIC DIFFERENTIAL HALL SENSOR IC

### ◆ General Description

GH1820 is a differential Hall-effect sensor IC with two independent channels. Based on the working principle of the Hall effect, the strength and direction of the bias magnetic field passing through the Hall integrated circuit will change with the constant change of the position of the tooth top and tooth valley (gap) of the moving gear, so that the two different magnetic field signals sensed by the Hall sensor are converted into a differential voltage signal. After the weak voltage signal is filtered, amplified and compared adaptively, the switch unit circuit inside the trigger circuit is turned on and off, so the output end of the circuit generates a high and low level digital signal corresponding to the shape of the gear. GH1820 contains two sets of such differential Hall channels, which can output two sets of quadrature signals at the same time.

GH1820 circuit includes a voltage regulator, two sets of differential Hall sensors, temperature compensation, small signal amplifier, band-pass filter, adaptive window comparator and open-drain output stage and other unit modules. The dual-sensor differential structure design scheme minimized the impact of the performance of parameters affected by the temperature drift, manufacturing process fluctuations, and discrete bias magnetic fields.

Due to the inclusion of the internal voltage regulator unit and temperature compensation unit, GH1820 can work stably and reliably in the voltage range of 3.8~30V and the temperature range of -40~+150°C. Because of the many advantages and features of GH1820, it is especially suitable for non-zero speed gear, speed and direction detection applications.

### ◆ Features

- Operating voltage range: 3.8~30V
- Wide operating temperature range: -40~+150°C
- Maximum operating frequency: 20KHz
- Differential Hall sensor structure, high sensitivity
- Wide range of effective detection distance
- Symmetrical magnetic switch points
- Compatible output logic signal
- Resistant to physical stress and EMI electromagnetic interference
- Strong anti-shake ability, not easy to malfunction

### ◆ Applications

- Camshaft sensor
- Crankshaft sensor
- Speed and direction AC of asynchronous motor
- Tachometer and counter
- Speed and position of Sprocket
- Speed and distance of chain conveyor
- Stop motion detection

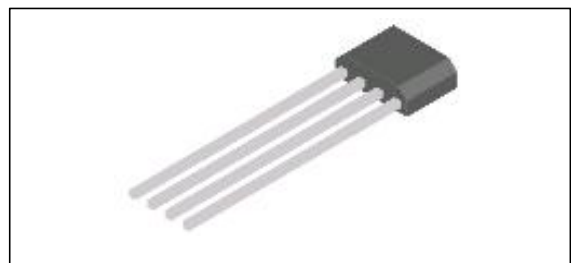

Figure 1. Package Type of GH1820

## DUAL CHANNEL DYNAMIC DIFFERENTIAL HALL SENSOR IC

### ◆ Ordering Information

Product	Package	Marking ID	Packing Type	Quantity
GH1820LUB	TO-94(SIP-4L)	GH1820	Pack	1000 pcs

### ◆ Pin Configuration

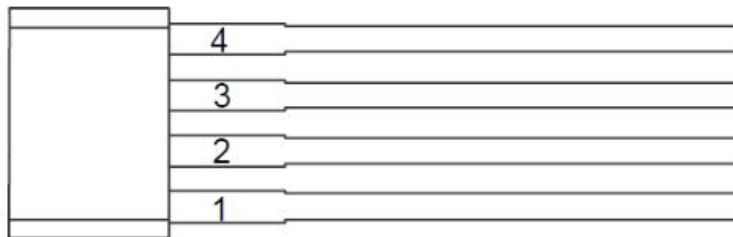

Pin	Pin Name	Function
1	VCC	Power supply
2	OUTA	Open drain output A
3	OUTB	Open drain output B
4	GND	GND

### ◆ Functional Block Diagram

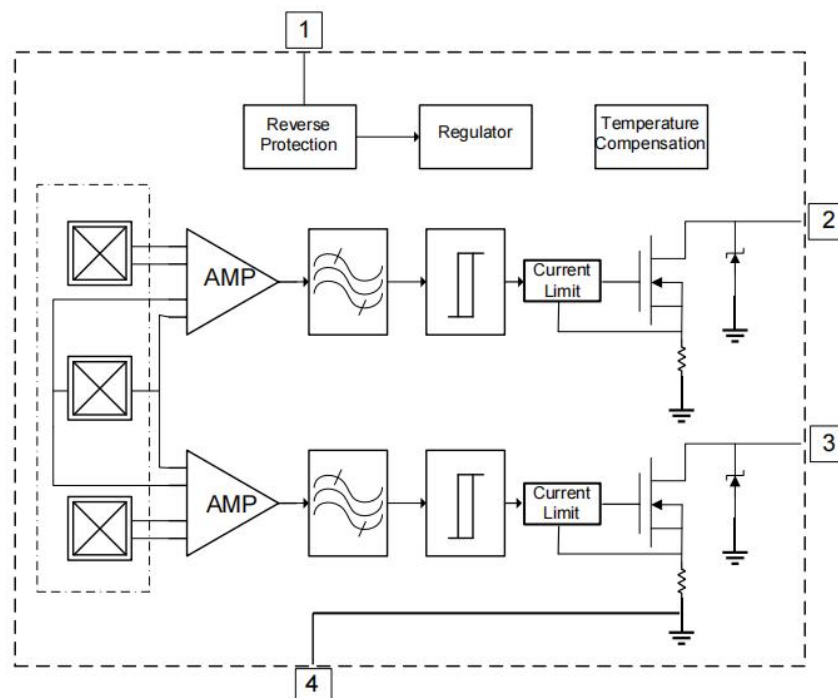

Figure 2 Block Diagram

## DUAL CHANNEL DYNAMIC DIFFERENTIAL HALL SENSOR IC

### ◆ Absolute Maximum Ratings

$T_A = 25^\circ\text{C}$  (Note 1)

Parameter	Symbol	Value	Unit
Supply voltage	$V_{CC}$	-30~30	V
Output voltage	$V_{OUT(OFF)}$	-0.7~+30, output off	V
Output low level current	$I_{OUT(SINK)}$	30	mA
Max power dissipation	$P_D$	500	mW
Operation temperature	$T_{OP}$	-40~+150	$^\circ\text{C}$
Junction temperature	$T_{J(max)}$	+165	$^\circ\text{C}$
Storage temperature	$T_{ST}$	-65~+170	$^\circ\text{C}$

### ◆ Electrical Characteristics

$V_{DD} = 12\text{V}$ ,  $T_A = 25^\circ\text{C}$ , unless otherwise specified.

Parameter	Symbol	Condition	Min	Typ	Max	Unit
Supply voltage(note2)	$V_{CC}$	正常工作时	3.8	--	30	V
Output low voltage	$V_{OUT(SAT)}$	$I_{OUT} = 20\text{mA}$ , output on	--	400	600	mV
Output leakage current	$I_{OL}$	$V_{OUT} = 12\text{V}$ , output off	--	--	45	$\mu\text{A}$
Supply current	$I_{CC}$	$V_{CC} > 4.5\text{V}$ , output off	5	7	9	mA
Output current limit	$I_{OUT(LIM)}$		--	30	--	mA
Power-On time	$t_{PO}$	$V_{CC} \geq V_{CC(MIN)}$	--	25	100	$\mu\text{s}$
Initial output state	POS	$T < t_{PO} + t_{SETR}$	--	高电平	--	--
Output rise time(note3)	$t_r$	$R_L = 1\text{k}\Omega$ , $C_{OUT} = 10\text{pF}$	--	--	200	ns
Output fall time	$t_f$	$R_L = 1\text{k}\Omega$ , $C_{OUT} = 10\text{pF}$	--	--	200	ns
Operating point	$\Delta B_{OP}$	$f_{OP} = 200\text{Hz}$ , $B = 200\text{Gs}$	-10	0	10	Gs
Release point	$\Delta B_{RP}$	$f_{OP} = 200\text{Hz}$ , $B = 200\text{Gs}$	-10	0	10	Gs
Operating frequency	$f_{CU}$	-3dB	20	--	--	KHz
Operating frequency	$f_{CL}$	-3dB	--	--	15	Hz

Note:

- 1) If any one of the maximum ratings is exceeded, the device may be damaged.
- 2) The maximum power supply voltage that can work normally must be adjusted according to the constraints of junction temperature and power consumption.
- 3) This parameter is not mainly affected by the internal circuit of GH1836, it is mainly determined by the external interface circuit.

## DUAL CHANNEL DYNAMIC DIFFERENTIAL HALL SENSOR IC

### ◆ Functional Description

Magnetic field lines will deviate from the original direction and be distorted near iron and other magnetically conductive materials, so the direction of magnetic field lines and magnetic field strength will change with the movement of the iron gear. GH1820 contains two sets of independent Hall sensor pairs. If one Hall sensor faces the tooth top of the gear and the other Hall sensor faces the tooth valley (tooth gap) of the gear, then a differential magnetic field signal is generated. As the gear changes from the top to the valley, the polarity of the differential magnetic field signal will also change at the same speed. The corresponding magnetic field change is converted into a voltage signal by the internal signal processing circuit to trigger and control the output stage circuit. Make it switch between on (output low level) and

off (output high level) state. When the differential magnetic field signal exceeds BRP, the output of GH1820 will be turned off ( $V_{out}$  is high). As the differential magnetic field signal is lower than BOP, the output of GH1820 will turn on ( $V_{out}$  is low). It should be pointed out that there is no change in the magnetic field in static state, so the output signal is uncertain.

When the chip is applied to detect a gear with magnetic cohesion, a permanent magnet is affixed on the back of the screen, which covers two sets of Hall sensing heads, and the maximum detection distance when the gear is close depends on the magnetic field strength and the parameters of the gear used.

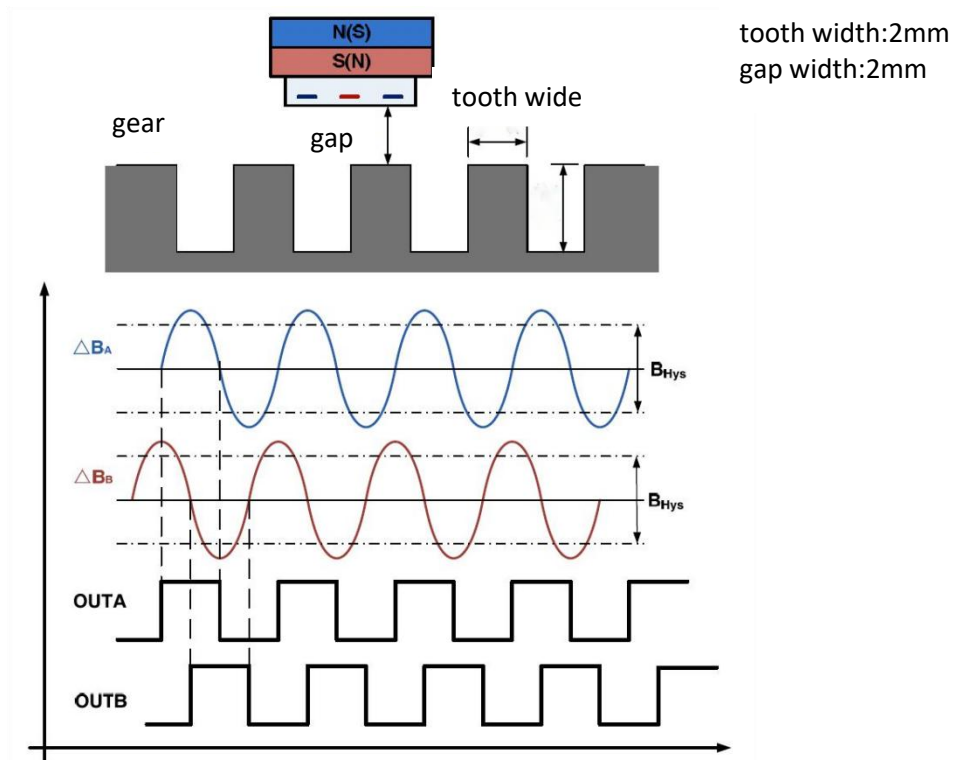

Figure 3 The basic working principle of GH1820 when used as a gear sensor

## DUAL CHANNEL DYNAMIC DIFFERENTIAL HALL SENSOR IC

### ◆ Typical Application

#### Application under stable power supply

GH1820 generally does not require additional complicated protection circuits, because the on-chip voltage regulator contained in it can withstand the changes and fluctuations of the external power supply within 3.8~30V. However, when applied in an environment with high spurious noise, it is recommended to add a basic RC low-pass filter ( $R_{IN}$ & $C_{IN}$ ) to the power line, and as an option, you can also add an output capacitor ( $C_{OUT}$ ) to the output. As shown in Figure 4 (A). Since GH1820 uses an open-drain output stage structure, the pull-up resistor  $R_L$  at the output is essential.

#### Application under unstable power supply

When used in complex and harsh environments such as automobiles, the power supply of the GH1820 sensor comes from an unstable power supply such as a battery. Generally, sufficient protection is required to make the sensor withstand the transient changes and interference from the positive and negative poles of the power supply. The specifications of this voltage transient and

interference will be different between different automobile manufacturers, so the corresponding protection circuit should be optimized for each specific application. Figure 4(B) is a simple protection circuit using discrete components. The RC low-pass filter ( $R_{IN}$ & $C_{IN}$ ) on the power line is used to filter out EMI/RFI interference, and the Zener diode ( $D_z$ ) is used to over-voltage protection; for voltage protection below 30V, the internal circuit of GH1820 can be adequately guaranteed. The series resistance ( $R_{IN}$ ) provides the current limit and forms a low-frequency noise filter together with the capacitor ( $C_{IN}$ ). The size of the Zener diode and the current-limiting resistor should consider the power consumption requirements. The series diode ( $D_s$ ) is used as a connection protection to avoid the impact of the reverse transient voltage on the external Zener diode and the internal circuit of the GH1820, so the series diode must have a sufficiently large reverse breakdown voltage.

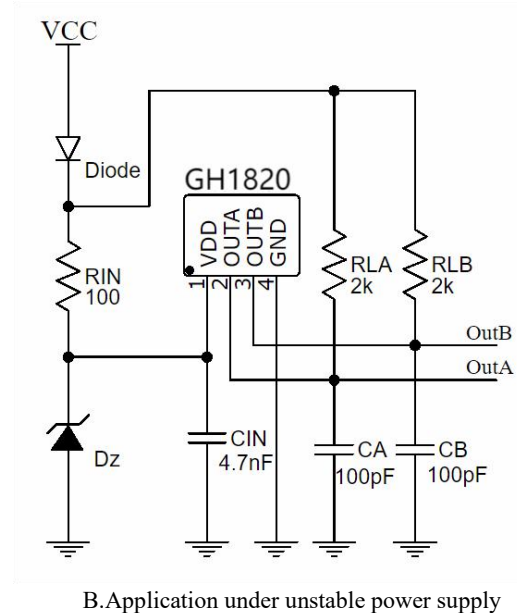
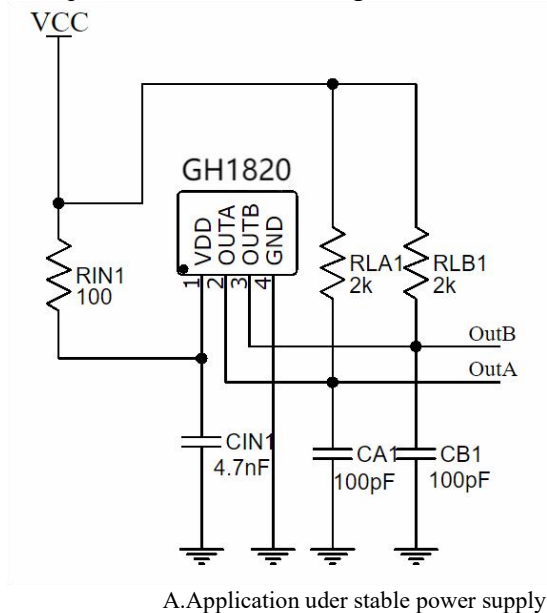

- $R_{LA}, R_{LB}=2K\Omega$
- $R_{IN}=100\Omega, R_{IN}$  is optional, not necessary
- $C_{IN}=4.7nF, C_{IN}$  is optional, not necessary
- $C_A, C_B=100pF, C_A \& C_B$  is optional, not necessary
- $DZ$  is a Zener diode,  $DZ > VCC$  and  $DZ < 20V, DZ$  is optional, not necessary

Figure.4 Typical application schematics of GH1820

## DUAL CHANNEL DYNAMIC DIFFERENTIAL HALL SENSOR IC

### ◆ Marking Information

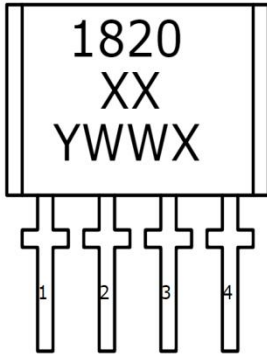

GH1820:Part Number  
XX:Version Number  
Y:Year Number  
WW:Week Number  
X:Special Mark

### ◆ Package Information

TO-94(SIP-4L) Unit:mm

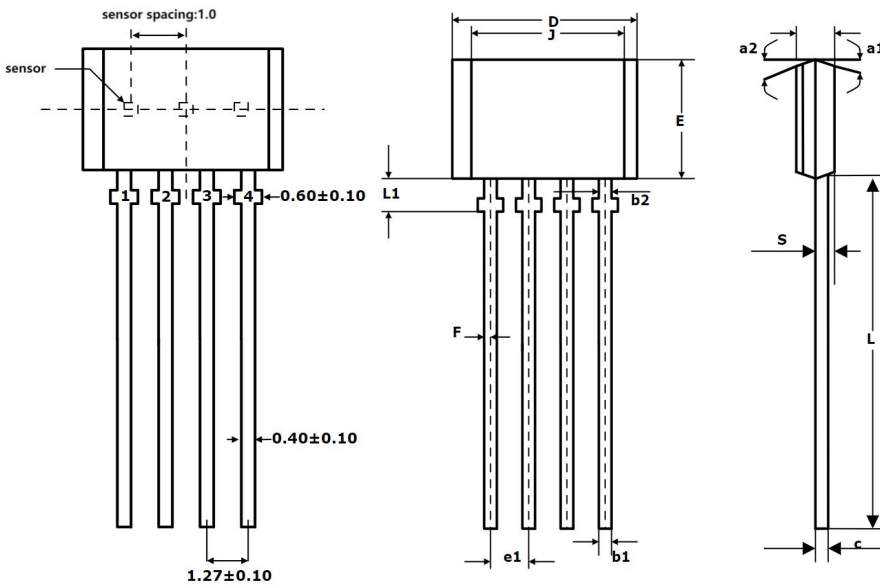



Size	MIN.	MAX.	TYP.
<b>A</b>	1.45	1.65	1.55
<b>b1</b>	0.38	0.44	0.40
<b>b2</b>	-	-	0.48
<b>c</b>	0.35	0.45	0.40
<b>D</b>	5.12	5.32	5.22
<b>e1</b>	1.24	1.30	1.27
<b>E</b>	3.55	3.75	3.65
<b>F</b>	0.00	0.20	-
<b>J</b>	4.10	4.30	4.20
<b>L</b>	14.00	14.60	14.30
<b>L1</b>	1.32	1.52	1.42
<b>S</b>	0.63	0.83	0.73
<b>a1</b>	-	5°	3°
<b>a2</b>	4°	7°	5°
<b>a3</b>	10°	12°	11°
<b>a4</b>	5°	7°	6°

Unit: mm

## Looking for pricing, stock, or lifecycle information?

Click below to explore more details on WIN SOURCE:

-  [View GH1820 on WIN SOURCE](#)
-  [GoChip Information](#)

## Optimize Your Supply Chain with WIN SOURCE Solutions

-  Global Sourcing Solution
-  Obsolete Management
-  Cost Control Management
-  Shortage Management
-  Alternative Solution
-  Excess Inventory Management