

DYNAMIC DIFFERENTIAL HALL SENSOR IC

◆ General Description

GH1922 is a high-precision differential effect sensor IC. Based on the working principle of the Hall effect, the strength and direction of the bias magnetic field passing through the Hall IC will change with the teeth of the moving gear. The positions of the top and tooth valleys (tooth gap) change continuously, so that the difference between the magnetic field signals sensed by the two differential Hall sensors is transformed into a differential voltage signal. After this weak voltage signal is filtered, amplified and adaptively compared, the switch unit circuit inside the trigger circuit is turned on and off, so the output of the circuit generates a high and low level digital signal corresponding to the shape of the gear. The GH1922 circuit contains unit modules such as voltage regulator, differential Hall sensor, temperature compensation, small signal amplifier, band-pass filter, adaptive window comparator and open-drain output stage. It uses a dual-sensor differential structure to sense the difference of the magnetic field change, instead of a single sensor to sense the absolute change of the magnetic field. This design scheme minimizes the effects of temperature drift, manufacturing process fluctuations, and dispersion of bias magnetic fields on performance. Due to the internal voltage regulator unit and temperature compensation unit,

GH1922 can work stably and reliably in the voltage range of 3.5~24V and the temperature range of -40~+150°C. Because of the many advantages and features of GH1922, it is particularly suitable for non-zero speed gear, position, time and other detection applications.

◆ Features

- Operating voltage range: 3.5~24V
- Wide operating temperature range: -40~+150°C
- Maximum operating frequency: 20KHz
- Differential Hall sensor structure, high sensitivity
- Wide range of effective detection distance
- Symmetrical magnetic switch points
- Compatible output logic signal

◆ Applications

- Camshaft sensor
- Crankshaft sensor
- Speed and position detection
- Tachometer and counter
- Sprocket speed
- Speed and distance of chain conveyor
- Stop motion detection

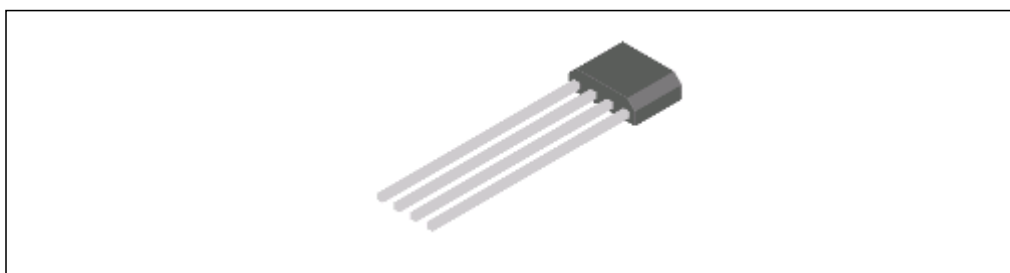

Figure 1. Package Type of GH1922

DYNAMIC DIFFERENTIAL HALL SENSOR IC

◆ Ordering Information

Product	Package	Marking ID	Packing Type	Quantity
GH1922LUB	TO-94(SIP-4L)	GH1922	Pack	1000 pcs

◆ Pin Configuration

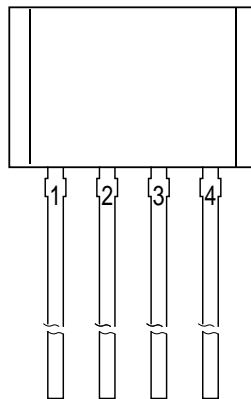

Pin Number	Pin Name	Function
1	VCC	Power supply
2	OUT	Open drain output
3	GND	GND
4	TEST	Test pin (can be suspended or grounded in actual application)

DYNAMIC DIFFERENTIAL HALL SENSOR IC

◆ Functional Block Diagram

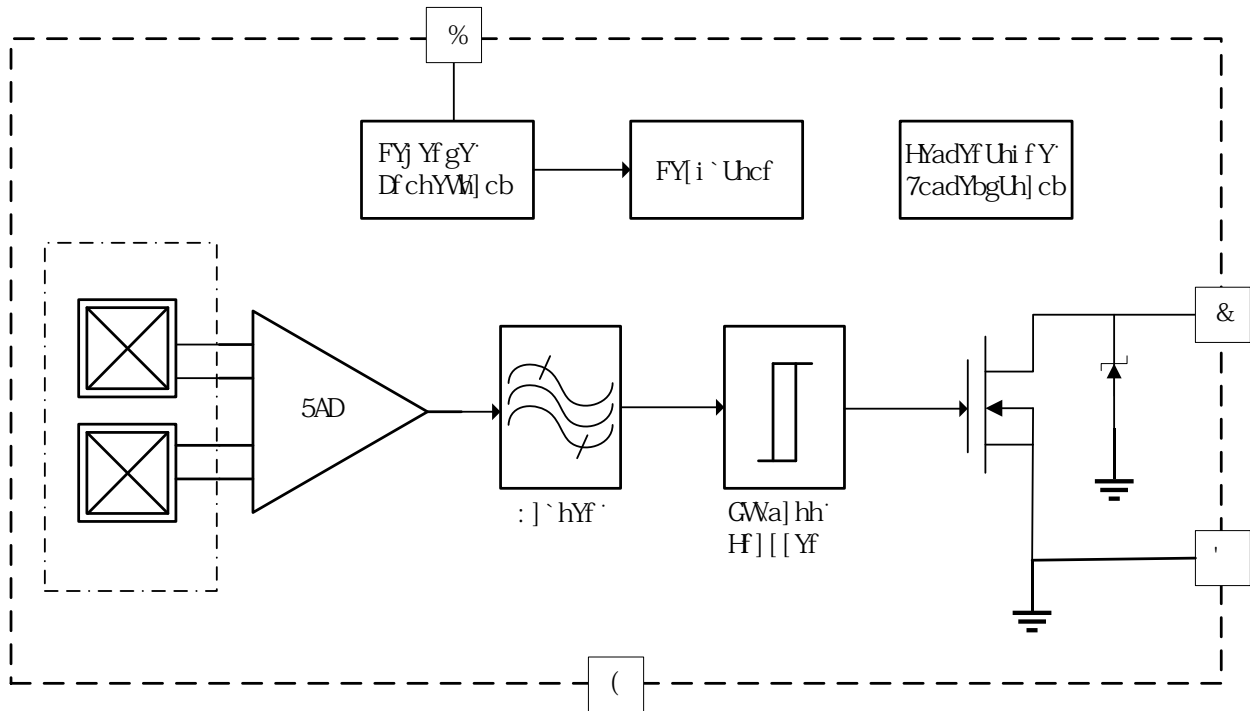

Fig.2 Block Diagram

DYNAMIC DIFFERENTIAL HALL SENSOR IC

◆ Absolute Maximum Ratings

$T_A = 25^\circ\text{C}$ (Note 1)

Parameter	Symbol	Min	Max	Unit	Condition
Supply voltage	V_{CC}	- 27	27	V	
Output voltages	$V_{OUT(OFF)}$	- 0.7	24	V	output off
Output low level current	$I_{OUT(SINK)}$		30	mA	
Max power dissipation	P_D		500	mW	
Operation temperature	T_{OP}	- 40	150	$^\circ\text{C}$	
Junction temperature	T_J	- 40	165	$^\circ\text{C}$	
Storage temperature	T_{STG}	- 65	170	$^\circ\text{C}$	

◆ Electrical Characteristics

$V_{CC} = 12\text{V}$, $T_A = 25^\circ\text{C}$, unless otherwise specified.

Parameter	Symbol	Condition	Min	Typ	Max	Unit
Supply voltage (2)	V_{CC}		12	12	12	V
Output low voltage	V_{OL}	$I_{OL} = 10\text{mA}$	0.1	0.1	0.1	V
Output leakage current	I_{OL}	$V_{OL} = 0.1\text{V}$	- 1	- 1	1	mA
Supply current	I_{CC}	$V_{CC} = 12\text{V}$	10	10	10	mA
Output current limit	I_{OL}		- 10	- 10	- 10	mA
Power-On time	t_{PU}	$V_{CC} = 12\text{V}$	10	10	10	ms
Set up time	t_{SU}	$V_{CC} = 12\text{V}$	10	10	10	ms
Initial output state	Output	$V_{CC} = 12\text{V}$	High	High	--	--
Output rise time (3)	t_r	$R_L = 1\text{k}\Omega$, $C_{OUT} = 10\text{pF}$	--	--	200	ns
Output fall time	t_f	$R_L = 1\text{k}\Omega$, $C_{OUT} = 10\text{pF}$, $I_{SINK} = 20\text{mA}$	--	--	200	ns
Operating frequency	f_{CU}	-3dB	20	--	--	kHz
Operating frequency	f_{CL}	-3dB	--	--	15	Hz
Operating point	B_{OP}	$F_{OP} = 200\text{Hz}$, $\Delta B = 200\text{Gs}$	-11	0	11	Gs
Release point	B_{RP}	$F_{OP} = 200\text{Hz}$, $\Delta B = 200\text{Gs}$	-11	0	11	Gs
Magnetic field strength	B		50	--	1250	Gs

Note:

- 1) If any one of the maximum ratings is exceeded, the device may be damaged.
- 2) The maximum power supply voltage that can work normally must be adjusted according to the constraints of junction temperature and power consumption.
- 3) This parameter is not mainly affected by the internal circuit of GH1922, it is mainly determined by the external interface circuit.

DYNAMIC DIFFERENTIAL HALL SENSOR IC

◆ Functional Description

Magnetic field lines will deviate from the original direction and be distorted near iron and other magnetically conductive materials, so the direction of magnetic field lines and magnetic field strength will change with the movement of the iron gear. GH1922 contains a set of independent Hall sensor pairs. If one Hall sensor faces the tooth top of the gear and the other Hall sensor faces the tooth valley (tooth gap) of the gear, then a differential magnetic field signal is generated. As the gear changes from the top to the valley, the polarity of the differential magnetic field signal will also change at the same speed.

The corresponding magnetic field change is converted into a voltage signal by the internal signal processing circuit to trigger and control the output stage circuit. Make it switch between on (output low level) and off (output high level) state. When the differential magnetic field signal exceeds BRP, the output of GH1922 will be turned off (VOUT is high). As the differential magnetic field signal is lower than BOP, the output of GH1922 will turn on (VOUT is low). It should be pointed out that there is no change in the magnetic field in static state, so the output signal is uncertain.

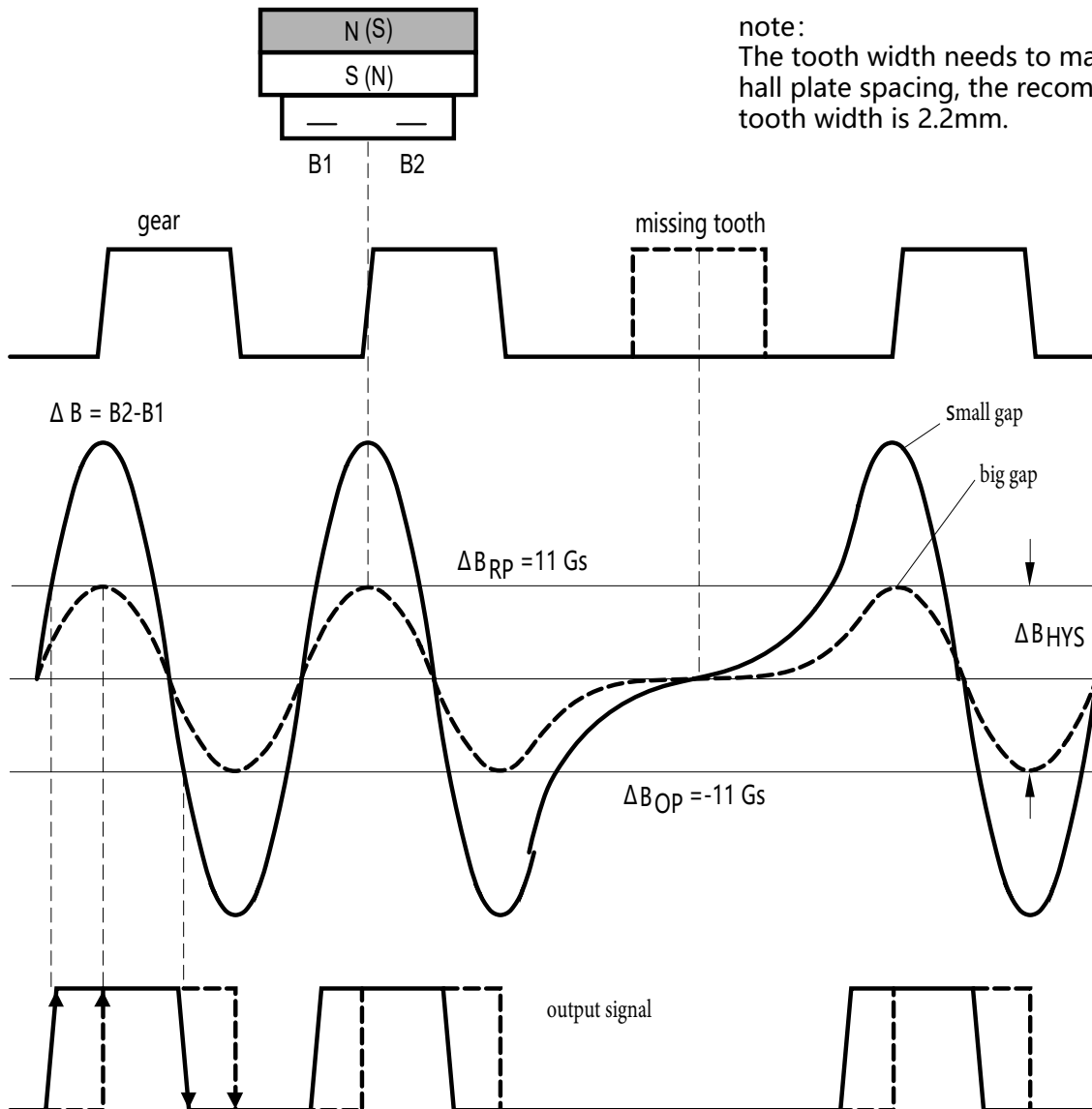

Fig.3 The basic working principle of GH1922 when used as a gear sensor

DYNAMIC DIFFERENTIAL HALL SENSOR IC

◆ Typical Application

Application under stable power supply

GH1922 generally does not require additional complicated protection circuits, because the on-chip voltage regulator contained in it can withstand the changes and fluctuations of the external power supply within 3.5~24V. However, when applied in an environment with high spurious noise, it is recommended to add a basic RC low-pass filter (RIN&CIN) to the power line, and as an option, you can also add an output capacitor (COUT) to the output. As shown in Figure 4 (A). Since GH1922 uses an open-drain output stage structure, the pull-up resistor RL at the output is essential.

Application under unstable power supply

When used in complex and harsh environments such as automobiles, the power supply of the GH1922 sensor comes from an unstable power supply such as a battery. Generally, sufficient protection is required to make the sensor withstand the transient changes and interference

from the positive and negative poles of the power supply. The specifications of this voltage transient and interference will be different between different automobile manufacturers, so the corresponding protection circuit should be optimized for each specific application. Figure 4(B) is a simple protection circuit using discrete components. The RC low-pass filter (RIN&CIN) on the power line is used to filter out EMI/RFI interference, and the Zener diode (Dz) is used to over-voltage protection; for voltage protection below 24V, the internal circuit of GH1922 can be adequately guaranteed. The series resistance (RIN) provides the current limit and forms a low-frequency noise filter together with the capacitor (CIN). The size of the Zener diode and the current-limiting resistor should consider the power consumption requirements. The series diode (DS) is used as a connection protection to avoid the impact of the reverse transient voltage on the external Zener diode and the internal circuit of the GH1922, so the series diode must have a sufficiently large reverse breakdown voltage.

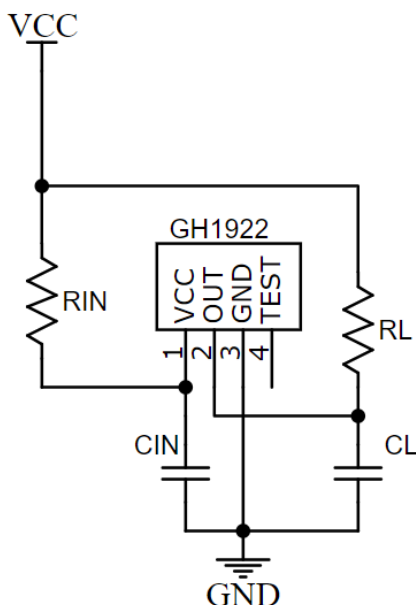

A. Application under stable power supply

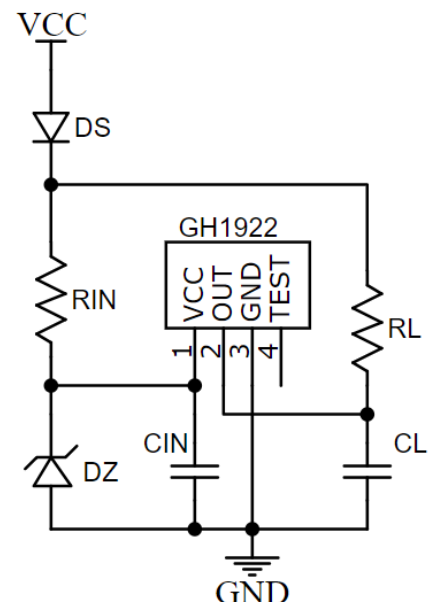

B. Application under unstable power supply

RL=2kΩ, RIN=100Ω, RIN is optional, not necessary
 CIN=4.7nF, CL= 100pF, CIN & CL is optional, not necessary
 DZ is a Zener diode, DZ >VCC and DZ <20V, DZ is an option
 the TEST pin can be left floating or grounded if it is not necessary

Fig.4 Typical application schematics of GH1922

DYNAMIC DIFFERENTIAL HALL SENSOR IC

◆ Marking Information

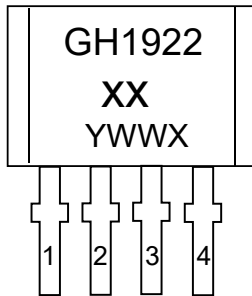

GH1922 : Part Number.

Y : Year Number., 0~9. e.g. 8 = 2018

WW: Week Number, 01~52

X: Special Mark

◆ Package Information

TO-94/SIP-4L Unit:mm

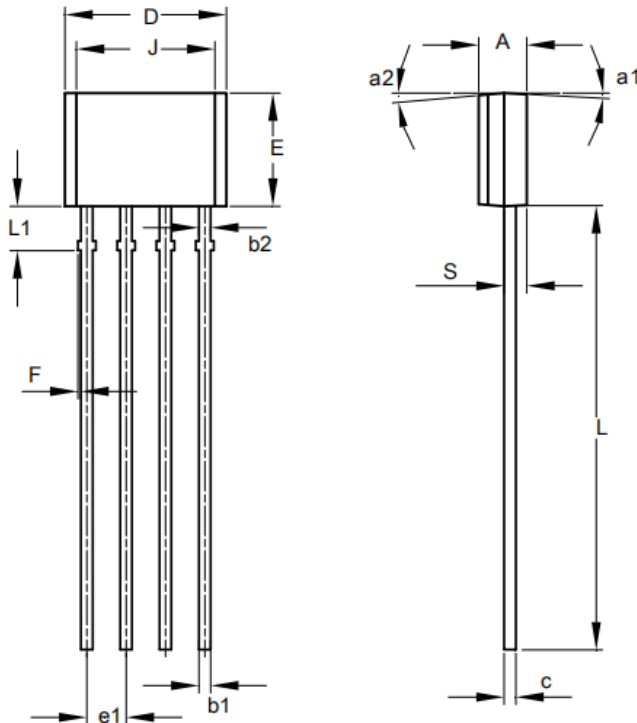

Size	MIN.	MAX.	TYP.
A	1.45	1.65	1.55
b1	0.38	0.44	0.40
b2	-	-	0.48
c	0.35	0.45	0.40
D	5.12	5.32	5.22
e1	1.24	1.30	1.27
E	3.55	3.75	3.65
F	0.00	0.20	-
J	4.10	4.30	4.20
L	14.00	14.60	14.30
L1	1.32	1.52	1.42
S	0.63	0.83	0.73
a1	-	5°	3°
a2	4°	7°	5°
a3	10°	12°	11°
a4	5°	7°	6°

Unit: mm



Looking for pricing, stock, or lifecycle information?

Click below to explore more details on WIN SOURCE:

 [View GH1922LUA on WIN SOURCE](#)

 [GoChip Information](#)

Optimize Your Supply Chain with WIN SOURCE Solutions

-  Global Sourcing Solution
-  Obsolete Management
-  Cost Control Management
-  Shortage Management
-  Alternative Solution
-  Excess Inventory Management