



THE DATASHEET OF BFR380F



BFR380F — Microwave low noise silicon bipolar RF transistor

Description

- The transistor is suitable for operation with a collector current of 30 to 40mA and a voltage range of 3 to 5V; It can amplify signals for oscillator circuits operating at frequencies up to 3.8 GHz; At 1.8 GHz, the noise is approximately 1.1 dB;
-
- Low leakage current, small junction capacitance, wide dynamic range, and ideal current linearity; Utilizing lead-free (Pb-free) surface-mount SOT323 packaging compliant with RoHS regulations;
- Mainly used in television tuners, satellite TV receivers, CATV video amplifiers, analog-digital cordless phones, radar motion sensors, wireless remote data transmission, wireless communications, RFID passive RFID systems, optical fiber amplifiers, etc.
- Ideal for signal amplification in VHF/UHF amplifiers, oscillators, mixers, detectors, and high-frequency microwave signal transmission and reception circuits;
- Package type: SOT323, Marking: FCs.

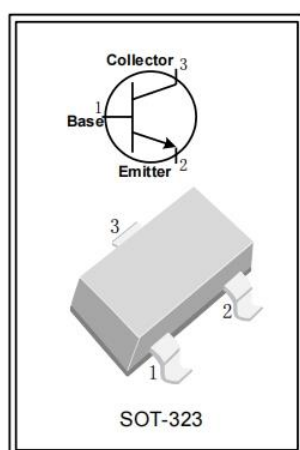

Maximum Ratings (T_{amb}=25°C)

Parameter	Symbol	Value	Unit
collector-base breakdown voltage	BV _{CBO}	15	V
collector-emitter breakdown voltage	BV _{CEO}	6	V
emitter-base breakdown voltage	BV _{EBO}	2	V
collector current	I _C	80	mA
power dissipation	P _T	380	mW
maximum junction temperature	T _J	150	°C
storage temperature	T _{STG}	-65~+150	°C

Electrical characteristics ($T_{amb}=25^{\circ}C$) :

Parameter	Symb ol	Conditions	Min.	Typ.	Max.	Unit
collector emitter breakdown voltage	BV_{CEO}	$I_C=1mA, I_B=0$	6	9	-	V
collector emitter cutoff current	I_{CES}	$V_{CE}=4V, V_{BE}=0$	-	1	30	nA
collector base cut-off current	I_{CBO}	$V_{CB}=6V, I_E=0$	-	-	100	nA
emitter base cutoff current	I_{EBO}	$V_{EB}=6V, I_C=0$	-	-	-	μA
DC current amplification factor	h_{FE}	$V_{CE}=3V, I_C=40mA$	80	100	200	-
characteristic frequency	f_T	$V_{CE}=3V, I_C=15mA, f=1GHz$	11	14	-	GHz
feedback capacitor	C_{re}	$I_C=i_C=0, V_{CB}=5V, f=1MHz$	-	0.2	-	pF
collector capacitance	C_C	$I_E=i_e=0, V_{CB}=5V, f=1MHz$	-	0.47	0.7	pF
emitter capacitance	C_e	$I_C=i_C=0, V_{EB}=0.5V, f=1MHz$	-	1	-	pF
insertion power gain	$ S_{21} ^2$	$V_{CE}=3V, I_C=40mA, f=1.8GHz$	-	11	-	dB
		$V_{CE}=3V, I_C=40mA, f=3.0GHz$	-	6.5	-	dB
noise figure	NF	$V_{CE}=3V, I_C=8mA, f=1.8GHz$	-	1.1	-	dB
maximum unilateral power gain	G_{UM}	$V_{CE}=3V, I_C=40mA, f=1.8GHz$	-	13.5	-	dB
		$V_{CE}=3V, I_C=40mA, f=3.0GHz$	-	9	-	dB
output third-order intercept point gain	IP3	$V_{CE}=3V, I_C=40mA, Z_S=Z_L=50\Omega, f=1.8GHz$	-	29	-	dBm

$$G_{UM} = 10 \log \frac{|S_{21}|^2}{(1 - S_{11})^2 (1 - S_{22})^2} dB$$

Typical characteristic curve

$T_A=25^\circ\text{C}$, unless otherwise specified

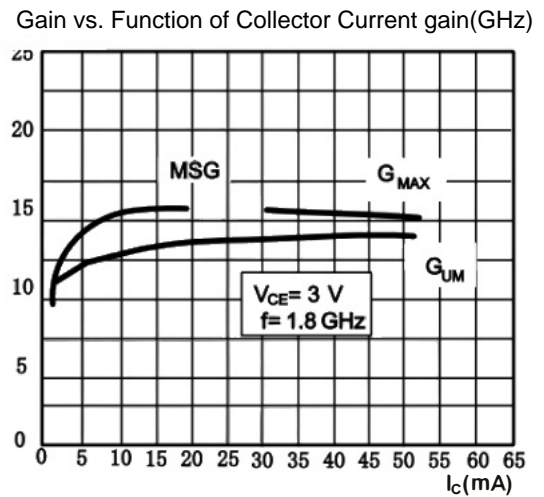
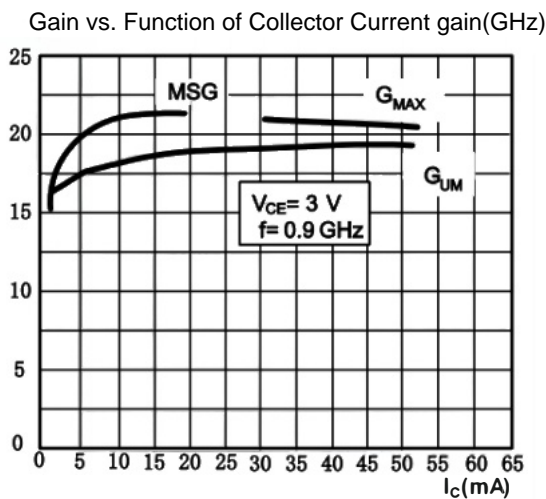
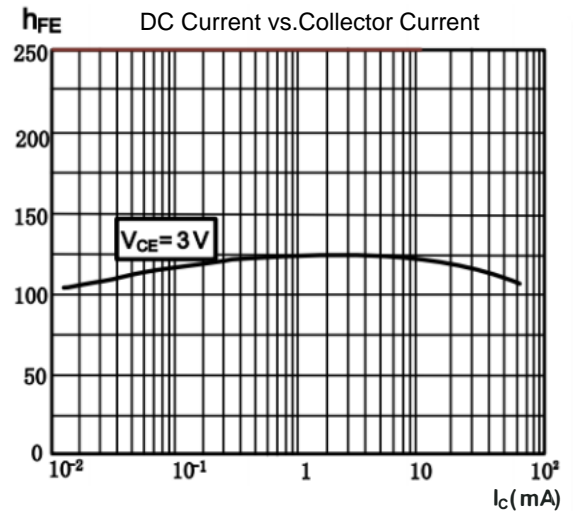
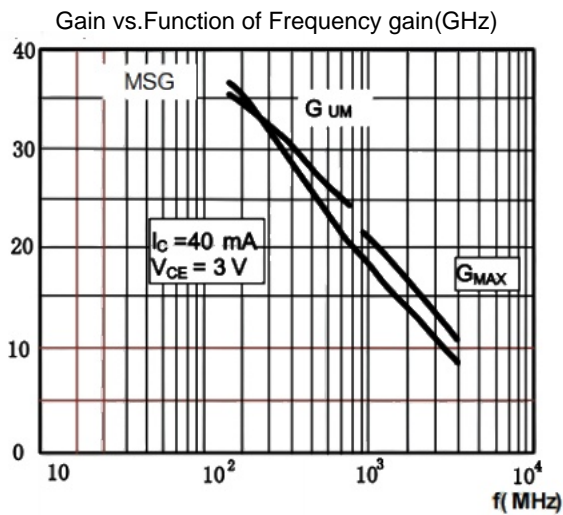
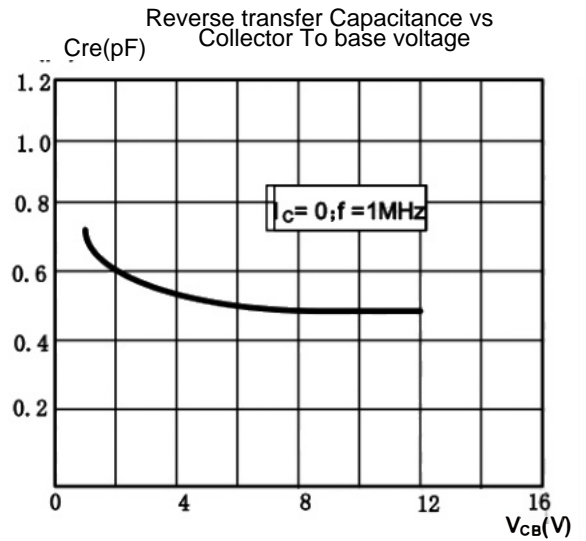
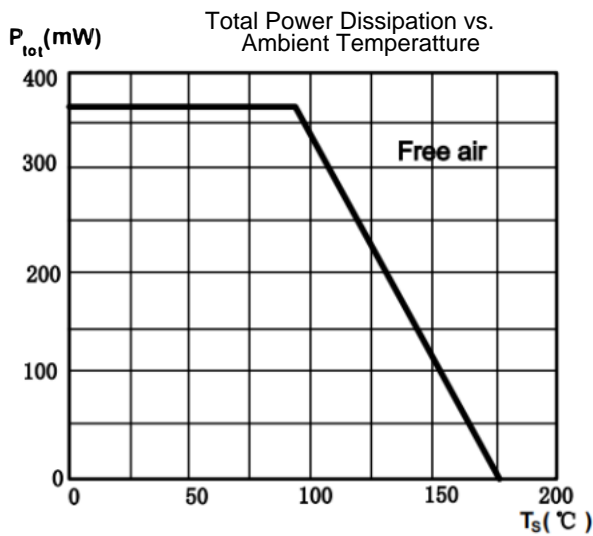

Gain vs. Function of Collector Current gain(GHz)

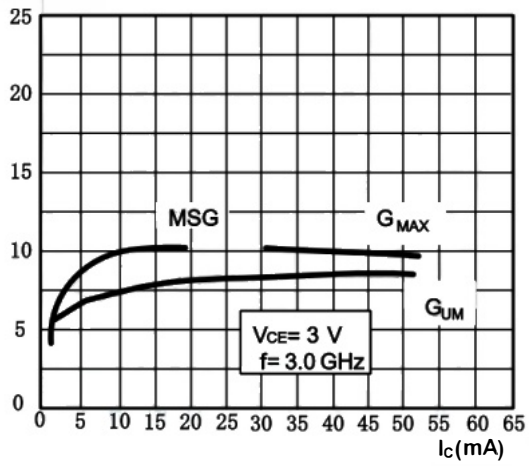

Noise Figure vs. Collector Current

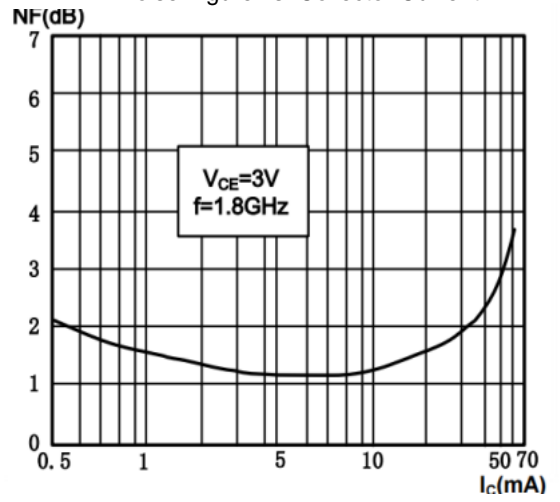

Looking for pricing, stock, or lifecycle information?

Click below to explore more details on WIN SOURCE:

- [View BFR380F on WIN SOURCE](#)
- [ShenZhen SikorMicro Semicon Co. Ltd Information](#)

Optimize Your Supply Chain with WIN SOURCE Solutions

- ✓ Global Sourcing Solution
- ✓ Obsolete Management
- ✓ Cost Control Management
- ✓ Shortage Management
- ✓ Alternative Solution
- ✓ Excess Inventory Management