



THE DATASHEET OF LM317M



DESCRIPTION

The **LM317** is an adjustable 3-terminal positive voltage regulator, designed to supply 1.4A of output current with voltage adjustable from 1.2V ~ 37V.

FEATURES

- * Output voltage adjustable from 1.2V ~ 37V
- * Output current in excess of 1.4A
- * Internal thermal overload protection
- * Internal short circuit current limiting
- * Output transistor safe area compensation

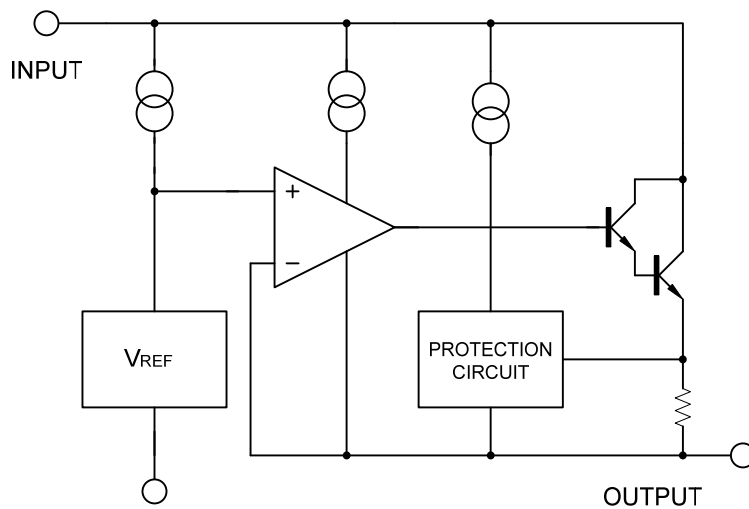
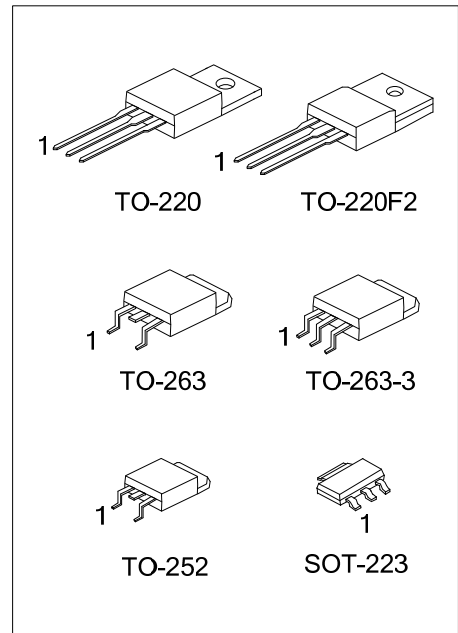

Order Information

Type	Package
LM317	TO-220
LM317F	TO-220F2
LM317C	TO-263
LM317K	TO-263-3
LM317M	TO-252
LM317G	SOT-223

■ ABSOLUTE MAXIMUM RATINGS

PARAMETER	SYMBOL	RATINGS	UNIT
Input-Output Voltage Differential	$V_{IN}-V_{OUT}$	40	V
Power Dissipation	P_D	Internally limited	
Junction Temperature	T_J	+125	°C
Operating Temperature	T_{OPR}	-40 ~ +85	°C
Storage Temperature	T_{STG}	-65 ~ +150	°C

Note: Absolute maximum ratings are those values beyond which the device could be permanently damaged.

Absolute maximum ratings are stress ratings only and functional device operation is not implied.

■ THERMAL DATA

PARAMETER	SYMBOL	RATINGS	UNIT
Junction to Ambient	SOT-223	140	°C/W
	TO-220/TO-220F2	50	°C/W
	TO-252	103	°C/W
	TO-263/TO-263-3	62.5	°C/W
Junction to Case	SOT-223	23.5	°C/W
	TO-220/TO-263	5	°C/W
	TO-263-3	8	°C/W
	TO-220F2	12	°C/W

■ ELECTRICAL CHARACTERISTICS

($V_{IN}-V_{OUT}=5V$, $I_{OUT}=0.5A$, $P_{MAX}=20W$, $T_A=25^{\circ}C$, unless otherwise specified.)

PARAMETER	SYMBOL	TEST CONDITIONS	MIN	TYP	MAX	UNIT	
Line Regulation	$\Delta V_{OUT}/V_{OUT}$	$3V \leq V_{IN}-V_{OUT} \leq 40V$, $I_{OUT}=100mA$		0.01	0.04	%/V	
Load Regulation	ΔV_{OUT}	$10mA \leq I_{OUT} \leq 1.5A$	$V_{OUT} \leq 5V$	5	25	mV	
			$V_{OUT} \geq 5V$	0.1	0.5	%	
Adjustable Pin Current	I_{ADJ}			50	100	μA	
Adjustable Pin Current Change	ΔI_{ADJ}	$3V \leq V_{IN}-V_{OUT} \leq 40V$, $10mA \leq I_{OUT} \leq 500mA$		0.2	5	μA	
Reference Voltage	V_{REF}	$3V \leq V_{IN}-V_{OUT} \leq 40V$, $10mA \leq I_{OUT} \leq 1.5A$, $P_D < P_{MAX}$	1.20	1.25	1.30	V	
Temperature Stability		$T_{MIN} \leq T_J \leq T_{MAX}$		0.7		%/V _{OUT}	
Minimum Load Current for Regulation	$I_{L(MIN)}$	$V_{IN}-V_{OUT}=40V$			4.5	mA	
Maximum Output Current	$I_{O(MAX)}$	$V_{IN}-V_{OUT}=40V$, $P_D \leq P_{MAX}$	0.3	0.4		A	
		$V_{IN}-V_{OUT}=15V$, $P_D < P_{MAX}$	1.5	2.2		A	
RMS Noise vs. % of V_{OUT}	eN	$10Hz \leq f \leq 10KHz$		0.003		%/V _{OUT}	
Ripple Rejection	RR	$V_{OUT}=10V$, $f=120Hz$	$C_{ADJ}=0$		65		dB
			$C_{ADJ}=10\mu F$	66	80		dB

■ APPLICATION CIRCUITS

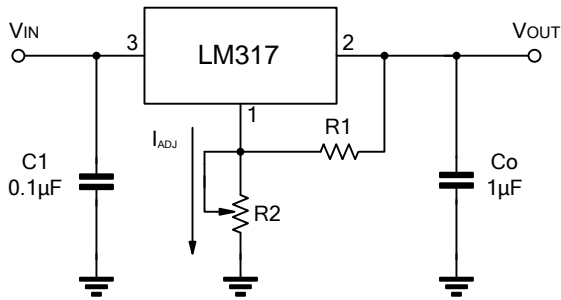

$$V_{OUT} = 1.25V \times (1 + R2/R1) + I_{ADJ} \times R2$$

C1 is required when regulator is located an appreciated distance from power supply. Co is needed to improve transient response.

Fig.1 Programmable voltage regulator

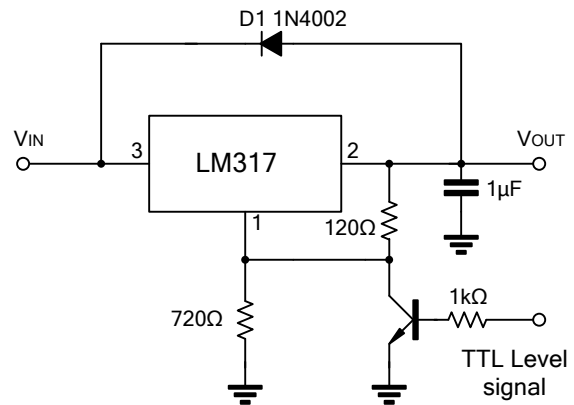

Fig.2 Regulator with On-off control

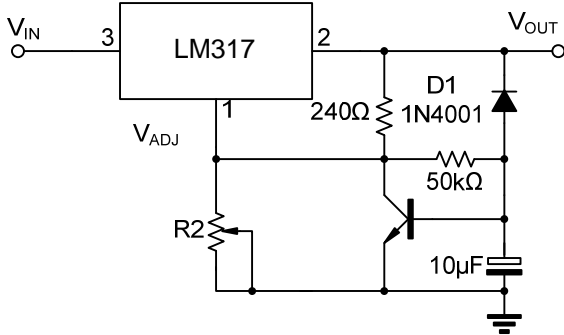
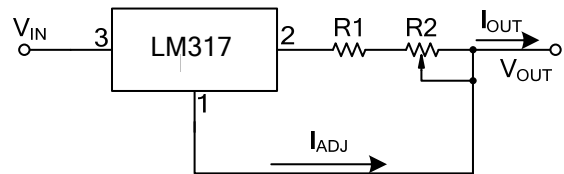

Fig.3 Soft Start Application



$$I_{O(MAX)} = \left(\frac{V_{REF}}{R1} \right) + I_{ADJ} = \frac{1.25V}{R1}$$

$$I_{O(MIN)} = \left(\frac{V_{REF}}{R1+R2} \right) + I_{ADJ} = \frac{1.25V}{R1+R2}$$

Fig.4 Constant Current Application

■ TYPICAL CHARACTERISTICS

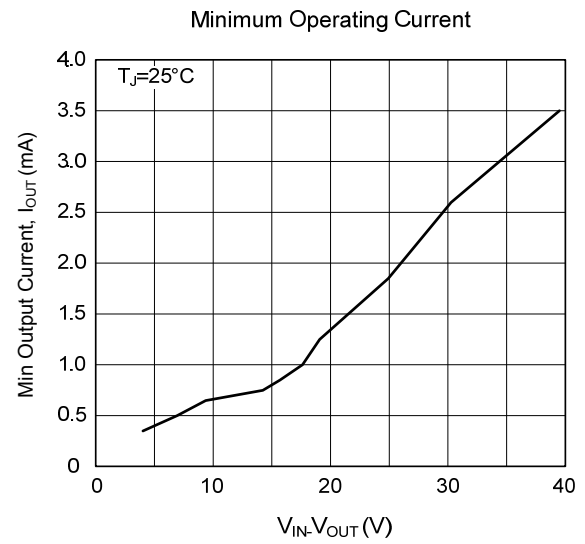
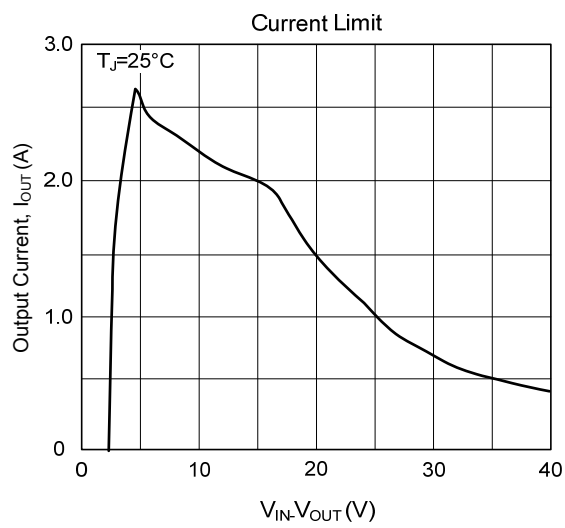
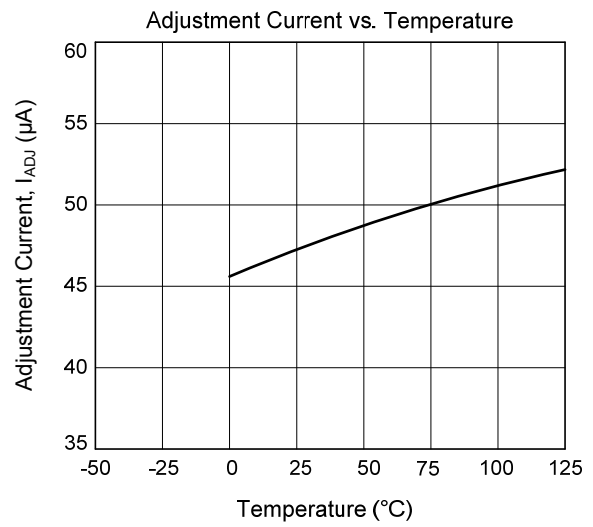
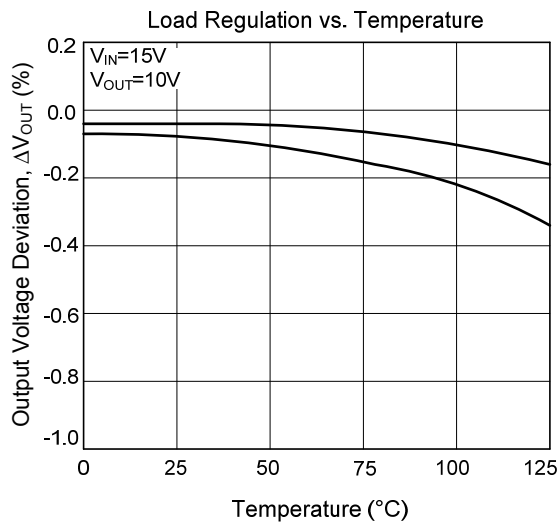

Looking for pricing, stock, or lifecycle information?

Click below to explore more details on WIN SOURCE:

- [View LM317M on WIN SOURCE](#)
- [ShenZhen SikorMicro Semicon Co. Ltd Information](#)

Optimize Your Supply Chain with WIN SOURCE Solutions

- ✓ Global Sourcing Solution
- ✓ Obsolete Management
- ✓ Cost Control Management
- ✓ Shortage Management
- ✓ Alternative Solution
- ✓ Excess Inventory Management