



**THE DATASHEET OF  
EH2600TS-16.000M**



ECN/PCN No.: **4458**

For Manufacturer		
<b>Product Description:</b> Ceramic SMD Crystal Oscillator	<b>Abracon Part Number / Part Series:</b> EH26 Series	<input type="checkbox"/> Documentation only <input checked="" type="checkbox"/> Series <input checked="" type="checkbox"/> ECN <input type="checkbox"/> Part Number <input checked="" type="checkbox"/> EOL
<b>Affected Revision:</b> Rev. G 06/06/2012	<b>New Revision:</b> EOL	<b>Application:</b> <input type="checkbox"/> Safety <input checked="" type="checkbox"/> Non-Safety
<b>Prior to Change:</b> ACTIVE		
<b>After Change:</b> EOL		
<b>Cause/Reason for Change:</b> Discontinuation of manufacturing capability		
Change Plan		
<b>Effective Date:</b> 11/15/2022	<b>Additional Remarks:</b> N/A	
<b>Change Declaration:</b> N/A		
<b>Issued Date:</b> 11/15/22	<b>Issued By:</b> <i>Conor Healey</i>	<b>Issued Department:</b> Engineering
<b>Approval:</b> <i>Thomas Culhane</i> Engineering Director	<b>Approval:</b> <i>Reuben Quintanilla</i> Quality Director	<b>Approval:</b> <i>Ying Huang</i> Purchasing Director
For Abracon EOL only		
<b>Last Time Buy (if applicable):</b> 02-15-2023 <small>Based upon material availability, contact Abracon for details</small>	<b>Alternate Part Number / Part Series:</b> ASVDV, ASV	
<b>Additional Approval:</b>	<b>Additional Approval:</b>	<b>Additional Approval:</b>
Customer Approval (If Applicable)		
<b>Qualification Status:</b> <input type="checkbox"/> Approved <input type="checkbox"/> Not accepted <i>Note: It is considered approved if there is no feedback from the customer 1 month after ECN/PCN is released.</i>		
<b>Customer Part Number:</b>	<b>Customer Project:</b>	
<b>Company Name:</b>	<b>Company Representative:</b>	<b>Representative Signature:</b>
<b>Customer Remarks:</b>		

## REGULATORY COMPLIANCE

 <p><b>Lead Free</b> COMPLIANT</p>	 <p><b>EU RoHS</b> 2011/65 + 2015/863 COMPLIANT</p>	 <p><b>China RoHS</b> COMPLIANT</p>	 <p><b>REACH</b> SVHC COMPLIANT</p>	 <p><b>DRC</b> CONFLICT FREE</p>
--	--	--	--	---

## ITEM DESCRIPTION

Quartz Crystal Clock Oscillators XO (SPXO) LVCMOS (CMOS) 3.3Vdc 4 Pad 5.0mm x 7.0mm Ceramic Surface Mount (SMD)

## ELECTRICAL SPECIFICATIONS

<b>Nominal Frequency</b>	1MHz to 155.52MHz
<b>Frequency Tolerance/Stability</b>	Inclusive of all conditions: Calibration Tolerance at 25°C, Frequency Stability over the Operating Temperature Range, Supply Voltage Change, Output Load Change, First Year Aging at 25°C, Shock, and Vibration ±100ppm Maximum ±20ppm Maximum ±25ppm Maximum ±50ppm Maximum
<b>Aging at 25°C</b>	±5ppm/year Maximum
<b>Operating Temperature Range</b>	0°C to +70°C -40°C to +85°C
<b>Supply Voltage</b>	3.3Vdc ±10%
<b>Input Current</b>	No Load 35mA Maximum
<b>Output Voltage Logic High (V<sub>OH</sub>)</b>	I <sub>OH</sub> = -8mA 2.7Vdc Minimum
<b>Output Voltage Logic Low (V<sub>OL</sub>)</b>	I <sub>OL</sub> = +8mA 0.5Vdc Maximum
<b>Rise/Fall Time</b>	Measured at 20% to 80% of waveform 6nSec Maximum over Nominal Frequency of 1MHz to 70MHz 4nSec Maximum over Nominal Frequency of 70.000001MHz to 155.52MHz
<b>Duty Cycle</b>	Measured at 50% of waveform 50 ±10(%) 50 ±5(%)
<b>Load Drive Capability</b>	30pF Maximum over Nominal Frequency of 1MHz to 70MHz 15pF Maximum over Nominal Frequency of 70.000001MHz to 155.52MHz
<b>Output Logic Type</b>	CMOS
<b>Pin 1 Connection</b>	Tri-State (High Impedance)
<b>Tri-State Input Voltage (V<sub>IH</sub> and V<sub>IL</sub>)</b>	70% of V <sub>DD</sub> Minimum to enable output, 20% of V <sub>DD</sub> Maximum to disable output, No Connect to enable output.
<b>Absolute Clock Jitter</b>	±250pSec Maximum, ±100pSec Typical
<b>One Sigma Clock Period Jitter</b>	±50pSec Maximum, ±40pSec Typical
<b>Start Up Time</b>	10mSec Maximum
<b>Storage Temperature Range</b>	-55°C to +125°C

## PART NUMBERING GUIDE

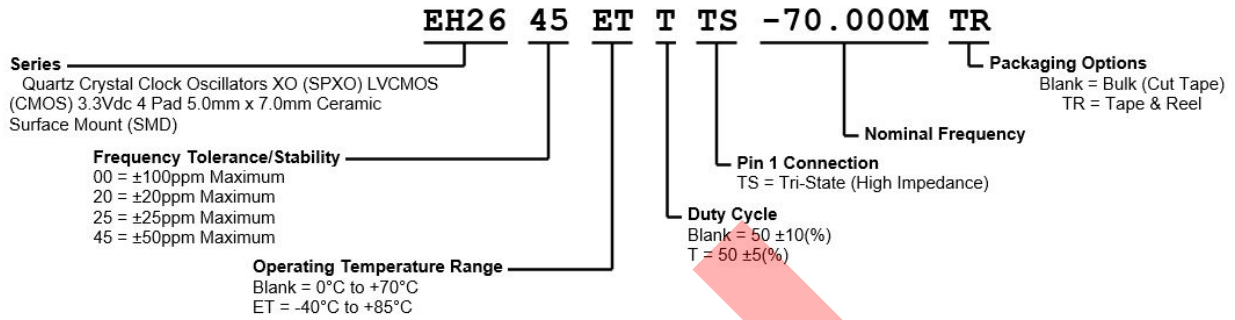

**MECHANICAL DIMENSIONS**

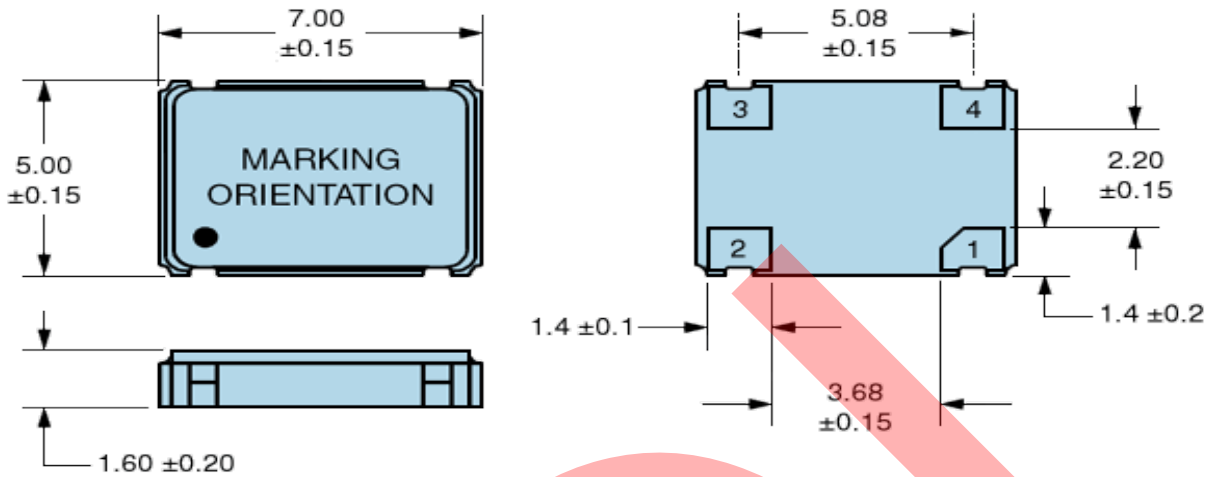

**SUGGESTED SOLDER PAD LAYOUT**

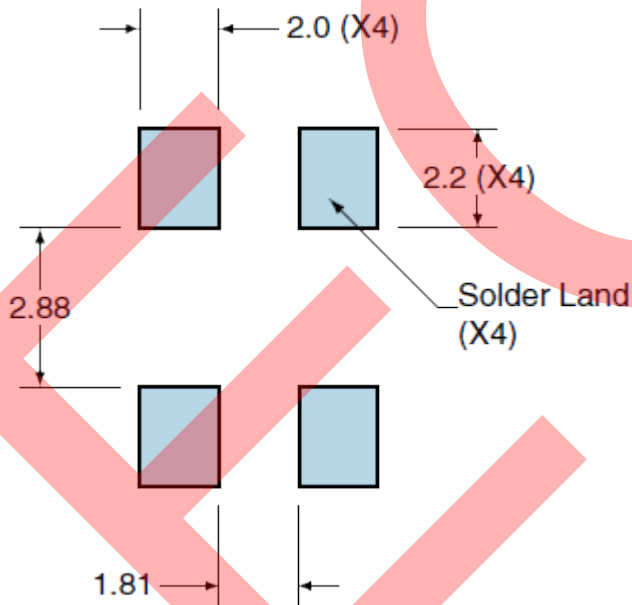

PIN	CONNECTION
1	Tri-State
2	Ground
3	Output
4	Supply Voltage

All Tolerances are ±0.1

**All Dimensions in Millimeters**

OUTPUT WAVEFORM & TIMING DIAGRAM

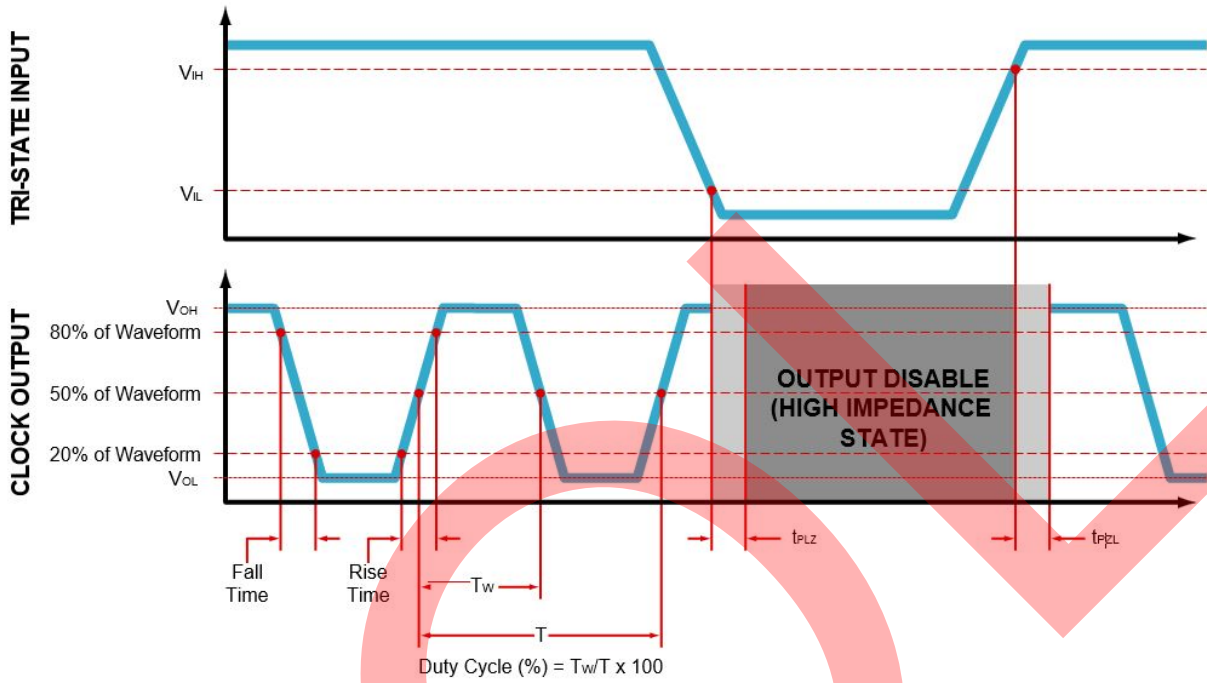

## TEST CIRCUIT FOR CMOS OUTPUT

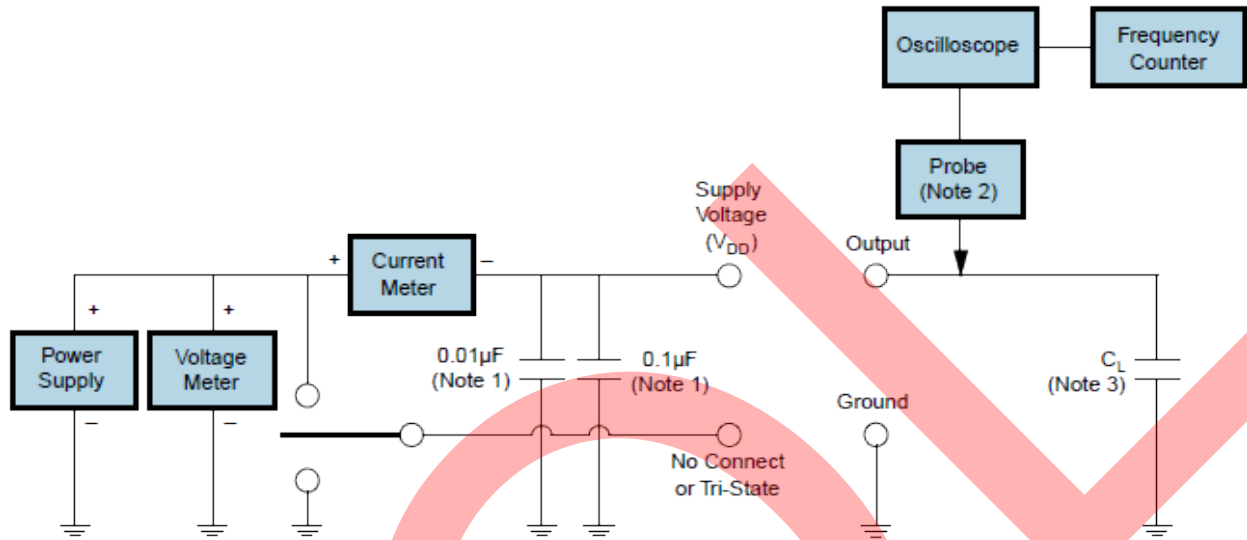

**Note 1:** An external 0.1µF low frequency tantalum bypass capacitor in parallel with a 0.01µF high frequency ceramic bypass Capacitor close to the package ground and  $V_{DD}$  pin is required.

**Note 2:** A low capacitance (<12pF), 10X attenuation factor, high impedance (>10Mohms), and high bandwidth (>300MHz) passive Probe is recommended.

**Note 3:** Capacitance value  $C_L$  includes sum of all probe and fixture capacitance.

**TAPE & REEL DIMENSIONS**

Quantity per Reel: 1,000 Units

All Dimensions in Millimeters

Compliant to EIA-481

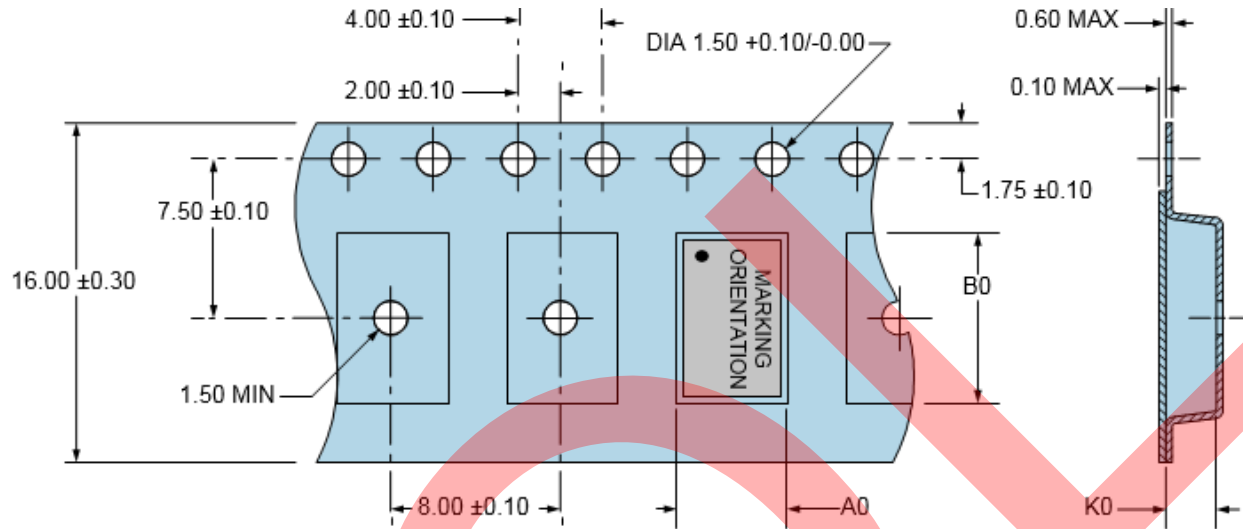

**Direction of Unreeling**

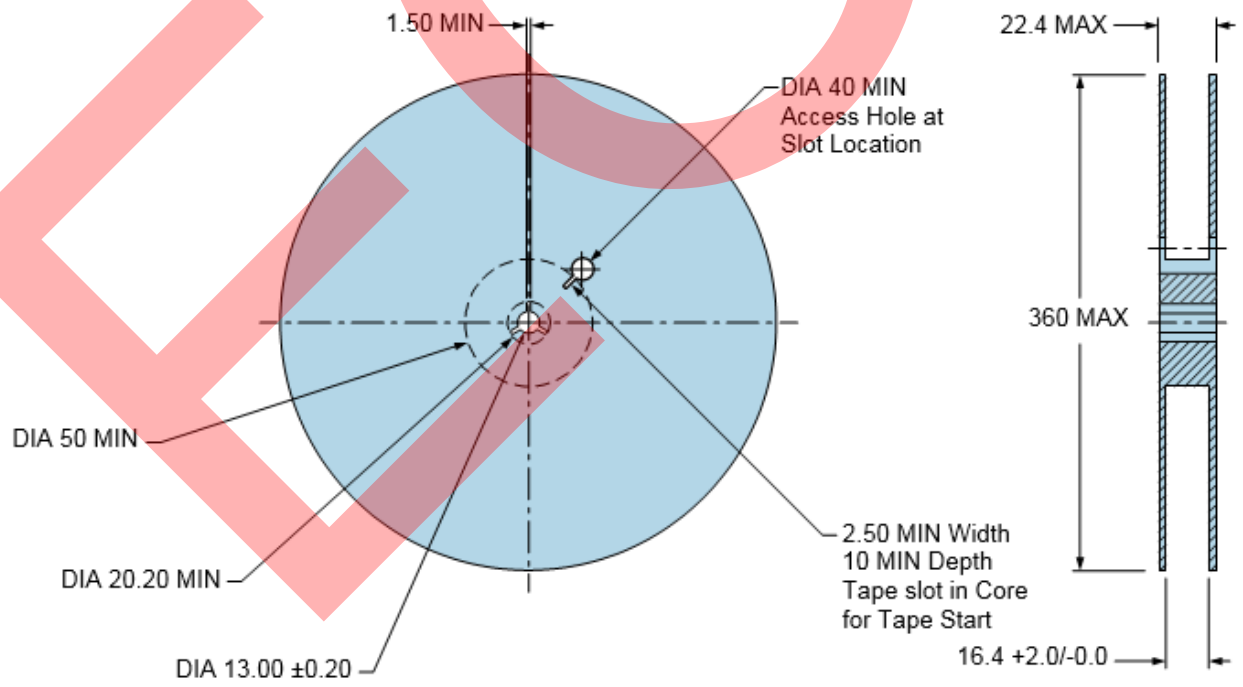

**RECOMMENDED SOLDER REFLOW METHOD**

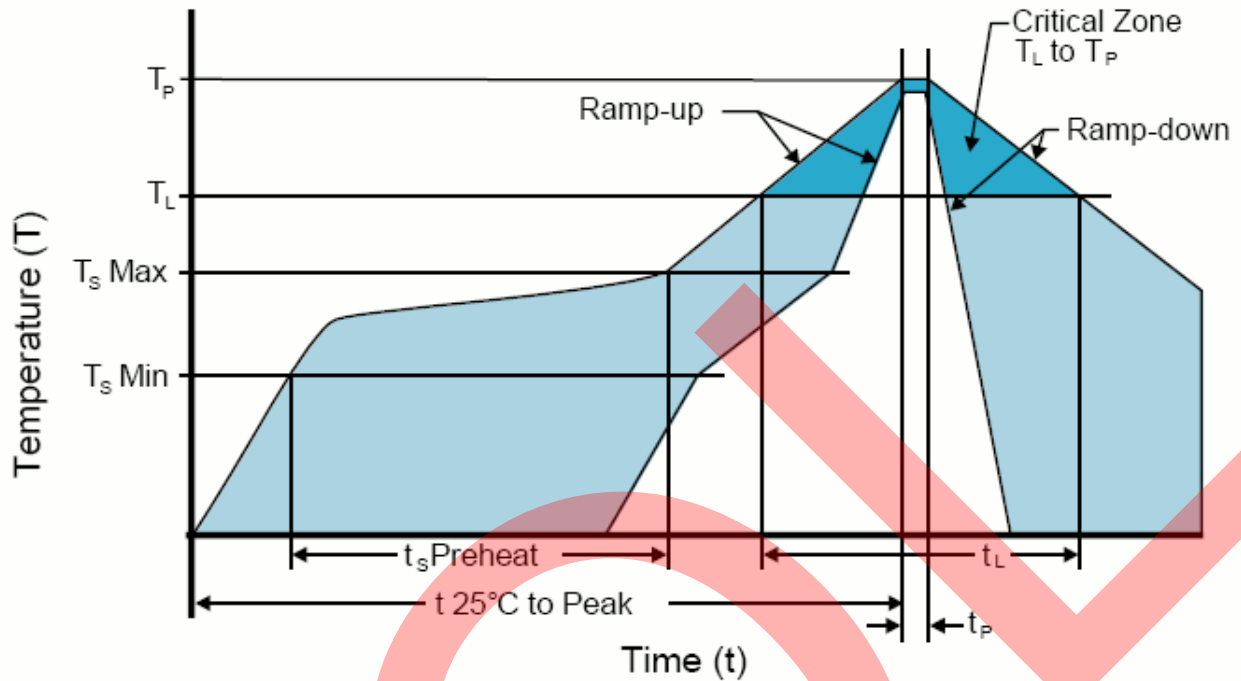

**HIGH TEMPERATURE INFRARED/CONVECTION**

<b>TS MAX to TL (Ramp-up Rate)</b>	3°C/Second Maximum
<b>Preheat</b>	
- Temperature Minimum (T <sub>S</sub> MIN)	150°C
- Temperature Typical (T <sub>S</sub> TYP)	175°C
- Temperature Maximum(T <sub>S</sub> MAX)	200°C
- Time (t <sub>s</sub> MIN)	60 - 180 Seconds
<b>Ramp-up Rate (TL to TP)</b>	3°C/Second Maximum
<b>Time Maintained Above:</b>	
- Temperature (T <sub>L</sub> )	217°C
- Time (t <sub>L</sub> )	60 - 150 Seconds
<b>Peak Temperature (TP)</b>	260°C Maximum for 10 Seconds Maximum
<b>Target Peak Temperature(TP Target)</b>	250°C +0/-5°C
<b>Time within 5°C of actual peak (tp)</b>	20 - 40 Seconds
<b>Ramp-down Rate</b>	6°C/Second Maximum
<b>Time 25°C to Peak Temperature (t)</b>	8 Minutes Maximum
<b>Moisture Sensitivity Level</b>	Level 1
<b>Additional Notes</b>	Temperatures shown are applied to body of device.

**High Temperature Manual Soldering**

260°C Maximum for 5 Seconds Maximum, 2 times Maximum. (Temperatures shown are applied to body of device.)

**RECOMMENDED SOLDER REFLOW METHOD**

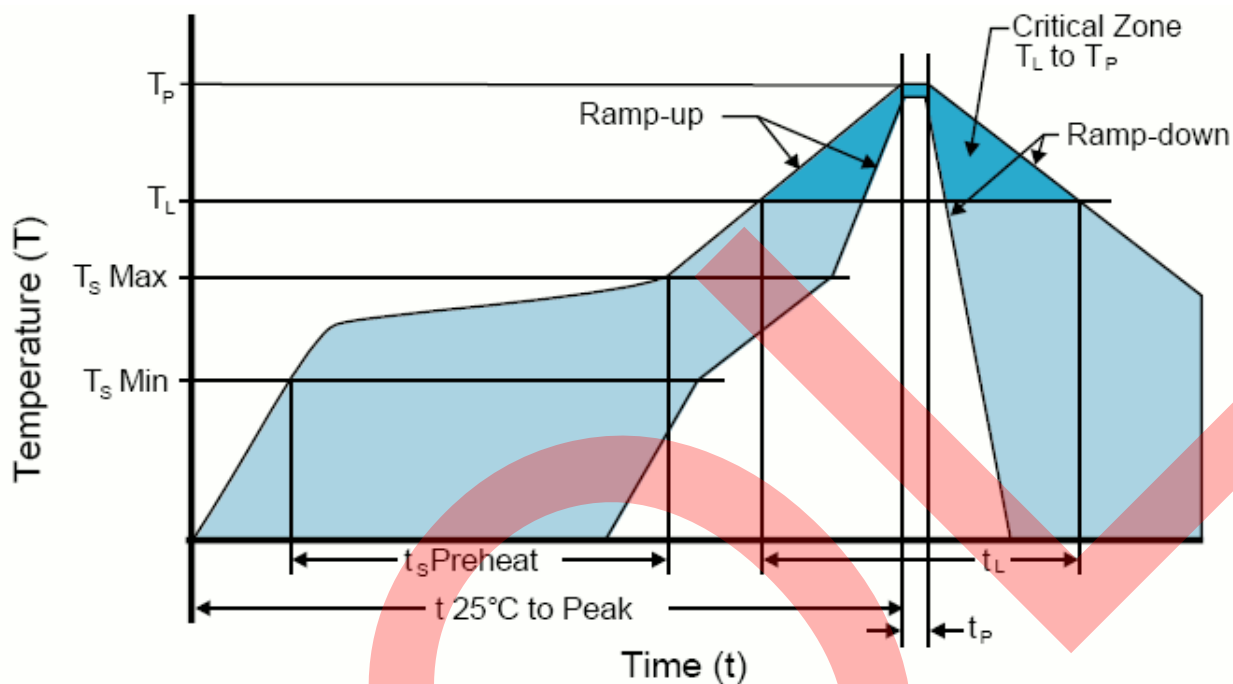

**LOW TEMPERATURE INFRARED/CONVECTION 240°C**

TS MAX to TL (Ramp-up Rate)	5°C/Second Maximum
<b>Preheat</b>	
- Temperature Minimum ( $T_s \text{ MIN}$ )	N/A
- Temperature Typical ( $T_s \text{ TYP}$ )	150°C
- Temperature Maximum ( $T_s \text{ MAX}$ )	N/A
- Time ( $t_s \text{ MIN}$ )	60 - 120 Seconds
<b>Ramp-up Rate (TL to TP)</b>	5°C/Second Maximum
<b>Time Maintained Above:</b>	
- Temperature ( $T_L$ )	150°C
- Time ( $t_L$ )	200Seconds Maximum
<b>Peak Temperature (TP)</b>	240°C
<b>Target Peak Temperature (TP Target)</b>	240°C Maximum 2 Times / 230°C Maximum 1Time
<b>Time within 5°C of actual peak (<math>t_P</math>)</b>	10 Seconds Maximum 2 Times / 80 Seconds Maximum 1 Time
<b>Ramp-down Rate</b>	5°C/Second Maximum
<b>Time 25°C to Peak Temperature (t)</b>	N/A
<b>Moisture Sensitivity Level</b>	Level 1
<b>Additional Notes</b>	Temperatures shown are applied to body of device.

**Low Temperature Manual Soldering**

185°C Maximum for 10 Seconds Maximum, 2 times Maximum. (Temperatures shown are applied to body of device.)

## Looking for pricing, stock, or lifecycle information?

Click below to explore more details on WIN SOURCE:

 [View EH2600TS-16.000M on WIN SOURCE](#)

 [Abracon LLC Information](#)

## Optimize Your Supply Chain with WIN SOURCE Solutions

-  Global Sourcing Solution
-  Obsolete Management
-  Cost Control Management
-  Shortage Management
-  Alternative Solution
-  Excess Inventory Management